



**HAL**  
open science

# A Fast MOSFET RF Switch for TRASE MRI at Low Magnetic Field

P.-J Nacher, S Kumaragamage, G. Tastevin, C P Bidinosti

► **To cite this version:**

P.-J Nacher, S Kumaragamage, G. Tastevin, C P Bidinosti. A Fast MOSFET RF Switch for TRASE MRI at Low Magnetic Field. Joint annual meeting ISMRM-ESMRMB 2018, Proc. of the Intl. Soc. Mag. Reson. Med., Jun 2018, Paris, France. pp.1699. hal-02366385

**HAL Id: hal-02366385**

**<https://hal.science/hal-02366385>**

Submitted on 15 Nov 2019

**HAL** is a multi-disciplinary open access archive for the deposit and dissemination of scientific research documents, whether they are published or not. The documents may come from teaching and research institutions in France or abroad, or from public or private research centers.

L'archive ouverte pluridisciplinaire **HAL**, est destinée au dépôt et à la diffusion de documents scientifiques de niveau recherche, publiés ou non, émanant des établissements d'enseignement et de recherche français ou étrangers, des laboratoires publics ou privés.

Copyright

This is the peer reviewed version of the abstract n° 2874 which can be found in final form in:  
Proc. of the Intl. Soc. Mag. Reson. Med. 26 (2018) 1699

## A Fast MOSFET RF Switch for TRASE MRI at Low Magnetic Field

P.-J. Nacher<sup>1</sup>, S. Kumaragamage<sup>2,3</sup>, G. Tastevin<sup>1</sup>, C.P. Bidinosti<sup>2</sup>;

<sup>1</sup> Laboratoire Kastler Brossel, ENS-Université PSL, CNRS, Sorbonne Université, Collège de France, Paris, France <sup>2</sup> Department of Physics, University of Winnipeg, Winnipeg, MB, Canada <sup>3</sup> Rady Faculty of Health Sciences, College of Medicine, University of Manitoba, Winnipeg, MB, Canada

Abstract 2874 Type: Poster

### Synopsis

TRansmit Array Spatial Encoding (TRASE) MRI uses trains of  $B_1$  pulses alternatively produced by distinct transmit coils. Commonly used coil switching involving PIN diodes is too slow for low-field MRI and would introduce wait times between pulses typically as long as each individual pulse (hence, significant diffusion-induced resolution loss in TRASE MRI of gas samples). A MOSFET-based RF switch is described and characterised. Up to 200 kHz, it allows for sub- $\mu$ s switching of RF currents from a single amplifier to several coils with sufficient isolation ratio and no delay between pulses.

### Introduction

TRansmit Array Spatial Encoding (TRASE) is a MRI method using repeated pulses of radiofrequency (RF)  $B_1$  fields from different phase-gradient transmit coils instead of the standard imaging gradients of  $B_0$  to manage spatial encoding.<sup>1,2</sup> An evaluation of the benefits and limitations of TRASE MRI at low field (a few mT) is under way using hyperpolarised gas samples.<sup>3,4</sup> Fast switching between two or more transmit coils with sufficient isolation and negligible wait time between pulses is required to jointly reduce the total RF encoding time and the RF peak power. PIN diodes are often used for coil switching,<sup>2</sup> but bias control with RF isolation involves response times (several RF periods) which are too slow for the targeted low-frequency application.

### Methods

Switching times (delays and jitter) have been inferred from datasheet or measured for different mechanical switches (MEMS, reed or standard relays). Bidirectional MOSFET switch prototypes, with floating and optically isolated gate control, have been designed and wired (Figs. 1 and 2). Electrical tests have been performed using different RF power amplifiers (a 250-W-peak, BT00250-Alpha A model, Tomco Technologies, and a 100-W-CW in-house linear amplifier), different loads (a 50- $\Omega$  resistive load or tuned and untuned transmit coils), and different frequencies (in the range DC – 200 kHz). An Apollo Tecmag console (low-frequency LF1 model), allowing for 100 ns time resolution of sequence events, was used to manage RF pulses and TTL signals to control switches. RF currents were recorded using a 4-channels digital oscilloscope by monitoring the voltage drop across a 1- $\Omega$  resistor inserted on the ground return line at the output of the RF amplifier.

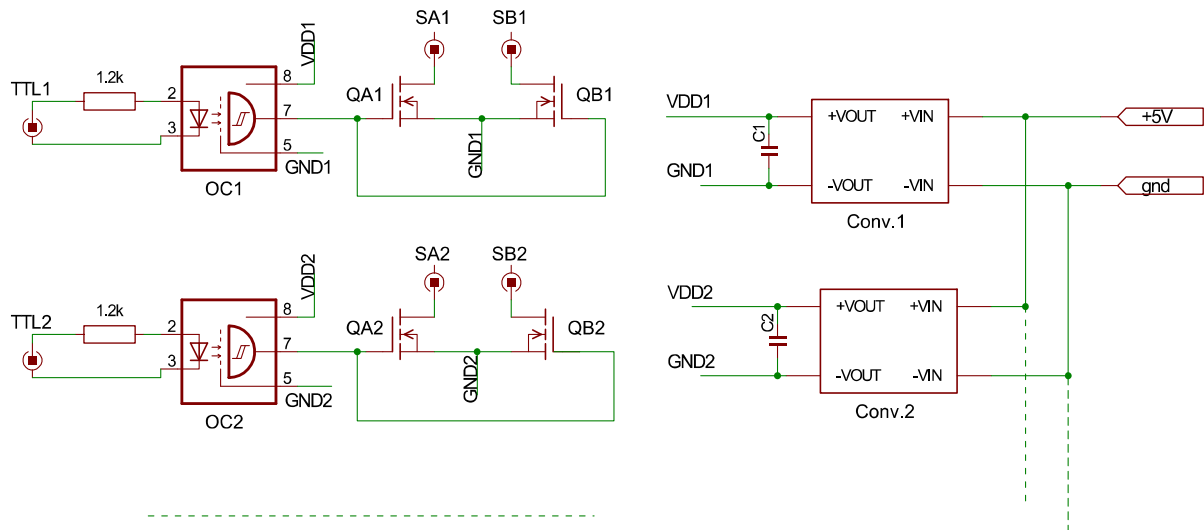

Figure 1: Schematic drawing of the MOSFET switches used for low-frequency TRASE MRI. Two of the three identical channels are displayed. On the right-hand side, independent DC-DC converters (Conv.) are used as floating 12-V power supplies of the gate control circuits. On the left-hand side, optocouplers (OC) are used to isolate the TTL control inputs from the power MOSFETS QA and QB which act as bipolar switches between terminals SA and SB.

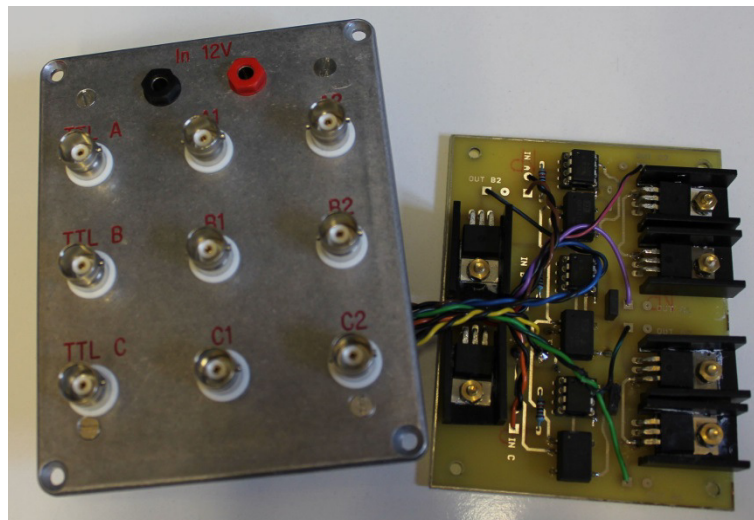
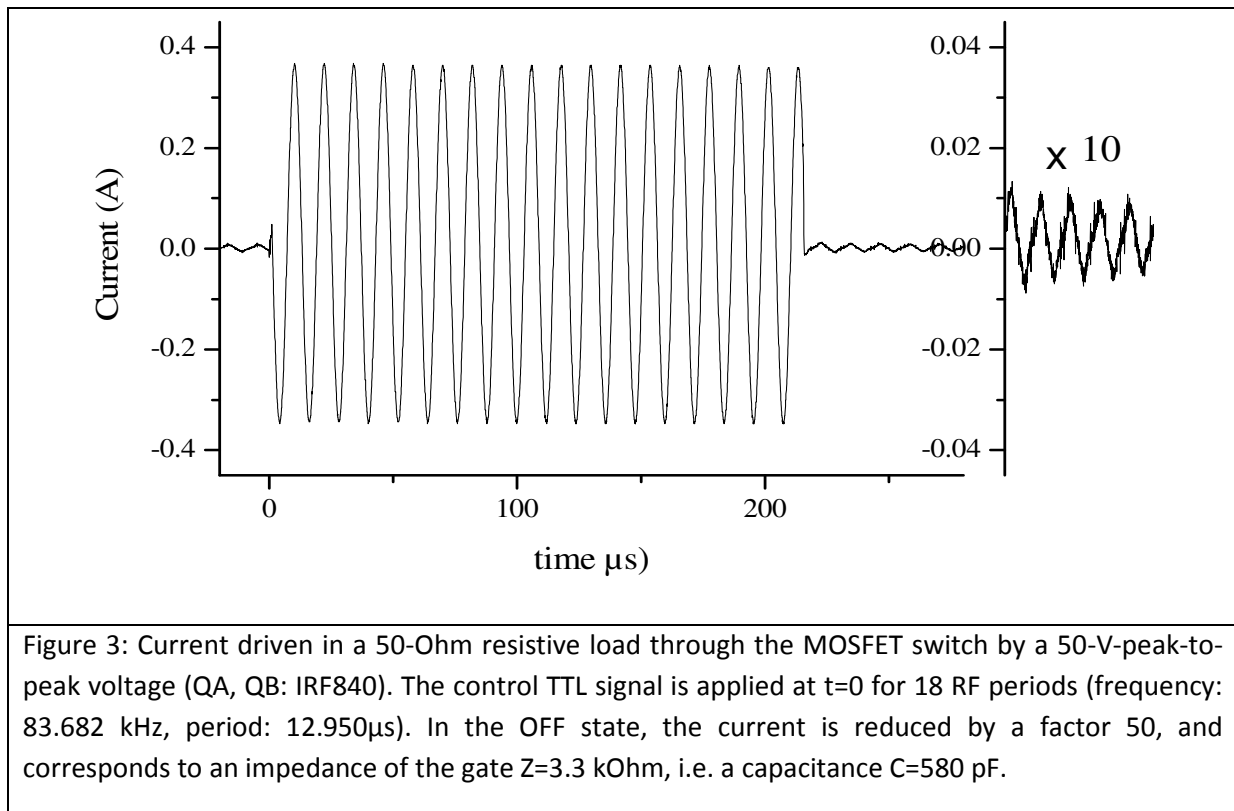

Figure 2: Photograph of a prototype MOSFET switch with 3 independent channels (see Fig. 1). The tested components are: IK0512SA or ISE1212A (Conv.), HCPL2201 (OC), and IRF840 or IRF730 (QA, QB).

## Results

Switching times of mechanical relays range from 10  $\mu$ s (for MR-compatible MEMS [5]) to several ms. Fast reed relays are widely available and economical, can be operated in the vicinity of low-field MR systems, and have close/release times of 0.15/0.1 ms for typical carry currents of 1 A, while miniature relays with 4-A carry currents have typical switching times of 1 ms. The MOSFET switch of Fig. 2 (with IRF 840, up to 32 A) has switching times below 1  $\mu$ s. It has a low ON impedance (about 1 Ohm) and a frequency-dependent OFF impedance, consistent with a 500 pF capacitance. This usually provides efficient RF current switching, both on a resistive load (Fig. 3) and on transmit coils (various situations have been evaluated and will be reported). A small RF interference due to the operation of

DC-DC converters is sometimes observed, but a suitable choice of the component eliminates the problem (different components operate at different switching frequencies).



### Discussion/Conclusion

Although magnetically actuated relays provide an excellent switching efficiency and can be operated in low-field MR systems, their slow response times, on the same order as the duration of individual B1 pulses in TRASE sequences (typically 10-20 RF periods around 100 kHz [3]), introduce significant wait times during encoding pulse trains. This may result in prohibitive diffusion-induced resolution loss in gas samples, and acceleration through the use of shorter RF pulses is impractical due to Bloch-Siegert shifts and to the influence of concomitant RF fields [6]. MOSFET-based switches eliminate wait times and RF pulse currents can be switched to different transmit coils with sufficient isolation ratio and no delay between pulses. A choice of the MOSFET components can be made to achieve a suitable compromise between reducing the OFF-state capacitance and managing the required RF voltage and current.

### References

- [1] JC Sharp et al., *Magn Reson Med* 63:151 (2010); *NMR Biomed*, 26: 1602 (2013).
- [2] Q Deng et al., *Magn Reson Imaging* 31:891 (2013).
- [3] PJ Nacher et al., *Proc ESMRMB15, Magn. Reson. Mater. Phy.* 28 Suppl. 1 (2015) p. S64.
- [4] S Kumaragamage et al., *Proc ESMRMB16, Magn. Reson. Mater. Phy.* 29 Suppl. 1 (2015) p. S34.
- [5] D Spence and M Aimi, *Proc Intl Soc Mag Reson Med.* (2015) 23:704.
- [6] CP Bidinosti et al, this conference.