



**HAL**  
open science

# Integration of a thermochemical energy storage system in a Rankine cycle driven by concentrating solar power: Energy and exergy analyses

Ugo Pelay, Lingai Luo, Yilin Fan, Driss Stitou, Cathy Castelain

## ► To cite this version:

Ugo Pelay, Lingai Luo, Yilin Fan, Driss Stitou, Cathy Castelain. Integration of a thermochemical energy storage system in a Rankine cycle driven by concentrating solar power: Energy and exergy analyses. *Energy*, 2019, 167, pp.498-510. 10.1016/j.energy.2018.10.163 . hal-02364774

**HAL Id: hal-02364774**

**<https://hal.science/hal-02364774v1>**

Submitted on 27 Nov 2020

**HAL** is a multi-disciplinary open access archive for the deposit and dissemination of scientific research documents, whether they are published or not. The documents may come from teaching and research institutions in France or abroad, or from public or private research centers.

L'archive ouverte pluridisciplinaire **HAL**, est destinée au dépôt et à la diffusion de documents scientifiques de niveau recherche, publiés ou non, émanant des établissements d'enseignement et de recherche français ou étrangers, des laboratoires publics ou privés.

# Integration of a Thermochemical Energy Storage System in a Rankine Cycle Driven by Concentrating Solar Power: Energy and Exergy Analyses

Ugo PELAY<sup>a</sup>, Lingai LUO<sup>a,\*</sup>, Yilin FAN<sup>a</sup>, Driss STITOU<sup>b</sup>, Cathy CASTELAIN<sup>a</sup>

<sup>a</sup> *Laboratoire de Thermique et Energie de Nantes (LTEN), CNRS UMR 6607, Université de Nantes, La Chantrerie, Rue Christian Pauc, BP 50609, 44306 Nantes Cedex 03, France*

<sup>b</sup> *Laboratoire PROcédés, Matériaux et Energie Solaire (PROMES), CNRS UPR 8521, Tecnosud, Rambla de la thermodynamique, 66100 Perpignan, France*

---

## Abstract:

This paper proposes and investigates novel concepts on the integration of a thermochemical energy storage (TCS) system in a concentrating solar power (CSP) plant. The TCS material used is calcium oxide reacting with water and the power cycle studied is a Rankine cycle driven by CSP. Firstly, three integration concepts on the coupling of the TCS system with the Rankine cycle are proposed, including the thermal integration concept, the mass integration concept and the double turbine concept. Then, an energy analysis is performed to determine and compare the theoretical overall energy efficiency of the proposed concepts. After that, an exergy analysis is also carried out for the selected integration concepts so as to evaluate and compare the overall exergy efficiency of the installation with TCS integration.

The results show that the turbine integration concept has the highest overall energy efficiency (0.392), followed by the thermal integration concept (0.358) and the mass integration concept (0.349) under ideal conditions with 11 h of charging and 13 h of discharging. The energy storage density using calcium hydroxide as the storage media is estimated to be about 100 kWh<sub>e</sub>·t<sup>-1</sup>. Exergy analysis results also indicate that the turbine integration concept seems to be the best option under the tested conditions.

**Keywords:** Thermal energy storage (TES); Thermochemical; Rankine cycle; Concentrating solar power (CSP); Integration concept; Calcium hydroxide; exergy analysis

---

**Declarations of interest: none**

---

\* Corresponding author. Tel.: +33 240683167; E-mail address: [lingai.luo@univ-nantes.fr](mailto:lingai.luo@univ-nantes.fr)

## 40 I. Introduction

41  
42 The increasing energy demand, the environmental protection issue and the national energy  
43 independence all over the world call for researches aiming at more efficient use of renewable energy  
44 such as solar energy. Among various solar energy technologies, the Concentrating Solar Power (CSP)  
45 plants are expected to play an important role in the energetic scenarios owing to its advantages in  
46 terms of high efficiency, low operating cost and good scale-up potential [Cáceres 2013; Zhang 2013;  
47 Dunham 2014; Balghouthi 2016]. According to IRENA [2016], the CSP deployment would reach  
48 44 GW in the reference scenario (Remap 2030). It is estimated that the CSP would contribute up to  
49 11.3% of the electricity production in the year 2050, with 954 GW of installed capacity [IEA 2014;  
50 del Río 2018].

51  
52 One of the advantages of CSP technology is the possibility of integrating a thermal energy  
53 storage (TES) function, permitting the production of electricity any time when it is the most needed  
54 and valuable, whether during the peak hours, nights, or cloudy intervals [Zhang 2016; Dowling  
55 2017; Alva 2018]. To do this, a TES system at high temperature should be designed and installed  
56 properly between the solar field and a power cycle. Although adding a TES system usually increases  
57 the investment cost of the CSP plant, it improves significantly its adaptability and dispatchability.  
58 CSP plants (existing or under construction) having TES systems at high temperature are  
59 summarized in recent reviews [e.g., Tian 2013; Kuravi 2013; Pelay 2017a; b]. The storage capacity  
60 in terms of discharging time is generally between 3 to 8 hours, and recently up to 15 hours  
61 (Gemasolar, Spain) aiming at round-the-clock electricity production driven by solar energy [Dunn  
62 2012].

63  
64 The most commonly used storage technology is based on the sensible heat storage, in which  
65 the thermal energy is stored/released by raising/decreasing the temperature of a storage material.  
66 This technology is the most mature and deeply investigated, with a wide variety of both liquid (e.g.,  
67 pressurized water, molten salt, mineral oil, etc.) and solid (e.g., sand, rock, cast iron, etc.) materials  
68 being used for CSP applications [Gil 2010; Tiskatine 2017]. Some recent developments are also  
69 reported, such as on the use of industrial wastes or by-products [Ortega-Fernández 2015; Gutierrez  
70 2016], chloride salts [Myers 2016], lithium coupled with molten salts [Cabeza 2015], or solid particles  
71 [Zhang 2017a; Calderón 2018]. However, their limited energy density (usually between 60  
72  $\text{kWh}_{\text{th}}\cdot\text{m}^{-3}$  (200 °C-300 °C) for sand, rock and mineral oil, and 150  $\text{kWh}_{\text{th}}\cdot\text{m}^{-3}$  for cast iron (200 °C-  
73 400 °C) [Fernandes 2012]) increases significantly the size of TES systems. Latent heat storage  
74 materials such as Phase Change Materials (PCMs) are also proposed for CSP applications owing to  
75 their higher storage capacity [Gil 2010; Pitié 2013; Sharma 2015; Zhang 2017b; Chirino 2018]. But  
76 their small thermal conductivity (commonly 0.2 - 0.8  $\text{W}\cdot\text{m}^{-1}\cdot\text{K}^{-1}$ ) usually limits the heat transfer,  
77 resulting in very slow charging and discharging processes [Nithyanandam 2015]. Some new  
78 advances on the effective encapsulation of PCMs [Zhang 2014; Parrado 2015] as well as the  
79 enhancement of thermal conductivity are summarized in recent papers [Xu 2015; Liu 2016; Alva  
80 2018].

82 Besides the sensible and latent heat storage technologies, the thermochemical storage (TCS)  
83 is a promising solution for its highest storage capacity (up to 10 times greater than latent storage  
84 [Pardo 2014a]), wide accessible temperature range and long storage duration at ambient  
85 temperature [Prieto 2016]. This technology is mainly based on reversible chemical reactions (e.g.,  
86 gas-solid) involving absorbing or releasing a large amount of reaction heat:

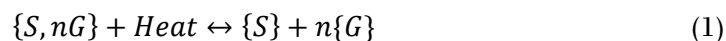

88  
89 The charging stage uses solar energy for the decomposition of  $\{S, nG\}$  associated with the  
90 condensation of the gas while the discharging stage brings the solid and gas into contact for heat  
91 release by the exothermic reaction. TCS material candidates at a medium or high temperature (300–  
92 1000 °C) for CSP application include metallic hydrides, carbonates system, hydroxides system,  
93 redox system, ammonia system and organic system [Kuravi 2013]. Their mains characteristics,  
94 advantages/disadvantages and experimental feedback are reviewed and summarized in [Pelay  
95 2017a].

96  
97 Beyond the testing of new TCS materials [e.g., Deutsch 2017; Valverde 2017;  
98 Bagherisereshki 2018] and proper reactor designs [e.g., Álvarez De Miguel 2013; Schmidt 2017;  
99 Wokon 2017; Pan 2017] and pilot scale testing [Tescari 2017a; b], the TCS system must be coupled  
100 in a proper way with the vapor generator of the power cycle (e.g., Rankine cycle) in a CSP plant.  
101 However, relatively little attention seems to be given to this integration issue. Recently, Cabeza et  
102 al. [2017] proposed a new concept of consecutive TCS reactions (either one cycle or two coupled  
103 cycles) and its implementation in CSP plants, with the purpose of eliminating reversibility problems  
104 and therefore improving the overall efficiency. Ortiz et al. [2017] proposed possible integration  
105 schemes of calcium looping (CaO-CaCO<sub>3</sub>) for power production by direct or indirect means. Their  
106 results showed highest plant efficiencies up to 45–46% using a closed carbon dioxide Brayton power  
107 cycle. Noteworthy is the very recent work of Schmidt and Linder [2017], in which an integration  
108 option of the TCS system into a CSP plant has been proposed and analyzed. Their analysis showed  
109 that a storage efficiency up to 87% might be reached when the required steam production during  
110 discharge is thermally integrated into the Rankine steam cycle.

111  
112 From the above literature survey, one may find that the research on how to integrate the  
113 TCS system to the power cycle of the CSP plant is insufficient. Actually, it is an essential issue for  
114 the implementation and application of TCS technology, calling for deeper and extensive  
115 investigations. The main objectives and originalities of this paper are therefore threefold: (1) to  
116 propose various novel integration concepts of TCS system into the Rankine cycle driven by CSP,  
117 for both charging and discharging stages; (2) to perform a detailed energy analysis of the proposed  
118 integrated concepts and to evaluate impacts of various influencing factors on the overall energy  
119 efficiency of the CSP plant; and (3) to discuss and compare the second law efficiency of the proposed  
120 integration concepts through an exergy analysis.

121  
122 This paper is organized as follows. In section 2, the selected gas-solid reaction and material  
123 are briefly introduced and the key issue on how to manage the water vapor from the TCS reactor is

124 identified. Three novel TCS integration concepts (thermal integration, mass integration and turbine  
125 integration) are proposed and described in section 3. The performance modelling of the three  
126 integration concepts based on energy analysis is presented and discussed in section 4. Section 5  
127 provides an exergy analysis of the integration concepts. Finally, main conclusions and future work  
128 are summarized in section 6.

## 130 2. Thermochemical reaction and its operation

131  
132 In this section, we briefly introduce the selected gas-solid reaction and materials, as well as  
133 the identified key issues for the integration of TCS unit into the Rankine cycle.

### 134 2.1. Reaction used as TCS storage media

135  
136  
137 Various hydrates and hydroxides have been proposed as potential TCS materials, as  
138 summarized in some latest papers [e.g., Aydin 2015; André 2016; Liu 2016; Prieto 2016; Pelay 2017a;  
139 Zhang 2016]. Among them, the CaO/H<sub>2</sub>O couple has been deeply studied with a great amount of  
140 experimental feedback [e.g., Azpiazu 2003; Michel 2012; Schaube 2013a; b; Pardo 2014b; Yan 2016;  
141 2017; Sakellariou 2017]. It is found to be a pertinent candidate as TCS material for CSP application  
142 with various features, including for high-temperature use (450~600 °C), good reversibility,  
143 operating pressure close to the atmospheric pressure, low material cost, environment-friendly and  
144 high energy density (about 3 GJ·m<sup>-3</sup>), etc. As a result, it is selected *a priori* for this conceptual study.  
145 The reaction formula is shown in Eq. (2).

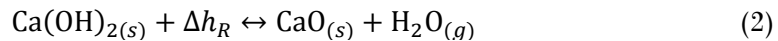

147  
148 For a reaction temperature at 500 °C, the equilibrium pressure equals to 0.1 MPa (1 bar).  
149 Under this condition, the reaction heat ( $\Delta h_R$ ) is found to be 104 kJ·mol(CaO)<sup>-1</sup>=5774.56 kJ·Kg(H<sub>2</sub>O)<sup>-1</sup>  
150 [Schaube, 2011].

### 151 2.2. Management of the water vapor from the TCS reactor

152  
153  
154 The integration of TCS reactor in a solar power plant is a so-called passive concept in which  
155 the storage medium (CaO) is kept motionless and heated-up or cooled-down by the circulation of a  
156 heat transfer fluid (HTF) [Pelay 2017a]. When used as TCS material in a CSP plant, water vapor at  
157 high temperature produced by the decomposition during the charging stage should preferably be  
158 condensed to saturated liquid and stored in a separate reservoir at ambient pressure (0.1 MPa).  
159 Hence the required volume for the storage unit is greatly reduced. Meanwhile, the superheated  
160 steam (500 °C) contains a significant amount of thermal energy, a part of which is possible to be  
161 recovered so as to increase the overall efficiency of the whole system, as shown in Fig. 1a. Instead  
162 of condensing the water vapor directly at the outlet of the TCS reactor by an additional condenser,  
163 alternative energy valorization options are actually available, either to produce extra electricity  
164 through an additional turbine or to preheat the steam of the Rankine cycle.  
165

166  
167  
168  
169  
170  
171  
172  
173  
174  
175  
176  
177

During the discharging stage, the exothermic synthesis happens when CaO and water vapor are in contact. Supposing that the CSP plant is driven only by solar energy, it is necessary to find a heat source to vaporize water stored previously in the liquid form through an evaporator, as shown in Fig. 1b. This heat source should have a higher temperature than that of liquid water to be evaporated (e.g., 100 °C at 1 bar).

As a result, the positioning of TCS reactor in the whole system and the way of managing water vapor are key issues for an energy-efficient integration of TCS unit into the Rankine cycle. Different integration concepts shown in the following section will highlight the options proposed for these key points.

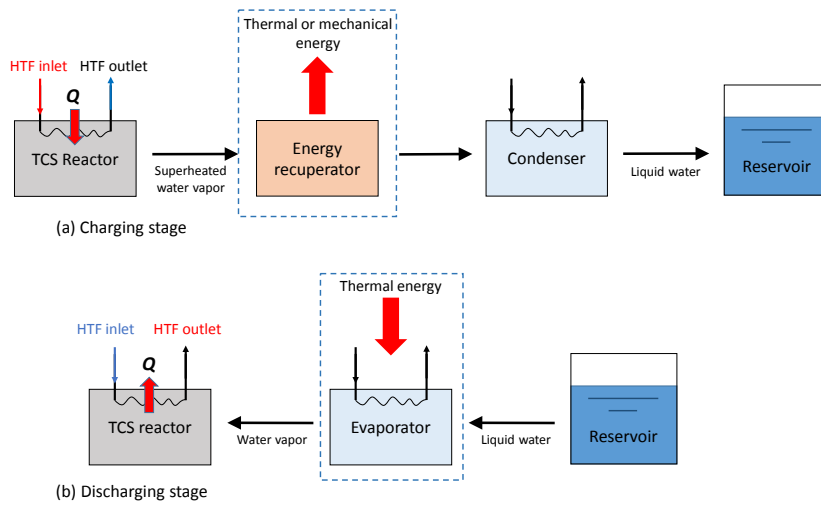

178  
179  
180  
181  
182

Figure 1. Management of water vapor as a key issue for energy-efficient TCS integrations into the Rankine cycle. (a) charging stage; (b) discharging stage.

183  
184

### 3. TCS integration concepts

185  
186  
187  
188

In this section, we shall firstly present a conventional regenerative Rankine cycle driven by CSP without storage as a reference case [Moran, 2003]. Then, three novel integration concepts of TCS unit into the Rankine cycle are proposed and described, named as thermal integration, mass integration and turbine integration.

189  
190

#### 3.1. Conventional Rankine cycle without TES

191  
192

Figure 2 shows a representative schematic view of the conventional regenerative Rankine cycle driven by CSP. The main components in this cycle include a steam generator, a turbine, a condenser, an open feedwater heater and pumping and piping accessories. Solar energy is firstly absorbed by the solar receiver at the top of solar tower and transferred to the HTF. This amount of thermal energy is then utilized in converting water contained in generator (point 6) into superheated steam at the suitable pressure and temperature (point 1). The superheated steam then flows through

199 the turbine. While doing work in the turbine, the pressure of steam is reduced. The steam leaving  
 200 the turbine (point 2) passes through the condenser and is condensed into liquid at low pressure for  
 201 recycling. An open (or direct-contact) feedwater heater serves as a mixing chamber where the steam  
 202 extracted from the turbine (point 2') mixes with the feedwater leaving the pump (point 4). Ideally,  
 203 the mixture leaves the heater as the saturated liquid at the heater pressure (point 5). This steam  
 204 regeneration configuration usually enhances the thermal efficiency of the Rankine cycle at the cost  
 205 of lower electricity production rate due to steam extraction.  
 206

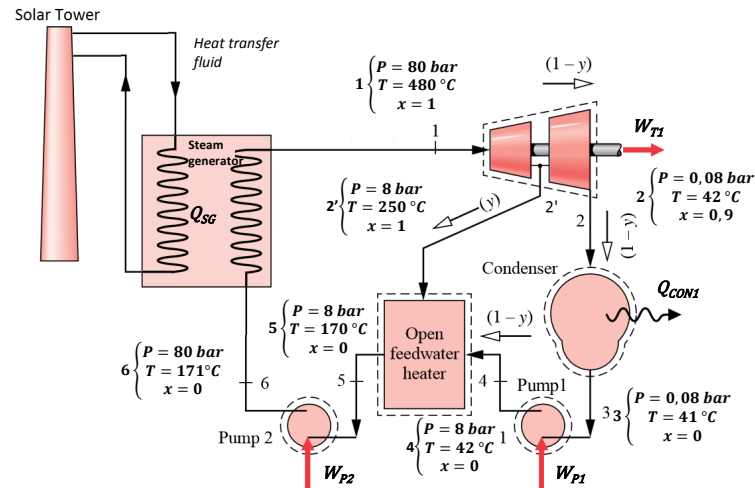

207  
 208 Figure 2. Schematic view of a conventional regenerative Rankine cycle driven by CSP without TES [Moran 2003]

209  
 210

### 211 3.2. Concept 1: Thermal integration (Thermal Int.)

212

213 The Thermal Int. concept is shown in Fig. 3. The added TCS unit comprises of a TCS reactor,  
 214 a water reservoir, a second condenser and two heat exchangers. There are three fluid circuits in the  
 215 integrated system: the solar circuit as energy supply, the principal Rankine circuit for power  
 216 generation and the TCS circuit for energy storage. Note that although the working fluids are  
 217 identical as pure water or steam, the principal Rankine circuit and the TCS circuit are independent  
 218 of each other without direct mass contact or exchange. Hence, this concept is named as Thermal  
 219 Int. because there is only heat exchange between the TCS circuit and the Rankine circuit.  
 220

221

222 During the charging stage (Fig. 3a), the HTF (e.g., pressurized air or molten salt) from the  
 223 solar tower offers the steam generator sufficient amount of thermal energy to run the principal  
 224 Rankine cycle. Meanwhile, it heats the  $\text{Ca(OH)}_2$  reactive salts in the TCS reactor up to 500 °C at 1  
 225 bar to initiate the decomposition. The water vapor generated in the TCS reactor is partially  
 226 condensed in the heat exchanger 1, then completely condensed in the condenser 2 and finally be  
 227 stored as the saturated liquid (100 °C, 1 bar) in a separate water reservoir. The sensible and latent  
 228 heat released by the water vapor will be used to preheat the working fluid of the principal Rankine  
 229 circuit via heat exchanger 1. The CaO reaction product (and subsequent reactant) remains in the  
 230 TCS reactor. This integration concept permits the steady operation of the principal Rankine circuit  
 231 for power production and the TES in parallel.

231

232 During the discharging stage (Fig. 3b) when solar energy is not available, the liquid water  
 233 stored in the reservoir is firstly heated up and vaporized by the high temperature steam extracted  
 234 from the turbine of the principal Rankine circuit via the heat exchanger 2. The saturated vapor  
 235 (100 °C, 1 bar) enters then into the TCS reactor and reacts with the CaO for the synthesis of Ca(OH)<sub>2</sub>.  
 236 The heat released from this exothermic reaction in the TCS reactor runs the principal Rankine cycle  
 237 steadily under the same operational conditions (temperature, pressure and steam mass flow-rate) as  
 238 during the charging stage. In this case, the TCS reactor also serves as the steam generator.

239  
 240 The positive aspect of this concept is that it is technically simple to implement whereas the  
 241 disadvantage is that a separate reservoir is required to store the liquid water resulting from the TCS  
 242 reaction, implying a higher capital cost.

243

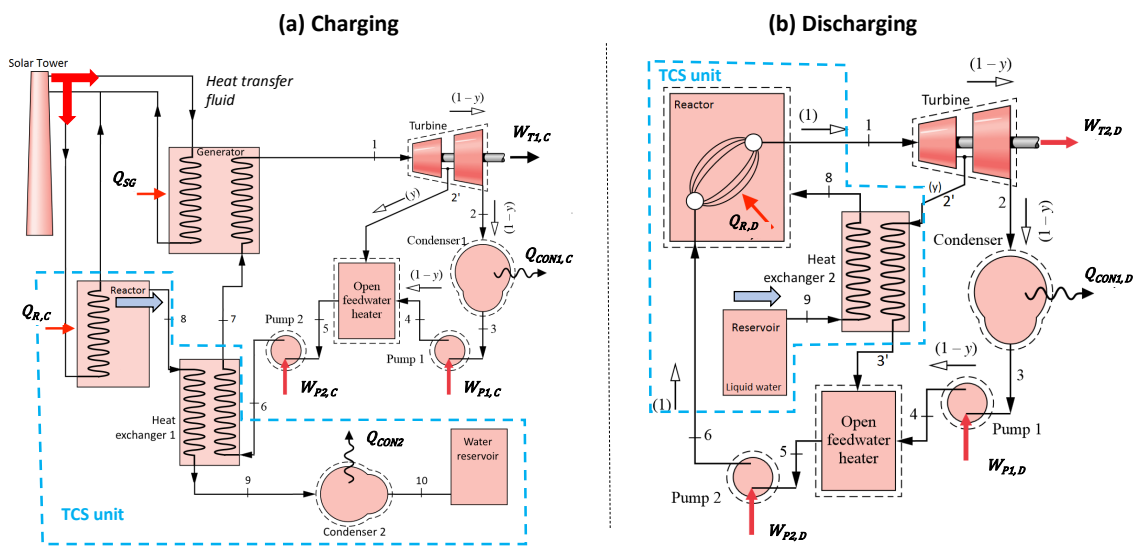

244  
 245 Figure 3. Schematic view of the thermal integration concept. (a) charging stage; (b) discharging stage [Luo 2016].

246

247

### 248 3.3. Concept 2: Mass integration (Mass Int.)

249

250 The Mass Int. concept is shown in Fig. 4. Compared to the conventional Rankine cycle as  
 251 shown in Fig. 2, a TCS unit is added including a TCS reactor, a second condenser, a throttle valve,  
 252 a third pump and two heat exchangers. There are still three fluid circuits in the installation: the  
 253 solar circuit, the principal Rankine circuit and the TCS circuit. But different from the above-  
 254 mentioned Thermal Int. concept, the principal Rankine circuit and the TCS circuit are coupled and  
 255 share the same working fluid (pure water or steam) with mass exchange. As a result, this concept is  
 256 named as Mass Int.

257

258 During the charging stage (Fig. 4a), the water vapor generated in the TCS reactor is partially  
 259 condensed in the heat exchanger 1, depressurized by the throttle valve, completely condensed in the  
 260 condenser 2 and finally stored as the saturated water (41 °C, 0.008 MPa) in the water reservoir  
 261 shared with the principal Rankine circuit. The sensible and latent heat released by the common



262 water vapor will be used to preheat the working fluid of the Rankine cycle via the heat exchanger 1  
 263 located upstream of the steam generator.

264

265 During the discharging stage (Fig. 4b), the liquid water stored in the reservoir will be  
 266 pressurized by pump 3 and then evaporated by exchanging heat with the extracted steam via the  
 267 heat exchanger 2. The saturated vapor (100 °C, 0.1 MPa) enters the TCS reactor and reacts with the  
 268 CaO reactive salts stored inside. Again, the TCS reactor serves as the steam generator to run the  
 269 Rankine cycle steadily under the same operational conditions as during the charging stage.

270

271 The Mass Int. concept seems less interesting than the Thermal Int. concept because more  
 272 components are required for the TCS unit, implying higher capital costs. Moreover, the mixing of  
 273 working fluids between the principal Rankine circuit and the TCS circuit could bring further  
 274 technical difficulties because of the massive fines formation. An efficient filtration system (e.g.,  
 275 sintered metal fiber or ceramic filters [Smolders 2000]) may have to be implemented for dust removal  
 276 to prevent the eventual damage of the turbine. A special design of the TCS reactor coupled with  
 277 metal filter may also be considered [Schmidt 2017].  
 278

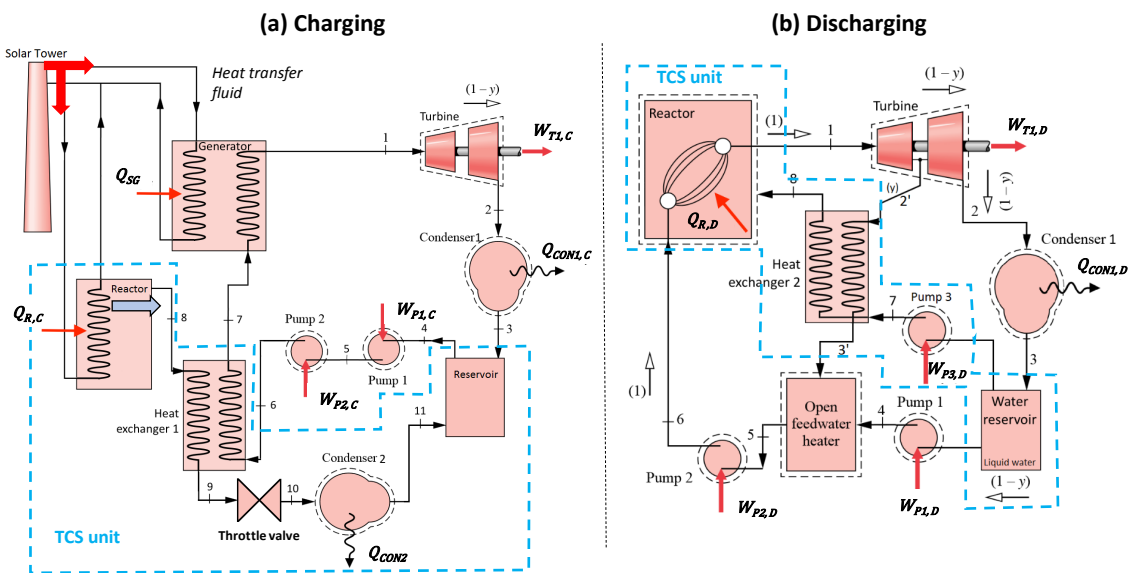

279

280 Figure 4. Schematic view of the mass integration concept. (a) charging stage; (b) discharging stage [Luo 2016].

281

282

### 283 3.4. Concept 3: Turbine integration (Turbine Int.)

284

285 Figure 5 presents a schematic view of the Turbine Int. concept. Additional components of  
 286 the TCS unit include a TCS reactor, a second turbine, a second condenser, a third pump, a water  
 287 reservoir and a heat exchanger. The principal Rankine circuit and the TCS circuit are completely  
 288 independent of each other during the charging stage (no heat or mass exchange) and thermally  
 289 coupled during the discharging stage.

290

291 During the charging stage (Fig. 5a), the water vapor generated in the TCS reactor passes  
 292 through the turbine 2, condensed in the condenser 2 and finally stored as the sub-saturated water

293 (41.5 °C, 0.1 MPa) in a water reservoir. A part of its thermal energy is valorized as power production  
 294 via the second turbine. The integration concept for the discharging stage (Fig. 5b) is the same as  
 295 that of Thermal Int. concept, in which water stored in the reservoir will be evaporated by  
 296 exchanging heat with the extracted steam via the heat exchanger 2.

297

298 The main feature of this concept is the additional power production in parallel of the one  
 299 provided by the principal Rankine circuit during the charging stage. However, the implementation  
 300 of this second turbine, which is partially used only during the charging stage, implies higher capital  
 301 cost for the CSP plant.

302

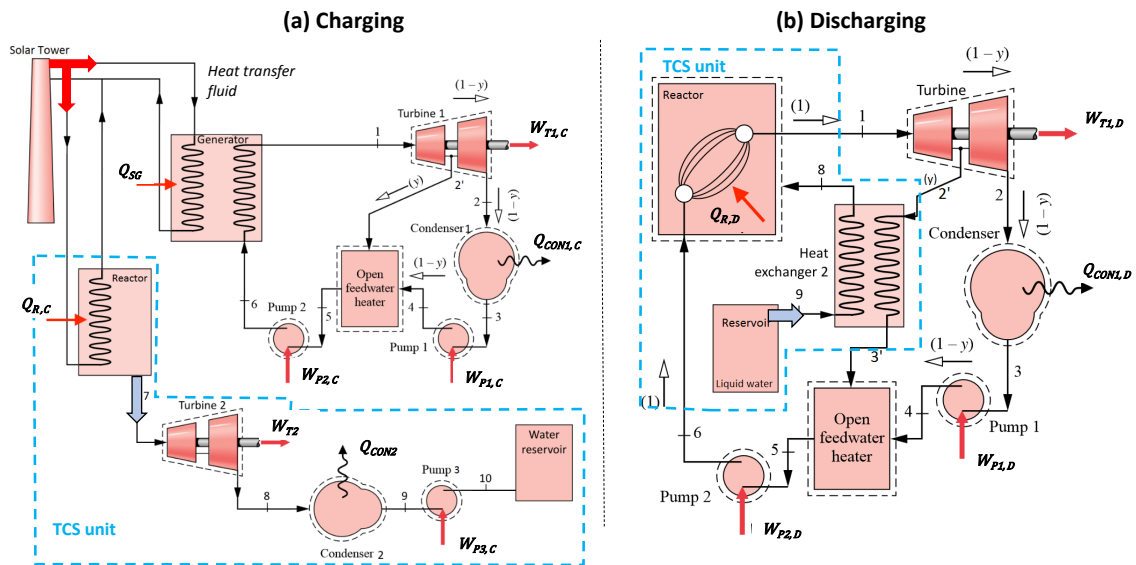

303

304 Figure 5. Schematic view of the turbine integration concept. (a) charging stage; (b) discharging stage [Luo 2016].

305

306

#### 307 4. Energy analysis of different TCS integration concepts

308

309 This section presents a detailed energy analysis of three proposed concepts of TCS  
 310 integration into the Rankine cycle of a CSP plant. Firstly, the performance modelling of each  
 311 individual components and of the system as a whole will be described under ideal operating  
 312 conditions (as indicated in Fig. 1). Then a parametric study on various influencing factors will be  
 313 performed so as to identify appropriate functioning points for different integration concepts towards  
 314 performance comparison.

315

316

##### 317 4.1. Performance modelling

318

319 The performance analysis is based on the conservation of mass and energy. To simplify the  
 320 calculation, the following assumptions are made, while the influences of certain factors will be  
 321 discussed through the parametric study in the later section. Note that the solar receiver and the  
 322 solar tower have not been included in the current analysis. It is supposed that the solar field provides

323 the required amount of thermal energy for the power production of the Rankine cycle and the TES  
324 during the charging stage.

325

326 (A1) Steady-state operation;

327 (A2) Isentropic compression and expansion processes ( $\eta_{isen}=1$ );

328 (A3) Evaporation and condensation at constant pressure;

329 (A4) Negligible heat loss; negligible pressure drop of piping system;

330 (A5) During the charging, the water vapor at 500 °C and 0.1 MPa is released from the TCS  
331 reactor; during the discharging, the saturated vapor (100 °C, 0.1 MPa) is injected into  
332 the TCS reactor; 100% conversion rate of the TCS reactor ( $\nu=1$ ), no mass leakage  
333 during the storage;

334 (A6) The power output rate from the turbine of the principal Rankine circuit  $W_{T1} = 100 \text{ MW}_{el}$ .

Table I. Mass and energy conservation equations for the performance modelling of Rankine cycle with or without TCS integration.

Component	Reference case	Thermal Int.		Mass Int.		Turbine Int.		Note	
		charging	discharging	charging	discharging	charging	discharging		
Principal Rankine circuit	Turbine 1 (T1)	$T_{T1}^{in} = 480 \text{ }^\circ\text{C}$ , $P_{T1}^{in} = 8.0 \text{ MPa}$ ; $P_{T1}^{out} = 0.008 \text{ MPa}$ ; $P_{T1}^{ext} = 0.08 \text{ MPa}$ $W_{T1,C(D)} = m_{Rankine,C(D)} [(h_{T1}^{in} - h_{T1}^{ext}) + (1 - y_{C(D)})(h_{T1}^{ext} - h_{T1}^{out})]$ (3) $\eta_{T1,C(D)} = \frac{h_{T1}^{ext} - h_{T1}^{in}}{h_{T1,isen}^{ext} - h_{T1}^{in}} = \frac{h_{T1}^{out} - h_{T1}^{ext}}{h_{T1,isen}^{out} - h_{T1}^{ext}}$ (4)						N1	
	Condenser 1 (CON1)	$Q_{CON1,C(D)} = m_{Rankine,C(D)}(1 - y_{C(D)})(h_{CON1}^{in} - h_{CON1}^{out})$ (5) $P_{CON1}^{in} = P_{CON1}^{out}$						N2	
	Pump 1 (P1)	$W_{P1,C(D)} = m_{Rankine,C(D)}(1 - y_{C(D)})(h_{P1}^{out} - h_{P1}^{in})$ (6) $\eta_{P1,C(D)} = \frac{h_{P1,isen}^{out} - h_{P1}^{in}}{h_{P1}^{out} - h_{P1}^{in}}$ (7)						N3	
	Feedwater heater (FH)	$y_{C(D)}h_{FH}^{in1} + (1 - y_{C(D)})h_{FH}^{in2} = h_{FH}^{out}$ (8) $P_{FH}^{in1} = P_{FH}^{in2} = P_{FH}^{out}$ (9)		-	-	(8) (9)			
	Pump 2 (P2)	$W_{P2,C(D)} = m_{Rankine,C(D)}(h_{P2}^{out} - h_{P2}^{in})$ (10) $\eta_{P2,C(D)} = \frac{h_{P2,isen}^{out} - h_{P2}^{in}}{h_{P2}^{out} - h_{P2}^{in}}$ (11)						N4	
	Steam generator (SG)	$Q_{SG} = m_{Rankine}(h_{SG}^{out} - h_{SG}^{in})$ (12) $P_{SG}^{in} = P_{SG}^{out}$ (13)		-	(12) (13)	-	(12) (13)	-	
TCS circuit	TCS reactor (R)	-	$\gamma Q_{R,C} = m_{TCS,c}\Delta h_R$ (14)	$Q_{R,D} = \gamma m_{TCS,D}(h_{R,D}^{out} - h_{R,D}^{in})$ (15)	(14)	(15)	(14)	(15)	N5
	Condenser 2 (CON2)	-	$Q_{CON2} = m_{TCS,c}(h_{CON2}^{in} - h_{CON2}^{out})$ (18) $P_{CON2}^{in} = P_{CON2}^{out} = 0.1 \text{ MPa}$ (19)	-	(18)	-	(18) (20)	-	
	Heat exchanger 1 (HX1)	-	$\frac{h_{HX1,Rankine}^{out}}{m_{Rankine,C}}(h_{HX1,TCS}^x - h_{HX1,TCS}^y) + h_{HX1,Rankine}^{in}$ (21) $\frac{h_{HX1,TCS}^{out}}{m_{Rankine,C}}(h_{HX1,Rankine}^y - h_{HX1,Rankine}^x) + h_{HX1,TCS}^{in}$ (22)	-	(21) (22)	-	-	-	N6
	Heat exchanger 2 (HX2)	-	-	$m_{TCS,D}(h_{HX2,TCS}^{out} - h_{HX2,TCS}^{in}) =$	-	(23)	-	(23)	

				$y_D m_{Rankine,D} (h_{HX2,Rankine}^{in} - h_{HX2,Rankine}^{out})$ (23)				
Water reservoir (WS)	-	Saturated water at 0.1 MPa		Saturated water at 0.008 MPa		Sub-saturated water (41.5 °C) at 0.1 MPa		N7
Throttle valve (TV)	-	-	-	$h_{TV}^{in} = h_{TV}^{out}$ $P_{TV}^{in} = 0.1$ MPa; $P_{TV}^{out} = 0.008$ MPa (24)		-	-	
Pump 3 (P3)	-	-	-	-	$P_{P3}^{in} = 0.008$ MPa; $P_{P3}^{out} = 0.1$ MPa $W_{P3,C(D)} = m_{TCS,C(D)} (h_{P3}^{out} - h_{P3}^{in})$ (25) $\eta_{P3,C(D)} = \frac{h_{P3,isen}^{out} - h_{P3}^{in}}{h_{P3}^{out} - h_{P3}^{in}}$ (26)		-	
Turbine 2 (T2)	-	-	-	-	-	$P_{T2}^{out} = 0.008$ MPa $W_{T2} = m_{TCS} (h_{T2}^{in} - h_{T2}^{out})$ (27) $\eta_{T2} = \frac{h_{T2}^{out} - h_{T2}^{in}}{h_{T2,isen}^{out} - h_{T2}^{in}}$ (28)		-
Overall energy efficiency of the installation	$\frac{\eta_o = W_{T1} - W_{P1} - W_{P2}}{Q_{SG}}$ (29)	$\eta_o = \frac{(W_{T1,C} - W_{P1,C} - W_{P2,C})H_C + (W_{T1,D} - W_{P1,D} - W_{P2,D})H_D}{(Q_{SG} + Q_{R,C})H_C}$ (30)		$\eta_o = \frac{(W_{T1,C} - W_{P1,C} - W_{P2,C})H_C + (W_{T1,D} - W_{P1,D} - W_{P2,D} - W_{P3,D})H_D}{(Q_{SG} + Q_{R,C})H_C}$ (31)		$\eta_o = \frac{(W_{T1,C} + W_{T2,C} - W_{P1,C} - W_{P2,C} - W_{P3,C})H_C + (W_{T1,D} - W_{P1,D} - W_{P2,D})H_D}{(Q_{SG} + Q_{R,C})H_C}$ (32)		N8
<p>N1: saturated steam at the turbine extraction; <math>y_C=0</math> for Mass Int. concept.</p> <p>N2: <math>y_C=0</math> for Mass Int. concept.</p> <p>N3: saturated water at the inlet of P1; <math>y_C=0</math> for Mass Int. concept.</p> <p>N4: <math>T_{P2}^{in} = 41.6</math> °C for the discharging stage of Thermal Int. and Mass Int.; saturated water for the rest of concepts.</p> <p>N5: <math>H_C</math> and <math>H_D</math> are the number of operating hours for charging and for discharging, respectively; <math>\gamma</math> is the conversion rate of the TCS reactor; Eq. (15) implies that a portion of reaction heat is consumed to heat the saturated vapor (100 °C 0.1 MPa) to the equilibrium temperature of reaction (500 °C 0.1 MPa).</p> <p>N6: <math>X</math> and <math>Y</math> are intermediate points located at the hot side (TCS) and cold side (Rankine) of the HX1, respectively; saturated steam at <math>X</math> point; <math>T_{HX1,TCS}^{out} - T_{HX1,Rankine}^Y = 5</math> °C (pinch point of HX1).</p> <p>N7: no thermal losses during the storage period.</p> <p>N8: <math>Q_{SG}</math> and <math>Q_{R,C}</math> are the amount of heat provided by the HTF; the solar field (solar receiver) is not included in the analysis.</p>								

324 Mass and energy conservation equations for the individual components and for the whole  
 325 system of different concepts are listed in Table 1. Values of thermodynamic properties of water and  
 326 steam are determined referring to NIST-JANAF Thermochemical Tables [Chase, 1998]. Detailed  
 327 values of main status points of the Rankine cycle with or without TCS integration may be found in  
 328 the supplementary material of this paper.

329  
 330 Following this modeling procedure, the global performance of three proposed integration  
 331 concepts is analyzed and compared with that of conventional Rankine cycle without storage  
 332 (reference case). The charging/discharging scenarios examined cover a large variety of operation  
 333 possibilities, for the charging time ( $H_C$ ) varying from 1 hour to 12 hours and the discharging time  
 334 ( $H_D$ ) varying from 0 hour to 13 hours.

335  
 336 Figure 6 shows the overall energy efficiency of the installation ( $\eta_o$ ) for different integration  
 337 concepts under the above-mentioned ideal operational conditions, for various charging (Fig. 6b) and  
 338 discharging (Fig. 6a) scenarios.  $\eta_o$  is defined as the total net output work of the Rankine cycle  
 339 (during charging and discharging) divided by all the energy absorbed from the HTF of the solar  
 340 circuit (during charging), as indicated in Eqs. 29-32.

341  
 342 It can be observed from Fig. 6a that for a given charging time ( $H_C=11$  h), the values of  $\eta_o$   
 343 with TCS integration are lower than that of the reference case ( $\eta_{o,ref}=0.42$ ) without TCS. This can  
 344 be explained by the loss of a part of the energy contained in the superheated vapor produced by the  
 345 TCS reactor during the charging hours. A large part of the energy is recovered/valorized via the heat  
 346 exchanger 1 (Thermal Int. and Mass Int.) and via the turbine 2 (Turbine Int.). But still, a small part  
 347 is lost in the condenser 2. It can also be observed in Fig. 6a that the Turbine Int. has the highest  $\eta_o$   
 348 while the Mass Int. has the lowest. This difference becomes more important with the increasing  
 349 number of discharging hours. Figure 6b shows that for a given discharging time ( $H_D=12$  h), the  $\eta_o$   
 350 of all concepts of TCS integration increases when the number of charging hours ( $H_C$ ) increases. It  
 351 seems that a low  $H_D/H_C$  ratio is favorable to achieve high values  $\eta_o$  when TCS unit is integrated into  
 352 the CSP plant.

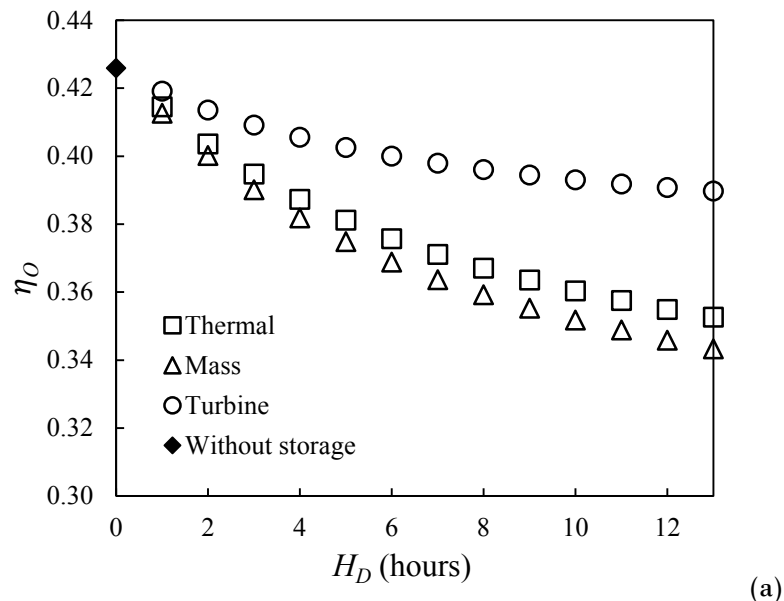

353

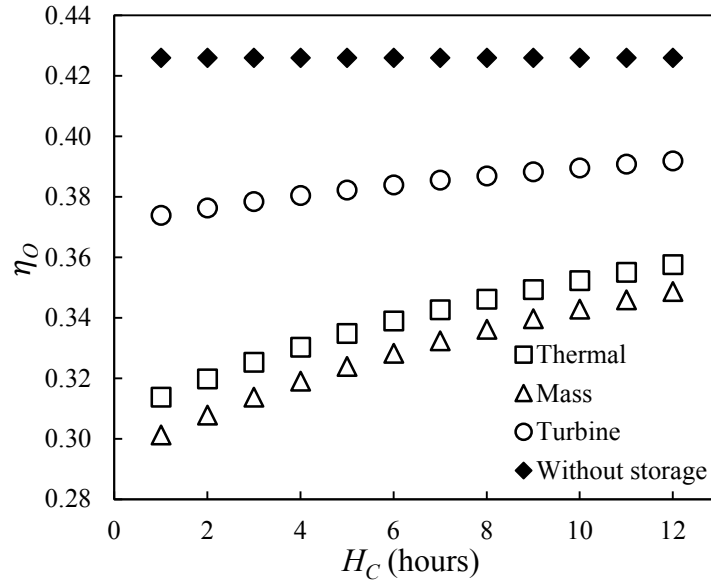

(b)

Figure 6. Overall energy efficiency of the installation ( $\eta_0$ ) for different integration concepts under ideal operational conditions. (a) different number of discharging hours ( $H_c=11$  h); (b) different number of charging hours ( $H_b=12$  h).

354  
355  
356  
357  
358  
359  
360  
361  
362  
363  
364  
365  
366  
367

However, longer discharging shows clear advantages in terms of higher dispatchability and higher total power output. As shown in Fig. 7, the daily power output of Turbine Int. could reach 3010 MWh<sub>el</sub> for 11 hours of charging and 13 hours of discharging (round-the-clock operation), which is augmented by a factor of 2.7 compared to that of the reference case without storage (only 11 hours daily production). The benefits of TCS integration into the CSP plant are therefore highlighted. In real world practice, the operation strategy of the TCS unit certainly deserves detailed investigations by taking various influencing factors into account (e.g., climate condition for charging hour, electricity demand profile for the discharging hour, hourly electricity price for techno-economic consideration, etc.).

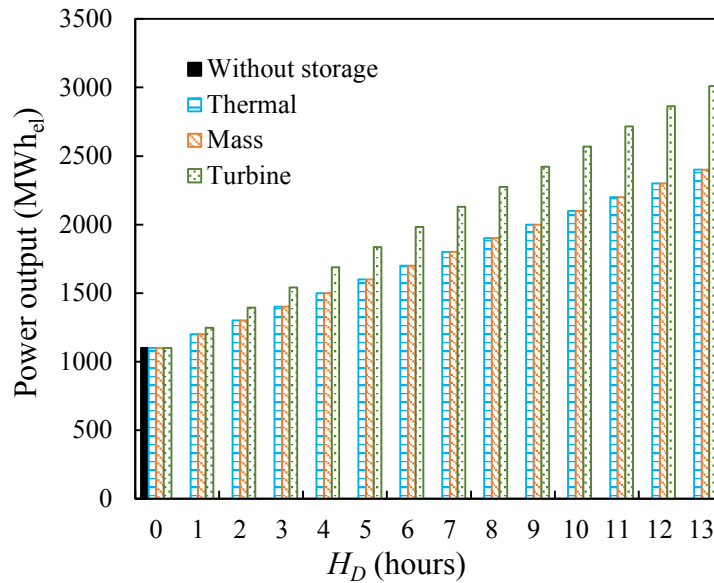

Figure 7. Power production of CSP plants as a function of the number of discharging hours ( $H_c=11$  h).

368  
369  
370  
371

372

## 373 4.2. Parametric study

374

375 It should be noted that in section 4.1, the overall energy efficiency is estimated under ideal  
376 conditions, neglecting all the losses. From the viewpoint of real-world engineering, it is necessary to  
377 evaluate the real performances when actual operational conditions differ from the ideal one. In this  
378 section, the impacts of various influencing factors on the overall energy efficiency of the plant are  
379 analyzed and discussed. The studied parameters include the isentropic efficiency of turbomachines  
380 (turbines and pumps), the steam temperature at the inlet of turbine 1 and the global efficiency of  
381 the TCS reactor. Note that to evaluate the separate effect of a certain parameter, only the concerned  
382 parameter is varied while others are kept as the ideal operational conditions used for performance  
383 modelling in section 4.1.

384

- 385 • *Isentropic efficiency of turbomachines  $\eta_{isen}$*

386

387 We define the parameter  $\eta_{isen}$  as the isentropic efficiency of turbine or pumps, to represent  
388 non-isentropic compression or expansion processes. Different values of  $\eta_{isen}$  from 0.5 to 1.0 are tested  
389 and added to the relevant energy conservation equations for turbines and pumps to determine the  
390 values of main status points of the cycle. Note that for simplification purpose, the equal value of  
391  $\eta_{isen}$  is assumed for all turbomachines.

392

393 Figure 8 represents the variation of  $\eta_o$  values for different concepts as a function of the  
394 isentropic efficiency of turbomachines. The negative effect of non-isentropic compression/expansion  
395 of turbines and pumps can be clearly observed. Each 10% decrement of  $\eta_{isen}$  results in about 4.2-  
396 4.5% reduction in the  $\eta_o$ .

397

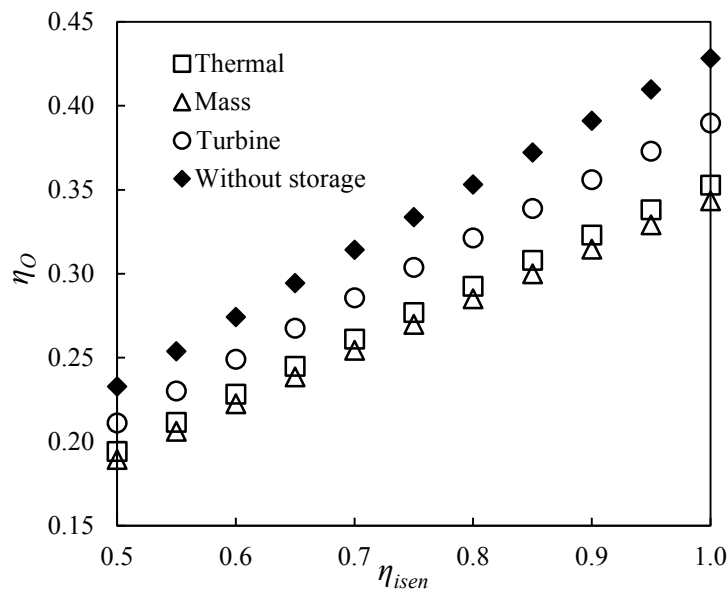

398

399 Figure 8. Overall energy efficiency ( $\eta_o$ ) as a function of the isentropic efficiency ( $\eta_{isen}$ ) of turbines and pumps ( $H_c=11$  h;

400

$H_D=13$  h).

401



402  
 403  
 404  
 405  
 406  
 407  
 408  
 409  
 410

- *Steam temperature at the inlet of turbine 1*

Increasing the steam temperature at the inlet of turbine 1 ( $T_{T1}^{in}$ ) means the increased temperature of the superheated steam at the outlet of the steam generator (during charging) and the TCS reactor (during discharging). This usually leads to the augmented turbine work output. It may be observed from Fig. 9 that the  $\eta_o$  value increases almost linearly with the increasing  $T_{T1}^{in}$  for all the studied concepts.

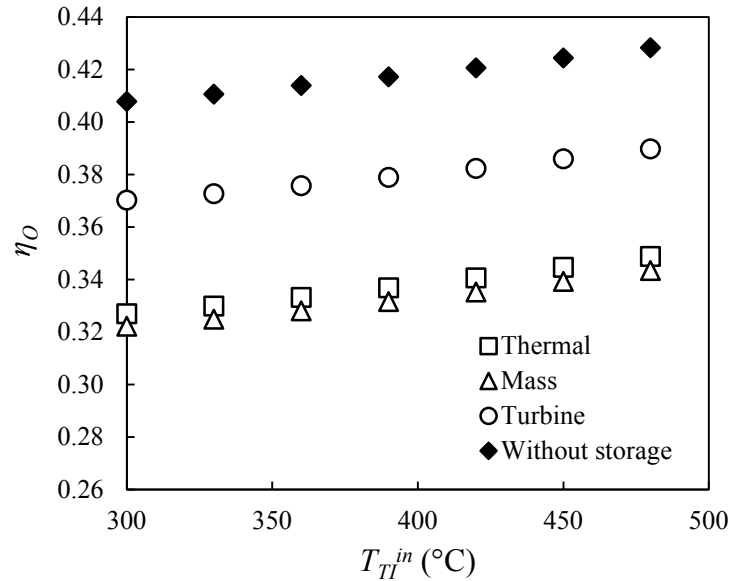

411

Figure 9. Overall energy efficiency ( $\eta_o$ ) as a function of the steam inlet temperature of the turbine T1 ( $H_C=11$  h;  $H_D=13$  h).

412  
 413  
 414

However, an excessive increase of  $T_{T1}^{in}$  may cause the turbine damage. Moreover, higher  $T_{T1}^{in}$  requires higher HTF temperature of the solar circuit during the charging and the higher reaction temperature of the TCS reactor during the discharging. Since the equilibrium temperature of  $\text{Ca}(\text{OH})_2$  synthesis is related to the pressure (e.g., 540 °C at 0.2 MPa) [Schaube 2012; Zhang 2016], the TCS reactor may have to be pressurized to render higher reaction temperature. This imposes a higher requirement on the TCS reactor design and operation as well as the more complicated control strategy for the whole installation. As a result,  $T_{T1}^{in} = 480$  °C (500 °C, 0.1 MPa for the TCS reactor) is selected as an appropriate operational parameter.

422  
 423  
 424

- *TCS reactor efficiency  $\gamma$*

425  
 426  
 427  
 428  
 429  
 430  
 431  
 432

Another influencing factor is the reactor's efficiency, which is defined as the ratio of the effective heat released to the theoretical reaction heat for discharging, or the ratio of the theoretical heat needed to the effective heat absorbed for charging. This factor is closely linked with various aspects including the structure and size of the reactor, the reversibility of the TCS reaction and the chemical stability of the stored materials. Since it is difficult at this stage to quantify the respective impact of each aspect, we introduce the parameter  $\gamma$  as the *global TCS reactor efficiency* taking all

433 the related effects into account. We also assume identical  $\gamma$  for charging and for discharging, as  
 434 indicated in Table 1. Note that the assumption of constant and identical  $\gamma$  values may not be  
 435 appropriate in real practice, since the reversibility of the CaO/Ca(OH)<sub>2</sub> pair will decrease with the  
 436 increasing number of operation cycles.

437

438 Figure 10 shows the calculated results of  $\eta_o$  as a function of the global TCS reactor efficiency  
 439  $\gamma$ . It can be observed that the  $\eta_o$  value decreases with the reduced global reactor efficiency. When  $\gamma$   
 440 of the TCS reactor drops from 1.0 to 0.8, the  $\eta_o$  value decreases about 5% for Turbine Int., and  
 441 about 7% for Mass Int. and for Thermal Int. Turbine Int. concept still has the best overall energy  
 442 efficiency.

443

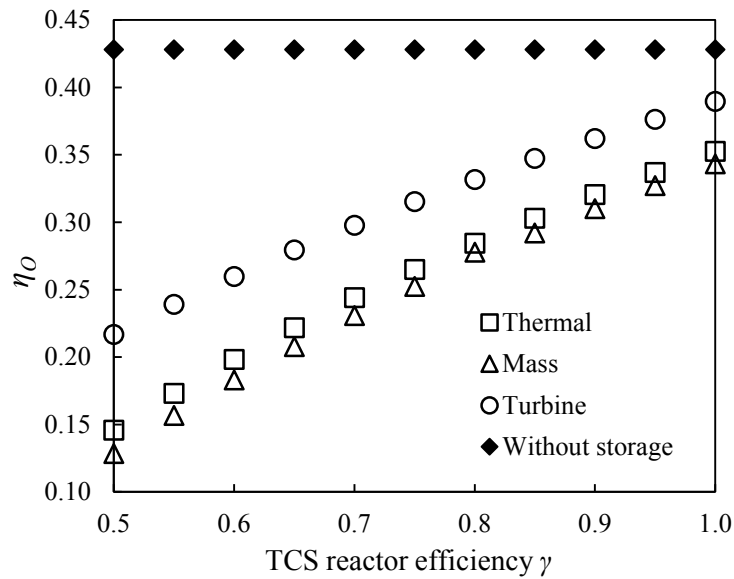

444

445 Figure 10. Overall energy efficiency ( $\eta_o$ ) as a function of the TCS reactor efficiency  $\gamma$  ( $H_c=11$  h;  $H_D=13$  h).

446

447 Besides the negative impact on the overall energy efficiency, the losses that we studied will  
 448 also increase the amount of storage materials needed, thus requiring a larger size of the TCS reactor  
 449 for their storage and operation. In real world engineering, special attention should be given to avoid  
 450 or minimize the losses to a lower limit.

451

452

### 453 4.3. Comparison of 3 proposed integration concepts

454

455 The parametric study carried out in section 4.2 permits evaluating the impacts of some  
 456 influencing factors on the overall energy efficiency and determining more realistic operational  
 457 conditions with respect to the ideal conditions used for performance modelling in section 4.1. Based  
 458 on the results obtained, a comparison of the three proposed integration concepts under more realistic  
 459 operational conditional is presented in Table 2. Note that detailed values of various parameters are  
 460 obtained under the assumptions of  $\eta_{isen}=0.85$ ,  $T_{T1}^{in} = 480$  °C,  $\gamma=0.95$ ,  $W_{T1,C(D)} = 100$  MW and  
 461 round-clock operation ( $H_c=11$  h;  $H_D=13$  h).

462

463           A size estimation of the TCS unit has been made and the results are recapitulated in Table  
464 2. It is shown that the Thermal Int. concept needs a smaller quantity of TCS material (9571 t) than  
465 the Mass Int. (10013 t) and the Turbine Int. (9998 t) for 13 hours discharging time. It is because the  
466 water vapor from the TCS reactor is stored as saturated liquid (100 °C, 0.1 MPa) for the Thermal  
467 Int. whereas for Mass Int. and Turbine Int. concepts, the water is stored at 41.5 °C. Therefore, a bit  
468 more quantity of TCS materials is needed for the latter two concepts to compensate this temperature  
469 difference.

Table 2. Comparison on the energy performance of three proposed integration concepts under more realistic operating conditions ( $\eta_{isen}=0.85$ ,  $T_{T1}^{in} = 480$  °C,  $\gamma=0.95$ ,  $W_{T1,C(D)} = 100$  MW and round-clock operation ( $H_C=11$  h;  $H_D=13$  h).

		$\eta_o$	Operational data			Heat exchange rate						Work exchange rate			Size of storage unit	
			$m_{Rankine}$ (kg·s <sup>-1</sup> )	$m_{TCS}$ (kg·s <sup>-1</sup> )	$\gamma$	SG (MW)	CON1 (MW)	CON2 (MW)	HX2 (MW)	HX1 (MW)	R (MW)	T1 (MW)	T2 (MW)	P1+2+3 (MW)	Mass of water stored (t)	Mass of CaO stored (t)
<b>Thermal Int.</b>	Discharging	0.295	144	80	0.67	-	78.0	-	181.4	-	378.7	100	-	1.0	3079	9571
	Charging		91	95	0	190.8	188.7	194.4	-	97.3	548.3	100	-	0.6		
<b>Mass Int.</b>	Discharging	0.286	151	84	0.72	-	87.0	-	210.3	-	396.2	100	-	1.0	3221	10013
	Charging		91	99	0	187.1	188.8	228.3	-	121.2	573.7	100	-	0.6		
<b>Turbine Int.</b>	Discharging	0.327	151	84	0.72	-	87.1	-	210.0	-	395.6	100	-	1.50	3217	9998
	Charging		102	92	0.20	268.3	169.4	251.4	-	-	531.6	100	53.7	1.0		

462 The energy storage density is roughly estimated to be about 100 kWh<sub>el</sub>·t<sup>-1</sup>. This value is  
 463 about seven times higher than that of existing CSP plants using molten salt as energy storage media  
 464 (eg. for Andasol1 Spain, the heat reservoir consists of two tanks measuring 14 m in height and 36 m  
 465 in diameter and containing 28500 tons of molten salts, enough to run the turbine for about 7.5 hours  
 466 at 50 MW<sub>el</sub> [Pelay 2017b]. The energy storage density is calculated to be 13.1 kWh<sub>el</sub>·t<sup>-1</sup>). Higher  
 467 energy storage density implies more compact storage unit and less heat loss of the storage reservoirs.

468  
 469 A first comparison between the three proposed integration concepts can then be made.  
 470 Firstly, the Turbine Int. concept is the most interesting ( $\eta_o=0.327$ ) in terms of overall energy  
 471 efficiency. However, a second turbine is needed, implying the higher initial cost. Particular attention  
 472 should be given to the purity of steam leaving the TCS reactor that may cause the mechanical failure  
 473 of the second turbine. Efficient filtration measures are indispensable for dust removal as has been  
 474 discussed above. Secondly, the Mass Int. concept is the least attractive ( $\eta_o=0.286$ ). In fact, the  
 475 mixing of working fluids between principal Rankine circuit and the TCS circuit may not be a good  
 476 option again due to the purity issue that could be vital to the turbine. Finally, the Thermal Int.  
 477 concept does not possess the highest overall energy efficiency, but its simple and robust design makes  
 478 it relatively easy towards implementation. Moreover, relatively small volumes of reservoirs are  
 479 required based on the size estimation reported above.

480  
 481

## 482 5. Exergy analysis of different TCS integration concepts

483

484 The previous section presents a comparison of the three proposed integration concepts based  
 485 on the energy analysis (first law of thermodynamics). Meanwhile, an exergy balance will also be  
 486 beneficial by providing supplemental insights on the quality of the energy, taking the irreversibility  
 487 notion of the processes into account [Dincer 2002; Rosen 2003; Kang 2018]. The main purpose of  
 488 this section is hence to evaluate and compare the overall exergy efficiency of the three proposed  
 489 integration concepts through an exergy analysis. Note that the exergy analysis and the modelling  
 490 results presented hereafter are obtained under realistic operating conditions ( $\eta_{isen}=0.85$  and  $\gamma=0.95$ )  
 491 as specified in sections 4.3.

492  
 493

### 494 5.1. Performance modelling for the exergy analysis

495

496 Exergy as a thermodynamic notion means the maximum work extracted from a stream as  
 497 the stream reaches the dead state [Bejan, 1988]. The total exergy of a system  $Ex$  includes four  
 498 components, namely physical exergy, kinetic exergy, potential exergy and chemical exergy [Rosen  
 499 2003]. Neglecting the potential and kinetic exergy changes, the exergy balance of different  
 500 components may be modelled as follows.

501

- 502 • *Turbine or pump*

503

$$\dot{l} = mT_0 \cdot \Delta s \quad (33)$$

$$\varepsilon = 1 - \dot{l}/(\dot{E}x_{in} + m\Delta h) \quad (34)$$

504

- *Heat exchanger*

506

$$\dot{l} = -(\Delta\dot{E}x_{hot} + \Delta\dot{E}x_{cold}) \quad (35)$$

$$\varepsilon = 1 - \dot{l}/(\dot{E}x_{hot_{in}} + \dot{E}x_{cold_{in}}) \quad (36)$$

507

- *Steam generator or condenser*

509

$$\dot{l} = mT_0\Delta s + \frac{T_0}{T}Q \quad (37)$$

$$\varepsilon = 1 - \dot{l}/\dot{E}x_{in} \quad (38)$$

510

- *TCS reactor*

512

$$\dot{l}_R = \sum \dot{E}x_{in_{tot}} - \sum \dot{E}x_{out_{tot}} - \left( \sum \dot{l}_{tot} - \dot{l}_R \right) \quad (39)$$

513

514 Where  $h$  (J·kg<sup>-1</sup>) is the specific enthalpy,  $\dot{E}x$  (W) the exergy and  $s$  (J·K<sup>-1</sup>·kg<sup>-1</sup>) the specific  
 515 entropy.  $\dot{l}$  (W) is the exergy destruction of the component and  $\varepsilon$  is the exergy efficiency of the  
 516 component. The overall exergy efficiency of the CSP plant  $\eta_{ex}$  is defined as the ratio of the exergy  
 517 extracted by turbine(s) to the amount of exergy provided by the HTF of the solar circuit.

518

$$\eta_{ex} = \frac{\sum \dot{E}x_{out}}{\sum \dot{E}x_{in}} \quad (40)$$

519

520

## 5.2. Results and discussion

522

523 An exergy analysis has been performed for the three proposed integration concepts. Figure  
 524 11 shows the exergy flow-chart for each integration concept comprising of both the charging and  
 525 the discharging stages. Note that the reference temperature  $T_0$  was chosen as 5 °C, a value lower  
 526 than those of the whole system. It allows an easier reading and interpretation of the results obtained.

527

528 The exergy flow-chart for the Thermal Int. concept is shown in Fig. 11a, indicating that the  
 529 overall exergy efficiency ( $\eta_{ex}$ ) equals to 0.49. It can be observed that the highest exergy destructions  
 530 happen in the TCS reactor and in the heat exchanger (HX2) during discharging whereas in the steam  
 531 generator, in the TCS reactor and in the condenser (CON2) during charging. These exergy  
 532 destructions are mainly due to the irreversibilities caused by the large amount of heat transfer in  
 533 these components. Note that exergy destructions in the reservoir and in pumps are negligible. A  
 534 close look at each component indicates that the CON2 with a very low exergy efficiency ( $\varepsilon_{CON2}=0.19$ )  
 535 during charging stage is the main cause of exergy destruction.

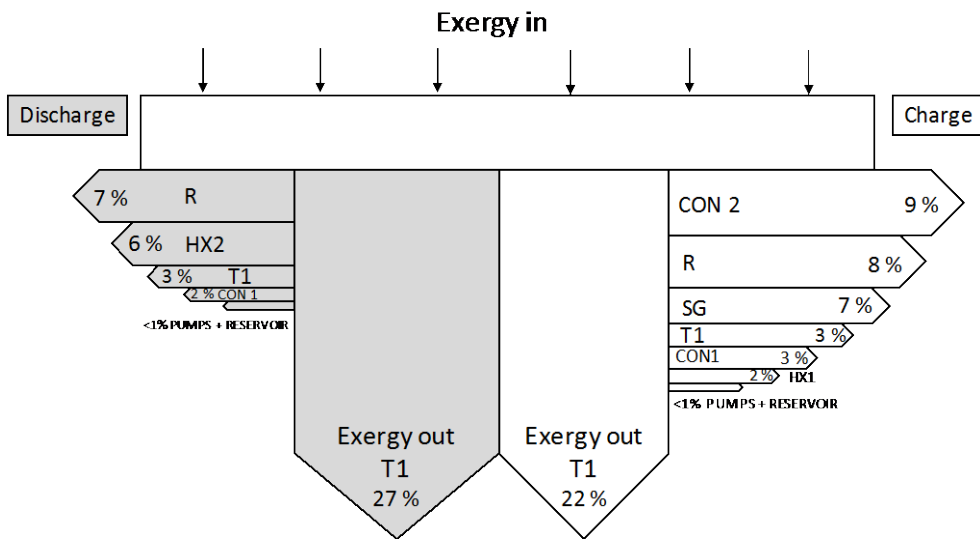

537

538

(a)

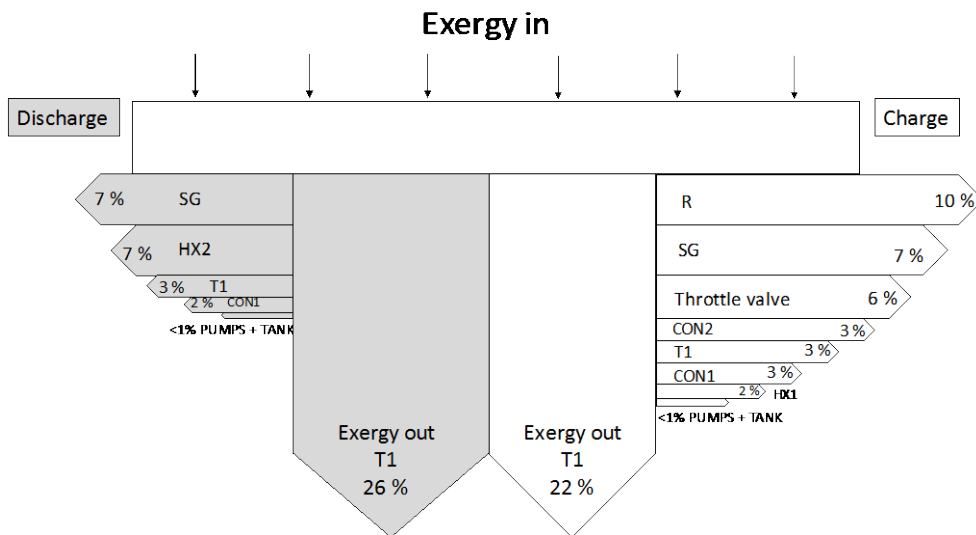

539

540

(b)

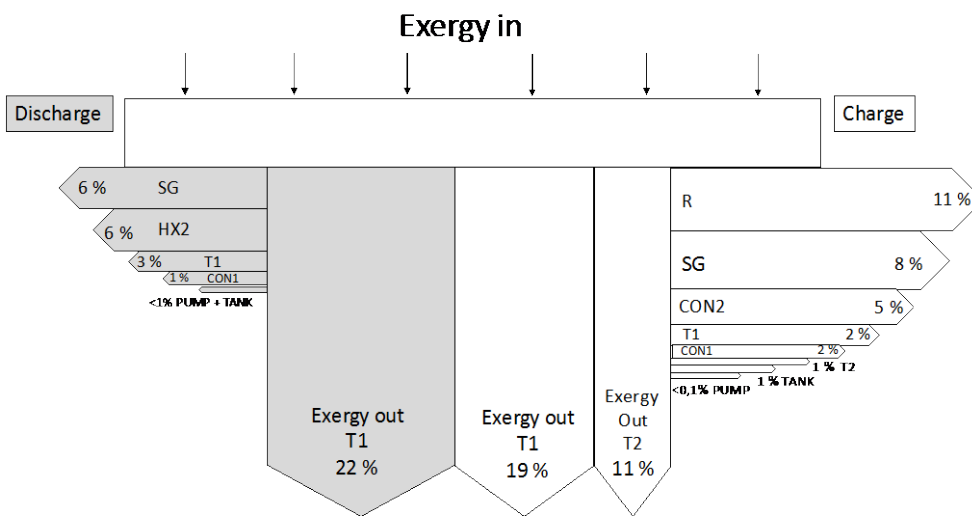

541

542

543

(c)

Figure 11. Exergy flow-chart and overall exergy efficiency ( $\eta_{ex}$ ) for three proposed integration concepts. (a) Thermal integration concept; (b) Mass integration concept; (c) Turbine integration concept.

544

545 The Mass Int. concept has a slightly lower  $\eta_{ex}$  value (0.48). It can be observed from Fig. 11b  
546 that the TCS reactor is the main component of exergy destruction during charging and discharging.  
547 The HX2 during discharging, the SG and throttle valve (TV) during charging also have high exergy  
548 destructions compared to those in reservoirs or pumps. Similar to the Thermal Int. concept, these  
549 losses are mainly due to the irreversibilities caused by the large amount of heat transfer in these  
550 components. An option to improve the  $\varepsilon_{TV}$  is to release the fluid at a pressure higher than 0.008  
551 MPa. Nevertheless, the condensed water should be stored separately instead of sharing a common  
552 reservoir which is the distinguishing feature of the Mass Int. concept.

553

554 The Turbine Int. concept has the highest exergy efficiency ( $\eta_{ex}=0.52$ ) among the three.  
555 Figure 11c indicates that the highest exergy destructions happen in the TCS reactor and in the HX2  
556 during discharging whereas in the TCS reactor, in the SG and in the CON2 during charging. The  
557 TCS reactor represents the highest exergy destruction of the system while the CON2 has the lowest  
558 exergy efficiency ( $\varepsilon_{CON2}=0.27$ ).

559

560 In brief, the exergy analysis of the three proposed integration concepts confirms that, in  
561 terms of overall exergy efficiency of the installation, the Turbine Int. concept is the most attractive  
562 ( $\eta_{ex}=0.52$ ), followed by the Thermal Int. concept ( $\eta_{ex}=0.49$ ) and then the Mass Int. concept  
563 ( $\eta_{ex}=0.48$ ).

564

565

## 566 **6. Conclusion and prospects**

567

568 This paper presents a conceptual study of three different TCS integration concepts in a  
569 Rankine cycle driven by CSP. The TCS material used in this study is the CaO/Ca(OH)<sub>2</sub> couple. Based  
570 on the energy and exergy analyses, main conclusions could be reached as follows.

571

572 • Different integration concepts are feasible by coupling the TCS system with a Rankine cycle  
573 and by carefully determining flow circuit configurations and working conditions for  
574 charging and discharging stages.

575

576 • The overall energy efficiency of the installation under ideal conditions is evaluated to be  
577 0.358 for the Thermal Int. concept, 0.349 for the Mass Int. concept and 0.392 for the Turbine  
578 Int. concept, respectively ( $H_C=11$ ;  $H_D=13$ ). Compared to the reference case without storage,  
579 the TCS integration decreases the overall energy efficiency but improves the adaptability  
580 and dispatchability of CSP plants with the increased power production.

581

582 • The energy storage density using calcium hydroxide as storage media is roughly estimated  
583 to be about 100 kWh<sub>el</sub>·t<sup>-1</sup>; this value is about seven times higher than that of existing CSP  
584 plant with a sensible heat storage using molten salt (about 13.1 kWh<sub>el</sub>·t<sup>-1</sup>).

585



- 586 • Different types of losses would cause a reduced overall energy efficiency of the installation.  
 587 Non-isentropic compression/expansion and poor efficiency of the TCS reactor would have  
 588 significant negative impacts on the overall energy efficiency.  
 589
- 590 • Among the three proposed integration concepts, the Turbine Int. concept seems to be the  
 591 best option with the highest overall energy and exergy efficiencies under the tested  
 592 conditions.  
 593

594 It should be noted that this study has focused on the integration conception issue, and  
 595 promising findings have been obtained for this essential step. Nevertheless, a number of scientific &  
 596 technological barriers remain to be overcome for the real implementation of TCS systems in CSP  
 597 plants. Our ongoing work includes the dynamic simulation of each individual components (including  
 598 the solar receiver and the TCS reactor) and the whole installation under real conditions. The techno-  
 599 economic considerations in TCS evaluation are also our study focus, so as to assess the feasibility of  
 600 such TCS integration into a real CSP plant. The results obtained on these remaining issues will be  
 601 presented in future papers.  
 602  
 603  
 604

## 605 **Acknowledgement**

606

607 This work was supported by the French ANR within the project In-STORES (ANR-12-  
 608 SEED-0008). The authors also wish to thank the colleagues of laboratory PROMES (CNRS UPR  
 609 8521) also involved in this ANR project, for fruitful and inspiring discussions.  
 610  
 611  
 612

## 613 **Nomenclature**

614

### 615 *Latin letters*

616	$\dot{E}x$	exergy, W
617	$H$	charging or discharging time, h
618	$h$	specific enthalpy, $\text{kJ}\cdot\text{kg}^{-1}$
619	$\dot{l}$	exergy destruction, W
620	$m$	mass flowrate, $\text{kg}\cdot\text{s}^{-1}$
621	$n$	number of mole
622	$P$	pressure, Pa
623	$Q$	heat exchange rate, W
624	$s$	specific entropy, $\text{kJ}\cdot\text{kg}^{-1}\cdot\text{K}^{-1}$
625	$T$	temperature, $^{\circ}\text{C}$
626	$T_0$	reference temperature, $5^{\circ}\text{C}$
627	$W$	work exchange rate, W
628	$x$	mass fraction of vapor

629	$y$	fraction of extracted steam
630	$X, Y$	intermediate points for the modeling of HX1
631		
632		
633	<i>Greek symbols</i>	
634	$\gamma$	global reactor efficiency
635	$\varepsilon$	exergy efficiency of component
636	$\Delta h_R$	reaction heat, $\text{kJ}\cdot\text{kg}^{-1}$
637	$\eta_o$	overall energy efficiency
638	$\eta_{isen}$	isentropic efficiency of turbine and pumps
639	$\eta_{ex}$	overall exergy efficiency
640		
641		
642	<i>Subscripts/superscripts</i>	
643	C	charging stage
644	D	discharging stage
645	el	electricity
646	ext	extraction
647	in	inlet
648	isen	isentropic
649	out	outlet
650	steam	steam
651	th	thermal
652	tot	total
653		
654		
655	<i>Abbreviation</i>	
656	CON	condenser
657	CSP	concentrating solar power
658	FH	feedwater heater
659	HTF	heat transfer fluid
660	HX	heat exchanger
661	Int.	integration
662	P	pump
663	PCM	phase change material
664	R	reactor
665	Rankine	Rankine circuit
666	SG	steam generator
667	T	turbine
668	TCS	thermochemical energy storage
669	TES	thermal energy storage
670	TV	throttle valve
671	WS	water reservoir

672 **References**

- 673  
674 Alva, G., Lin, Y., & Fang, G. (2018). An overview of thermal energy storage systems. *Energy*, 144, 341-378.  
675 <https://doi.org/10.1016/j.energy.2017.12.037>  
676  
677 Álvarez De Miguel, S., Gonzalez-Aguilar, J., & Romero, M. (2013). 100-Wh multi-purpose particle reactor for  
678 thermochemical heat storage in concentrating solar power plants. *Energy Procedia*, 49, 676–683.  
679 <https://doi.org/10.1016/j.egypro.2014.03.073>  
680  
681 André, L., Abanades, S., & Flamant, G. (2016). Screening of thermochemical systems based on solid-gas reversible  
682 reactions for high temperature solar thermal energy storage. *Renewable and Sustainable Energy Reviews*, 64,  
683 703-715. <https://doi.org/10.1016/j.rser.2016.06.043>  
684  
685 Aydin, D., Casey, S. P., & Riffat, S. (2015). The latest advancements on thermochemical heat storage systems.  
686 *Renewable and Sustainable Energy Reviews*, 41, 356–367. <https://doi.org/10.1016/j.rser.2014.08.054>  
687  
688 Azpiazu, M. N., Morquillas, J. M., & Vazquez, A. (2003). Heat recovery from a thermal energy storage based on  
689 the Ca(OH)<sub>2</sub>/CaO cycle. *Applied Thermal Engineering*, 23, 733–741. [https://doi.org/10.1016/S1359-4311\(03\)00015-2](https://doi.org/10.1016/S1359-4311(03)00015-2)  
690  
691 Bagherisereshki, E., Tran, J., Lei, F., AuYeung, N. (2018). Investigation into SrO/SrCO<sub>3</sub> for high temperature  
692 thermochemical energy storage. *Solar Energy*, 160, 85-93. <https://doi.org/10.1016/j.solener.2017.11.073>  
693  
694 Balghouthi, M., Trabelsi, S. E., Amara, M. B., Ali, A. B. H., & Guizani, A. (2016). Potential of concentrating solar  
695 power (CSP) technology in Tunisia and the possibility of interconnection with Europe. *Renewable and*  
696 *Sustainable Energy Reviews*, 56, 1227-1248. <https://doi.org/10.1016/j.rser.2015.12.052>  
697  
698 Bejan, A. (1988). *Advanced Engineering Thermodynamics*, John Wiley & Sons Inc., New York.  
699  
700 Cabeza, L. F., Gutierrez, A., Barreneche, C., Ushak, S., Fernández, Á. G., Inés Fernández, A., & Grágeda, M. (2015).  
701 Lithium in thermal energy storage: A state-of-the-art review. *Renewable and Sustainable Energy Reviews*, 42,  
702 1106–1112. <https://doi.org/10.1016/j.rser.2014.10.096>  
703  
704 Cabeza, L. F., Solé, A., Fontanet, X., Barreneche, C., Jové, A., Gallas, M., Fernández, A. I. (2017). Thermochemical  
705 energy storage by consecutive reactions for higher efficient concentrated solar power plants (CSP): Proof  
706 of concept. *Applied Energy*, 185, 836–845. <https://doi.org/10.1016/j.apenergy.2016.10.093>  
707  
708 Cáceres, G., Anrique, N., Girard, A., Degreève, J., Baeyens, J., & Zhang, H. L. (2013). Performance of molten salt  
709 solar power towers in Chile. *Journal of Renewable and Sustainable Energy*, 5(5).  
710 <https://doi.org/10.1063/1.4826883>  
711  
712 Calderón, A., Palacios, A., Barreneche, C., Segarra, M., Prieto, C., Rodriguez-Sanchez, A., & Fernández, A. I.  
713 (2018). High temperature systems using solid particles as TES and HTF material: A review. *Applied Energy*,  
714 213, 100-111. <https://doi.org/10.1016/j.apenergy.2017.12.107>  
715  
716 Chase, M. W. Jr. (1998). *NIST-JANAF Thermochemical Tables, Fourth Edition*. Journal of Physical and Chemical  
717 Reference Data.  
718  
719 Chirino, H., Xu, B., Xu, X., & Guo, P. (2018). Generalized diagrams of energy storage efficiency for latent heat  
720 thermal storage system in concentrated solar power plant. *Applied Thermal Engineering*, 129, 1595–1603.  
721 <https://doi.org/10.1016/j.applthermaleng.2017.10.153>  
722  
723 del Río, P., Peñasco, C., & Mir-Artigues, P. (2018). An overview of drivers and barriers to concentrated solar  
724 power in the European Union. *Renewable and Sustainable Energy Reviews*, 81, 1019-1029.  
725 <https://doi.org/10.1016/j.rser.2017.06.038>  
726  
727 Deutsch, M., Horvath, F., Knoll, C., Lager, D., Gierl-Mayer, C., Weinberger, P., & Winter, F. (2017). High-  
728 Temperature Energy Storage: Kinetic Investigations of the CuO/Cu<sub>2</sub>O Reaction Cycle. *Energy & Fuels*,  
729 31(3), 2324–2334. <https://doi.org/10.1021/acs.energyfuels.6b02343>  
730

731  
732 Dincer, I. (2002). Thermal energy storage systems as a key technology in energy conservation. *International Journal*  
733 *of Energy Research*, 26(7), 567–588. <https://doi.org/10.1002/er.805>  
734  
735 Dowling, A. W., Zheng, T., & Zavala, V. M. (2017). Economic assessment of concentrated solar power  
736 technologies: A review. *Renewable and Sustainable Energy Reviews*, 72, 1019-1032.  
737 <https://doi.org/10.1016/j.rser.2017.01.006>  
738  
739 Dunham, M. T., & Iverson, B. D. (2014). High-efficiency thermodynamic power cycles for concentrated solar  
740 power systems. *Renewable and Sustainable Energy Reviews*, 30, 758–770.  
741 <https://doi.org/10.1016/j.rser.2013.11.010>  
742  
743 Dunn, R. I., Hearps, P. J., & Wright, M. N. (2012). Molten-salt power towers: Newly commercial concentrating  
744 solar storage. In *Proceedings of the IEEE* (Vol. 100, pp. 504–515).  
745 <https://doi.org/10.1109/JPROC.2011.2163739>  
746  
747 Fernandes, D., Pitié, F., Cáceres, G., & Baeyens, J. (2012). Thermal energy storage: “How previous findings  
748 determine current research priorities.” *Energy*, 39(1), 246–257. <https://doi.org/10.1016/j.energy.2012.01.024>  
749  
750 Gil, A., Medrano, M., Martorell, I., Lázaro, A., Dolado, P., Zalba, B., & Cabeza, L. F. (2010). State of the art on  
751 high temperature thermal energy storage for power generation. Part I-Concepts, materials and  
752 modellization. *Renewable and Sustainable Energy Reviews*, 14, 31-55. <https://doi.org/10.1016/j.rser.2009.07.035>  
753  
754 Gutierrez, A., Miró, L., Gil, A., Rodríguez-Aseguinolaza, J., Barreneche, C., Calvet, N., Cabeza, L. F. (2016).  
755 Advances in the valorization of waste and by-product materials as thermal energy storage (TES) materials.  
756 *Renewable and Sustainable Energy Reviews*, 59, 763–783. <https://doi.org/10.1016/j.rser.2015.12.071>  
757  
758 IEA (2014). Energy Technology Perspectives. Paris, France: IEA publications; <http://www.iea.org/etp/etp2014/>.  
759  
760 IRENA (2016). REmap: roadmap for a renewable energy future, 2016 edition. Abu Dhabi: International Renewable  
761 Energy Agency (IRENA); ([www.irena.org/remap](http://www.irena.org/remap)).  
762  
763 Kang, Q., Dewil, R., Degève, J., Baeyens, J., Zhang, H. (2018). Energy analysis of a particle suspension solar  
764 combined cycle power plant. *Energy Conversion and Management*, 163, 293-303.  
765 <https://doi.org/10.1016/j.enconman.2018.02.067>  
766  
767 Kuravi, S., Trahan, J., Goswami, D. Y., Rahman, M. M., & Stefanakos, E. K. (2013). Thermal energy storage  
768 technologies and systems for concentrating solar power plants. *Progress in Energy and Combustion Science*,  
769 39, 285-319. <https://doi.org/10.1016/j.pecs.2013.02.001>  
770  
771 Liu, M., Steven Tay, N. H., Bell, S., Belusko, M., Jacob, R., Will, G., Saman, W., Bruno, F. (2016). Review on  
772 concentrating solar power plants and new developments in high temperature thermal energy storage  
773 technologies. *Renewable and Sustainable Energy Reviews*, 53, 1411-1432.  
774 <https://doi.org/10.1016/j.rser.2015.09.026>  
775  
776 Luo, L., Fan Y., Mazet, N., Stitou, D., Mauran, S., Neveu, P. (2016). Installation de production d'électricité  
777 comprenant un stockage de chaleur. French Patent FR 16 62785  
778  
779 Michel, B., Mazet, N., Mauran, S., Stitou, D., & Xu, J. (2012). Thermochemical process for seasonal storage of  
780 solar energy: Characterization and modeling of a high density reactive bed. *Energy*, 47, 553–563.  
781 <https://doi.org/10.1016/j.energy.2012.09.029>  
782  
783 Moran, M.J., Shapiro, H.N., Munson, B.R., DeWitt, D.P., (2003). *Introduction to Thermal Systems Engineering:*  
784 *Thermodynamics, Fluid Mechanics and Heat Transfer*. John Wiley & Sons, Inc.  
785  
786 Myers, P. D., & Goswami, D. Y. (2016). Thermal energy storage using chloride salts and their eutectics. *Applied*  
787 *Thermal Engineering*, 109, 889–900. <https://doi.org/10.1016/j.applthermaleng.2016.07.046>  
788

789 Nithyanandam, K., & Pitchumani, R. (2014). Cost and performance analysis of concentrating solar power systems  
790 with integrated latent thermal energy storage. *Energy*, 64, 793–810.  
791 <https://doi.org/10.1016/j.energy.2013.10.095>  
792

793 Ortega-Fernández, I., Calvet, N., Gil, A., Rodríguez-Aseguinolaza, J., Faik, A., & D'Aguzzo, B. (2015).  
794 Thermophysical characterization of a by-product from the steel industry to be used as a sustainable and  
795 low-cost thermal energy storage material. *Energy*, 89, 601–609. <https://doi.org/10.1016/j.energy.2015.05.153>  
796

797 Ortiz, C., Chacartegui, R., Valverde, J. M., Alovio, A., & Becerra, J. A. (2017). Power cycles integration in  
798 concentrated solar power plants with energy storage based on calcium looping. *Energy Conversion and*  
799 *Management*, 149, 815–829. <https://doi.org/10.1016/j.enconman.2017.03.029>  
800

801 Pan, Z. H., & Zhao, C. Y. (2017). Gas–solid thermochemical heat storage reactors for high-temperature  
802 applications. *Energy*, 130, 155–173. <https://doi.org/10.1016/j.energy.2017.04.102>  
803

804 Parrado, C., Cáceres, G., Bize, F., Bubnovich, V., Baeyens, J., Degève, J., & Zhang, H. L. (2015). Thermo-  
805 mechanical analysis of copper-encapsulated NaNO<sub>3</sub>-KNO<sub>3</sub>. *Chemical Engineering Research and Design*, 93,  
806 224–231. <https://doi.org/10.1016/j.cherd.2014.07.007>  
807

808 Pardo, P., Anxionnaz-Minvielle, Z., Rougé, S., Cognet, P., & Cabassud, M. (2014). Ca(OH)<sub>2</sub>/CaO reversible  
809 reaction in a fluidized bed reactor for thermochemical heat storage. *Solar Energy*, 107, 605–616.  
810 <https://doi.org/10.1016/j.solener.2014.06.010>  
811

812 Pardo, P., Deydier, A., Anxionnaz-Minvielle, Z., Rougé, S., Cabassud, M., & Cognet, P. (2014). A review on high  
813 temperature thermochemical heat energy storage. *Renewable and Sustainable Energy Reviews*, 32, 591–610  
814 <https://doi.org/10.1016/j.rser.2013.12.014>  
815

816 Pelay, U., Luo, L., Fan, Y., Stitou, D., & Rood, M. (2017a). Thermal energy storage systems for concentrated solar  
817 power plants. *Renewable and Sustainable Energy Reviews*, 79, 82–100.  
818 <https://doi.org/10.1016/j.rser.2017.03.139>  
819

820 Pelay, U., Luo, L., Fan, Y., Stitou, D., & Rood, M. (2017b). Technical data for concentrated solar power plants in  
821 operation, under construction and in project. *Data in Brief*, 13, 597–599.  
822 <https://doi.org/10.1016/j.dib.2017.06.030>  
823

824 Pitié, F., Zhao, C. Y., Baeyens, J., Degève, J., & Zhang, H. L. (2013). Circulating fluidized bed heat recovery/storage  
825 and its potential to use coated phase-change-material (PCM) particles. *Applied Energy*, 109, 505–513.  
826 <https://doi.org/10.1016/j.apenergy.2012.12.048>  
827

828 Prieto, C., Cooper, P., Fernández, A. I., & Cabeza, L. F. (2016). Review of technology: Thermochemical energy  
829 storage for concentrated solar power plants. *Renewable and Sustainable Energy Reviews*, 60, 909–929.  
830 <https://doi.org/10.1016/j.rser.2015.12.364>  
831

832 Rosen, M. A., & Dincer, I. (2003). Exergy methods for assessing and comparing thermal storage systems.  
833 *International Journal of Energy Research*, 27(4), 415–430. <https://doi.org/10.1002/er.885>  
834

835 Sakellariou, K. G., Criado, Y. A., Tsongidis, N. I., Karagiannakis, G., & Konstandopoulos, A. G. (2017). Multi-cyclic  
836 evaluation of composite CaO-based structured bodies for thermochemical heat storage via the  
837 CaO/Ca(OH)<sub>2</sub> reaction scheme. *Solar Energy*, 146, 65–78. <https://doi.org/10.1016/j.solener.2017.02.013>  
838

839 Schaube, F., Koch, L., Wörner, A., & Müller-Steinhagen, H. (2012). A thermodynamic and kinetic study of the de-  
840 and rehydration of Ca(OH)<sub>2</sub> at high H<sub>2</sub>O partial pressures for thermo-chemical heat storage. *Thermochimica*  
841 *Acta*, 538, 9–20. <https://doi.org/10.1016/j.tca.2012.03.003>  
842

843 Schaube, F., Utz, I., Wörner, A., & Müller-Steinhagen, H. (2013a). De- and rehydration of Ca(OH)<sub>2</sub> in a reactor  
844 with direct heat transfer for thermo-chemical heat storage. Part A: Experimental results. *Chemical*  
845 *Engineering Research and Design*, 91, 856–864. <https://doi.org/10.1016/j.cherd.2012.09.020>  
846

847 Schaubé, F., Utz, I., Wörner, A., & Müller-Steinhagen, H. (2013b). De- and rehydration of Ca(OH)<sub>2</sub> in a reactor  
848 with direct heat transfer for thermo-chemical heat storage. Part B: Validation of model. *Chemical Engineering*  
849 *Research and Design*, 91, 865–873. <https://doi.org/10.1016/j.cherd.2013.02.019>  
850

851 Schaubé, F., Wörner, A., & Tamme, R. (2011). High temperature thermochemical heat storage for concentrated  
852 solar power using gas–solid reactions. *Journal of Solar Energy Engineering*, 133, 031006.  
853 <https://doi.org/10.1115/1.4004245>  
854

855 Schmidt, M., Gutierrez, A., & Linder, M. (2017). Thermochemical energy storage with CaO/Ca(OH)<sub>2</sub>–  
856 Experimental investigation of the thermal capability at low vapor pressures in a lab scale reactor. *Applied*  
857 *Energy*, 188, 672–681. <https://doi.org/10.1016/j.apenergy.2016.11.023>  
858

859 Schmidt, M., & Linder, M. (2017). Power generation based on the Ca(OH)<sub>2</sub>/ CaO thermochemical storage system  
860 – Experimental investigation of discharge operation modes in lab scale and corresponding conceptual  
861 process design. *Applied Energy*, 203, 594–607. <https://doi.org/10.1016/j.apenergy.2017.06.063>  
862

863 Sharma, R. K., Ganesan, P., Tyagi, V. V., Metselaar, H. S. C., & Sandaran, S. C. (2015). Developments in organic  
864 solid-liquid phase change materials and their applications in thermal energy storage. *Energy Conversion and*  
865 *Management*, 95, 193–228. <https://doi.org/10.1016/j.enconman.2015.01.084>  
866

867 Smolders, K., & Baeyens, J. (2000). Cleaning of hot calciner exhaust gas by low-density ceramic filters. *Powder*  
868 *Technology*, 111(3), 240–244. [https://doi.org/10.1016/S0032-5910\(99\)00291-0](https://doi.org/10.1016/S0032-5910(99)00291-0)  
869

870 Tescari, S., Singh, A., De Oliveira, L., Breuer, S., Agrafiotis, C., Roeb, M., Sattler, C., Marcher, J., Pagkoura, C.,  
871 Karagiannakis, G., Konstandopoulos, A. G. (2017). Experimental proof of concept of a pilot-scale  
872 thermochemical storage unit. In *AIP Conference Proceedings* (Vol. 1850). American Institute of Physics Inc.  
873 <https://doi.org/10.1063/1.4984455>  
874

875 Tescari, S., Singh, A., Agrafiotis, C., de Oliveira, L., Breuer, S., Schlögl-Knothe, B., Roeb, M., Sattler, C. (2017).  
876 Experimental evaluation of a pilot-scale thermochemical storage system for a concentrated solar power  
877 plant. *Applied Energy*, 189, 66–75. <https://doi.org/10.1016/j.apenergy.2016.12.032>  
878

879 Tian, Y., & Zhao, C. Y. (2013). A review of solar collectors and thermal energy storage in solar thermal  
880 applications. *Applied Energy*, 104, 538–553. <https://doi.org/10.1016/j.apenergy.2012.11.051>  
881

882 Tiskatine, R., Aharoune, A., Bouirden, L., & Ihlal, A. (2017). Identification of suitable storage materials for solar  
883 thermal power plant using selection methodology. *Applied Thermal Engineering*, 117, 591–608.  
884 <https://doi.org/10.1016/j.applthermaleng.2017.01.107>  
885

886 Valverde, J. M., Barea-López, M., Perejón, A., Sánchez-Jiménez, P. E., & Pérez-Maqueda, L. A. (2017). Effect of  
887 thermal pretreatment and nanosilica addition on limestone performance at calcium-looping conditions for  
888 thermochemical energy storage of concentrated solar power. *Energy and Fuels*, 31(4), 4226–4236.  
889 <https://doi.org/10.1021/acs.energyfuels.6b03364>  
890

891 Wokon, M., Kohzer, A., & Linder, M. (2017). Investigations on thermochemical energy storage based on technical  
892 grade manganese-iron oxide in a lab-scale packed bed reactor. *Solar Energy*, 153, 200–214.  
893 <https://doi.org/10.1016/j.solener.2017.05.034>  
894

895 Xu, B., Li, P., & Chan, C. (2015). Application of phase change materials for thermal energy storage in concentrated  
896 solar thermal power plants: A review to recent developments. *Applied Energy*, 160, 286–307.  
897 <https://doi.org/10.1016/j.apenergy.2015.09.016>  
898

899 Yan, J., & Zhao, C. Y. (2016). Experimental study of CaO/Ca(OH)<sub>2</sub> in a fixed-bed reactor for thermochemical  
900 heat storage. *Applied Energy*, 175, 277–284. <https://doi.org/10.1016/j.apenergy.2016.05.038>  
901

902 Yan, J., Zhao, C. Y., & Pan, Z. H. (2017). The effect of CO<sub>2</sub> on Ca(OH)<sub>2</sub> and Mg(OH)<sub>2</sub> thermochemical heat  
903 storage systems. *Energy*, 124, 114–123. <https://doi.org/10.1016/j.energy.2017.02.034>  
904

905 Zhang, H. L., Baeyens, J., Degrève, J., Cáceres, G., Segal, R., & Pitié, F. (2014). Latent heat storage with tubular-  
906 encapsulated phase change materials (PCMs). *Energy*, 76, 66–72.  
907 <https://doi.org/10.1016/j.energy.2014.03.067>  
908

909 Zhang, H. L., Baeyens, J., Degrève, J., & Cáceres, G. (2013). Concentrated solar power plants: Review and design  
910 methodology. *Renewable and Sustainable Energy Reviews*, 22, 466–481.  
911 <https://doi.org/10.1016/j.rser.2013.01.032>  
912

913 Zhang, H., Baeyens, J., Cáceres, G., Degrève, J., & Lv, Y. (2016). Thermal energy storage: Recent developments  
914 and practical aspects. *Progress in Energy and Combustion Science*, 53, 1–40.  
915 <https://doi.org/10.1016/j.pecs.2015.10.003>  
916

917 Zhang, H., Benoit, H., Perez-López, I., Flamant, G., Tan, T., & Baeyens, J. (2017). High-efficiency solar  
918 power towers using particle suspensions as heat carrier in the receiver and in the thermal energy  
919 storage. *Renewable Energy*, 111, 438–446. <https://doi.org/10.1016/j.renene.2017.03.101>  
920

921 Zhang, H., Huys, K., Baeyens, J., Degrève, J., Kong, W., & Lv, Y. (2016). Thermochemical energy storage  
922 for power generation on demand. *Energy Technology*, 4(2), 341–352.  
923 <https://doi.org/10.1002/ente.201500261>

924 Zhang, H., Kong, W., Tan, T., & Baeyens, J. (2017b). High-efficiency concentrated solar power plants  
925 need appropriate materials for high-temperature heat capture, conveying and storage. *Energy*,  
926 139, 52–64. <https://doi.org/10.1016/j.energy.2017.07.129>  
927  
928  
929  
930