



**HAL**  
open science

## Specific TCP transcription factors interact with and stabilize PRR2 within different nuclear sub-domains

M. Perez, Y. Guerringue, B. Ranty, C. Pouzet, A. Jauneau, E. Robe,  
Christian Mazars, J.P. Galaud, D. Aldon

### ► To cite this version:

M. Perez, Y. Guerringue, B. Ranty, C. Pouzet, A. Jauneau, et al.. Specific TCP transcription factors interact with and stabilize PRR2 within different nuclear sub-domains. *Plant Science*, 2019, 287, pp.110197. 10.1016/j.plantsci.2019.110197 . hal-02358710

**HAL Id: hal-02358710**

**<https://hal.science/hal-02358710>**

Submitted on 12 Nov 2019

**HAL** is a multi-disciplinary open access archive for the deposit and dissemination of scientific research documents, whether they are published or not. The documents may come from teaching and research institutions in France or abroad, or from public or private research centers.

L'archive ouverte pluridisciplinaire **HAL**, est destinée au dépôt et à la diffusion de documents scientifiques de niveau recherche, publiés ou non, émanant des établissements d'enseignement et de recherche français ou étrangers, des laboratoires publics ou privés.

## TITLE PAGE

### TITLE :

**Specific TCP transcription factors interact with and stabilize PRR2 within different nuclear sub-domains**

### AUTHOR NAMES AND AFFILIATIONS

**Perez M.<sup>1,3</sup>, Guerringue Y.<sup>1,4</sup>, Ranty B.<sup>1</sup>, Pouzet C.<sup>2</sup>, Jauneau A.<sup>2</sup>, Robe E.<sup>1</sup>, Mazars C.<sup>1</sup>, Galaud J.P.<sup>1</sup>, Aldon D.<sup>1\*</sup>**

<sup>1</sup> Laboratoire de Recherche en Sciences Végétales, Université de Toulouse, CNRS, UPS, 24 chemin de Borde Rouge, Auzeville, BP42617, 31326 Castanet-Tolosan, France.

<sup>2</sup> Fédération de Recherche FR3450 (Agrobiosciences, Interactions et Biodiversité), Plateforme Imagerie-Microscopie, CNRS, Université Toulouse, 31326, Castanet-Tolosan, France.

<sup>3</sup> Toulouse NeuroImaging Center, INSERM, UPS, Pavillon Baudot, CHU Purpan, Place du Dr Baylac, 31024 Toulouse, France

<sup>4</sup> Institute for Integrative Biology of the Cell (I2BC), CEA, CNRS, Univ. Paris-Sud, Université Paris-Saclay, Gif-sur-Yvette cedex, France

manon.perez@inserm.fr; yannick.guerringue@i2bc.paris-saclay.fr; ranty@lrsv.ups-tlse.fr; pouzet@lrsv.ups-tlse.fr; jauneau@lrsv.ups-tlse.fr; eugenie.robe@lrsv.ups-tlse.fr; mazars@lrsv.ups-tlse.fr; galaud@lrsv.ups-tlse.fr; aldon@lrsv.ups-tlse.fr.

### CORRESPONDING AUTHOR

\* Corresponding author = Aldon D (aldon@lrsv.ups-tlse.fr)

Phone number = 33 5 34 32 38 02

**DECLARATIONS OF INTEREST:** None

**DATE OF SUBMISSION :** 12- 04- 2019

**NIMBER OF TABLES AND FIGURES:** 1 table and 5 figures

**TITLE: Specific TCP transcription factors interact with and stabilize PRR2 within different nuclear sub-domains**

**HIGHLIGHTS**

- PRR2 interacts with TCPs from class I and II
- TCP19 and 20 control PRR2 protein stability
- These TCP mobilize the complex in particular nuclear subdomains.

**ABSTRACT** 198 words

Plants possess a large set of transcription factors both involved in the control of plant development or in plant stress responses coordination. We previously identified PRR2, a Pseudo-Response Regulator, as a plant-specific CML-interacting partner. We reported that PRR2 acts as a positive actor of plant defense by regulating the production of antimicrobial compounds. Here, we report new data on the interaction between PRR2 and transcription factors belonging to the *Teosinte branched Cycloidea and PCF* (TCP) family. TCPs have been described to be involved in plant development and immunity. We evaluated the ability of PRR2 to interact with seven TCPs representative of the different subclades of the family. PRR2 is able to interact with TCP13, TCP15, TCP19 and TCP20 in yeast two-hybrid system and *in planta* interactions were validated for TCP19 and TCP20. Transient expression in tobacco highlighted that PRR2 protein is more easily detected when co-expressed with TCP19 or TC20. This stabilization is associated with a specific sub-nuclear localization of the complex in Cajal bodies or in nuclear speckles according to the interaction of PRR2 with TCP19 or TCP20 respectively. The interaction between PRR2 and TCP19 or TCP20 would contribute to the biological function in specific nuclear compartments.

**KEYWORDS:** *Arabidopsis thaliana*, FRET-FLIM, Nuclear localization, Protein-protein interaction, Protein stabilization, Pseudo-Response Regulator, TCP, Transcription factor.

**ABBREVIATIONS:** ARR, Authentic Response Regulator; CML, Calmodulin-like protein; PRR, Pseudo-response Regulator.

## 1 1.1 INTRODUCTION

2 To cope with adverse conditions, plants have evolved adaptive processes which include  
3 complex cellular signaling pathways and a sophisticated regulatory machinery to govern  
4 biochemical and molecular changes [1]. Transcription factors (TFs) play crucial roles in these  
5 processes by regulating in a cell type-specific manner, the genetic reprogramming in a given  
6 organ or tissue [2]. To coordinate their activity at a spatio-temporal level, TFs are finely tuned  
7 thanks to diverse post-translational modifications and/or interactions with associated  
8 cofactors or proteins [3].

9 During the last decade, emerging data clearly indicate a link between Ca<sup>2+</sup> sensors, such as  
10 CaM (Calmodulin) or CPKs and the control of gene transcription [4, 5]. Thus, a novel family of  
11 CaM-binding transcription activators (CAMTAs) has been shown to contribute to plant  
12 immunity and to hormonal responses [6, 7]. Among these Ca<sup>2+</sup> signaling sensors, a protein  
13 family represented by the Calmodulin-like proteins (CML), which are plant specific, have been  
14 proposed to participate in diverse plant developmental processes and in stress responses [8].  
15 Interestingly two CMLs, CML8 and CML9, were described to contribute to plant immunity [9-  
16 11] and few years ago we identified PRR2 as one of their interacting partners in *A. thaliana*  
17 [12]. PRR2 is a plant specific TF belonging to the Pseudo-Response Regulator (PRR) family  
18 which is closely related to the Authentic Response Regulators (ARRs) involved in plant  
19 hormone perception [13-15]. Despite their structural similarity with ARR, PRRs are missing  
20 essential residues required for the phospho-accepting activity in the receiver domain whereas  
21 PRR2 exhibit other motifs and/or domains [16]. Indeed, PRR2 possesses a DNA-binding  
22 domain (GARP domain) and a conserved GCT box only encountered in GLKs (Golden2-Like)  
23 proteins that are plant specific transcription factors involved in chloroplast biogenesis [12, 17].  
24 Until recently, the role of PRR2 remained unknown. Using reverse genetic approaches in *A.*  
25 *thaliana*, we showed that PRR2 acts as a positive regulator of plant defense against the  
26 phytopathogenic bacteria, *Pseudomonas syringae* [18]. When over-expressed, under a  
27 constitutive 35S promoter (*35S promoter::PRR2*), PRR2 leads to an increase in the expression  
28 of plant defense markers gene such as *PR1* [18]. PRR2 enhances the SA accumulation and the  
29 production of antimicrobial compounds such as camalexin or callose in response to *P. syringae*  
30 [18]. Alternatively, Pan *et al.* (2013) showed that *SIPRR2*, the putative PRR2 orthologous in  
31 tomato, controls fruit pigmentation and ripening [19]. The *SIPRR2* overexpressing lines

32 possesses plastids with an enhanced size and higher chlorophyll content and accumulate more  
33 carotenoids in tomato fruits than the WT plants [19]. Collectively, these data support the  
34 hypothesis that PRR2 might exert different roles in plant physiology acting both in plant  
35 development and in plant immunity. The direct target genes and the molecular processes  
36 controlled by PRR2 remain unknown but experimental data clearly indicate that PRR2  
37 interacts with different protein partners [12, 20]. The study of the PRR2 interactome could  
38 help to better understand the PRR2 function at the molecular level and its biological relevance.  
39 Thus, the first map of the *A. thaliana* interactome fulfilled by the Arabidopsis Interactome  
40 Consortium reported that PRR2 interacts with TCP19 [20]. TCPs (standing for the first three  
41 identified members *TEOSINTE BRANCHED1*, *CYCLOIDEA* and *PROLIFERATING CELL FACTOR 1*  
42 and 2) are plant-specific TFs containing a conserved 59 amino acid basic helix–loop–helix  
43 (bHLH) motif called TCP domain [21, 22]. TCPs belong to a TF family encompassing 24  
44 members in *Arabidopsis thaliana* which are divided in 2 sub-groups (Class I and Class II CIN or  
45 Class II CYC) according to the conservation of the TCP DNA-binding domain and the presence  
46 or not of different patterns [23]. TCPs are involved in a wide diversity of developmental  
47 pathways in plants [23] and recently, it was described that some of these TCPs also contribute  
48 to plant immunity [24-26]. Thus, according to Weßling *et al.* (2014), TCPs (*i.e.* TCP13, TCP14,  
49 TCP15, TCP19 and TCP21) appear as targets for plant pathogen effectors [27]. Moreover, gene  
50 expression of other TCPs (TCP8, TCP9, TCP13 and TCP20) is rapidly induced in response to  
51 *Pseudomonas* inoculation and TCP8, 9, 15 and 20 were shown to regulate *ICS1* gene  
52 expression, a key enzyme of the SA biosynthesis pathway [28]. On the other hand, TCP8 and  
53 15 have also been shown to contribute to the control of plant growth in gibberellin-dependent  
54 pathways [29]. In the case of TCP9, TCP19 and 20, they have been shown to contribute to the  
55 control of leaf development and senescence [30, 31]. Thus like TCPs, PRR2 seems to have  
56 multiple roles being involved in different biological processes, likely depending on their  
57 partners interactions.

58 Here, we report the analysis of the interaction between PRR2 and seven TCPs from *A.*  
59 *thaliana* by yeast two-hybrid experiments. We both examined the specificity of the interaction  
60 between PRR2 and representative members of the different subclades of the TCP family, we  
61 explored the modalities of this interaction by identifying the domains of PRR2 protein that are  
62 required for these interactions. Using a FRET-FLIM approach, we demonstrate that PRR2

63 interacts *in planta* with some specific TCPs. The biological relevance of this crosstalk between  
64 TCPs and PRR2 is discussed since we bring evidence that TCPs might control PRR2 protein  
65 stability by stabilizing the PRR2-TCP complex in particular nuclear subdomains according to  
66 the identity of the PRR2-interacting TCP.

## 67 1.2 MATERIAL AND METHODS

### 68 1.2.1 Yeast two-hybrid assays

69 The cDNA clones of 7 *Arabidopsis* TCPs (TCP10, TCP12, TCP13, TCP14, TCP15, TCP19 and  
70 TCP20) were introduced into *pGAD* (AD-TCP) and *pGBG* (BD-TCP) vectors (derived from  
71 *pGADT7* and *pGBKT7* plasmids from Clontech) by the Gateway™ cloning technology  
72 (Invitrogen) as described by Perochon *et al.* (2010) [12]. All the constructs were checked by  
73 sequencing. For the other constructs used in this study (PRR2, PRR2 ( $\Delta$ 1-296), PRR2 ( $\Delta$ 297-535),  
74 CML9, ARR10), the plasmids were obtained from Perochon *et al.* (2010) [12].

75 The Gal4 yeast two-hybrid assays were conducted as previously described in Perochon *et al.*  
76 *al.*(2010) [12]. Briefly, the bait and prey plasmids were transformed *into the Saccharomyces*  
77 *cerevisiae* yeast strain AH109 by heat shock. The double transformed yeasts were selected on  
78 tryptophan (W) and leucine (L) drop-out medium (SD -WL) (Sigma) and then on  
79 Trp/Leu/His/Ade (-WLHA) drop-out medium supplemented or not by 3-AT to determine the  
80 expression of *HIS3* and *ADE2* reporter genes.

81

### 82 1.2.2 Subcellular localization and *in planta* protein-protein interaction assays

83 For *in planta* protein localizations assays, the ORFs of the TCP12, 19 and 20 were introduced  
84 by recombination in the *pAM-PAT-P35S-YFP-GW* or *pAM-PAT-P35S-GW-YFP* to give fusion  
85 proteins with YFP respectively at C- or N-terminus region. The PRR2-CFP fusion protein was  
86 obtained by introducing the corresponding cDNA in the *pAM-PAT-P35S-GW-CFP*. We also used  
87 marker proteins of nuclear compartments, SERRATE (RFP tagged) and Coiline 1 (YFP tagged)  
88 [32, 33].

89 The *Agrobacterium tumefaciens* strain GV3103 was transformed with the desired  
90 constructs by heat shock method. Then single colonies were grown on LB liquid culture  
91 medium with appropriate antibiotics during 24 hours. Bacteria were centrifuged and re-  
92 suspended in infiltration buffer (MES/KOH 10mM pH 5.7, 10mM MgCl<sub>2</sub>, 200 $\mu$ M  
93 Acetosyringone) (Sigma™) to reach an OD<sub>600nm</sub> = 0.5. The bacteria carrying the expression  
94 vector (CFP and/or YFP fusion proteins) were infiltrated for transient expression into 4-week-  
95 old *Nicotiana benthamiana* leaves. Equal volumes of transformed *A. tumefaciens* were used  
96 for co-expression and infiltrated plants were maintained for 48 hours in a growth chamber.



97 48h post-infiltration, the protein expression was examined by confocal or fluorescent  
98 microscopy. *Nicotiana benthamiana* plants used for agro-infiltrations experiments were  
99 grown in pots in controlled growth chambers (25°C, under long-day photoperiod 16h light/8h  
100 dark, humidity 60%) until four weeks after sowing.

101 CFP and YFP fluorescence for subnuclear localization was analyzed with a confocal laser  
102 scanning microscope (TCS SP8; Leica) using an x25 water immersion objective lens (numerical  
103 aperture 0.95; HCX PL APO CS2). CFP and YFP fluorescence was excited with the 458/514 nm  
104 ray line of the argon laser and recorded in one of the confocal channels in the 465 to 520/ 525  
105 to 575 nm emission range respectively. The images were acquired in the sequential mode  
106 using Leica LAS X software (version 3.0).

107 For the FRET-FLIM analyses, the fluorescence lifetime values were measured using  
108 multiphoton FLIM system. FRET efficiencies (E) were calculated for 30 individual objects of  
109 interest of at least two independent experiments (n=60) by comparing the mean lifetime of  
110 the donor ( $\tau_D$ ) and of the donor in the presence of the acceptor ( $\tau_{DA}$ ) ( $E = 1 - (\tau_{DA} / \tau_D)$ ).  
111 Nonlinear least squares analysis were used to fit the lifetime measurement data as described  
112 in Camborde *et al.* (2017) [34].

113

### 114 **1.2.3 Efficiency of PRR2-CFP expression in transformed tobacco cells: Quantitative** 115 **analyses**

116 To perform this analysis we used the constructs and the transient expression method as  
117 described above. The number of nuclei exhibiting CFP (PRR2-CFP) and/or YFP (TCP-YFP)  
118 emitted fluorescence in transformed or co-transformed leaf discs were quantified using a wide  
119 field microscope (Nikon Eclipse Ti) 48 hours after infiltration. CFP and YFP were respectively  
120 excited at 425-440 nm and 489-505 nm and the fluorescent emissions of CFP and YFP were  
121 detected at  $479 \text{ nm} \pm 20 \text{ nm}$  and at  $535 \pm 11.5 \text{ nm}$ . Three independent discs by plant were  
122 harvested and nine square fields of  $1173 \mu\text{m}$  side were acquired for data analyses on each  
123 disk. The number of CFP and/or YFP fluorescent nuclei were quantified on all the samples  
124 using ImageJ software and these data were analyzed for statistics.

125

126 **1.2.4 Accession Numbers**

127 PRR2 (AT4G18020), CML9 (AT3G51920), TCP10 (AT2G31070), TCP12 (AT1G68800), TCP13  
128 (AT3G02150), TCP14 (AT3G47620), TCP15 (AT1G69690), TCP19 (AT5G51910), TCP20  
129 (AT3G27010).

130 **1.2.5 Statistical analysis**

131 All the results obtained were analyzed using R software environment for statistical  
132 computing and graphics.

133

## 134 1.3 RESULTS

### 135 1.3.1 PRR2 interacts with plant specific transcription factors belonging to the TCP 136 family

137 To investigate the interaction between PRR2 and TCPs, we analyzed the ability of PRR2 to  
138 interact with seven different TCPs by yeast two-hybrid system. TCP10, 12, 13, 14, 15, 19 and  
139 TCP20 were selected as representatives of different class and subclades of the TCP family as  
140 described by Martin-Trillo and Cubas (2010) [23] (Figure 1A). As previously reported [12], PRR2  
141 does not exhibit auto-activation neither in the BD configuration (Figure 1B, first row) nor in  
142 the AD configuration (data not shown). The interaction between PRR2 and TCPs was evaluated  
143 with PRR2 associated to the GAL4 DNA-binding domain (BD-PRR2) and TCPs associated to the  
144 activation domain (AD-TCP). Yeasts co-transformed with BD-PRR2 and AD-TCP10, TCP12 or  
145 TCP14 did not grow on selective medium suggesting that these TCPs do not interact with PRR2  
146 (Figure 1B). BD-PRR2/AD-TCP13, TCP15 and AD-TCP19 only grew on SD -WLH indicating a weak  
147 interaction whereas a stronger interaction was detected between BD-PRR2 and AD-TCP20 as  
148 shown by the yeast growth on a more selective medium SD-WLHA. To ensure that negative  
149 results cannot be associated with misexpression of TCP recombinant proteins, we checked for  
150 the presence of the full fusion proteins in yeast cells by western blots using antibodies against  
151 HA or Myc epitope and could confirm that proteins corresponding to the set of tested TCPs  
152 were correctly expressed (Figure S1).

153 We also carried out vector-swapping experiments to validate the interaction between PRR2  
154 and TCPs. When combined with the empty pGADT7 vector, the GAL4 BD–TCPs constructs were  
155 found to autonomously activate the transcription of the *HIS3* reporter gene (SD -WLH) (Figure  
156 S2A). Therefore, the interactions were tested at a high stringency by adding 3-AT, a  
157 competitive inhibitor of the *HIS3* gene product (Figure S2B). Increasing stringency reduced the  
158 level of auto-activation for all tested BD-TCPs except for the BD-TCP10 construct (Figure S2B).  
159 Thus, in this condition we could not conclude on the interaction between BD-TCP10 and AD-  
160 PRR2 due to the significant auto-activation of BD-TCP10. Nevertheless, we used this swapping  
161 experiment in presence of 3-AT to validate the results reported in Figure 1B. Thus taking into  
162 account that auto-activation is not fully prevented by using 3-AT in presence of AD-Empty (Fig  
163 S2), we conclude that TCP12 did not interact with PRR2 (Figure S3). Similarly, according to the

164 results obtained in these experiments (Figure S2 and S3) we conclude that TCP14 did not  
165 interact with PRR2. However, an interaction was detected between AD-PRR2 and BD-TCP13,  
166 BD-TCP15 and BD-TCP20 (Figure S3). In these conditions, BD-TCP19 seemed to not or faintly  
167 interact with AD-PRR2 but since it was strongly interacting when co-expressed as AD fusion  
168 (Figure 1B) we decided to keep it for further experiments. Combining the results obtained  
169 from both configurations, we conclude that PRR2 is able to interact in yeast with TCP15,  
170 TCP19, TCP13 and TCP20.

171

### 172 1.3.2 Mapping of the TCP-binding domain in PRR2

173 To map the PRR2 region taking part in the interaction between PRR2 and TCPs, the AD-TCP  
174 fusion proteins (TCP13, TCP15, TCP19 and TCP20) and three truncated forms of PRR2 (Figure  
175 2A) were co-expressed in yeast for two-hybrid interaction analysis. When PRR2 ( $\Delta$ 297-535)  
176 construct was deleted of the C-terminal part and only contained the receiver domain (Figure  
177 2A), co-transformed yeasts did not grow on selective media indicating that the four tested  
178 TCPs do not interact with the C-terminus deleted form of PRR2 (Figure 2B). On the contrary,  
179 TCPs interact with the construct deleted of the N-terminal part of PRR2 (PRR2 ( $\Delta$ 1-296)) as  
180 indicated by the growth of co-transformed yeasts on both SD-WLH and SD-WLHA selective  
181 media (Figure 2C). All the deletions of PRR2 used for this analysis were appropriately  
182 expressed in yeasts (Figure S4) indicating that the absence of growth of transformed yeasts  
183 on selective medium would be correlated to the absence of interaction. According to these  
184 results, we propose that the TCPs could interact with the C-terminus part of PRR2 that  
185 contains the GARP domain, the proline-rich region and the GCT motif. When the GCT box like  
186 is removed from the PRR2 protein sequence, two different interaction profiles were obtained  
187 (Figure 2D). TCP13 and TCP20 are no longer able to interact with PRR2 whereas yeasts carrying  
188 BD-PRR2 and AD-TCP15 or AD-TCP19 can still grow on the most selective media (Figure 2D).  
189 Collectively, these results suggest that these TCPs members can interact with PRR2 in a  
190 different manner. TCP13 and TCP20 can interact with a part of the PRR2 c-terminal end  
191 including the GCT box whereas TCP15 and TCP19 interact with the central domain containing  
192 the GARP and the PRO rich domain specific to PRR2 (Figure 2A).

193

### 194 1.3.3 PRR2 interacts with TCP19 and TCP20 in the plant cell nucleus

195 To validate PRR2/TCPs interactions observed in the yeast two-hybrid system; a  
196 fluorophore-tagged protein interaction assay based on FRET and fluorescence lifetime imaging  
197 microscopy (FRET-FLIM approach) was developed [34]. We selected two TCPs, TCP19 and  
198 TCP20, that exhibit a reproducible and strong interaction in yeast and TCP12 as a negative  
199 control. Proteins were tagged with either CFP or YFP, and we first examined their subcellular  
200 localizations after agroinfiltration in *Nicotiana benthamiana* leaves. As previously shown by  
201 Perochon *et al.* (2010) [12], confocal microscopy analyses indicate that PRR2–CFP is localized  
202 in the nucleus. Subcellular localization of YFP-TCP12, -19 and -20 fusion proteins in  
203 transformed tobacco epidermal cells indicate, as expected for TFs, a nuclear localization. The  
204 co-localization of PRR2 and TCPs in the plant cell nucleus in addition to the yeast two-hybrid  
205 results led us to examine the physical interaction between PRR2 and the two selected TCPs in  
206 plant cells through a FRET-FLIM approach. Mean lifetime of PRR2-CFP in nuclei of *N.*  
207 *benthamiana* epidermal cells was analyzed either when expressed alone or after co-  
208 expression with the three fluorescent TCPs proteins 12, 19 and 20 (Table 1). For this purpose,  
209 the YFP was fused to the N-terminus of the TCP proteins. We observed that when PRR2 was  
210 co-expressed with TCP19 or TCP20 the CFP fluorescence in the CFP channel can be detected  
211 and measured but not when PRR2-CFP was expressed alone (Table 1). In order to be able to  
212 measure the mean lifetime of PRR2-CFP, we co-express it with a non-fluorescent construct of  
213 TCP19 fused to HA. In these conditions the CFP fluorescence was detectable and the mean  
214 lifetime could be measured (Table 1). As a negative control we used TCP12 that (i) does not  
215 interact with PRR2 (Figure 1B) but like TCP19 or 20 (i) exhibits a nuclear localization in plant  
216 cells. This negative control allowed us to verify that the accumulation of the fusion proteins  
217 (PRR2-CFP and YFP-TCP12) due to over-expression does not cause an artefactual protein–  
218 protein interaction. Indeed, the averaged CFP lifetime in nuclei of plant cells co-expressing  
219 PRR2–CFP and YFP-TCP12 is similar to that obtained when PRR2–CFP is co-expressed with HA-  
220 TCP19 (Table 1). This result confirms the lack of interaction previously observed using the two-  
221 hybrid system. Conversely, significant reductions of the average CFP lifetime were measured  
222 in nuclei of cells co-expressing PRR2–CFP and YFP-TCP19 or YFP-TCP20 (Table 1). FRET  
223 efficiencies of 16.6% and 10.5% for PRR2-CFP/YFP-TCP19 and PRR2-CFP/YFP-TCP20

224 respectively, were calculated with a high statistical confidence (Table 1). These results support  
225 the intermolecular interaction between PRR2 and TCP19 or TCP20 in plant cells.

#### 226 **1.3.4 PRR2-TCP interaction stabilizes the PRR2 protein in *N. benthamiana* leaves**

227 As already mentioned above, FRET-FLIM experiments also suggested that PRR2 detection  
228 is improved when it is co-expressed with TCP19 or TCP20. This raises the hypothesis that the  
229 interactions with TCPs enhance the stability of PRR2 in tobacco leaves (Figure 3A and B).  
230 Indeed, as indicated in Figure 3A, when PRR2-CFP (*35S promoter::PRR2-CFP*) is expressed in  
231 tobacco leaves alone, a very low level of fluorescence was detected in the CFP channel using  
232 wide field microscopy. The same result is also obtained when TCP12, a non-interacting TCP, is  
233 co-expressed with PRR2 (Figure 3A). In contrast, PRR2-CFP was more easily detected when the  
234 construct was transiently co-expressed with TCP19 or TCP20 (*35S promoter::YFP-TCP19* or  
235 *35Spromoter::YFP-TCP20*) in *N. benthamiana* epidermal cells (Figure 3A). To exclude the  
236 possibility of an artefactual stabilization of PRR2 due to the expression of the YFP protein, we  
237 also studied the co-expression of PRR2-CFP with YFP (Figure S5). In such condition, no  
238 difference was observed compared to PRR2-CFP alone which confirms the previous results  
239 obtained with YFP-TCP12. Quantitative analyses were performed by counting the number of  
240 PRR2-CFP fluorescent nuclei in co-transformed (+YFP, +YFP-TCP12, +YFP-TCP19 or +YFP-  
241 TCP20) or not (PRR2-CFP alone) tobacco leaf tissues (Figure 3B). Analyses were made on  
242 randomly selected fields (9 x 1.3mm<sup>2</sup>) on nine independent biological replicates. The results  
243 are illustrated in figure 3B. When PRR2 is expressed alone (Figure 3B), the number of detected  
244 PRR2-CFP nuclei is between 20 and 150 per 12 mm<sup>2</sup>. No significant difference was observed  
245 when PRR2-CFP is co-expressed either with YFP alone or with YFP-TCP12 (Figure 3B). When  
246 PRR2-CFP and YFP-TCP19 are co-expressed in tobacco leaves, a significant increase of the  
247 number of PRR2-CFP fluorescent nuclei (3 to 12 times more) was quantified compared to the  
248 situation with PRR2-CFP alone (Figure 3B). A similar result was also obtained with YFP-TCP20  
249 (Figure 3B). The fact that co-expression of PRR2-CFP with YFP-TCP12 display the same image  
250 than expression of PRR2-CFP alone, indicates that expression of YFP is not involved in the  
251 artefactual stabilization of PRR2 but rather TCP19 and TCP20 are likely involved in this  
252 stabilization.

253 As PRR2 is also able to interact with the calcium sensor protein CML9, in yeast two hybrid  
254 and *in planta* as previously reported by Perochon *et al.* (2010) [12], comparable experiments

255 were conducted with CML9. Nuclei expressing PRR2-CFP were counted in the presence of YFP-  
256 CML9 and no significant increase in their number was observed indicating that, conversely to  
257 TCP19 and TCP20, CML9 doesn't contribute to PRR2 stabilization in the nuclear compartment  
258 (Figure 3C).

259 Collectively, these data indicate that the enhancement of PRR2-CFP detection is only  
260 observed when PRR2 is co-expressed with an interacting TCP and support the idea that PRR2  
261 might be stabilized at the protein level in the nuclear compartment by a TCP-dependent  
262 process.

263 Activities of many plant TFs are often regulated by proteolysis that involves the  
264 ubiquitin/26S proteasome complex [35]. *in silico* analysis using different bioinformatics tools  
265 (UbPred [36], CKSAAP-Ubsite [37, 38]) to predict the ubiquitination sites in the PRR2 protein  
266 sequence was performed. Results obtained indicate a significant enrichment in potential  
267 ubiquitination sites in the central part of the protein (Figure 4A). To test the hypothesis that  
268 this region might be associated with the stability of the ectopic PRR2 protein, we expressed  
269 the PRR2( $\Delta$ 1-296)-CFP form in tobacco leaves (Figure 4B). This PRR2 construct is devoid of most  
270 putative ubiquitination sites (Figure 4A). We compared both the behavior of the full length  
271 PRR2-CFP protein and its truncated form when expressed in plant tissues (Figure 4B). The  
272 quantitative analysis indicates a significant increase in the number of nuclei expressing  
273 PRR2( $\Delta$ 1-296)-CFP (4 to 13 times more) compared to the full-length PRR2-CFP (Figure 4B). Thus,  
274 the deletion of the N-terminus of PRR2 protein enhances the effectiveness of PRR2-CFP  
275 expression possibly by increasing the stability of the protein.

### 276 **1.3.5 Stabilization of PRR2 occurs in specific nuclear sub-domains according to the** 277 **nature of the TCP co-expressed**

278 A deeper analysis of the sub-nuclear distribution of TCPs and PRR2 was performed on  
279 independent samples from biological replicates using confocal microscopy. While PRR2-CFP is  
280 detected everywhere in the nucleoplasm (Figure 5A), YFP-TCP19 is mainly detected in two  
281 nuclear foci (Figure 5A), whereas YFP-TCP20 exhibits a different pattern of fluorescence with  
282 a labelled nucleoplasm but also several small spots of concentrated fluorescence (Figure 5A).  
283 We previously established that PRR2 is able to physically interact in the plant nucleus with  
284 both TCP19 and TCP20. We investigated if these interactions might affect the sub-nuclear

285 localization of PRR2, TCP or both (Figure 5). PRR2-CFP and YFP-TCP(-19 or -20) were co-  
286 expressed in *N. benthamiana* and the confocal microscopy observations were made focusing  
287 on the nuclear compartment (Figure 5B and C). Interestingly, when PRR2-CFP is co-expressed  
288 with YFP-TCP19, a fluorescence emission that perfectly co-localizes with YFP-TCP19 is  
289 detected in the CFP channel (Figure 5B). We also observed that PRR2-CFP distribution is also  
290 different from PRR2-CFP alone when co-expressed with YFP-TCP20 . In this later case, as  
291 shown in Figure 5C, PRR2-CFP co-localized in the same nuclear sub-domain than YFP-TCP20.

292 In order to identify these nuclear sub-domains the localization of these TCPs has been  
293 refined by co-expressing these constructs with specific markers of nuclear structures (Figure  
294 5D). Thus, we used the COILIN1 protein (COIL1-YFP) which is described to be specifically  
295 targeted to Cajal bodies [32] and the zinc finger protein SERRATE (SERRATE-RFP) which is  
296 associated with nuclear speckles in plant cells (Figure 5D) [33]. Data showed that TCP19 co-  
297 localizes with COIL1-YFP (Figure 5B) but not with SERRATE (data not shown) whereas YFP-  
298 TCP20 pattern perfectly overlaps with the SERRATE-RFP profile (Figure 5D) but not with COIL1  
299 (data not shown). These results indicate that TCP19 and the complex with PRR2 is located in  
300 Cajal bodies while TCP20 and its complex with PRR2 is mainly distributed in sub-nuclear  
301 speckles.

302 All together, these data indicate that PRR2-CFP which is distributed throughout the  
303 nucleoplasm when expressed alone undergoes a re-localization in specific nuclear sub-  
304 compartments depending upon its association with a particular TCP.

305



## 306 1.4 DISCUSSION

307 Analysis of the Arabidopsis interactome strengthen the data indicating that plant TFs  
308 function and regulation are controlled by multiple factors [39]. For instance, the importance  
309 of protein-protein interactions between members of a same TF family is well established since  
310 most TFs can physically interact to form dimer to multimer complexes. This view has been  
311 complexified by the fact that a significant number of TF interactions take place between  
312 members of different families [20, 40]. Here, we bring new results concerning PRR2, a plant  
313 specific TF that exerts dual role in plant physiology, both in plant development [19] and in  
314 plant immunity [18] and it is able to interact with selected TCPs. Indeed, TCPs could act as  
315 integrators of plant responses to environment issues [25] and recent studies have  
316 demonstrated that they also function as cellular hubs in plant defense signaling [27, 41, 42].  
317 The systematic analysis of binary protein-protein interactions between *Arabidopsis* proteins  
318 and effector proteins produced by 3 pathogens (*Pseudomonas syringae*, *Hyaloperonospora*  
319 *arabidopsidis* and the fungus *Golovinomyces orontii*), showed that TCP13, TCP14, TCP15 and  
320 TCP19 are directly targeted by effectors from these pathogens [27, 41].

321 We demonstrated here, that several TCPs are able to interact with PRR2 but these  
322 interactions occurred in different ways. TCP13 and TCP20 might interact with the GCT box like  
323 present in the C-terminus part of PRR2 whereas TCP15 and TCP19 might specifically interact  
324 with a central sequence containing the GARP and the PRO rich domains (Figure 2). In this later  
325 case, we can imagine that the interaction might result in an altered DNA-binding capacity. In  
326 addition, we cannot rule-out that in some particular physiological conditions, several TCPs can  
327 simultaneously bind a unique PRR2 protein through the different interacting modes.

328 A very few analyses have been performed on TCP19 and cellular mechanisms controlled by  
329 this TF are still unknown [31]. TCP15 has been shown to interact with others PRRs (PRR1/TOC1  
330 and PRR5) in yeast two-hybrid [43]. PRR1 and PRR5 belong to a specific sub-group of PRR  
331 characterized by the occurrence of a CCT motif (first characterized in CONSTANS, a key  
332 regulator of plant flowering) in the carboxy-terminal end of the protein [15]. PRRs belonging  
333 to this group (PRR9, PRR7, PRR5, PRR3 and PRR1/TOC1) are involved in the circadian rhythm  
334 [44, 45] whereas PRR2 belongs to the second sub-group characterized by the presence of a  
335 MYB related DNA-binding domain [16].

336 In order to determine if the PRR2–TCP interactions shown by the two-hybrid approach  
337 could occur in *Arabidopsis* cells, we have examined whether these genes (PRR2, TCP13, 15,  
338 19, 20) exhibit a compatible expression pattern and if the proteins are localized in the same  
339 cellular compartments. According to the *Arabidopsis* databases (Geneinvestigator [46] and eFP  
340 Browser [47]) and from our own analyses [18], the constitutive expression of *PRR2* in different  
341 organs throughout plant development roughly coincides with that of these *TCP* genes.  
342 Moreover, as expected for transcriptional regulators, PRR2 [12] and most of the analyzed TCPs  
343 are nuclear proteins [28, 48, 49]. An exception is TCP13 (PTF1) that has been detected in the  
344 chloroplast where it regulates chloroplastic genes [50]. This result could indicate that *in*  
345 *planta*, the interaction between PRR2 and TCP13 cannot occur since PRR2 is strictly restricted  
346 to the nucleus although we detected an interaction in yeast two-hybrid assays. The FRET-FLIM  
347 analyses allowed to validate the *in planta* interactions between PRR2 and TCP19 and between  
348 PRR2 with TCP20 (Table 1).

349 The physical interaction of PRR2 with TCPs (*i.e.* TCP19 and 20) both in yeast and in plant  
350 cells, supports that these interactions are likely to be relevant in modulating PRR2 function  
351 during plant development and/or in response to stress. Indeed, transcription factors are  
352 considered as master regulators involved in important plant responses associated to genetic  
353 reprogramming and it is well acknowledged that their activity need to be highly and finely  
354 tuned. Thus, different regulatory mechanisms such as post-translational modifications,  
355 protein-protein interactions, protein degradation or stabilization but also protein re-  
356 localization can be considered [3]. These interactions are highly dynamic and might affect  
357 positively or negatively the stability of the complex, modify DNA binding activities and have  
358 consequences on the expression of target genes [39]. Interestingly, we observed through  
359 cytological analyses a clear effect of the co-expression of PRR2 with interacting TCPs on the  
360 fate of the PRR2 protein or at least the ability to detect the protein (Figures 3 and 4). When  
361 PRR2 is expressed alone, a weak nuclear detection of PRR2 is observed whereas this detection  
362 is significantly enhanced when PRR2 is co-expressed with TCP19 or TCP20. This observation  
363 questions about the stability of PRR2 protein and suggests the possibility that the PRR2-TCP  
364 interaction might stabilize the complex. This effect is specifically observed with the PRR2-TCP  
365 combination because with CML9, a known interactor of PRR2, there is no PRR2 stabilization  
366 observed (Figure 3C). In plants, the stability control of many transcriptional regulators is  
367 mediated by the ubiquitin-mediated proteasome [3]. Using *in silico* predicting tools on the

368 PRR2 protein sequence (UbPred, CSSK UBSite) [36, 38], numerous putative ubiquitination sites  
369 were found and are mostly present in the central part of PRR2 (Figure 4A). We speculate that  
370 ubiquitination and proteasome activity might be linked to the PRR2 instability and that the  
371 interaction with TCPs could hide the ubiquitination sites and prevent PRR2 degradation. This  
372 hypothesis is supported by the observation that the truncated form of PRR2 (missing the  
373 predicted ubiquitination sites) is more easily detected and thus more stable when ectopically  
374 expressed in plant cells (Figure 4B). To go further, we tried to use the proteasome inhibitor  
375 (MG132) to observe if such treatment could enhance PRR2 detection, but unfortunately,  
376 results obtained with this pharmacological approach, do not allowed us to draw a clear  
377 conclusion (data not shown). Additionally, it has been shown by Tokumaru *et al.* that GLK1 is  
378 targeted by the ubiquitin-proteasome system suggesting that the GARP transcription factor  
379 family might be highly regulated by post-translational modifications [51]. Recent reports  
380 suggest that additional post-translational modifications modulate the ubiquitination and thus  
381 the stability of transcriptional regulators [3]. Conjugation to the ubiquitin-like protein SUMO  
382 (Small Ubiquitin-like MOdifier) is emerging as a key regulatory step for governing protein  
383 ubiquitination in the nucleus [52, 53]. *Arabidopsis* SUMOylated proteins were identified by  
384 tandem mass spectrometry from plant tissues by Miller *et al.* (2010) and PRR2 was present  
385 among the 357 SUMO targets found in this work [54]. The identified SUMO attachment sites  
386 in PRR2 protein sequence are localized at positions 183 (LKQD) and 240 (VKEE) [54] that  
387 correspond to the same region previously described to be enriched in putative ubiquitination  
388 sites (Figure 4A). The covalent conjugation of SUMO protein to its substrates regulates  
389 numerous cellular processes, including protein stability and activity in plants as well as in all  
390 eukaryotes [53, 55, 56]. Therefore, we cannot exclude that the results obtained Figure 4B  
391 could be explained with PRR2 SUMOylation, leading to a better-stabilized protein and/or any  
392 other modification in PRR2 protein properties including interacting activities. This hypothesis  
393 still needs to be experimentally explored and the identification of SUMO attachment sites in  
394 PRR2 sequence will be helpful for future site-mutagenesis studies to assess the role of  
395 SUMOylation in the function of PRR2 protein. It is also noteworthy that a recent study report  
396 that some TCPs are able to interact with the SUMO conjugating machinery [49]. Among these  
397 TCPs, TCP19 was reported to interact in yeast two-hybrid with elements of this machinery.  
398 Interestingly TCP3, 8, 14 and 15 exhibited a redistribution into nuclear bodies when they  
399 interacted with SCE1 (SUMO conjugating Enzyme) [49].

400 Additionally, we showed that TCP19 and TCP20 mediate the localization of PRR2 in  
401 particular nuclear sub-domains that correspond to Cajal bodies and nuclear speckles.  
402 According to literature, the accumulation of nuclear factors in distinct nuclear bodies may help  
403 to generate a high local concentration of components. This could ultimately either enhance  
404 or decrease the biological function of such proteins [57, 58]. This sub-nuclear  
405 compartmentalization process might also contribute to modify the PRR2 protein behavior and  
406 contribute to regulate its stability or activity. Thereby, during light regulation of plant  
407 development, it has been shown that CRY2 (Cryptochrome 2), a blue light receptor, can  
408 accumulate in nuclear bodies upon blue light exposure [59]. This CRY2 sub-nuclear localization  
409 is associated with a significantly delayed degradation of CRY2 [59]. According to the authors,  
410 the photoexcited CRY2-GFP form would accumulate or migrate in the nuclear bodies where it  
411 would be ubiquitinated and degraded by the 26S proteasome [59]. As previously mentioned,  
412 a clear link between the sub-nuclear compartmentalization and the ubiquitination and/or  
413 SUMOylation processes is not yet formally established in plant cells. Nevertheless, the fact  
414 that SUMOylation could alter protein turnover rate has been proposed [60]. Thus, data  
415 suggest that SUMOylation by SIZ1 stabilizes the TF MYB30 [61]. In the same way, it was  
416 established that the SUMOylation increases RACK1B (Receptor for Activated C Kinase 1)  
417 stability and its tolerance to ubiquitination-mediated degradation in ABA response [62]. On  
418 the basis of the information gathered in yeast or animal models, an emerging concept where  
419 nuclear bodies could act as sites of protein modification by SUMO and/or proteasomal  
420 degradation of ubiquitin-tagged proteins can be proposed [53, 63].

421 PRR2 post-translational modifications as well as PRR2 interactions may provide important  
422 control mechanisms to fine tune PRR2 activities. To fully decipher the function of PRR2, it will  
423 be of interest to determine the fate of the active PRR2 protein and to unravel the  
424 environmental and intrinsic signals that control its total cellular level. Forthcoming research  
425 will also rely on the identification of PRR2 target genes to better understand the biological  
426 relevance of PRR2 in plant development and stress responses.

427

## 428 SUPPLEMENTARY MATERIAL

429 **Figure S1:** Western blot detection of the recombinant TCP and PRR2 proteins in yeast two-  
430 hybrid experiments.

431 **Figure S2:** Auto-activation analyses of TCPs belonging to the Class I and Class II in yeast two-  
432 hybrid system.

433 **Figure S3:** Vector swapping experiment of the interaction profile of PRR2 with selected TCPs  
434 by yeast two-hybrid approach.

435 **Figure S4:** Western blot detection of the deleted forms of PRR2 proteins in yeast two- hybrid  
436 experiments.

437 **Figure S5:** Detection of PRR2-CFP fluorescent nuclei in *Nicotiana benthamiana* in the presence  
438 or in the absence of YFP.

439

## 440 ACKNOWLEDGMENTS:

441 We thank the technical services of the laboratory for plant material and technical assistance.  
442 We are grateful to L. Camborde and E. Gaulin for kind gift for the constructs used as plant  
443 nuclear markers.

444

## 445 FUNDING:

446 The University Toulouse, the CNRS supported this work. MP is fellow from the French Ministry  
447 of National Education and Research. YG is fellow from the ENS Lyon. This work was supported  
448 by the French Laboratory of Excellence project "TULIP" (ANR-10-LABX-41; ANR-11-IDEX-0002-  
449 02).

## 450 AUTHORS' CONTRIBUTIONS

451 MP performed all experiments. YG and EP cloned various TCP genes in AD and BD yeast vectors  
452 and performed yeast two-hybrid experiments. AJ and CP performed FRET-FLIM assays and  
453 confocal microscopy analyses. MP, CM, JPG, BR and DA analyzed the data and participated in

454 writing of the manuscript. DA supervised the project and wrote the final draft of the  
455 manuscript. All the authors read and approved the final manuscript.

456

457

## REFERENCES

- [1] N. Sewelam, K. Kazan, P.M. Schenk, Global Plant Stress Signaling: Reactive Oxygen Species at the Cross-Road, *Front Plant Sci*, 7 (2016) 187.
- [2] P. Buscaill, S. Rivas, Transcriptional control of plant defence responses, *Curr Opin Plant Biol*, 20C (2014) 35-46.
- [3] M.J. Skelly, L. Frungillo, S.H. Spoel, Transcriptional regulation by complex interplay between post-translational modifications, *Curr Opin Plant Biol*, 33 (2016) 126-132.
- [4] A.S. Reddy, G.S. Ali, H. Celesnik, I.S. Day, Coping with stresses: roles of calcium- and calcium/calmodulin-regulated gene expression, *Plant Cell*, 23 (2011) 2010-2032.
- [5] D. Aldon, M. Mbengue, C. Mazars, J.P. Galaud, Calcium Signalling in Plant Biotic Interactions, *Int J Mol Sci*, 19 (2018).
- [6] H. Fromm, A. Finkler, Repression and De-repression of Gene Expression in the Plant Immune Response: The Complexity of Modulation by Ca<sup>2+</sup>(+) and Calmodulin, *Mol Plant*, 8 (2015) 671-673.
- [7] Y.S. Kim, C. An, S. Park, S.J. Gilmour, L. Wang, L. Renna, F. Brandizzi, R. Grumet, M.F. Thomashow, CAMTA-Mediated Regulation of Salicylic Acid Immunity Pathway Genes in Arabidopsis Exposed to Low Temperature and Pathogen Infection, *Plant Cell*, 29 (2017) 2465-2477.
- [8] X. Zhu, C. Dunand, W. Snedden, J.P. Galaud, CaM and CML emergence in the green lineage, *Trends Plant Sci*, 20 (2015) 483-489.
- [9] L.J. Leba, C. Cheval, I. Ortiz-Martin, B. Ranty, C.R. Beuzon, J.P. Galaud, D. Aldon, CML9, an Arabidopsis calmodulin-like protein, contributes to plant innate immunity through a flagellin-dependent signalling pathway, *Plant J*, 71 (2012) 976-989.
- [10] X. Zhu, M. Perez, D. Aldon, J.P. Galaud, Respective contribution of CML8 and CML9, two arabidopsis calmodulin-like proteins, to plant stress responses, *Plant Signal Behav*, 12 (2017) e1322246.
- [11] X. Zhu, E. Robe, L. Jomat, D. Aldon, C. Mazars, J.P. Galaud, CML8, an Arabidopsis Calmodulin-Like Protein, Plays a Role in Pseudomonas syringae Plant Immunity, *Plant Cell Physiol*, (2016).
- [12] A. Perochon, S. Dieterle, C. Pouzet, D. Aldon, J.P. Galaud, B. Ranty, Interaction of a plant pseudo-response regulator with a calmodulin-like protein, *Biochem Biophys Res Commun*, 398 (2010) 747-751.
- [13] S. Makino, T. Kiba, A. Imamura, N. Hanaki, A. Nakamura, T. Suzuki, M. Taniguchi, C. Ueguchi, T. Sugiyama, T. Mizuno, Genes encoding pseudo-response regulators: insight into His-to-Asp phosphorelay and circadian rhythm in Arabidopsis thaliana, *Plant Cell Physiol*, 41 (2000) 791-803.
- [14] K. Ishida, T. Yamashino, A. Yokoyama, T. Mizuno, Three type-B response regulators, ARR1, ARR10 and ARR12, play essential but redundant roles in cytokinin signal transduction throughout the life cycle of Arabidopsis thaliana, *Plant Cell Physiol*, 49 (2008) 47-57.
- [15] T. Mizuno, Two-component phosphorelay signal transduction systems in plants: from hormone responses to circadian rhythms, *Biosci Biotechnol Biochem*, 69 (2005) 2263-2276.
- [16] G.E. Schaller, J.J. Kieber, S.H. Shiu, Two-component signaling elements and histidyl-aspartyl phosphorelays, *Arabidopsis Book*, 6 (2008) e0112.
- [17] M. Chen, M. Ji, B. Wen, L. Lui, S. Li, X. Chen, D. Gao, L. Li, GOLDEN 2-LIKE Transcription Factors of Plants, *Front Plant Sci*, 7 (2016) 1-5.
- [18] C. Cheval, M. Perez, L.J. Leba, B. Ranty, A. Perochon, M. Reichelt, A. Mithofer, E. Robe, C. Mazars, J.P. Galaud, D. Aldon, PRR2, a pseudo-response regulator, promotes salicylic acid and camalexin accumulation during plant immunity, *Scientific reports*, 7 (2017) 6979.
- [19] Y. Pan, G. Bradley, K. Pyke, G. Ball, C. Lu, R. Fray, A. Marshall, S. Jayasuta, C. Baxter, R. van Wijk, L. Boyden, R. Cade, N.H. Chapman, P.D. Fraser, C. Hodgman, G.B. Seymour, Network inference analysis identifies an APRR2-like gene linked to pigment accumulation in tomato and pepper fruits, *Plant Physiol*, 161 (2013) 1476-1485.
- [20] C. Arabidopsis Interactome Mapping, Evidence for network evolution in an Arabidopsis interactome map, *Science*, 333 (2011) 601-607.

- [21] M. Nicolas, P. Cubas, TCP factors: new kids on the signaling block, *Curr Opin Plant Biol*, 33 (2016) 33-41.
- [22] E. Gonzalez Grandio, P. Cubas, TCP Transcription Factors: Evolution, Structure, and Biochemical Function, 2015.
- [23] M. Martin-Trillo, P. Cubas, TCP genes: a family snapshot ten years later, *Trends Plant Sci*, 15 (2010) 31-39.
- [24] J.A. Lopez, Y. Sun, P.B. Blair, M.S. Mukhtar, TCP three-way handshake: linking developmental processes with plant immunity, *Trends Plant Sci*, 20 (2015) 238-245.
- [25] S. Danisman, TCP Transcription Factors at the Interface between Environmental Challenges and the Plant's Growth Responses, *Front Plant Sci*, 7 (2016) 1930.
- [26] L. Yang, P.J. Teixeira, S. Biswas, O.M. Finkel, Y. He, I. Salas-Gonzalez, M.E. English, P. Epple, P. Mieczkowski, J.L. Dangl, *Pseudomonas syringae* Type III Effector HopBB1 Promotes Host Transcriptional Repressor Degradation to Regulate Phytohormone Responses and Virulence, *Cell Host Microbe*, 21 (2017) 156-168.
- [27] R. Weßling, P. Epple, S. Altmann, Y. He, L. Yang, S.R. Henz, N. McDonald, K. Wiley, K.C. Bader, C. Glasser, M.S. Mukhtar, S. Haigis, L. Ghamsari, A.E. Stephens, J.R. Ecker, M. Vidal, J.D. Jones, K.F. Mayer, E. Ver Loren van Themaat, D. Weigel, P. Schulze-Lefert, J.L. Dangl, R. Panstruga, P. Braun, Convergent targeting of a common host protein-network by pathogen effectors from three kingdoms of life, *Cell Host Microbe*, 16 (2014) 364-375.
- [28] X. Wang, J. Gao, Z. Zhu, X. Dong, X. Wang, G. Ren, X. Zhou, B. Kuai, TCP transcription factors are critical for the coordinated regulation of isochorismate synthase 1 expression in *Arabidopsis thaliana*, *Plant J*, 82 (2015) 151-162.
- [29] J.M. Daviere, M. Wild, T. Regnault, N. Baumberger, H. Eisler, P. Genschik, P. Achard, Class I TCP-DELLA interactions in inflorescence shoot apex determine plant height, *Curr Biol*, 24 (2014) 1923-1928.
- [30] S. Danisman, F. van der Wal, S. Dhondt, R. Waites, S. de Folter, A. Bimbo, A.D. van Dijk, J.M. Muino, L. Cutri, M.C. Dornelas, G.C. Angenent, R.G. Immink, *Arabidopsis* class I and class II TCP transcription factors regulate jasmonic acid metabolism and leaf development antagonistically, *Plant Physiol*, 159 (2012) 1511-1523.
- [31] S. Danisman, A.D. van Dijk, A. Bimbo, F. van der Wal, L. Hennig, S. de Folter, G.C. Angenent, R.G. Immink, Analysis of functional redundancies within the *Arabidopsis* TCP transcription factor family, *J Exp Bot*, 64 (2013) 5673-5685.
- [32] P.J. Shaw, J.W. Brown, Plant nuclear bodies, *Curr Opin Plant Biol*, 7 (2004) 614-620.
- [33] Y. Fang, D.L. Spector, Identification of nuclear dicing bodies containing proteins for microRNA biogenesis in living *Arabidopsis* plants, *Curr Biol*, 17 (2007) 818-823.
- [34] L. Camborde, A. Jauneau, C. Briere, L. Deslandes, B. Dumas, E. Gaulin, Detection of nucleic acid-protein interactions in plant leaves using fluorescence lifetime imaging microscopy, *Nat Protoc*, 12 (2017) 1933-1950.
- [35] M. Muratani, W.P. Tansey, How the ubiquitin-proteasome system controls transcription, *Nat Rev Mol Cell Biol*, 4 (2003) 192-201.
- [36] P. Radivojac, V. Vacic, C. Haynes, R.R. Cocklin, A. Mohan, J.W. Heyen, M.G. Goebel, L.M. Iakoucheva, Identification, analysis, and prediction of protein ubiquitination sites, *Proteins*, 78 (2010) 365-380.
- [37] Z. Chen, Y. Zhou, Z. Zhang, J. Song, Towards more accurate prediction of ubiquitination sites: a comprehensive review of current methods, tools and features, *Briefings in bioinformatics*, 16 (2015) 640-657.
- [38] Z. Chen, Y.Z. Chen, X.F. Wang, C. Wang, R.X. Yan, Z. Zhang, Prediction of ubiquitination sites by using the composition of k-spaced amino acid pairs, *PLoS One*, 6 (2011) e22930.
- [39] M. Bemer, A.D. van Dijk, R.G. Immink, G.C. Angenent, Cross-Family Transcription Factor Interactions: An Additional Layer of Gene Regulation, *Trends Plant Sci*, 22 (2017) 66-80.
- [40] J. Yazaki, M. Galli, A.Y. Kim, K. Nito, F. Aleman, K.N. Chang, A.R. Carvunis, R. Quan, H. Nguyen, L. Song, J.M. Alvarez, S.S. Huang, H. Chen, N. Ramachandran, S. Altmann, R.A. Gutierrez, D.E. Hill, J.I. Schroeder, J. Chory, J. LaBaer, M. Vidal, P. Braun, J.R. Ecker, Mapping transcription factor



- interactome networks using HaloTag protein arrays, *Proc Natl Acad Sci U S A*, 113 (2016) E4238-4247.
- [41] M.S. Mukhtar, A.R. Carvunis, M. Dreze, P. Eppele, J. Steinbrenner, J. Moore, M. Tasan, M. Galli, T. Hao, M.T. Nishimura, S.J. Pevzner, S.E. Donovan, L. Ghamsari, B. Santhanam, V. Romero, M.M. Poulin, F. Gebreab, B.J. Gutierrez, S. Tam, D. Monachello, M. Boxem, C.J. Harbort, N. McDonald, L. Gai, H. Chen, Y. He, C. European Union Effectoromics, J. Vandehaute, F.P. Roth, D.E. Hill, J.R. Ecker, M. Vidal, J. Beynon, P. Braun, J.L. Dangl, Independently evolved virulence effectors converge onto hubs in a plant immune system network, *Science*, 333 (2011) 596-601.
- [42] S.H. Kim, G.H. Son, S. Bhattacharjee, H.J. Kim, J.C. Nam, P.D. Nguyen, J.C. Hong, W. Gassmann, The Arabidopsis immune adaptor SRFR1 interacts with TCP transcription factors that redundantly contribute to effector-triggered immunity, *Plant J*, 78 (2014) 978-989.
- [43] E. Giraud, S. Ng, C. Carrie, O. Duncan, J. Low, C.P. Lee, O. Van Aken, A.H. Millar, M. Murcha, J. Whelan, TCP transcription factors link the regulation of genes encoding mitochondrial proteins with the circadian clock in Arabidopsis thaliana, *Plant Cell*, 22 (2010) 3921-3934.
- [44] E.M. Farre, T. Liu, The PRR family of transcriptional regulators reflects the complexity and evolution of plant circadian clocks, *Curr Opin Plant Biol*, 16 (2013) 621-629.
- [45] N. Nakamichi, T. Kiba, R. Henriques, T. Mizuno, N.H. Chua, H. Sakakibara, PSEUDO-RESPONSE REGULATORS 9, 7, and 5 are transcriptional repressors in the Arabidopsis circadian clock, *Plant Cell*, 22 (2010) 594-605.
- [46] T. Hruz, O. Laule, G. Szabo, F. Wessendorp, S. Bleuler, L. Oertle, P. Widmayer, W. Gruissem, P. Zimmermann, Genevestigator v3: a reference expression database for the meta-analysis of transcriptomes, *Adv Bioinformatics*, 2008 (2008) 420747.
- [47] D. Winter, B. Vinegar, H. Nahal, R. Ammar, G.V. Wilson, N.J. Provart, An "electronic fluorescent pictograph" browser for exploring and analyzing large-scale biological data sets, *PLoS One*, 2 (2007) e718.
- [48] E. Steiner, S. Livne, T. Kobinson-Katz, L. Tal, O. Pri-Tal, A. Mosquna, D. Tarkowska, B. Mueller, P. Tarkowski, D. Weiss, The Putative O-Linked N-Acetylglucosamine Transferase SPINDLY Inhibits Class I TCP Proteolysis to Promote Sensitivity to Cytokinin, *Plant Physiol*, 171 (2016) 1485-1494.
- [49] M.J. Mazur, B.J. Spears, A. Djajasaputra, M. van der Gragt, G. Vlachakis, B. Beerens, W. Gassmann, H.A. van den Burg, Arabidopsis TCP Transcription Factors Interact with the SUMO Conjugating Machinery in Nuclear Foci, *Front Plant Sci*, 8 (2017) 2043.
- [50] K. Baba, T. Nakano, K. Yamagishi, S. Yoshida, Involvement of a nuclear-encoded basic helix-loop-helix protein in transcription of the light-responsive promoter of psbD, *Plant Physiol*, 125 (2001) 595-603.
- [51] M. Tokumaru, F. Adachi, M. Toda, Y. Ito-Inaba, F. Yazu, Y. Hirose, Y. Sakakibara, M. Suiko, T. Kakizaki, T. Inaba, Ubiquitin-Proteasome Dependent Regulation of the GOLDEN2-LIKE 1 Transcription Factor in Response to Plastid Signals, *Plant Physiol*, 173 (2017) 524-535.
- [52] H.J. Park, W.Y. Kim, H.C. Park, S.Y. Lee, H.J. Bohnert, D.J. Yun, SUMO and SUMOylation in plants, *Mol Cells*, 32 (2011) 305-316.
- [53] M.J. Mazur, H.A. van den Burg, Global SUMO Proteome Responses Guide Gene Regulation, mRNA Biogenesis, and Plant Stress Responses, *Front Plant Sci*, 3 (2012) 215.
- [54] M.J. Miller, G.A. Barrett-Wilt, Z. Hua, R.D. Vierstra, Proteomic analyses identify a diverse array of nuclear processes affected by small ubiquitin-like modifier conjugation in Arabidopsis, *Proc Natl Acad Sci U S A*, 107 (2010) 16512-16517.
- [55] V. Verma, F. Croley, A. Sadanandom, Fifty shades of SUMO: its role in immunity and at the fulcrum of the growth-defence balance, *Mol Plant Pathol*, (2017).
- [56] H.J. Park, D.J. Yun, New insights into the role of the small ubiquitin-like modifier (SUMO) in plants, *International review of cell and molecular biology*, 300 (2013) 161-209.
- [57] A.I. Lamond, J.E. Sleeman, Nuclear substructure and dynamics, *Curr Biol*, 13 (2003) R825-828.
- [58] B. Petrovska, M. Sebela, J. Dolezel, Inside a plant nucleus: discovering the proteins, *J Exp Bot*, 66 (2015) 1627-1640.

- [59] X. Yu, R. Sayegh, M. Maymon, K. Warpeha, J. Klejnot, H. Yang, J. Huang, J. Lee, L. Kaufman, C. Lin, Formation of nuclear bodies of Arabidopsis CRY2 in response to blue light is associated with its blue light-dependent degradation, *Plant Cell*, 21 (2009) 118-130.
- [60] K. Miura, J. Lee, J.B. Jin, C.Y. Yoo, T. Miura, P.M. Hasegawa, Sumoylation of ABI5 by the Arabidopsis SUMO E3 ligase SIZ1 negatively regulates abscisic acid signaling, *Proc Natl Acad Sci U S A*, 106 (2009) 5418-5423.
- [61] Y. Zheng, K.S. Schumaker, Y. Guo, Sumoylation of transcription factor MYB30 by the small ubiquitin-like modifier E3 ligase SIZ1 mediates abscisic acid response in Arabidopsis thaliana, *Proc Natl Acad Sci U S A*, 109 (2012) 12822-12827.
- [62] R. Guo, W. Sun, Sumoylation stabilizes RACK1B and enhance its interaction with RAP2.6 in the abscisic acid response, *Scientific reports*, 7 (2017) 44090.
- [63] M. Carmo-Fonseca, M.T. Berciano, M. Lafarga, Orphan nuclear bodies, *Cold Spring Harbor perspectives in biology*, 2 (2010) a000703.

## TABLES

**Table 1. FRET-FLIM measurements indicate that PRR2 selectively interacts with TCP19 and TCP20 in the nucleus of plant cells.**

Donor	Acceptor	$\tau^a$ (Mean life time in ns)	sem <sup>b</sup>	FRET efficiency <sup>c</sup> (%)	p-value <sup>d</sup>
PRR2-CFP	-	ND	-	-	-
PRR2-CFP	HA-TCP19	3.127	0.024	-	-
PRR2-CFP	YFP-TCP19	2.609**	0.034	16.6	6.7 10 <sup>-26</sup>
PRR2-CFP	YFP-TCP20	2.799**	0.028	10.5	2.5 10 <sup>-15</sup>
PRR2-CFP	YFP-TCP12	3.152	0.032	-	0.52

(<sup>a</sup>) Mean lifetime (in nanoseconds). For each nucleus, the average fluorescence decay profile was plotted and fitted with exponential function using a nonlinear square estimation procedure. Mean lifetime was calculated according to  $\tau = \sum \alpha_i \tau_i^2 / \sum \alpha_i \tau_i$  with  $I(t) = \sum \alpha_i e^{-t/\tau_i}$ . Values are means from two independent experiments with at least 30 measurements per sample in each experiment (N=60). Data were analyzed by Student's t test with the threshold of significance indicated by asterisks, \*\*<0.01. (<sup>b</sup>) Standard error of the mean, (<sup>c</sup>) Percentage of FRET efficiency:  $E = 1 - (\tau_{DA}/\tau_D)$ . (<sup>d</sup>) The p value of the difference between the donor lifetimes in the presence and absence of acceptor (Student's t test). ND: not detectable.

## FIGURE LEGENDS

### Figure 1. Yeast two-hybrid interaction of PRR2 with TCP transcription factors.

(A) Simplified representation of a phylogenetic tree of *A. thaliana* TCP transcription factors used in this study based on the comparison of TCP domain sequences. The TCPs are divided into 2 main groups *i.e.* class I (TCP-P) and class II (TCP-C). (B) Yeast two-hybrid interaction (Y2H) assays between PRR2 and different constructs. AH109 yeast strain was co-transformed with BD-PRR2 and different AD constructs (AD-Empty and representative *Arabidopsis* TCPs (AD-TCP)), AD-Empty is used as a negative control. In each experiment, illustrated results are obtained after 5 days of yeast growth at 28°C under selective conditions for co-transformation (SD -WL) or interaction (-WLH, -WLHA). Serial dilutions of transformed yeast cells were realized (OD=1, 0.1, 0.01, 0.001) and symbolized in the form of triangles above the figures.

### Figure 2. Mapping analyses of PRR2 interactions domains with selected TCPs.

Different forms of PRR2 protein (full length and truncated forms) were used as represented in (A). The yeast cells were co-transformed with constructs containing AD-TCP13, 15, 19, 20 and BD-PRR2 ( $\Delta$ 297-535) (B); BD-PRR2 ( $\Delta$ 1-296) (C) or BD-PRR2 ( $\Delta$ 478-535) (D). The illustrated results were obtained after five days of growth at 28°C under selective conditions for co-transformation (SD -WL) and interaction (-WLH, -WLHA). Serial dilutions of transformed yeast cells were realized (OD=1, 0.1, 0.01, 0.001) and symbolized in the form of triangles above the figures.

### Figure 3. Co-expression of TCP19 and TCP20 stabilizes PRR2 in plant cell nucleus

(A) Wide field microscopy images of representative tobacco leaves expressing only the PRR2-CFP fluorescent protein or co-expressing the PRR2-CFP protein with YFP-TCP12, -TCP19 or -TCP20. Confocal images were taken 48 hours after agro-infiltration. Scale bars = 170 $\mu$ m. (B and C) Quantitative analyses of the number of nuclei expressing the CFP in different experimental conditions. (B) The PRR2-CFP fluorescent nuclei were quantified in tobacco discs expressing only PRR2-CFP or co-expressing PRR2-CFP with the control construct (YFP alone) or YFP-TCPs (12, 19, and 20). (C) The same experiment was performed by co-expressing PRR2 with

CML9, a calcium sensor identified as a PRR2 interacting protein (Perochon et al., 2010). The data are illustrated in the form of box-and-whisker plots that represent three independent experiments. Center lines are medians, boxes show the upper and lower quartiles and whiskers show the full data range except the outliers. Data were analyzed by *Student's t* test and threshold of significance is indicated by asterisks (\* $P < 0.05$ ).

**Figure 4. Detection of a truncated form of PRR2 devoid of predicted ubiquitination sites in *Nicotiana benthamiana* leaves.**

(A) Schematic representation of PRR2 and its truncated form deleted of the predicted sites of ubiquitination indicated with blue and red tags in the central part of the PRR2 protein. This prediction was made using the UbPred online tool [36]. In addition, the SUMOylation sites experimentally determined by Miller et al. (2010) [54] are also indicated (yellow tag). (B) Quantitative analyses of the number of nuclei expressing PRR2-CFP or the truncated form PRR2( $\Delta$ 1-296)-CFP in tobacco leaf discs. The box-and-whisker plots represent three independent experiments. Center lines are medians, boxes show the upper and lower quartiles and whiskers show the full data range except the outliers. Data were analyzed by *Student's t* test and threshold of significance is indicated by asterisks (\*\* $P < 0.01$ ).

**Figure 5. PRR2 is localized in specific nuclear sub-domains when it is co-expressed with TCP19 or TCP20.**

(A) Confocal images of representative epidermal cells expressing either PRR2-CFP, YFP-TCP-19 (-20) alone, or co-expressing both proteins (B and C). In these experiments, the PRR2 protein is detected in the CFP channel (left), the TCP in the YFP channel (middle) and an overlay with 3D projections (Right). (D) TCP fusion proteins were co-expressed with a Cajal bodies marker protein (COIL1-YFP) or nuclear speckles marker (SERRATE-RFP). Right panel is the merge of middle and left panel and show the co-localization of TCPs with the respective markers.

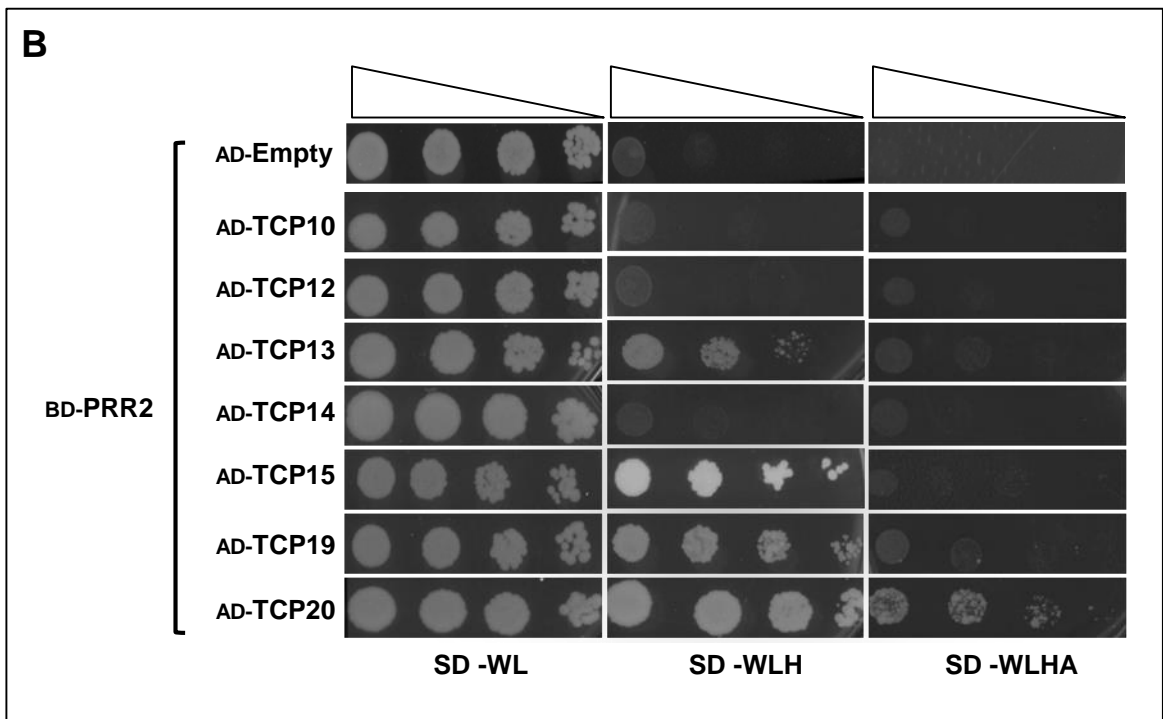
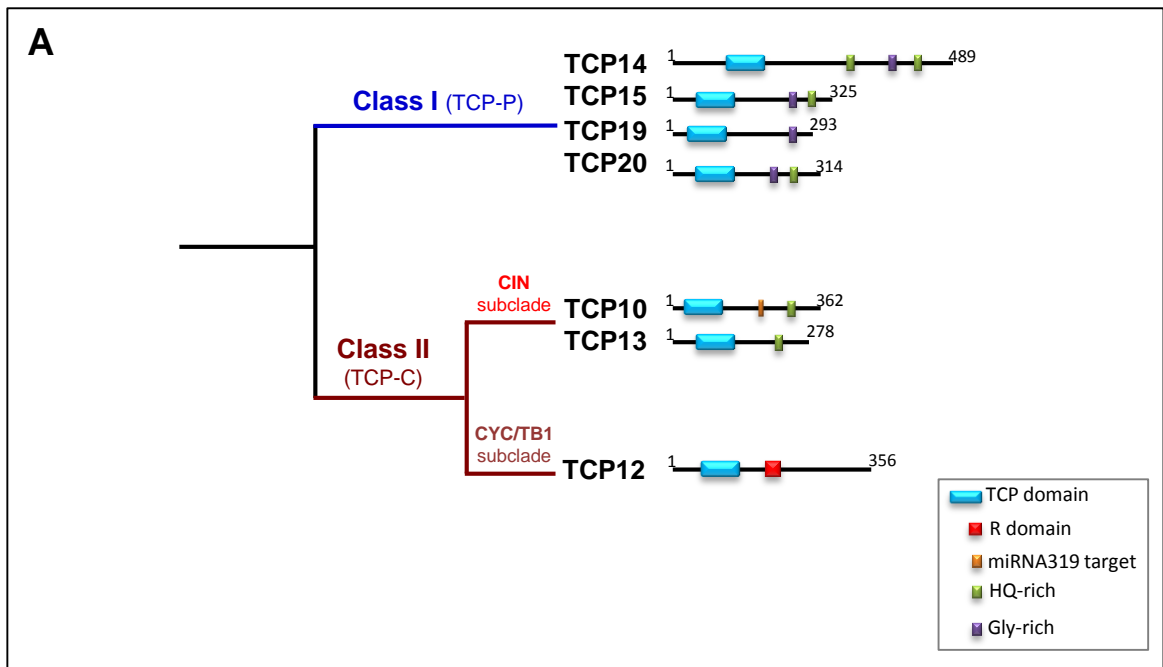

**Figure 1**

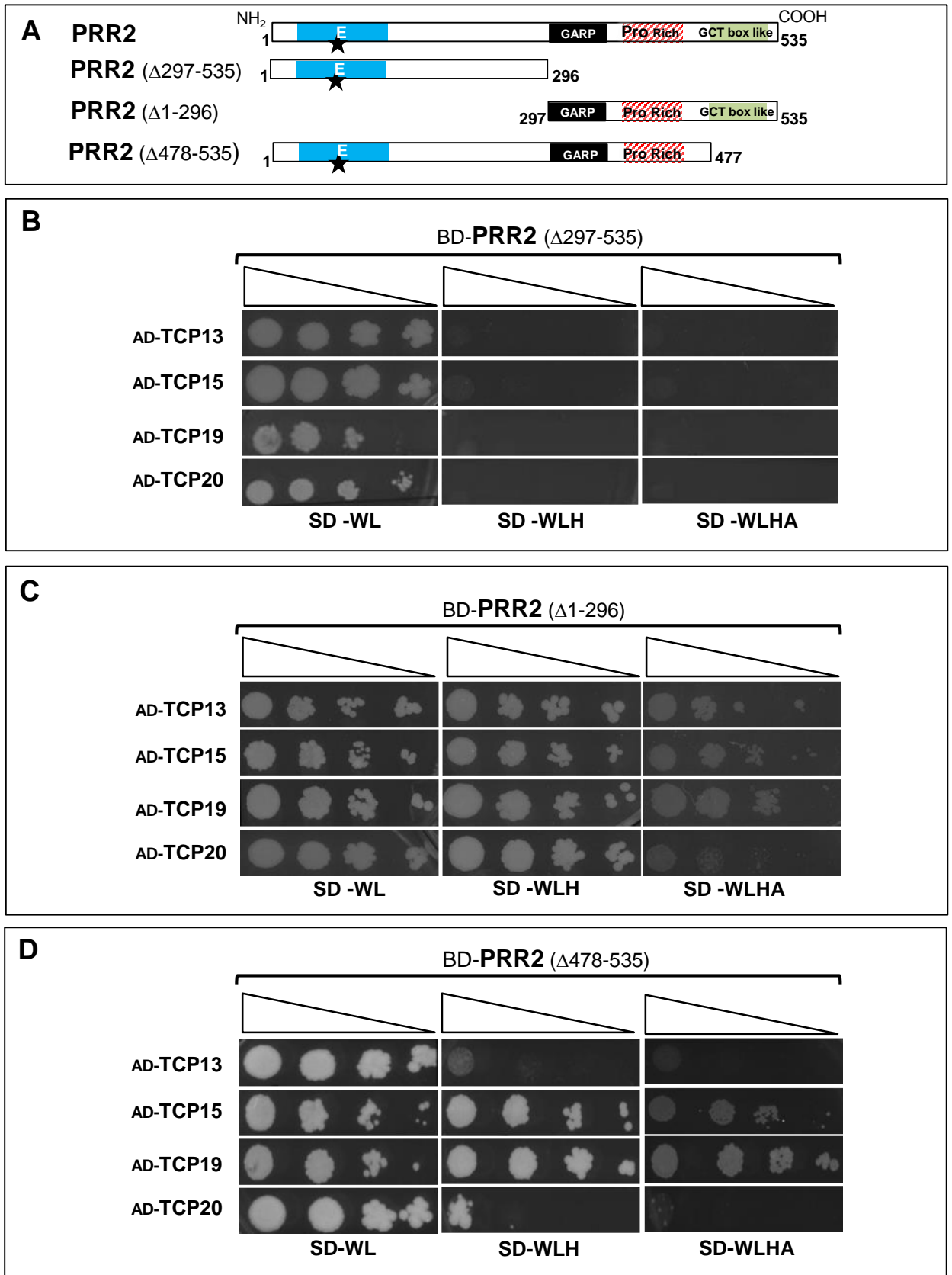

Figure 2

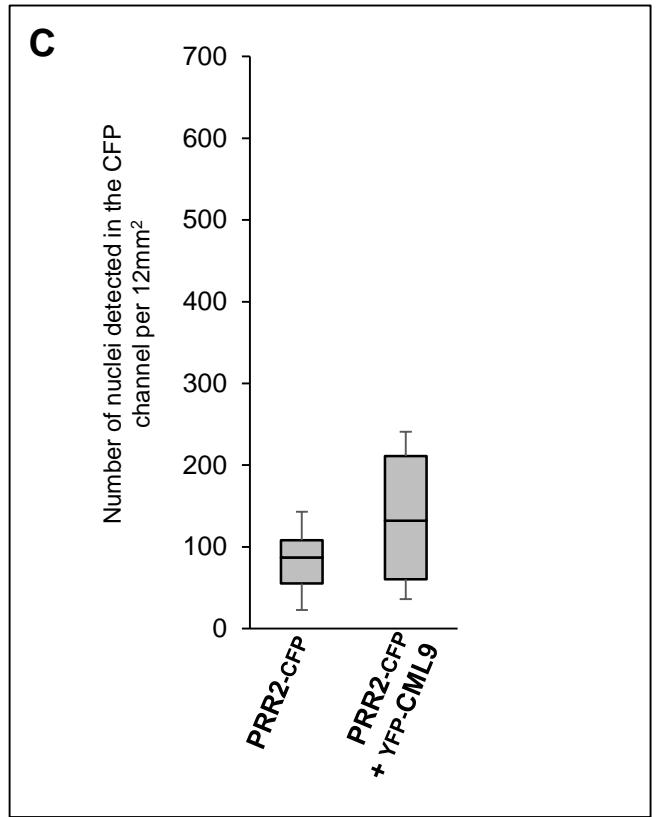
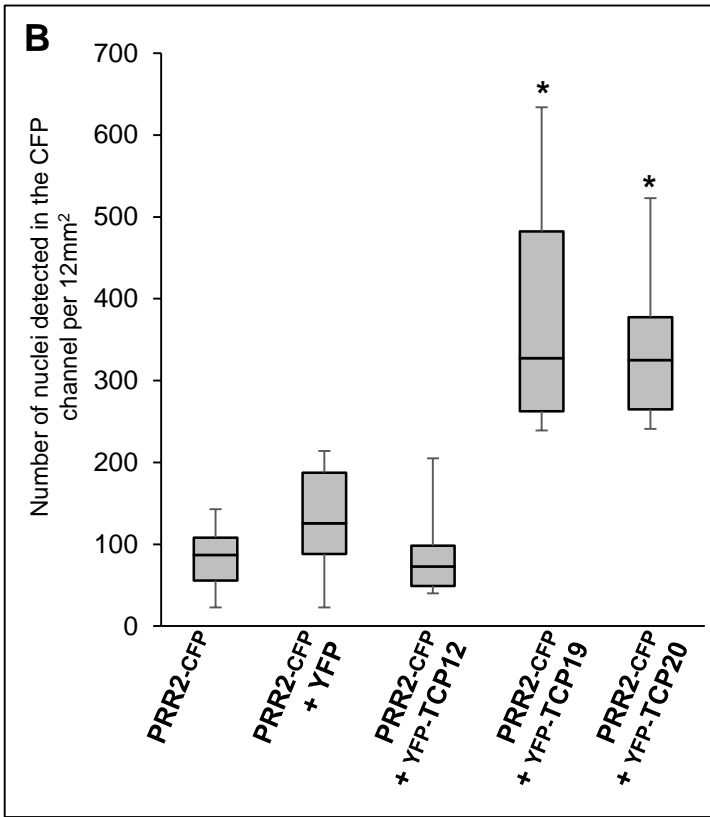
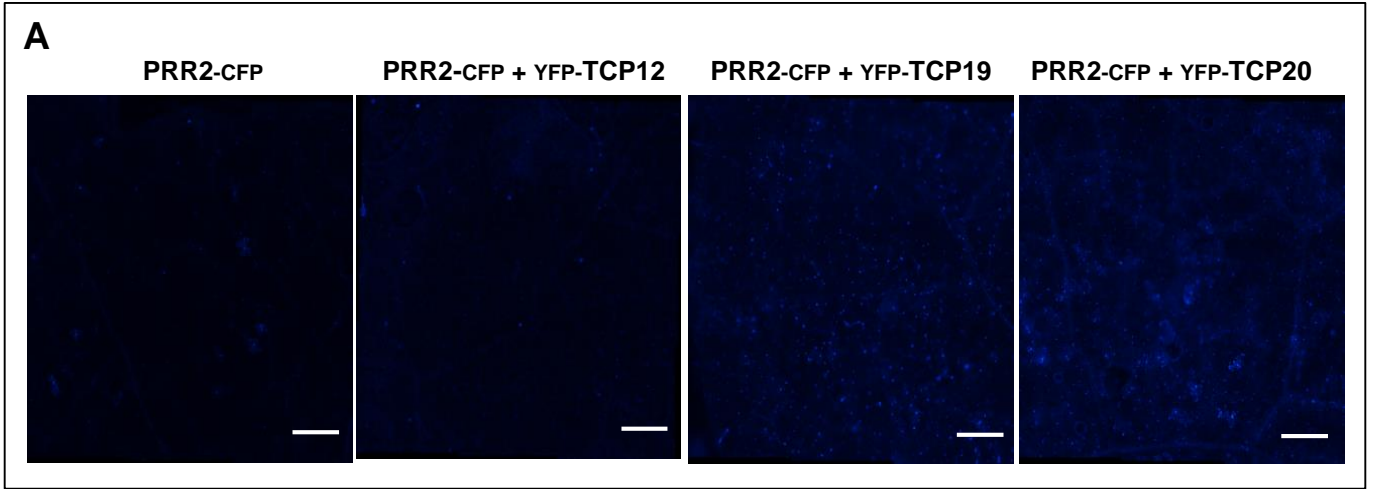
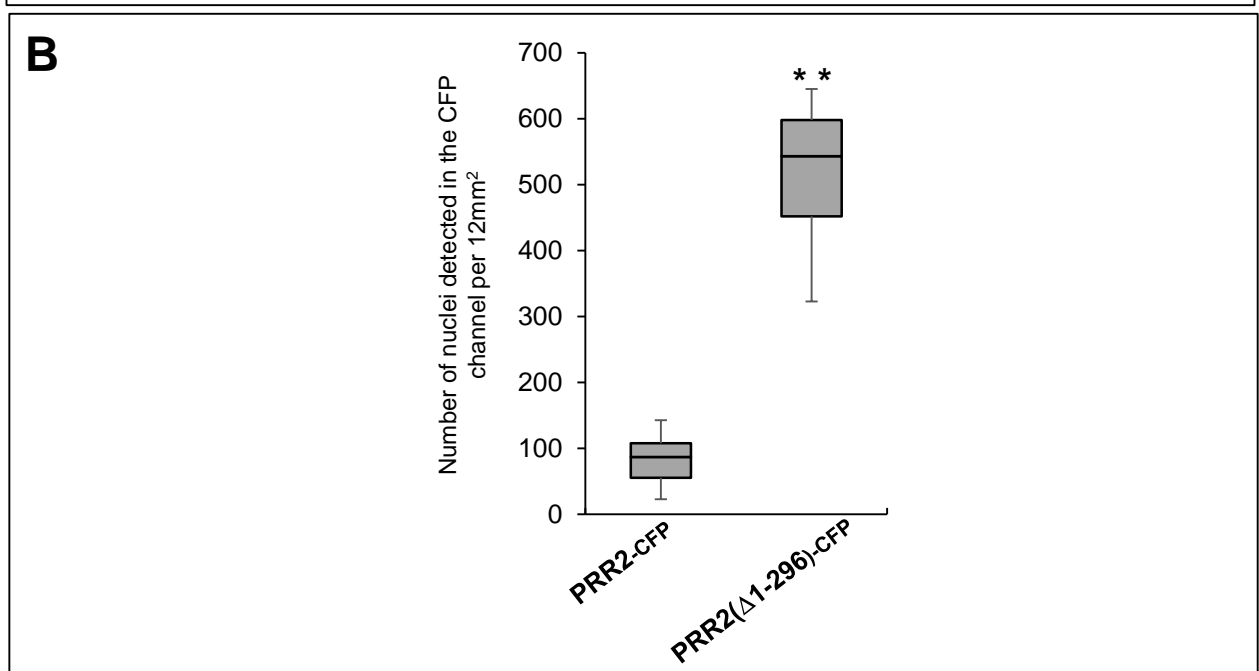
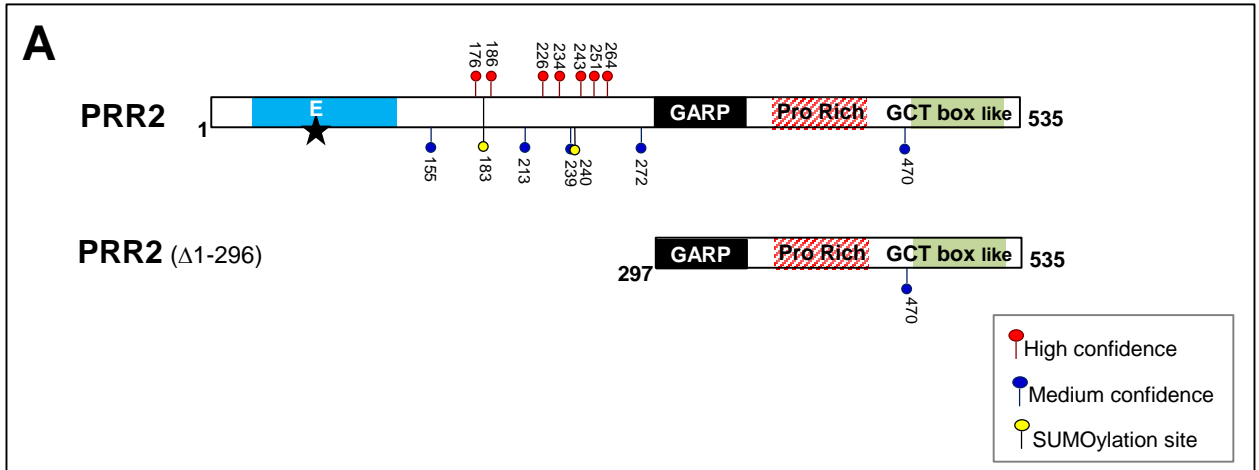
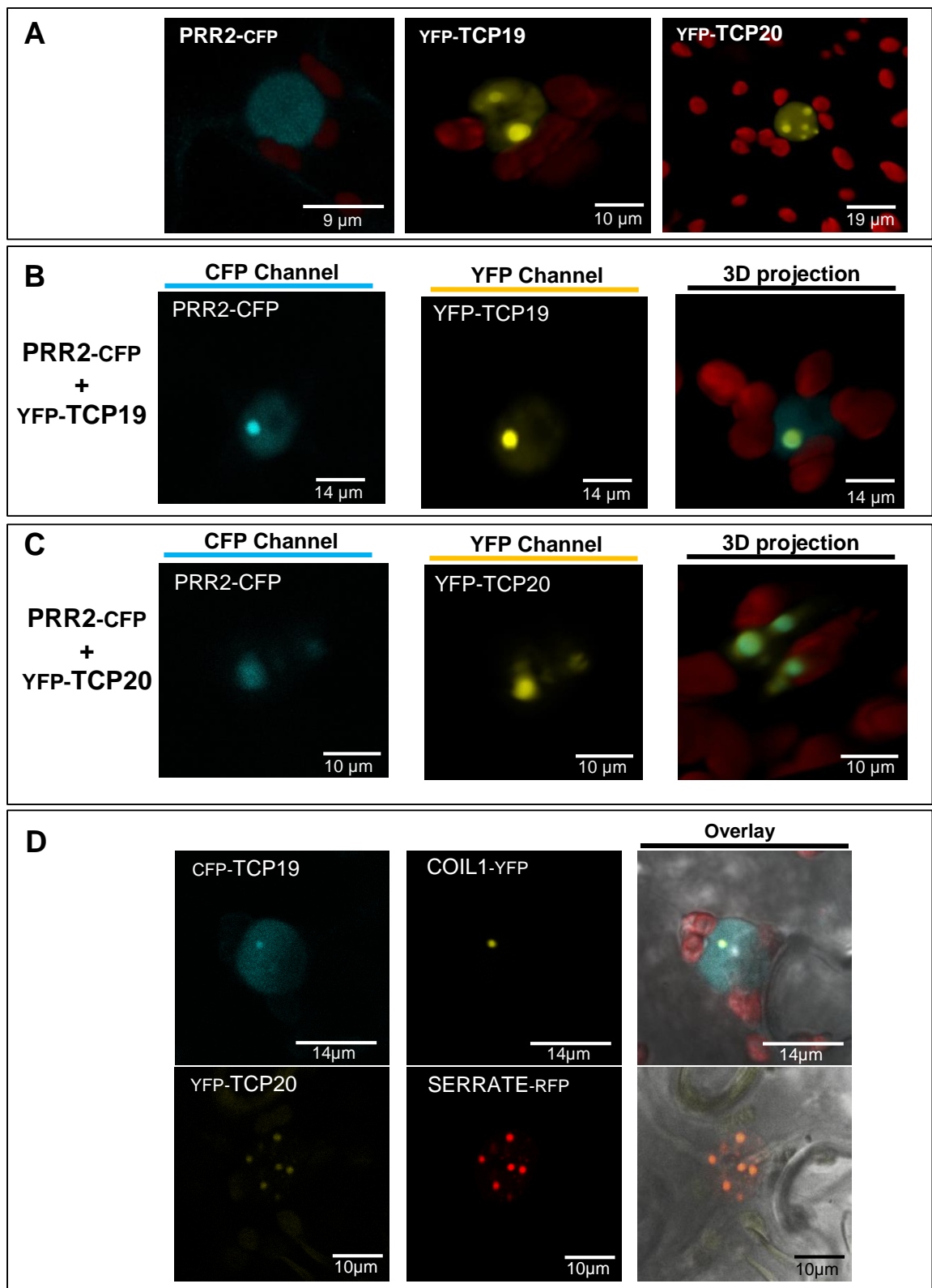

Figure 3





**Figure 4**



**Figure 5**