



**HAL**  
open science

## Using electrokinetic leakage to probe internal fouling of ultrafiltration membranes

Anthony Szymczyk, V Drevet, S. Liu, E Clavijo Rivera, L Villafaña López, M. Rabiller-Baudry, Estelle Couallier, M. Frappart

### ► To cite this version:

Anthony Szymczyk, V Drevet, S. Liu, E Clavijo Rivera, L Villafaña López, et al.. Using electrokinetic leakage to probe internal fouling of ultrafiltration membranes. Euromembrane, Jul 2018, Valencia, Spain. hal-02352407

**HAL Id: hal-02352407**

**<https://hal.science/hal-02352407>**

Submitted on 6 Nov 2019

**HAL** is a multi-disciplinary open access archive for the deposit and dissemination of scientific research documents, whether they are published or not. The documents may come from teaching and research institutions in France or abroad, or from public or private research centers.

L'archive ouverte pluridisciplinaire **HAL**, est destinée au dépôt et à la diffusion de documents scientifiques de niveau recherche, publiés ou non, émanant des établissements d'enseignement et de recherche français ou étrangers, des laboratoires publics ou privés.



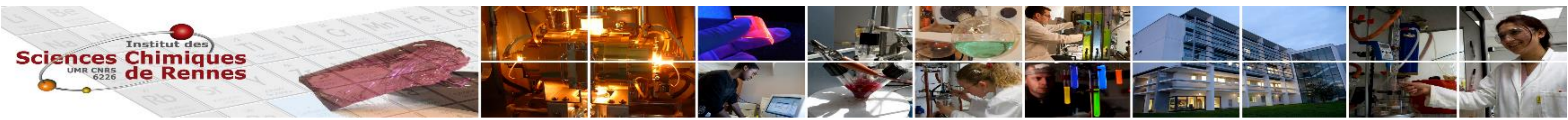

# Using electrokinetic leakage to probe internal fouling of ultrafiltration membranes

A. Szymczyk<sup>1\*</sup>, V. Drevet<sup>1</sup>, S. Liu<sup>2</sup>, E. Clavijo Rivera<sup>2</sup>, L. Villafaña López<sup>2</sup>, M. Rabiller-Baudry<sup>1</sup>, E. Couallier<sup>2</sup>, M. Frappart<sup>2</sup>

<sup>1</sup>Univ Rennes, CNRS, ISCR (Institut des Sciences Chimiques de Rennes) – UMR 6226, F-35000 Rennes, France

<sup>2</sup> CNRS, Université de Nantes, GEPEA, Université Bretagne Loire, Saint Nazaire, France

\*Contact: anthony.szymczyk@univ-rennes1.fr

## Introduction

The zeta potential is a fundamental feature providing information about the electrokinetic charge of a solid. It is very sensitive to any change in surface electrical properties, so it can serve as a probe in various studies in materials science (adsorption, fouling, ageing...). For macroscopic solids the zeta potential can be inferred from streaming potential or streaming current measurements. Most recent studies on the electrokinetic characterization of membranes dealt with measurements performed according to the so-called tangential mode, i.e. measurements performed along the membrane skin layer. The main reason is that the interpretation of transversal (i.e. through-pores) measurements can be quite complex in the case of asymmetric/composite membranes (Szymczyk *et al.*, 2001) and/or membranes with narrow pores (Fievet *et al.*, 2005). It has been shown, however, that complications in the interpretation of both tangential streaming potential (Yaroshchuk and Ribitsch, 2002) and streaming current (Yaroshchuk and Luxbacher, 2010; Szymczyk *et al.*, 2013) may arise when tangential measurements are carried out with membranes. In this work, we show that the electrokinetic leakage, i.e. the non-zero streaming current flowing through the membrane porous body when performing tangential electrokinetic measurements, can serve as a probe to detect internal fouling in porous membranes.

## Materials and Methods

### Membrane

Polyacrylonitrile (PAN) 500 kD (Orelis)

### Membrane fouling

Soaking in vegetable oil

### Solution for membrane characterization

KCl (0.001 M; pH 4.60 ± 0.05)

### Membrane characterization

Streaming current ( $I_s$ )

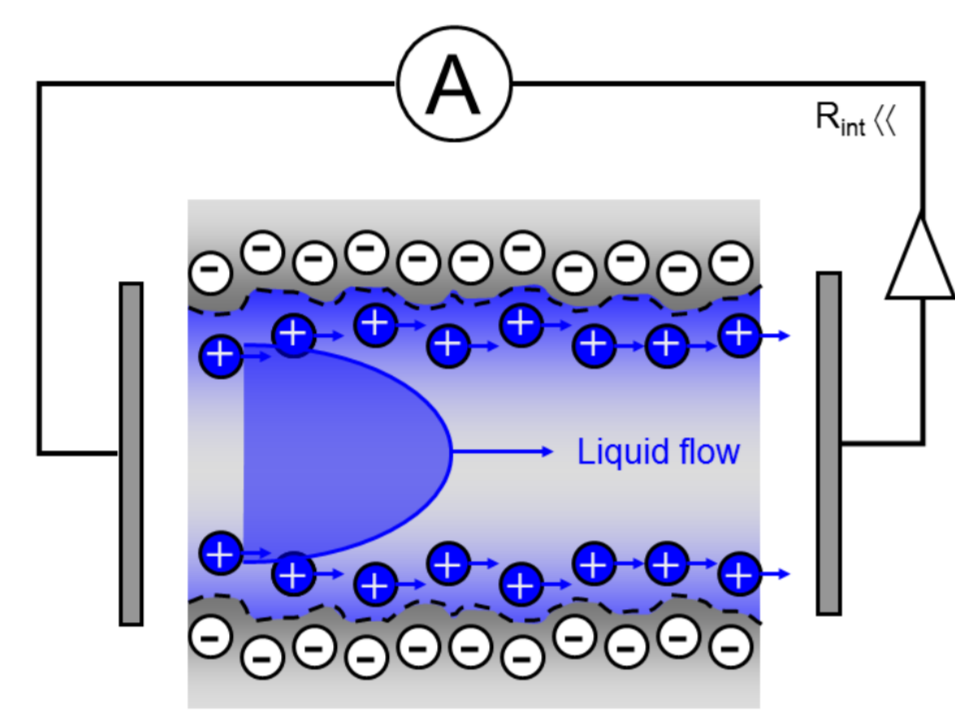

### For dense membranes

$$I_s = \frac{Wh_{ch}\epsilon_0\epsilon_r\Delta P}{\eta L} \zeta_{surf}$$

W: Sample width  
L: Sample length  
 $h_{ch}$ : Distance between membrane surfaces (gap)  
 $\Delta P$ : Applied pressure difference

$\epsilon_0$ : Vacuum permittivity  
 $\epsilon_r$ : Solution dielectric constant  
 $\eta$ : Solution dynamic viscosity  
 $\zeta_{surf}$ : Surface zeta potential

### For porous membranes

$$I_s = \frac{Wh_{ch}\epsilon_0\epsilon_r\Delta P}{\eta L} \zeta_{surf} + 2I_s^{pore}$$

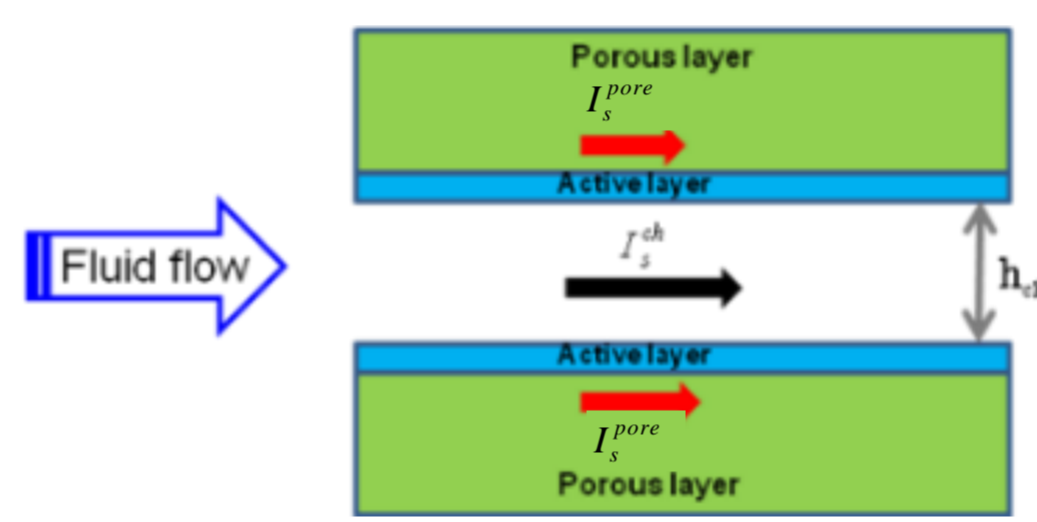

### Electrokinetic leakage

$$I_s^{tot} = I_s^{ch} + 2I_s^{pore} = \frac{Wh_{ch}\epsilon_0\epsilon_r\Delta P}{\eta L} \zeta_{surf} + \frac{2Wh^{eff}\epsilon_0\epsilon_r\Delta P}{\eta L} \zeta_{pore}$$

$I_s^{tot}$ : Total streaming current (= experimental signal)  
 $I_s^{ch}$ : Streaming current flowing between the membrane surfaces  
 $I_s^{pore}$ : Streaming current flowing through the porous structure of a single sample  
 $h^{eff}$ : Effective thickness on which the electrokinetic leakage occurs  
 $\zeta_{pore}$ : Pore zeta potential

## Results

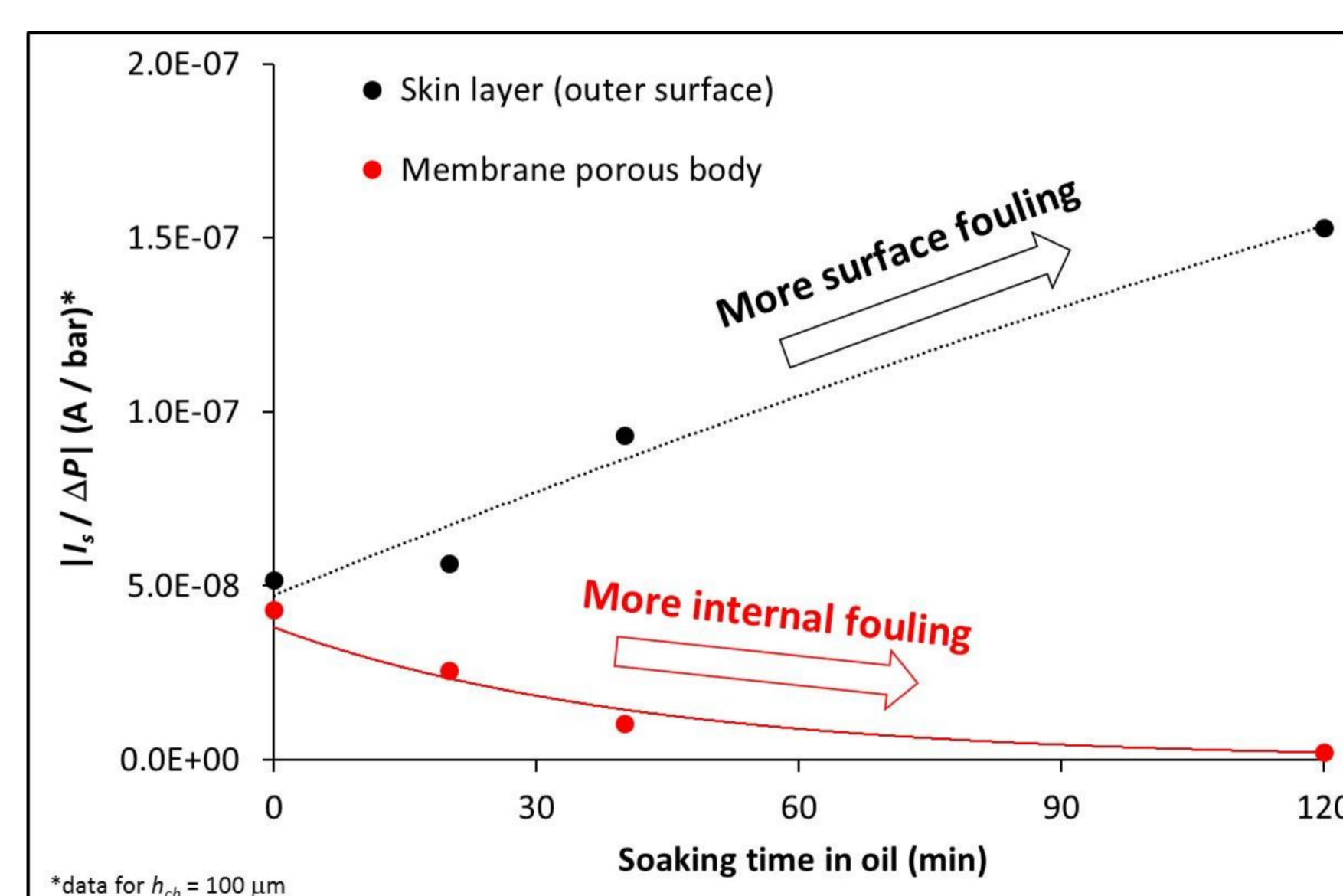
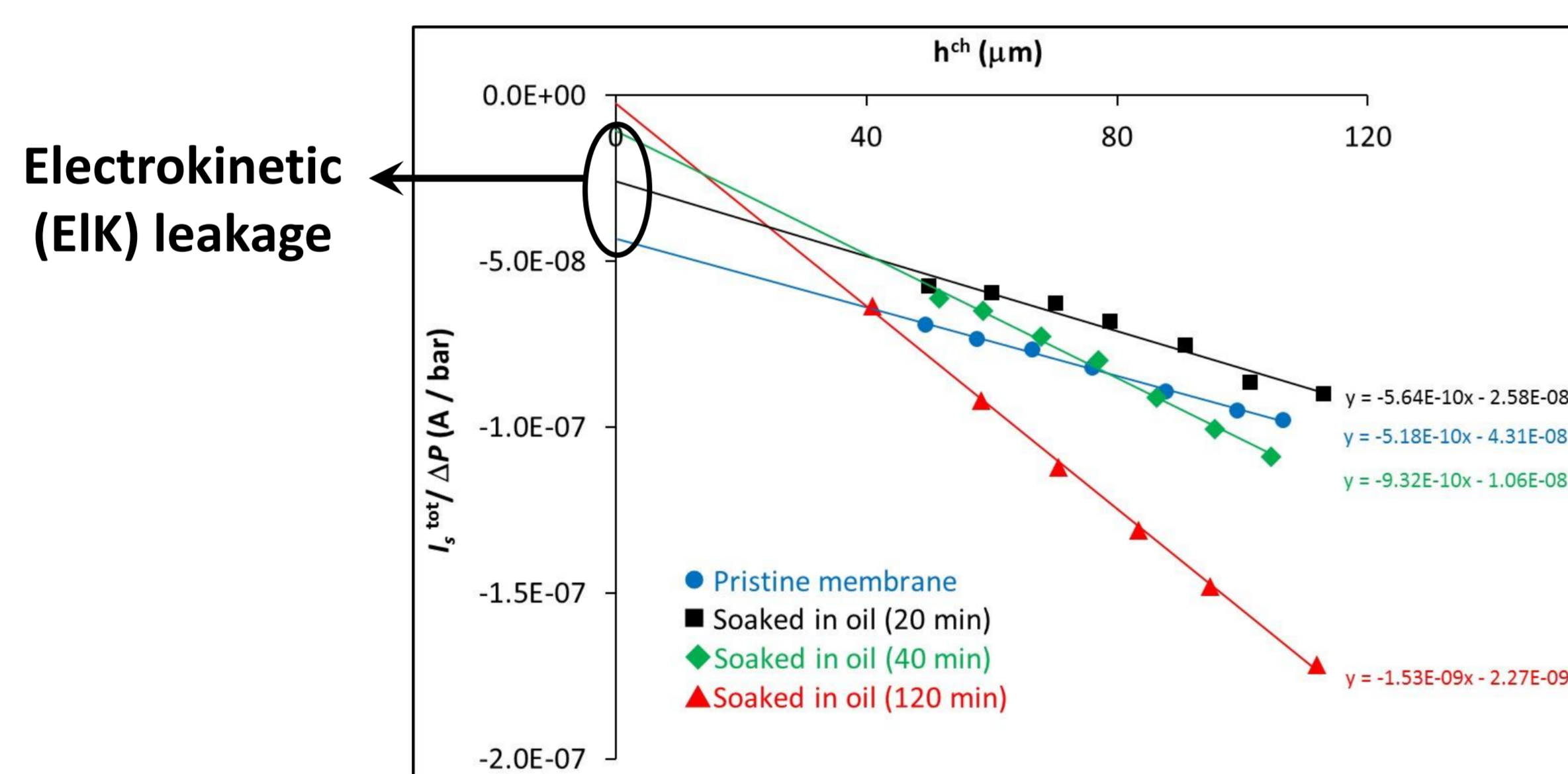

- Streaming current measurements performed by varying the distance between the membrane surfaces revealed significant electrokinetic (EIK) leakage through the pristine membranes.
- Neglecting EIK leakage may lead to misleading conclusions regarding the surface charge of membrane skin layers ( $I_s^{tot} \neq I_s^{ch}$ ).
- After soaking the membranes in oil, both  $I_s^{ch}$  and  $I_s^{pore}$  were affected → Tangential streaming current measurements allow highlighting both surface and internal fouling.
- Internal fouling by hydrophobic species can be put in evidence through the reduction of the EIK leakage (the ion-conductive pathways inside the membrane porous body are cut).

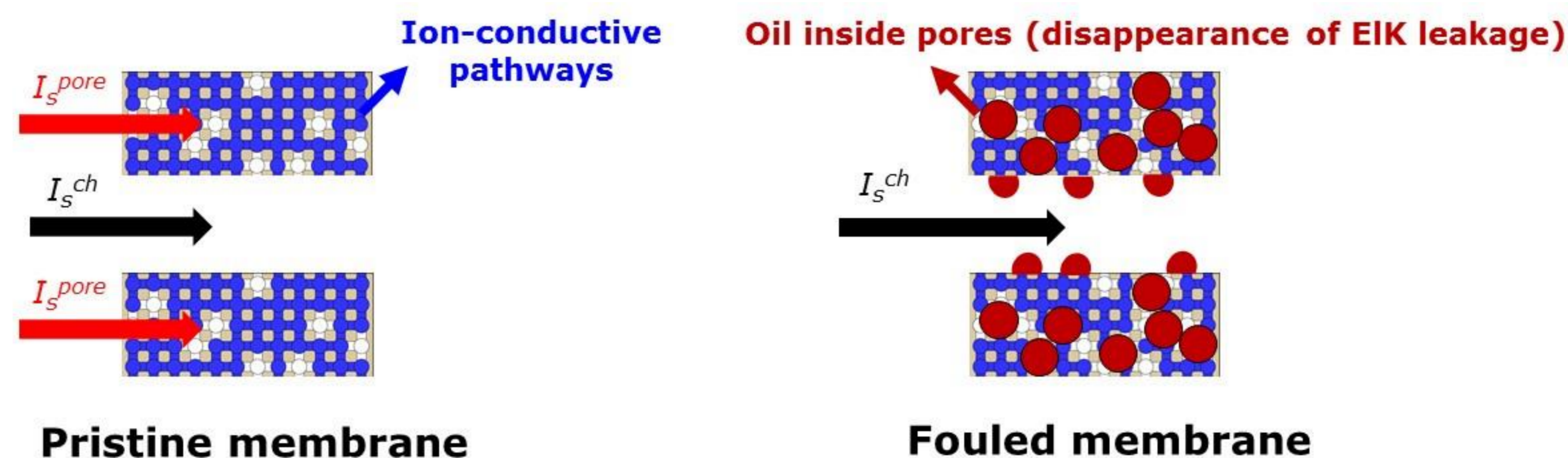

## References

- Fievet, P., Sbaï M. and Szymczyk A., *Analysis of the pressure-induced potential arising across selective multilayer membranes*, J. Membr. Sci. 264 (2005) 1-12.  
Szymczyk A., Labbez C., Fievet, P., Aoubiza, B. and Simon C., *Streaming potential through multilayer membranes*, AIChE J. 47 (2001) 2349-2358.  
Szymczyk A., Ibrahim Dirir Y., Picot M., Nicolas I. and Barrière F., *Advanced electrokinetic characterization of composite porous membranes*, J. Membr. Sci. 429 (2013) 44-51.  
Yaroshchuk A. and Ribitsch V., *Role of channel wall conductance in the determination of  $\zeta$ -potential from electrokinetic measurements*, Langmuir 18 (2002) 2036-2038.  
Yaroshchuk A. and Luxbacher T., *Interpretation of electrokinetic measurements with porous films: role of electric conductance and streaming current within porous structure*, Langmuir 26 (2010) 10882-10889.