



HAL
open science

Energy-aware Cross-level Model for Wireless Sensor Networks

Michel Bakni, Guillaume Terrasson, Octavian Curea, Alvaro Llaría, Jessye dos Santos

► **To cite this version:**

Michel Bakni, Guillaume Terrasson, Octavian Curea, Alvaro Llaría, Jessye dos Santos. Energy-aware Cross-level Model for Wireless Sensor Networks. SENSORCOMM2019, IARIA, Oct 2019, Nice, France. pp.46-51. hal-02335310

HAL Id: hal-02335310

<https://hal.science/hal-02335310v1>

Submitted on 28 Oct 2019

HAL is a multi-disciplinary open access archive for the deposit and dissemination of scientific research documents, whether they are published or not. The documents may come from teaching and research institutions in France or abroad, or from public or private research centers.

L'archive ouverte pluridisciplinaire **HAL**, est destinée au dépôt et à la diffusion de documents scientifiques de niveau recherche, publiés ou non, émanant des établissements d'enseignement et de recherche français ou étrangers, des laboratoires publics ou privés.

Energy-aware Cross-level Model for Wireless Sensor Networks

Michel Bakni, Guillaume Terrasson, Octavian Curea, Alvaro Llarria, Jessye Dos Santos

Univ. Bordeaux, ESTIA Institute of Technology

F-64210 Bidart, France

e-mail: {m.bakni, g.terrasson, o.curea, a.llarria, j.dossantos}@estia.fr

Abstract— In the design stage, Wireless Sensor Network developers generally need simulation tools to save both time and costs. These simulators require accurate models to precisely describe the network components and behaviours, such as energy consumption. Nevertheless, although the model has grown in complexity over last years, from layered-stack to cross-level, the energy aspects are not yet well implemented. In this paper, we suggest an energy-aware cross-level model for Wireless Sensor Networks. Our modelling approach allows for parameters that belong to different levels to interact with each other and to analyse their impact on energy consumption. To validate this approach, the energy-aware cross-level model for network radiofrequency activities is first provided. The results obtained using suggested scenarios are compared with those collected from a well-known simulator: NS2. Finally, the usefulness of our model in Wireless Sensor Network design process is demonstrated thanks to a case study aimed at comparing and selecting the most energy-efficient wireless link protocol.

Keywords-Energy-aware design; Cross-level; Energy modelling; Wireless Sensor Networks.

I. INTRODUCTION

A Wireless Sensor Network (WSN) is a set of nodes, which embed sensors coupled with processing units and wireless communication devices. This kind of network is used to monitor physical phenomena in the deployment area or to trace targets moving inside it. Thanks to battery-powered and wireless connectivity features, WSNs are both highly flexible and scalable. These two characteristics make WSNs a technology that provides innovative applications in a wide variety of domains, such as healthcare, industry, and agriculture [1].

Nevertheless, node energy resources are strictly limited, making the power-aware design of WSNs a major research issue, whose relevance has increased in recent years [2]. In this regard, at the very early stages of the design process, engineers and researchers involved in the development of WSN applications must take the right decisions in terms of energy efficiency and also consider overall application performances. Usually, simulators and emulators are used to accomplish this task.

The scientific literature review reveals a wide variety of simulators generally designed for a specific-level such as network or node levels. However, this review shows that there is a lack of analysis tools dedicated to the early design stages, especially from a power awareness point of view. For example, there is no model that is able to show how a given parameter impacts energy consumption, not only from a

specific-level perspective but from a multilevel one as well [3].

In this context, the work presented defines an energy-aware cross-level model for WSNs which tries to mitigate the limitations mentioned above. The suggested model is applied to the radiofrequency (RF) activities of the network, a vital part of the node that is generally responsible for a high-energy consumption in WSN applications [4]. The goal of our model is to accurately estimate RF module consumption based on cross-level parameter impacts.

This paper is organised as follows. Section II provides an overview of the development of WSN models and the associated simulators. In Section III, a global description of the proposed cross-level approach together with its application to WSN RF activities is provided. The first results using the implemented energy-aware model are presented and discussed in Sections IV and V. Finally, Section VI concludes this paper.

II. WSN MODELLING AND SIMULATION

To better address the modelling issue, a review of the evolution of WSN models is first provided. Then, for WSN simulators based on these models, an energy-aware level-based classification is introduced.

A. WSN Models: from Layered-stack to Cross-level Design

Classical data network models, such as Open Systems Interconnection (OSI), propose a design approach consisting of a set of layers that are stacked together. In a layered-stack model, the layers are separated according to their functionality. Every layer offers interfaces only towards adjacent layers in the stack [5]. However, in WSNs, parameters from different layers interact with each other, and services are provided across the stack layers rather than a specific layer. Thus, the traditional stack-layered model is difficult to adapt to the requirements of this kind of network [6].

Several years ago, many works dealt with the modelling issue, developing various solutions. In [5], the authors propose a modelling approach based on a cross-layer design. This approach supports adaptivity and optimisation across multiple layers of the protocol stack. A similar cross-layered model is proposed in [7]. Moreover, security considerations from a cross-layer point of view are added to this cross-layered model in [8].

Another strategy is to propose the “tier” or “level” concept [9], where a level represents a group of parameters that belong to different functions and features of WSNs, and not only to the network model. In parallel to the previous approaches, the solution described in [10] groups the model

layers into two levels. The first is mainly concerned with non-physical parameters related to software and the application. The second is dedicated to hardware where the protocols are implemented, mainly routing and linking, as well as sensors and RF unit parameters.

Subsequently, different evolutions were proposed to develop a cross-level model following the multi-level approach. This led to the development of a new approach to model WSNs, extending the traditional layered-stack model to include not only software and hardware levels that make up the nodes, but also parameters from the surrounding environment. In this way, a wireless medium level was attached to the model in [11] and [12]. In [13], a description of how the multiple-level model is used to design and develop WSN from a cross-level perspective is also carried out.

Nevertheless, as demonstrated in [13], not all the proposed approaches are actually employed in an effective cross-level manner. Moreover, as mentioned above, the energy aspect of WSNs is not always well implemented, despite this being a crucial issue in WSN design.

B. WSN Simulators: a Level-based Overview

In general, WSNs simulators are dedicated to a specific level of abstraction and are built over the previously discussed models. Thus, they focus on simulating parameters related to one particular level [2]. A parameter is a numeric value describing one property of a given level, such as power levels or bit rate.

For example, Network simulator 2 (NS2) [14] is oriented to network protocol simulation and provides poor support for hardware. On the contrary, TOSSIM [15] emulates hardware in detail, but it provides an abstract perspective of network protocols. Furthermore, there are multi-level simulators. In this case, the simulator uses parameters belonging to different levels at the same time. For instance, Jsim [16] is a multi-level WSN simulator because it simulates both environment and network parameters. Finally, some simulators are described as cross-level, because they provide the ability for parameters belonging to different levels to interact with each other. COOJA [17] is an example of this category of simulators.

All the previously mentioned simulators are non-energy-oriented. This does not mean they cannot simulate energy aspects, but rather they were not built for this purpose. Based on this, another classification can be proposed, as illustrated in Figure 1. Simulators are first divided based on energy with two main branches, energy-oriented and non-energy-oriented simulators [3]. Then, a level-based classification is added.

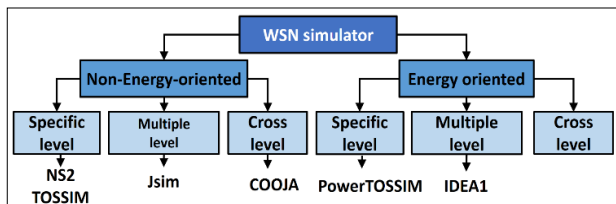

Figure 1. Energy-aware level-based classification for WSN simulators.

Overviewing the energy-oriented simulators, on the one hand, PowerTOSSIM [18] is an energy-oriented TOSSIM extension dedicated to the emulation of energy in hardware. On the other hand, IDEA1 [19] is an example of an energy-oriented multi-level simulator. IDEA1 divides the network into three abstract levels: the environment, the node, and the wireless medium. Although the simulator allows cross-level interaction for some parameters, this feature is not fully supported, and there are still parameters that are not treated in a cross-level manner, such as the environment parameters.

This review shows that many non-energy-oriented multi or cross-level models and simulators of WSNs have been proposed. However, from an energy point of view, the cross-level approach is not fully adopted. Therefore, with existing simulators, it is difficult to analyse the impact of parameters that belong to different levels on both the overall node energy consumption and WSN lifetime.

III. CROSS-LEVEL ENERGY MODEL

In this section, to address the problems described above, we propose a model for WSNs that is both energy-aware and cross-level.

A. Global Model

In our model, the implementation of the cross-level concept allows parameters from different levels to interact with each other affecting the performances of WSNs. In this work, we are only concerned with the impact of the parameters on energy performance such as network lifetime and node autonomy. Figure 2 provides an overview of the proposed model.

The model's levels can be described as follows:

- The Use case Level (UL) is the most abstract level of the model. It is related to the design stage of the WSN application. Parameters, such as frequency of the pattern F_p of the nodes, to be defined later, or payload length reside in this level.

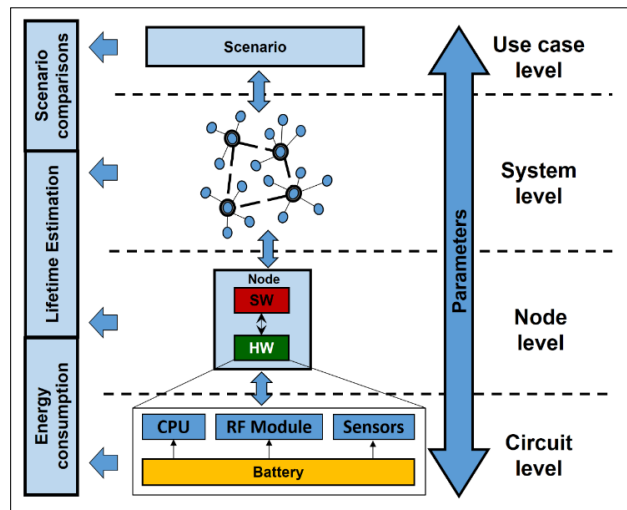

Figure 2. The Proposed Cross-level model for Wireless Sensor Networks.

- The System Level (SL) reflects a topological point of view of the network. It focuses on how high-level protocols and algorithms affect WSN performances. Parameters related to the network topology, like the distance between nodes or high-level protocols headers, belong to this level.
- The Node Level (NL) concerns the interaction between software (node operating system) and onboard hardware (RF circuit). As illustrated in Figure 3, the parameters related to the link protocol, such as the bit rate and the link layer header fit in this level, as well as the parameters related to channel access or acknowledgment process.
- The Circuit Level (CL) is particularly used to describe node hardware. Modelling and description of electronic circuits reside in this level. It includes RF module, sensors, CPU and battery as well as hardware-specific parameters, such as power level or supply voltage.

Consequently, in this model, the higher the level is, the more abstract and general the parameters are. For example, parameters belonging to the UL are related to the scenario description and theoretically fit into any WSN application. On the other hand, CL parameters are very specific and describe only particular electronic circuits.

As illustrated in Figure 2, the use of the cross-level feature enables not only energy consumption of the nodes or the system's lifetime to be estimated, but also provides a basis for different scenario comparisons.

B. Energy-aware Model Applied to RF Activities

The proposed model is first applied to describe RF activities in a WSN. Based on the afore mentioned classification, the parameters related to RF activities are categorised as illustrated in Figure 3. Note that the colour of each parameter corresponds to its parent level.

In the first stage, the total number of bits to send is calculated. This includes the payload (UL) created by the sensors or other applications that generate data on the node, as well as high-level protocol headers (SL) and the link layer protocol header (NL).

After this, the total amount of data is confronted against the fragmentation threshold (NL) identified by the wireless link protocol. If fragmentation is needed, the process will take place in this stage, and will result in two or more data frames. Next, the preamble (NL) is added to each data frame. Then, the length of each frame is calculated in terms of seconds, thanks to the bitrate(s) (CL) provided by the selected chipset.

The next step is to build the energy consumption pattern for the node's RF activities. In our approach, we assume the energy consumption in each node takes place based on a repeated pattern. The pattern is defined as a set of sequenced activities or phases with their corresponding power levels. In this context, the frequency of the pattern F_p (UL) corresponds to the ratio between the number of occurrences of the pattern and the considered simulation time.

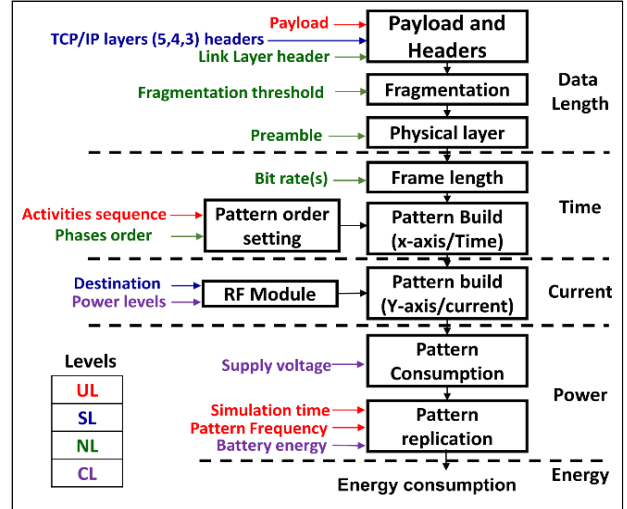

Figure 3. An energy-aware cross-level model for RF activities.

Then, to build this RF consumption pattern, activities sequence (UL) and phases order (NL) are to be considered. The activity sequence helps to specify the actions taking place, i.e. sending or receiving frames, while the link protocol defines the phases and their order within each activity. For example, in the sending activity, the order of phases is: accessing the channel (ph_{acc}), exchanging data frames (ph_{exch}) and then waiting for acknowledgment (ph_{ack}).

After that, the sequence of activities is to be matched with the power levels (CL) provided by the RF module datasheet. This includes the consideration of the distance (SL) that has a direct impact on the power level of the sending activity. Then, the energy consumed is calculated.

In the last stage, the total simulation time (UL), the frequency of the pattern F_p (UL), as well as the initial amount of the energy stored in the battery (CL) are considered in our model to estimate the system's lifetime.

IV. MODEL COMPARISON WITH NS2

A. Scenario Definition

Simulation scenarios are suggested to compare the results obtained from the proposed model with those of a well-known simulator, namely NS2. These scenarios take place in an open area measuring 25x25 m². Within this area, there are two wireless nodes, 10m apart, named Node A and Node B. Periodically, Node A sends a fixed-length payload to Node B through the wireless medium using its RF module. As soon as Node B receives the payload, it replies by sending the received payload to Node A through the wireless medium. Node A and Node B use the same protocol stack.

Each node applies a TCP/IP network model. The implementation of the protocols starts at the network layer where Internet Protocol version 4 (IPv4) has been chosen. The Internet Control Message Protocol (ICMP), which is an integral part of IPv4, is employed to create echo messages. Consequently, whenever the IPv4 module receives a data packet, it sends the same data back to the original source. In all scenarios, the length of IPv4 and ICMP headers are 20 and

4 bytes respectively, as defined by the standards. Table I displays the scenario settings.

Next, the link layer parameters are set. We decided to implement two wireless link protocols. 802.11a is used in the first set of scenarios, while 802.15.4 is applied in the second set. The energy specification for the 802.11a RF module is derived from an implementation of a chipset named HDG204 (H&D wireless). For 802.15.4, the CC2420 transceiver (Texas Instruments) is selected. Table II shows the settings of the two wireless link protocols.

For each simulation, the considered time used to calculate energy consumption is 100 seconds, and it begins after initialising the nodes. For each protocol, three different values of F_p : 0.1, 1 and 2 Hz, and ten values for the payload length ranging between 10 to 100 bytes are used. Each scenario requires a combination of the three parameters mentioned above. As a result, there are 30 scenarios to be run for each wireless link protocol. These scenarios are configured both in NS2 and in the proposed model implemented in Matlab aimed at comparing the results.

B. Results and Discussion

The obtained results are the energy consumed by different activities of the RF module. These activities are categorised into 4 phases:

- Access phase (ph_{acc}): RF module tries to access the wireless channel.
- Exchange phase (ph_{exch}): RF module sends or receives data frames.
- Acknowledge phase (ph_{ack}): RF module sends or receives acknowledgment frames.
- Complementary phase (ph_{com}): The RF module is in sleep state.

In these phases, the cross-level interaction between parameters takes place, i.e. the energy consumed in each phase is the result of interplay between parameters related to different levels. For example, in the exchange phase, the consumed energy is a function of the header lengths, payload length and bit rate, which belongs to the following levels: UL, SL and NL respectively.

TABLE I. GENERAL SETTINGS FOR THE PROPOSED SCENARIOS

Parameter	Value
Number of the nodes	2
Node positions	(10,10), (10,20) [m]
Scenario duration T_{sc}	100 [s]
Pattern Frequency F_p	0.1, 1, 2 [Hz]
Payload length	10, 20, ..., 100 [Byte]
Link protocol	802.11a, 802.15.4

TABLE II. WIRELESS LINK PROTOCOLS SETTINGS

Parameter	802.11a (HDG204)	802.15.4 (CC2420)
Bitrate [bps]	12 M	250 K
Carrier Sense Mechanism	Pure CSMA/CA	CCA-ED
Transmitter power [mW]	725	52
Receiver Power [mW]	220	59
Sleep Power [mW]	0.2	0.06

The results obtained by implementing the previously described scenarios in NS2 and Matlab using our model can be found in Table III. The upper part shows the obtained results from 802.11a and the lower part for 802.15.4. Each part is further divided into two subparts, corresponding to scenarios with 10 and 100 bytes for the payload length respectively. Figure 4 shows the energy consumption patterns of Node B, extracted from our model, for the two protocols when the payload length is 100 bytes. Compared to NodeB, Node A has the same activities, thus, it has an identical energy consumption.

For the two protocols, when comparing results obtained from NS2 and our proposed model, the following differences and similarities can be found. The energy consumed in ph_{acc} or ph_{ack} is identical and there is a slight difference in the energy consumed in ph_{com} . In ph_{exch} , the difference is notable but fix and this is due to different interpretations of the link protocol specifications. For example, in our model, the ICMP header is considered to be part of the data packet, contrary to NS2 where this header is added to the data packet later on.

Figure 5 shows the relative errors between the results obtained from NS2 and those obtained from the proposed model. The left side of the figure is dedicated to 802.11a and the right side to 802.15.4. Different values of F_p are displayed, namely 0.1, 1, and 2 Hz. For each of these values, a set of corresponding errors is provided, each of which is also related to a simulation where the payload length is 10, 50, or 100 bytes.

TABLE III. ENERGY CONSUMPTION OF THE PHASES IN DIFFERENT SCENARIOS FOR NODE B ($F_p = 1$ Hz)

Simulation	The consumed energy by phase [μ J]				
	ph_{acc}	ph_{exch}	ph_{ack}	ph_{com}	Total
802.11a					
10 Bytes					
Matlab	51.03	50.08	23.63	199.959	324.69
NS2	51.03	55.76	23.63	199.950	330.37
100 Bytes					
Matlab	51.03	106.79	23.63	199.935	381.38
NS2	51.03	112.46	23.63	199.927	387.04
802.15.4					
10 Bytes					
Matlab	18.89	145.73	39.07	59.78	263.47
NS2	18.88	152.84	39.07	59.78	270.47
100 Bytes					
Matlab	18.89	465.37	39.07	59.44	582.77
NS2	18.88	472.42	39.07	59.45	589.82

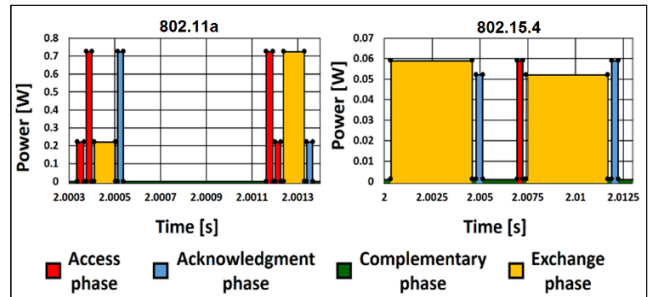

Figure 4. Energy consumption patterns for different wireless link protocols (Node B, Payload length = 100 Bytes, $F_p = 1$ Hz).

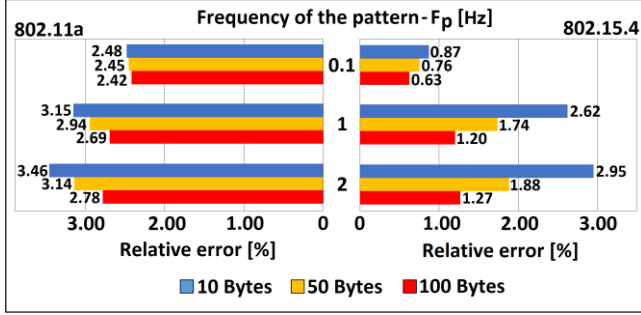

Figure 5. Relative error between the proposed model and NS2.

In all the simulation results, the relative errors obtained from 802.11a are greater than those of the corresponding scenarios of 802.15.4. This difference can be explained by unplanned and non-periodic radio activities that appear periodically in NS2 802.11a simulations. These activities have a fixed duration regardless of F_p and the payload length. Each of these activities appears as a single pulse of transmission or reception causing an additional energy consumption around of 5 μ J and 2 μ J respectively.

Finally, as illustrated in Figure 5, the value of the relative error between NS2 and the proposed model did not exceed 3.5%. Based on this, we can consider the proposed model is validated with NS2. Although not shown in this scenario, our proposed WSN model also allows adding energy consumption phases with other hardware on the node, such as CPU or sensors. As a result, an accurate pattern can be constructed precisely representing the real consumption of the node contrary to NS2 that has poor support for hardware, as mentioned above.

V. APPLICATION OF THE MODEL: A CASE STUDY

To demonstrate the usefulness of the proposed model, the previous scenarios, suggested in Section IV.A, are used to compare wireless link protocol performance in terms of energy consumption. The interaction between two parameters with regard to energy consumption is observed. These two parameters are the pattern frequency F_p and the payload length.

Figure 6 presents the difference, in Joules, between the energies ($E_{pat802.11a} - E_{pat802.15.4}$) consumed by the two link protocols respectively. There are three distinguishable situations:

- The red curve: this represents the equal-energy boundary, i.e. for the scenarios that are positioned on the curve, the two protocols consume the same amount of energy.
- The area above the curve (cyan): in this area, 802.11a is more energy-efficient than 802.15.4. For all the scenarios that are positioned inside this area, using 802.11a as the wireless link protocol is recommended from an energy point of view.

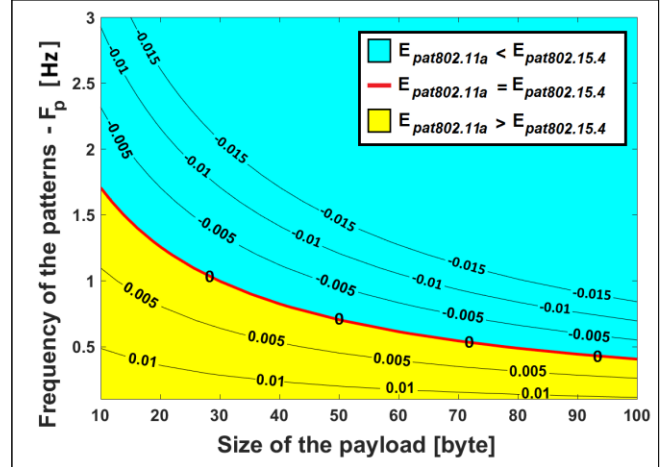

Figure 6. The Equal-energy curve of the 802.11a and 802.15.4 in the proposed scenarios.

- The area below the curve (yellow): in this area, 802.15.4 is more energy-efficient than 802.11a. For all the scenarios that are positioned inside this area, using 802.15.4 as the wireless link protocol is recommended.

As illustrated in Figure 6, when F_p is 2 Hz, using 802.11a is more efficient in terms of energy consumption. On the contrary, when F_p is 0.1 Hz, the use of 802.15.4 is more energy efficient. In the case where F_p is 1 Hz, the choice is a function of the payload size. If it is less than 30 bytes, the use of 802.15.4 is more efficient. Conversely, when the payload size is greater than 30 bytes, using 802.11a is more effective from an energy perspective.

Finally, this case study demonstrates how the proposed model could be used in the early design stage, as a tool to select, for example, the most energy-efficient protocol for a given case study. Moreover, it shows the energy-aware aspect of our model, namely, its ability to observe how a given parameter could impact energy consumption.

VI. CONCLUSION

This paper has presented the principles of a cross-level energy model for power-aware WSN design, mainly aimed at WSN designers. First, the model was implemented to describe the RF activities and the obtained results were compared with NS2. This comparison showed a relative error percentage below 3.5% for the considered scenarios. The model's usefulness has also been illustrated by comparing two wireless link protocol from an energy point of view, using a basic case study.

Although the results are promising, other hardware activities, such as the CPU and sensors, are to be implemented in the proposed model as well. Furthermore, for future work, a simulation tool which implements the complete cross-level energy-aware model is also to be developed. This tool will first be validated using more complex scenarios that cover, for example, a number of different network topologies with more than two nodes. Then, the results obtained from this tool will be also

compared to experimental case studies to demonstrate the accuracy of our cross-level approach.

ACKNOWLEDGMENT

The work presented in this paper has been financially supported by the New Aquitaine Regional Council, Bordeaux, France (as part of the Call for 2016 Project funds), within the framework of the OUDINI research project.

REFERENCES

- [1] J. Yick, M. Biswanath, and G. Dipak, "Wireless sensor network survey," *Computer networks*, Elsevier, pp. 2292-2330, vol. 52, no. 12, Aug. 2008, doi: 10.1016/j.comnet.2008.04.002.
- [2] R. Chéour, M. W. Jmal, O. Kanoun, and M. Abid, "Evaluation of simulator tools and power-aware scheduling model for wireless sensor networks," *IET Computers & Digital Techniques*, vol. 11, pp. 173-182, Aug. 2017, doi: 10.1049/iet-cdt.2017.0003.
- [3] J. Haase, J. M. Molina, and D. Dietrich, "Power-aware system design of wireless sensor networks: Power estimation and power profiling strategies," *IEEE Trans. on Industrial Informatics*, vol. 7, pp. 601-613, 2011, doi: 10.1109/TII.2011.2166793.
- [4] G. Terrasson, R. Briand, S. Basrou, V. Dupé, and O. Arrijuira, "Energy Model for the Design of Ultra-Low Power Nodes for Wireless Sensor Networks", *Procedia Chemistry*, Vol. 1, Issue 1, pp. 1195-1198, 2009, doi 10.1016/j.proche.2009.07.298.
- [5] H. Zimmermann, "OSI Reference Model - The ISO Model of Architecture for Open Systems Interconnection," in *IEEE Trans. on Communications*, vol. 28, no. 4, pp. 425-432, April 1980, doi: 10.1109/TCOM.1980.1094702.
- [6] A. J. Goldsmith and S. B. Wicker, "Design challenges for energy-constrained ad hoc wireless networks," *IEEE Wireless Communications*, vol. 9, pp. 8-27, Aug. 2002, doi: 10.1109/MWC.2002.1028874.
- [7] I. F. Akyildiz, W. Su, Y. Sankarasubramaniam, and E. Cayirci, "Wireless sensor networks: a survey," *Computer Networks*, vol. 38, no. 4, pp. 393-422, Mar. 2002, doi: 10.1016/S1389-1286(01)00302-4.
- [8] W. Charfi, M. Masmoudi, and F. Derbel, "A layered model for wireless sensor networks," *Proc. of 6th International Multi-Conference on Systems, Signals and Devices*, IEEE, Mar. 2009, pp. 1-5, doi: 10.1109/SSD.2009.4956693.
- [9] E. Egea-López, J. Vales-Alonso, A. S. Martínez-Sala, P. Pavón-Mariño, and J. García-Haro, "Simulation tools for wireless sensor networks," *International Symposium on Performance Evaluation of Computer and Telecommunication Systems (SPECTS05)*, Society for Modeling & Simulation International, Jul. 2005, pp. 1-8, ISBN: 9781622763504.
- [10] M. Kuorilehto, M. Kohvakka, M. Hännikäinen, and T. D. Hämäläinen, "High abstraction level design and implementation framework for wireless sensor networks," *International Workshop on Embedded Computer Systems: Architectures, Modeling, and Simulation (SAMOS 2005)*, Lecture Notes in Computer Science Springer, Jul. 2005, pp. 384-393, doi:10.1007/11512622_41.
- [11] M. Korkalainen, M. Sallinen, N. Kärkkäinen, and P. Tukeya, "Survey of wireless sensor networks simulation tools for demanding applications," *2009 Fifth International Conference on Networking and Services*, IEEE, Apr. 2009, pp. 102-106, doi: 10.1109/ICNS.2009.75.
- [12] W. Du, D. Navarro, F. Mieyeville, and F. Gaffiot, "Towards a taxonomy of simulation tools for wireless sensor networks," *Proc. of the 3rd Int. Conf. on Simulation Tools and Techniques, ICST*, Mar. 2010, pp. 52-59, doi: 10.4108/ICST.SIMUTOOLS2010.8659.
- [13] M. Imran, A. M. Said, and H. Hasbullah, "A survey of simulators, emulators and testbeds for wireless sensor networks," *2010 International Symposium on Information Technology*, IEEE, Jun. 2010, pp. 897-902, doi: 10.1109/ITSIM.2010.5561571.
- [14] T. Issariyakul and E. Hossain, "Introduction to Network Simulator 2 (NS2)," in *Introduction to Network Simulator NS2*. Springer US, pp. 21-40, 2012, doi: 10.1007/978-0-387-71760-9_2.
- [15] P. Levis, N. Lee, M. Welsh, and D. Culler, "TOSSIM: Accurate and scalable simulation of entire TinyOS applications," *Proc. of the 1st Int. Conf. on Embedded Networked Sensor Systems*, ACM, Nov. 2003, pp. 126-137, doi: 10.1145/958491.958506.
- [16] A. Sobeih et al., "J-Sim: A simulation and emulation environment for wireless sensor networks," *IEEE Wireless Communications*, vol. 13, pp. 104-119, Aug. 2006, doi: 10.1109/MWC.2006.1678171.
- [17] F. Osterlind, A. Dunkels, J. Eriksson, N. Finne, and T. Voigt, "Cross-Level sensor network simulation with COOJA," *Proc. of the 31st Conf. on Local Computer Networks*, IEEE, Nov. 2006, pp. 641-648, doi: 10.1109/LCN.2006.322172.
- [18] E. Perla, A. Ó. Catháin, R. S. Carbajo, M. Huggard, and C. McGoldric, "PowerTOSSIM z: Realistic energy modelling for wireless sensor network environments," *Proc. of the 3rd ACM Workshop on Performance Monitoring and Measurement of Heterogeneous Wireless and Wired Networks*, ACM, Oct. 2008, pp. 35-42, doi: 10.1145/1454630.1454636.
- [19] W. Du, D. Navarro, F. Mieyeville, and I. O'Connor, "IDEA1: A validated system C-based simulator for wireless sensor networks," *Proc. of the 8th Int. Conf. on Mobile Ad-Hoc and Sensor Systems*, IEEE, Oct. 2011, pp. 825-830, doi: 10.1109/MASS.2011.95.