



**HAL**  
open science

## **Presentation and Preliminary Results of DROÏD Project: Development of a Distributed Optical Fibre Dosimeter**

G Beauvois, M. Caussanel, J.-F Lupi, M Ude, S Trzesien, Bernard Dussardier,  
H. Duval, S Grieu

► **To cite this version:**

G Beauvois, M. Caussanel, J.-F Lupi, M Ude, S Trzesien, et al.. Presentation and Preliminary Results of DROÏD Project: Development of a Distributed Optical Fibre Dosimeter. 11th International Symposium on SiO<sub>2</sub>, Advanced Dielectrics and Related Devices, Jun 2016, Nice, France. . hal-02332428

**HAL Id: hal-02332428**

**<https://hal.science/hal-02332428>**

Submitted on 28 Oct 2019

**HAL** is a multi-disciplinary open access archive for the deposit and dissemination of scientific research documents, whether they are published or not. The documents may come from teaching and research institutions in France or abroad, or from public or private research centers.

L'archive ouverte pluridisciplinaire **HAL**, est destinée au dépôt et à la diffusion de documents scientifiques de niveau recherche, publiés ou non, émanant des établissements d'enseignement et de recherche français ou étrangers, des laboratoires publics ou privés.

# PRESENTATION AND PRELIMINARY RESULTS OF DROÏD PROJECT: DEVELOPMENT OF A DISTRIBUTED OPTICAL FIBRE DOSIMETER

G. BEAUVOIS<sup>1</sup>, M. CAUSSANEL<sup>1</sup>, J.-F. LUPI<sup>2</sup>, M. UDE<sup>2</sup>, S. TRZESIEN<sup>2</sup>, B. DUSSARDIER<sup>2</sup>, H. DUVAL<sup>1</sup>, S. GRIEU<sup>1</sup>

<sup>1</sup> [PROMES CNRS, UPR8521, Perpignan, France] <sup>2</sup> [LPMC CNRS, UMR7636 Nice, France]

## 1 Context

Financed by an ANR PIA, Droïd project follows from the Fukushima disaster. It aims to improve security in nuclear power plants (NPP) by developing a distributed dosimeter, with a centimetric resolution, based on the radiation sensitivity of an optical fibre.

## 2 State of the art: dosimeters based on optical fibres

Several radiation sensors based on optical fibres have been developed for the last twenty years. Two types of architecture can be noticed.

1. One fibre can serve as a waveguide to read a unique external radiation sensor [1]. Grouping several fibres permits to get several dose values. However, the number of dose values is limited by the number of fibres that can be joined within one cable.
2. The dosimeter can be built upon a fluorescent or scintillating polystyrene doped plastic fibre. Radiations induce a light emission within the fibre core that is guided by the fibre and then monitored [2]. However this system does not allow to know where, along the fibre, radiation/matter interaction took place.

None of these architectures permits to have a high number of dose measurements (> 100) distributed over a long distance (10-1000 m). There is only one similar system able to measure the dose along a 140 m fibre with 100 measuring points, and a minimal measurable dose of 3 Gy [3]. It uses a phosphorus-doped commercial fibre whose RIA is read by reflectometry. This fibre does not present a dose rate dependence and acts as a good dose integrator with low annealing.

[1] Huston, Nuclear instruments and methods in physics research section B, vol. 187, pp. 55-57, 2001.

[2] Jang, Optical review, vol. 16, no 3, pp. 383-386, 2009.

[3] Henschel, Nuclear instruments and methods in physics research A, vol. 526, pp. 537-550, 2004.

## 3 Project Goals

Within nuclear power plants (NPP), for applications regarding staff radioprotection and environmental dosimetry, the dosimeter specifications, described above, are not suitable. Indeed lower doses must be detected with a better spatial resolution. The first part of this project is to design and manufacture a high radiation sensitive optical fibre.

## 4 Description of samples

- 11 fibres have been fabricated by MCVD. Table below indicates core composition for the 6 most interesting fibres.
- Fibres have a typical length of 1.5 m, winded as unstressed spools.

Name	Composition of oxydes (mol% of oxy.)	Composition of RE/Metal (ppm)
H14	P (0.17 mol% P <sub>2</sub> O <sub>5</sub> ) Al (3.6 mol% Al <sub>2</sub> O <sub>3</sub> )	Er (~ 1900 ppm)
L18	Al (4.6 mol% Al <sub>2</sub> O <sub>3</sub> )	Tm (112 ppm)
I12	P (0.17 mol% P <sub>2</sub> O <sub>5</sub> ) Al (3.6 mol% Al <sub>2</sub> O <sub>3</sub> )	Er (~ 380 ppm)
L22	Al (7.2 mol% Al <sub>2</sub> O <sub>3</sub> )	Tm (210 ± 20 ppm)
L33	Al (2.7 mol% Al <sub>2</sub> O <sub>3</sub> ) Ge (traces)	Ni (traces) Mg (1.1 at%)
Cr20	P (traces) Al (~ 3.6 mol% Al <sub>2</sub> O <sub>3</sub> )	Cr (4 ppm)

## 5 Behaviour of fibres under radiation

- Under radiation, an optical fibre experiences an increase of its attenuation, which is called the Radiation-Induced Attenuation (RIA). Generally, optical fibres present a heterogeneous radiation response.
- Once the irradiation has stopped, RIA can still evolve. If it decreases, the fibre is said "with fading", if it remains constant, the fibre is said "without fading".

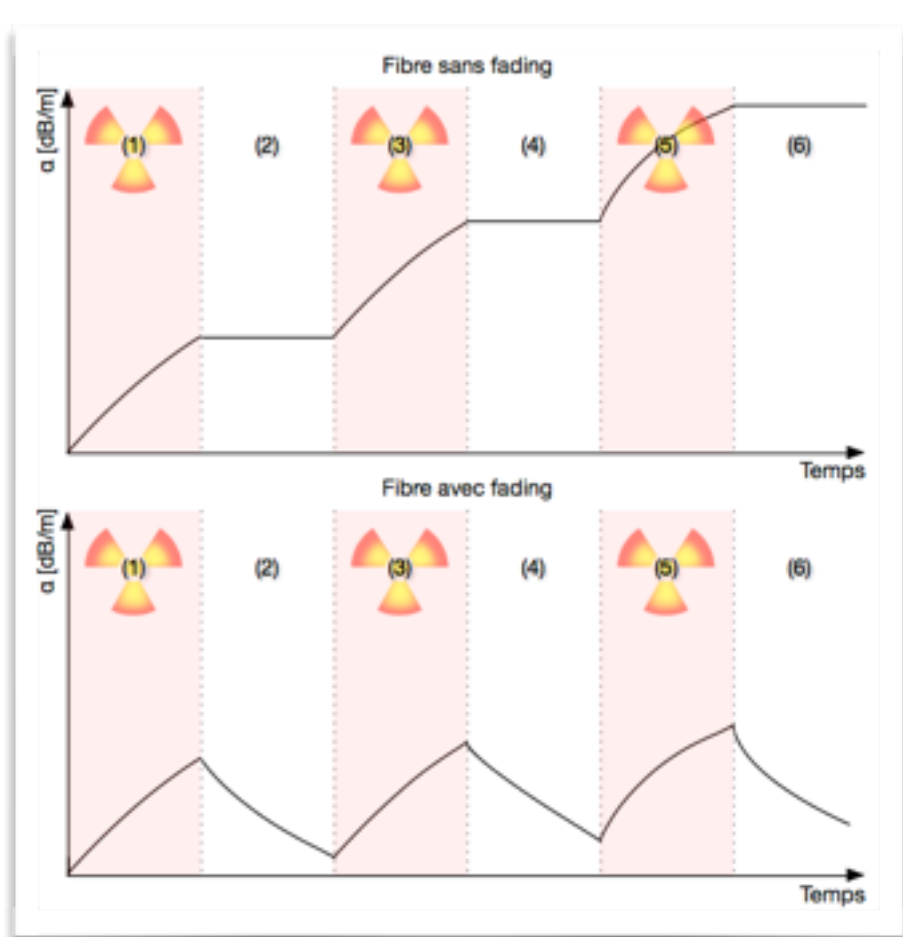

- Fibre without fading: no recovery after an irradiation period.
- 1 level of RIA matches 1 level of dose.
- Fibre with fading: RIA decreases after an irradiation period.
- 1 level of RIA can match several levels of dose.

## 6 Experimental Set-up to measure RIA

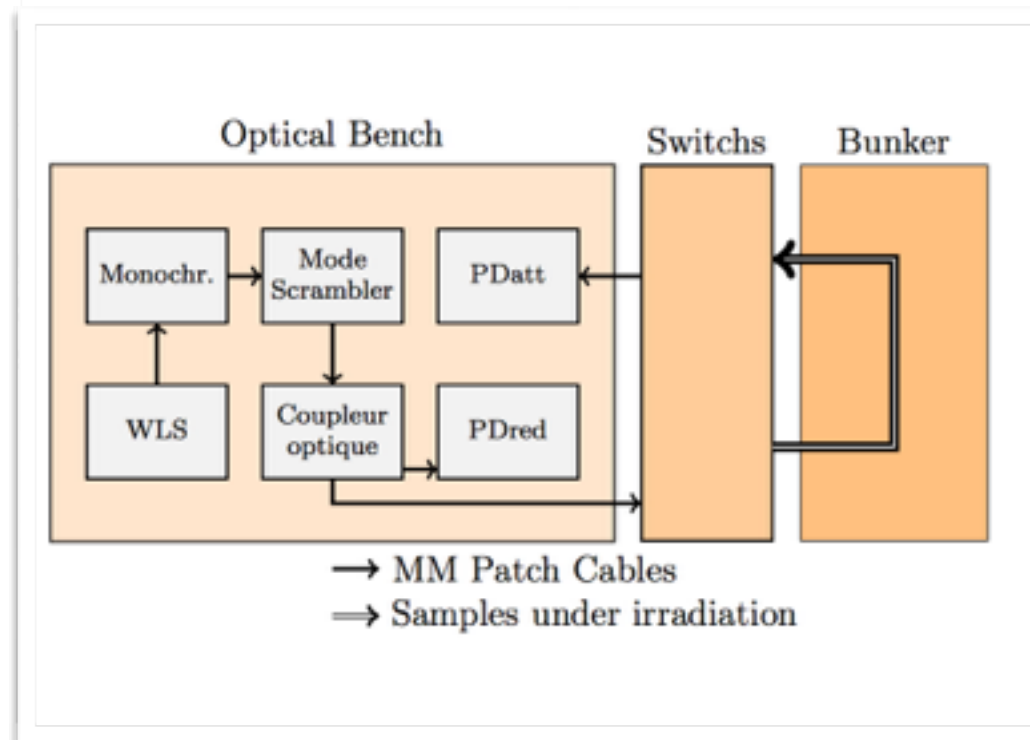

- It permits to measure the RIA within the fibre glass as a function of wavelength (from 400 nm to 1550 nm by 10 nm step).
- Boxes labeled PD### contain each a "two-color" photodiode.
- The fluctuation of WLS and the RIA of patch cables are considered in RIA calculation.
- The optical power injected in the fibre is less than 10 nW, the photobleaching can be neglected.

## 7 Spectra Obtained from Photodiodes PDatt & PDref

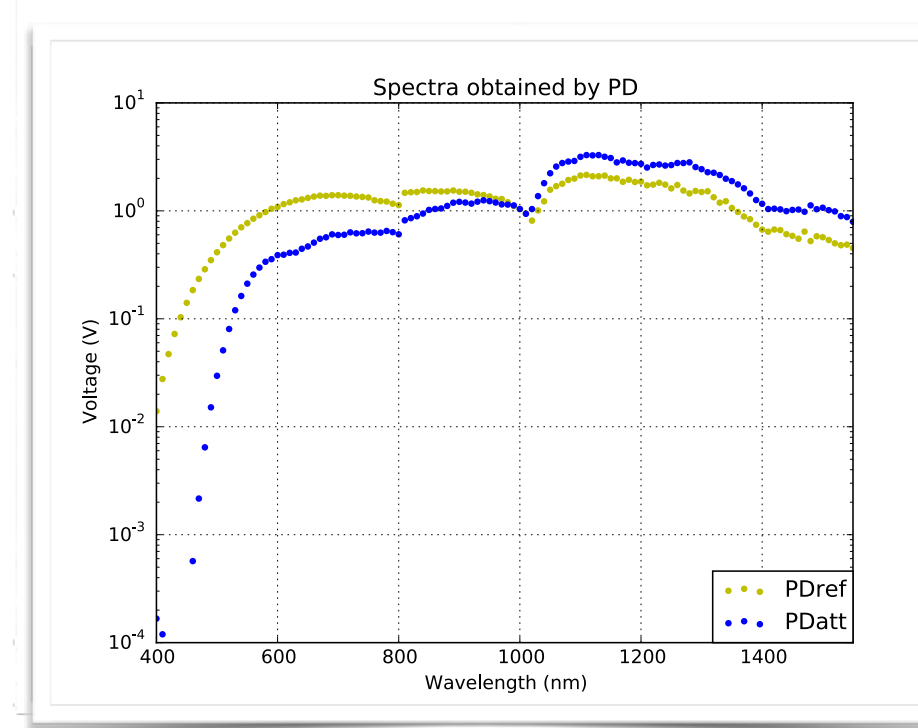

- Voltage ∝ light flux.
- PDref: before the fiber.
- PDatt: after the fiber.
- Radiation-Induced Attenuation:

$$RIA = \frac{(PD_{Att}/PD_{Ref})_{post-irrad}}{(PD_{Att}/PD_{Ref})_{pre-irrad}}$$

## 8 Description of experiments

- RIA have been recorded in situ during 16 hours of irradiation and 6 hours of recovery.
- Dose rate was 10 Gy/h.
- Characterisation have been carried out from 400 to 1550 nm by 10 nm step.

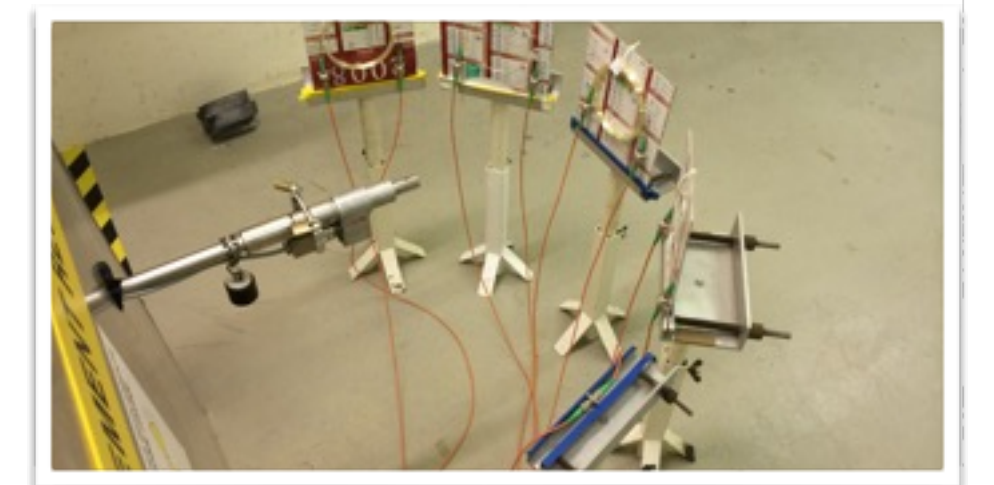

## 9 Results: comparison

- Results presented below focus on the 850 nm wavelength where the highest RIA has been observed among the 3 telecommunication windows.
- The highest RIA are compared to the RIA of commercial fibres studied in the past [4][5] (assuming a linear RIA variation as function of dose).

Our samples	RIA [dB/m] at 850 nm after 1 Gy	Commercial fibre	RIA at 850 nm after 1 Gy
H14	0.12	MM-P4	0.00160
L18	0.10	Draka S. RadHard	0.00060
I12	0.08	Draka MM50	0.00019
L22	0.08	Draka MaxCap300	0.00017
L33	0.06	MM-06	0.00014
Cr20	0.05		

[4] Radfiber database, <http://radfiber.univ-perp.fr>

[5] Ott, NSREC 2002, conference proceedings, pp. 24-31, 2002.

## 10 Normalized recovery (interpolated data)

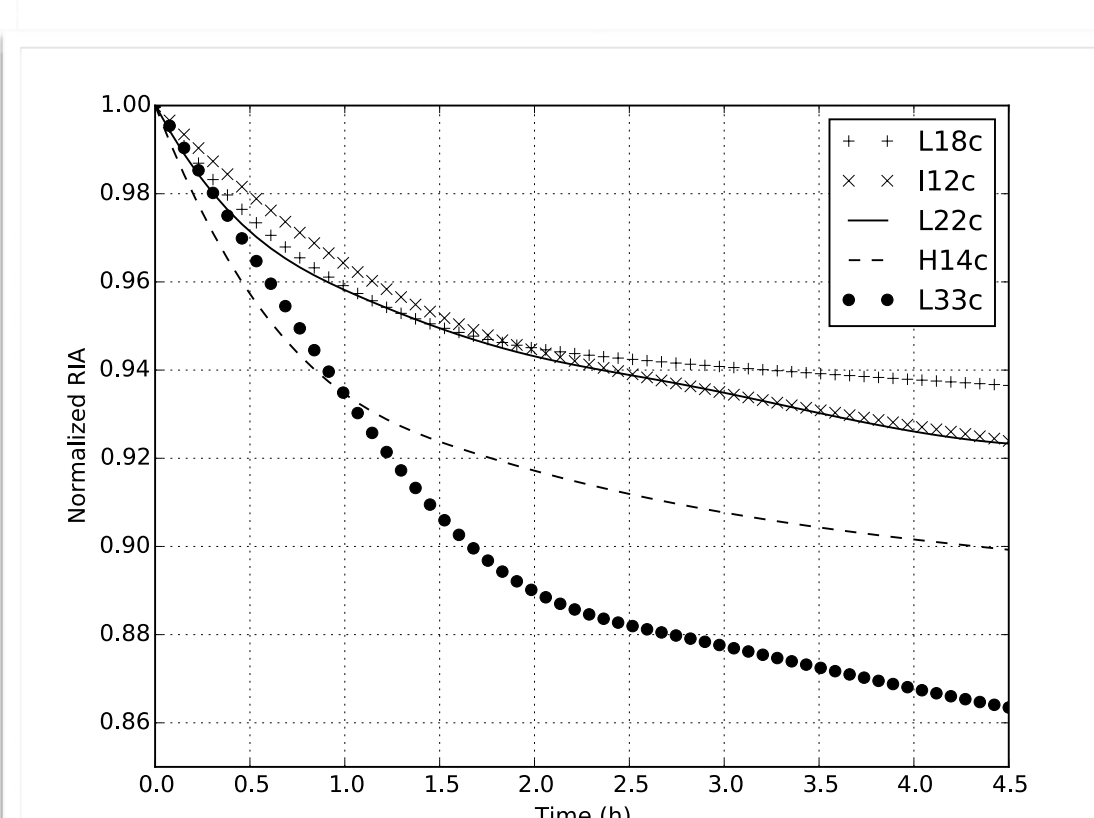

- Past studies have shown that phosphorous could mitigate fibre recovery in the near IR region [6].
- All samples present a significant annealing despite the fact of some are doped with phosphorous.

[6] Brichard, Second European Workshop on Optical Fibre Sensors, vol. 5502, pp. 184-187, 2004.

## Conclusion

- 11 fibres have been irradiated by gamma rays at dose rate 10 Gy/h. RIA have been recorded in situ during 16 h of irradiation and 6 h of recovery.
- Two samples present a very interesting sensitivity, near 100 times the sensitivity of standard fibres. The first two are suitable for dosimetry purposes regarding staff radioprotection.
- Several dopants and their combination have been identified as a good starting point to design a high RIA fibre. 60 new samples have been manufactured and will soon be characterised.