

# **Nonlinear noise measurement of microwave amplifiers**

## **HF noise parameters and residual phase noise**

*O. Llopis, L. Escotte, S. Gribaldo, C. Chambon*

LAAS-CNRS, Toulouse University  
7 av. du Colonel Roche, 31077 Toulouse, FRANCE

e-mail : [llopis@laas.fr](mailto:llopis@laas.fr)

# Outline

## *Tools for theory to experiment comparison in nonlinear noise modelling*

- Introduction : difficulty of nonlinear noise modelling
- Residual phase noise measurement of microwave amplifiers / transistors
- LF noise measurement under large signal operation
- Nonlinear noise figure measurement of microwave amplifiers / transistors
- Correlation between nonlinear HF noise and phase noise floor
- Example of an SiGe HBT phase noise modelling

## Introduction :

⇒ *usefulness and difficulty of noise modelling in nonlinear devices and circuits*

### ***1) Usefulness of nonlinear noise modelling***

- Predicting phase noise in oscillators
- Predicting phase noise in mixers, amplifiers, phase shifters...
- Predicting the noise floor in the vicinity of an amplifier driven by a large signal

### ***2) Difficulty of nonlinear noise modelling***

- Correlation between noise sources at the signal harmonics frequencies
- Modification of the equivalent circuit model at a given harmonic by the large signal at a different harmonic frequency
- Change of the bias point with the large signal
- Nonlinear behaviour of the noise source itself

The intrinsic noise sources are related to the phase fluctuations (or to the extrinsic LF noise) through nonlinear coefficients

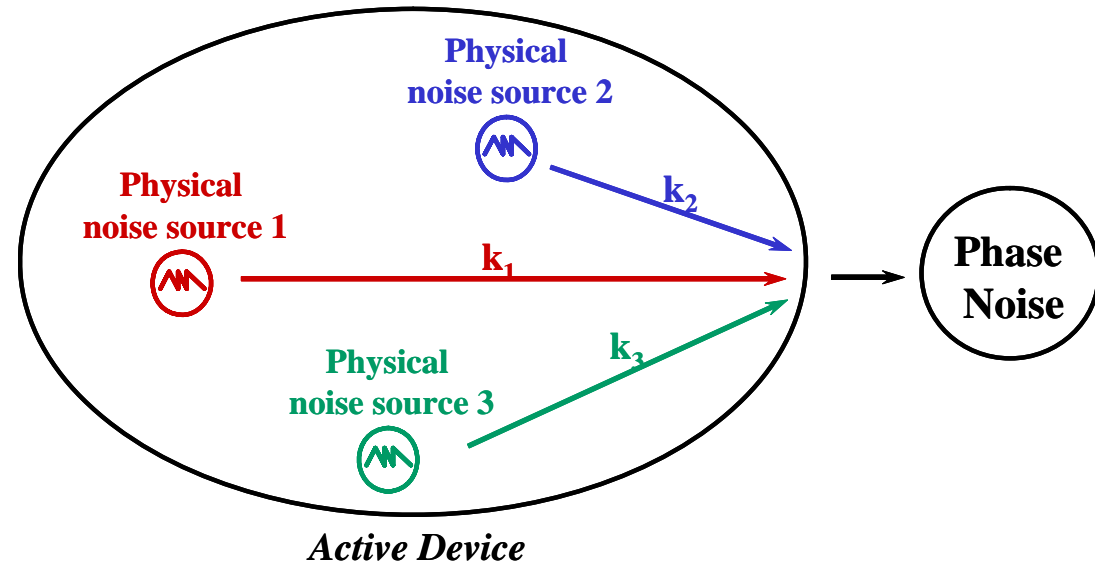

$$S_{\phi} = k_1^2(V_{gs}, V_{ds}) S_1 + k_2^2(V_{gs}, V_{ds}) S_2 + k_3^2(V_{gs}, V_{ds}) S_3$$

The intrinsic noise sources are instantaneously dependent on the RF current  
 -> cyclostationary noise

Ex : G-R noise

$$S_I = \frac{K I^2}{1 + \left(\frac{\omega}{\omega_c}\right)^2} \quad I^2 = I_{DC}^2 \quad \text{or} \quad I = \langle I(t)^2 \rangle \quad ?$$



**Necessity of an efficient measurement tool to evaluate the model accuracy, at different RF pump power levels**

# The simplified feedback oscillator model

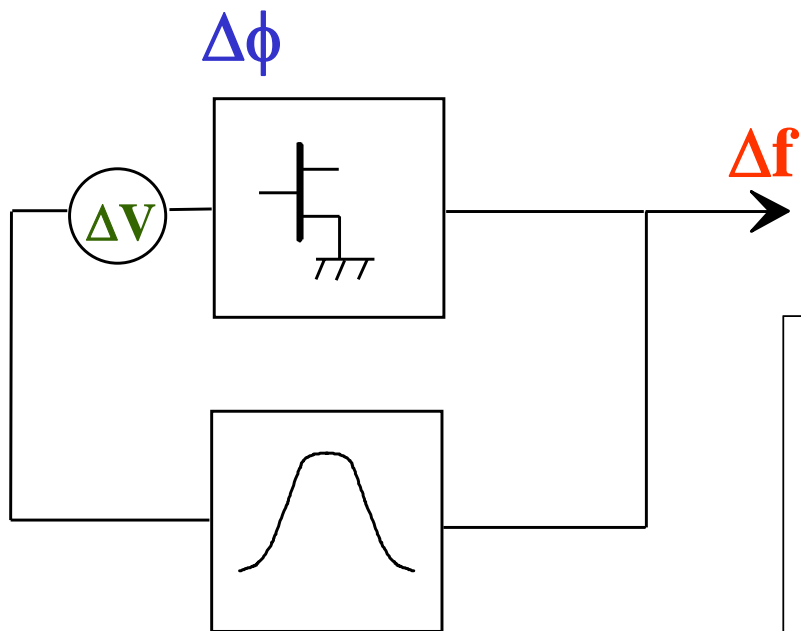

$\Delta f$  = oscillator frequency noise

$\Delta\phi_t$  = transistor (open loop) phase noise

$\Delta V$  = equivalent input noise voltage (LF or HF)

$$\frac{d\phi}{df} = \frac{2Q}{f}$$

$$\Delta f = \frac{\Delta\phi_t}{\frac{d\phi}{df}} = \frac{f_0}{2Q} \Delta\phi_t$$

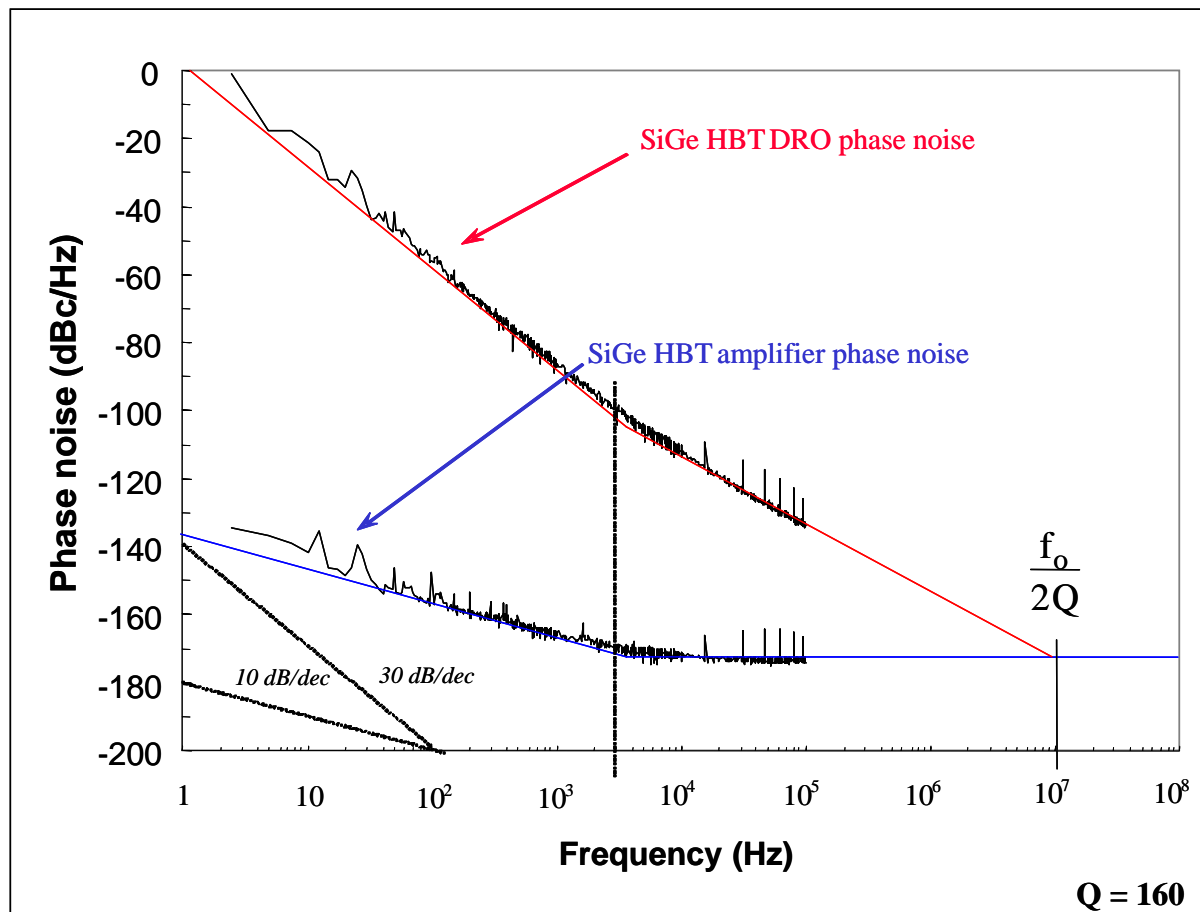

Example of phase to frequency conversion in a 4 GHz SiGe HBT oscillator

# Residual phase noise measurement of low phase noise amplifiers and transistors

## Advantages of open loop (or residual) phase noise studies versus oscillator phase noise studies :

### **SIMULATION**

- ⇒ Faster for a driven circuit than an autonomous circuit
- ⇒ Possibility to analyse the noise conversion both in linear and nonlinear modes

### **MEASUREMENT**

- ⇒ Better control of the parameters (no needs for a loop phase control)
- ⇒ Measurement from linear to nonlinear mode, with a precise set of input power levels

## Amplifier phase noise characterisation

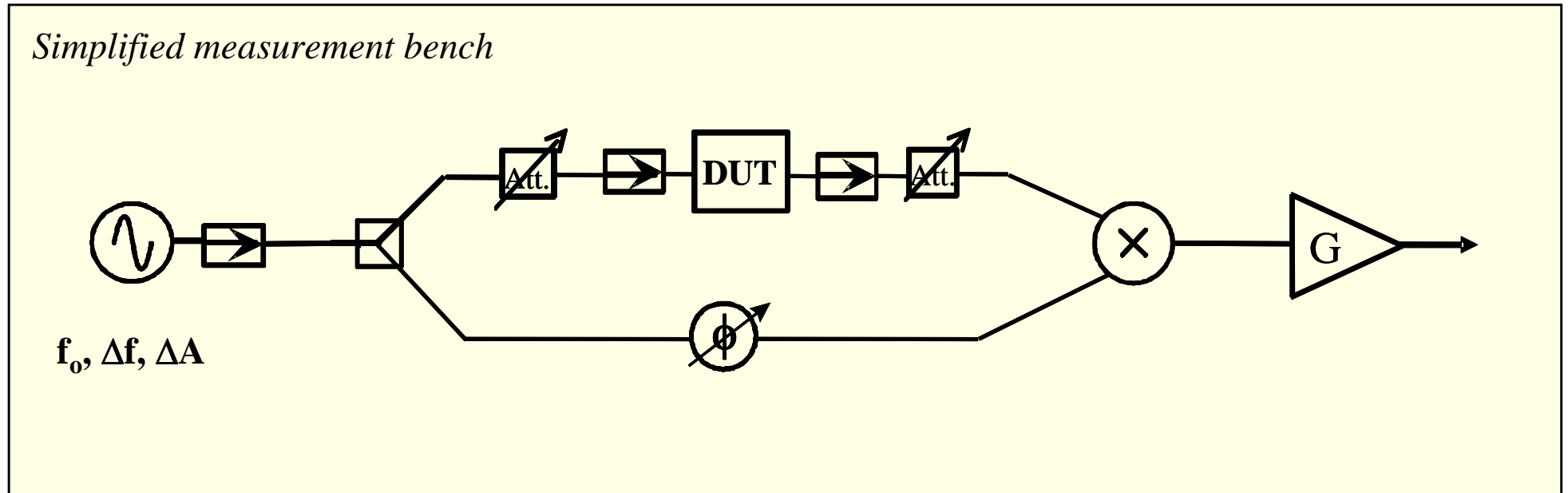

$$\Delta \bar{V}_s^2 = \underbrace{G^2 K_\phi^2 \Delta \bar{\varphi}_t^2}_{\text{DUT noise}} + \underbrace{(2\pi\tau)^2 G^2 K_\phi^2 \Delta \bar{f}^2 + G^2 K_{AM}^2 \Delta \bar{A}^2 + G^2 K_\phi^2 \Delta \bar{\varphi}_{\text{mel}}^2 + G^2 \Delta \bar{V}_{\text{ampli}}^2}_{\text{Noise Floor}}$$

# Amplifier phase noise characterisation

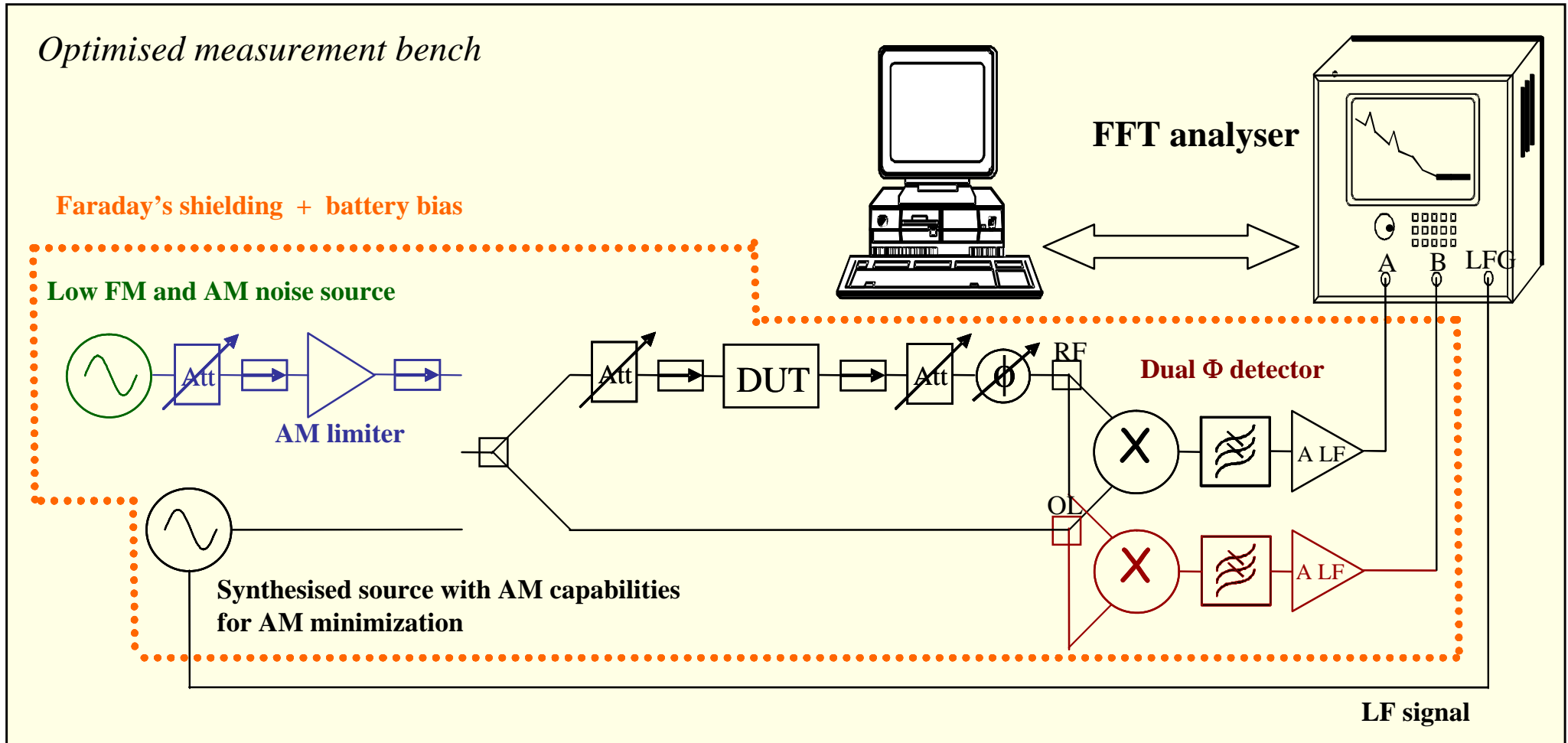

$$\Delta \bar{V}_s^2 = \underbrace{G^2 K_\phi^2 \Delta \bar{\phi}_t^2}_{\text{DUT noise}} + \underbrace{(2\pi t)^2 G^2 K_\phi^2 \Delta \bar{f}^2 + G^2 K_{AM}^2 \Delta \bar{A}^2 + G^2 K_\phi^2 \Delta \bar{\phi}_{mel}^2 + G^2 \Delta \bar{V}_{ampli}^2}_{\text{Noise Floor}}$$

*Delay balance and low phase noise source*     
 *AM limiter and low AM noise source*     
 *Low 1/f noise Si detector / amplifier + cross-correlation detection*



# Amplifier phase noise characterisation : *measurement capabilities and AM rejection problem*

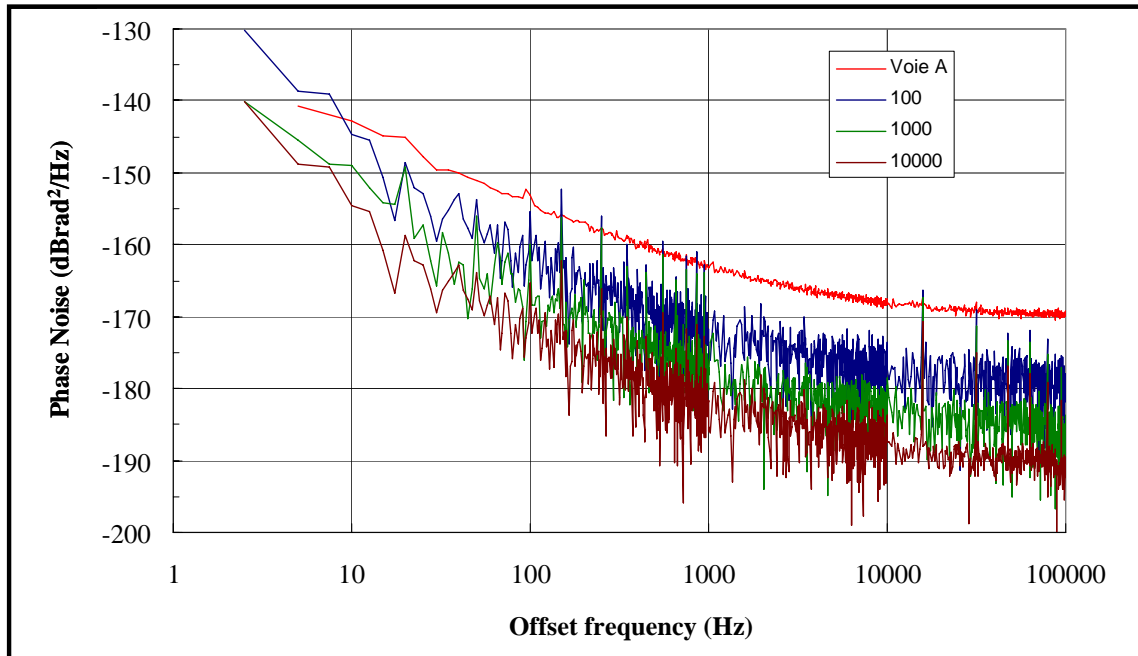

*Advantage of the dual detector / cross-spectrum technique :  
effect of the averaging number on the 3.5 GHz noise floor*

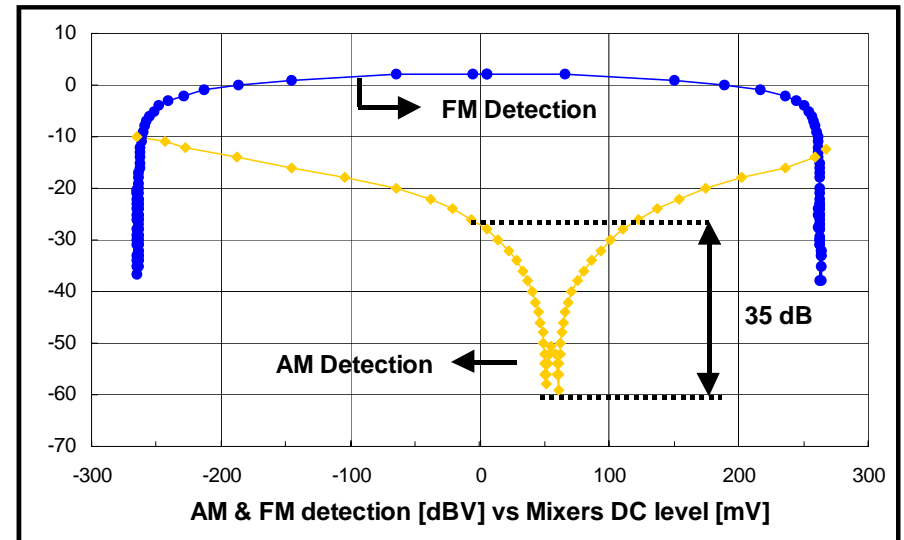

*Phase (or frequency) detection, at the mixer level  
versus mixer DC output*

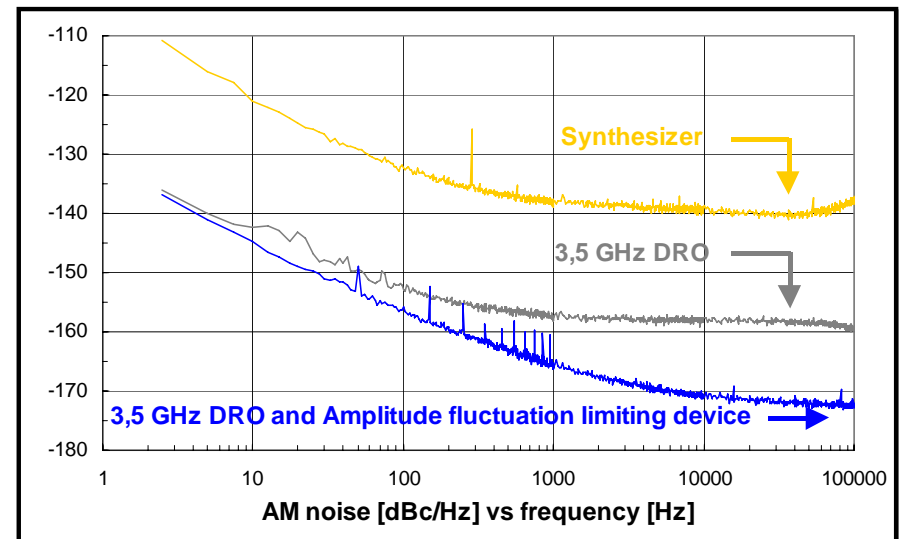

*AM noise of different microwave sources*

# LF noise measurement under large signal operation

- ➡ Complementary measurement to phase noise, to investigate experimentally the correlation between LF noise and phase noise

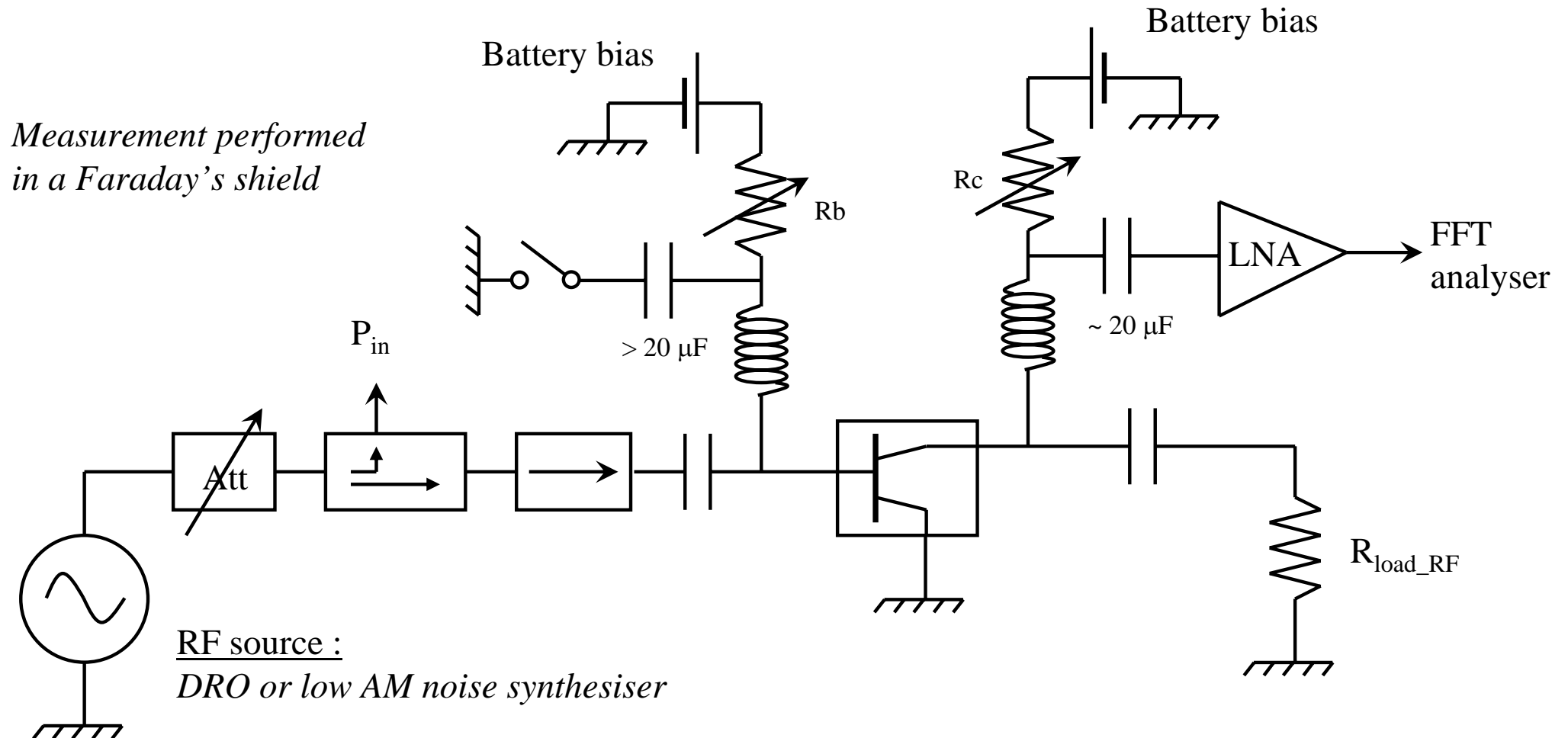

## Measurement example 1 : case of a PHEMT device

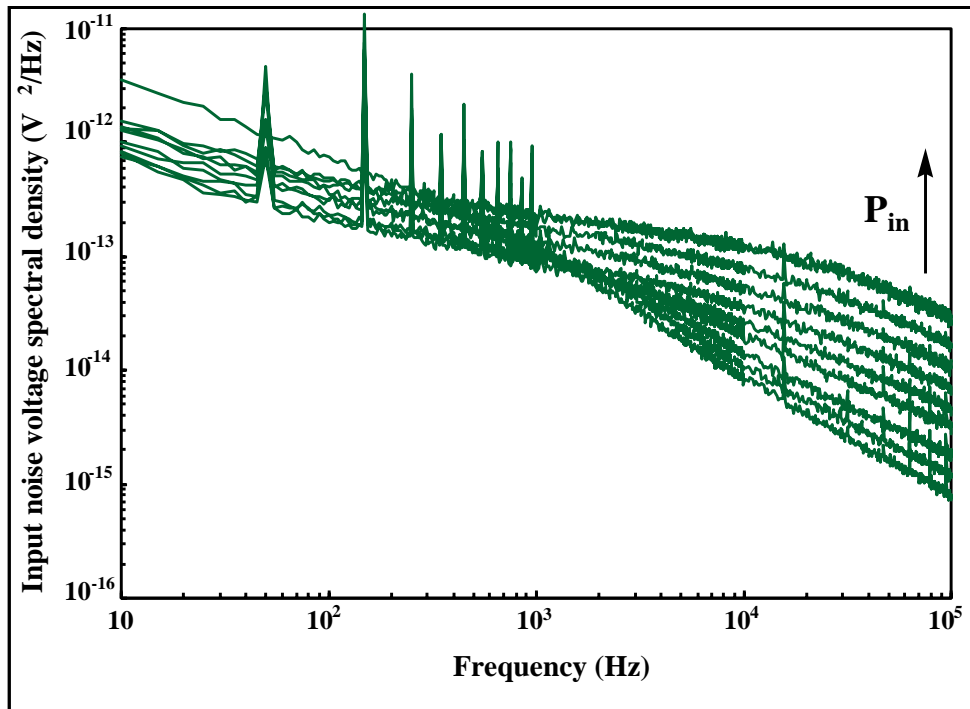

Equivalent gate voltage LF noise spectral density versus  $P_{in}$  (from the linear regime and up to 4 dB compression)

← Measured LF drain current noise divided by the measured LF transimpedance

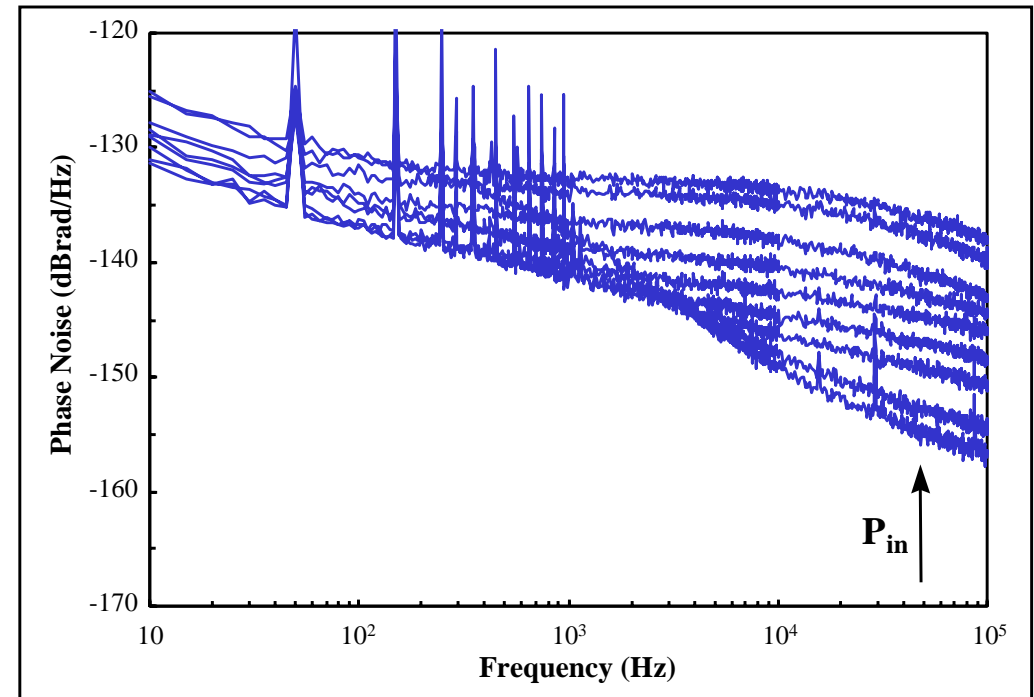

Residual phase noise (dBrad/Hz) versus  $P_{in}$



Llopis et al., IEEE-IMS 2001

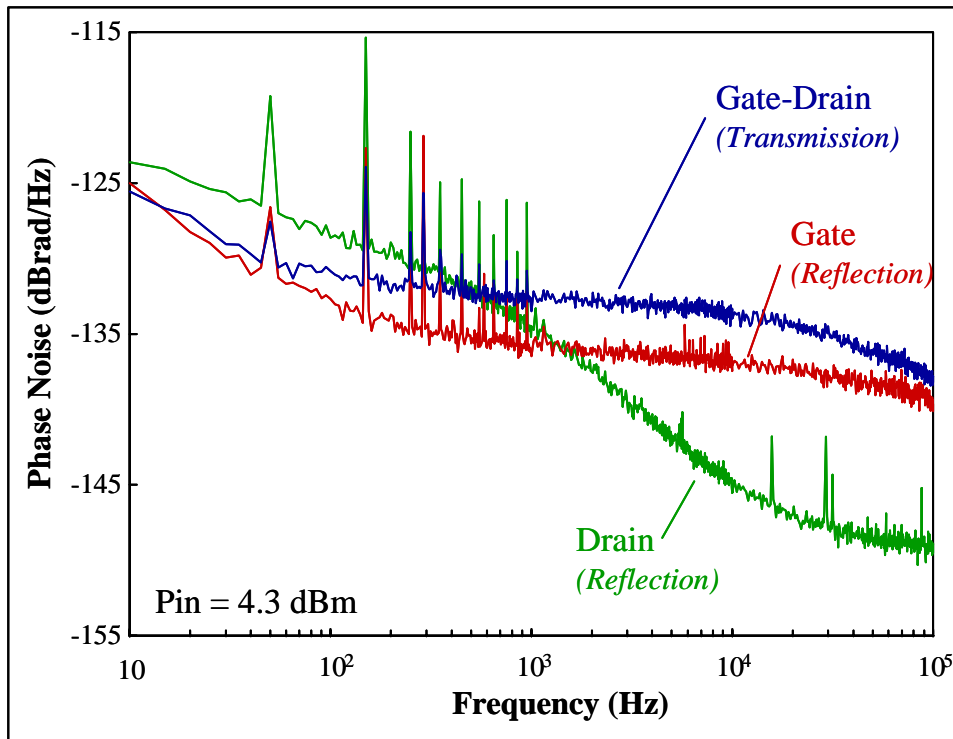

## Transmission and reflection phase noise measurement (for phase fluctuations location)

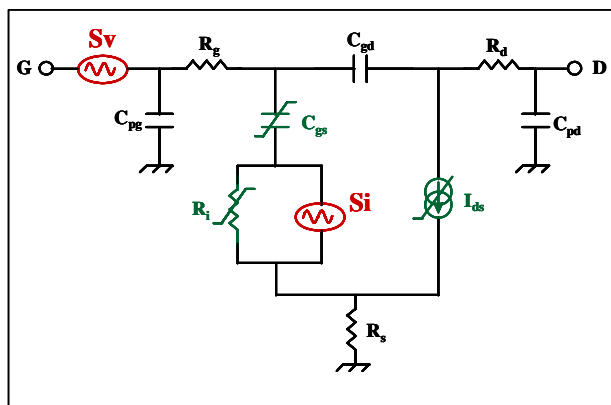
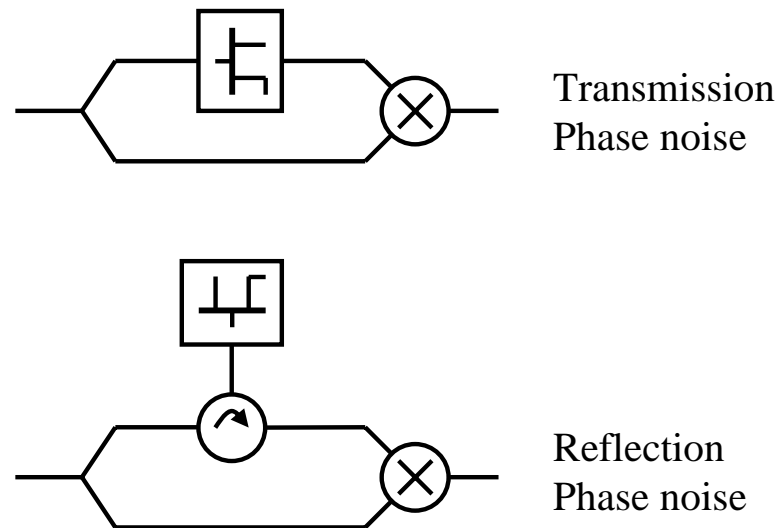

Model proposed (2001 IEEE IMS)

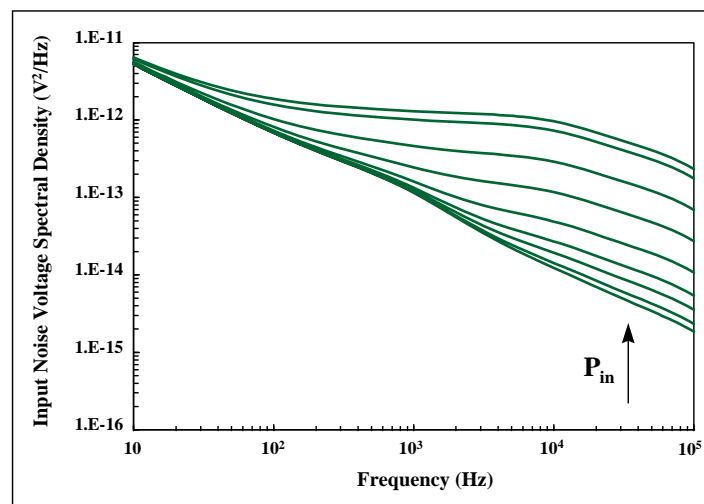

Computed extrinsic gate noise

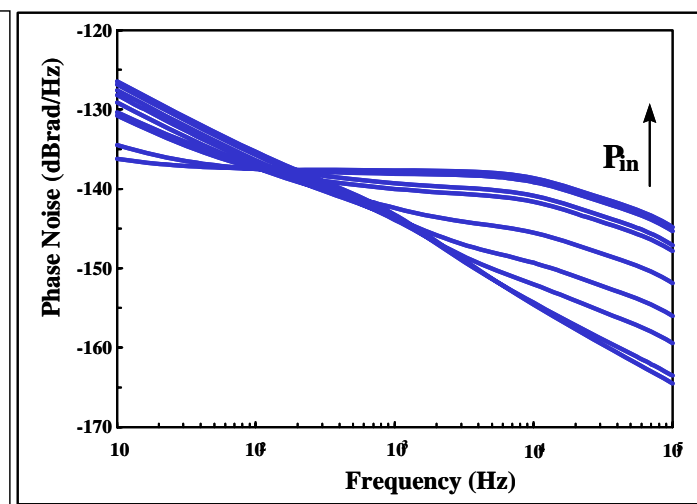

Computed phase noise

## Measurement example 2 : case of SiGe HBTs

*investigations on the effect of the base bias network on the phase noise of a SiGe HBT*

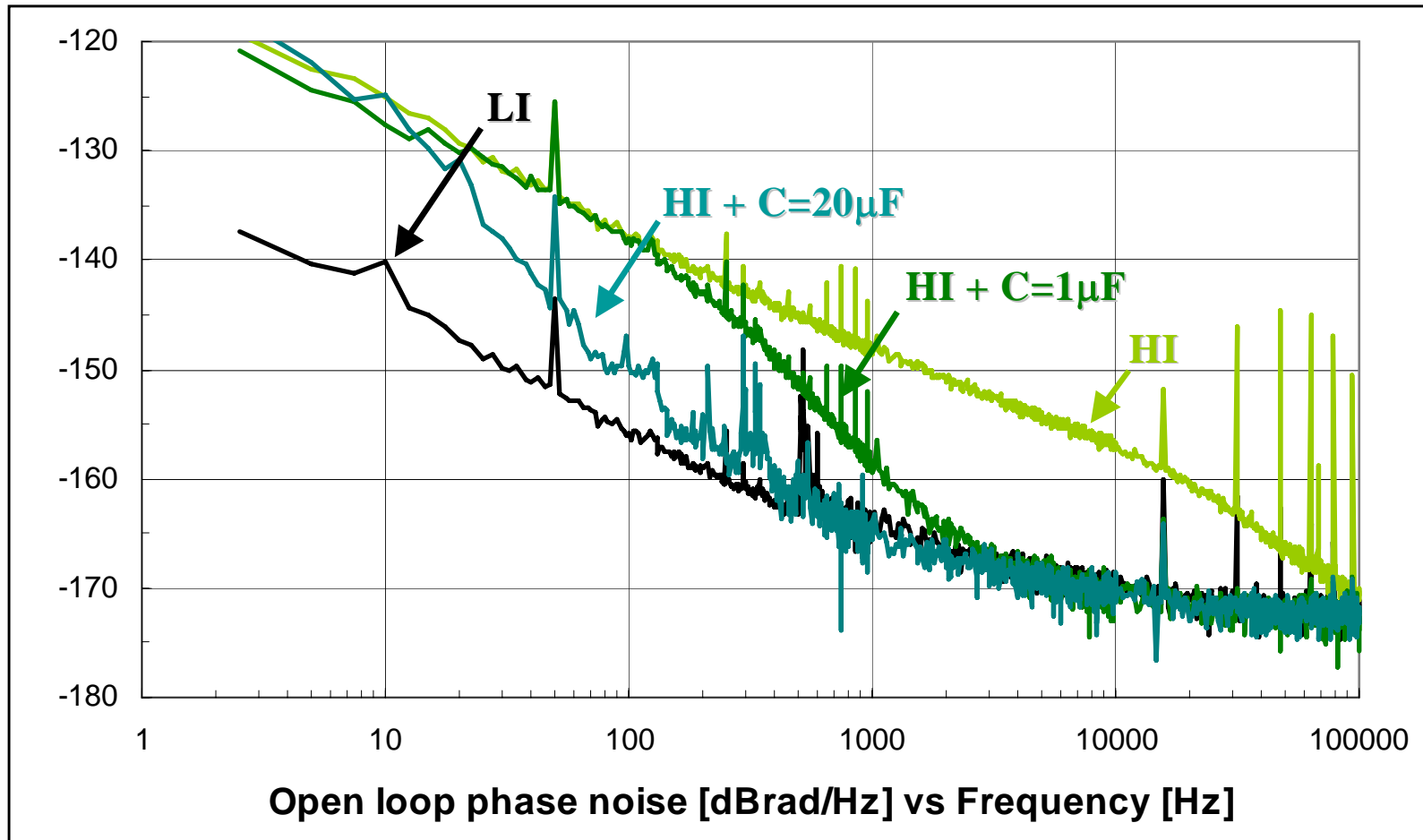

### Residual phase noise of an SiGe HBT amplifier at 3.5 GHz (LPNT 32)

Three types of base bias networks are compared : high impedance bridge, capacitive filtering and low impedance

**The low impedance bias cancels the effect of the  $S_{i_{be}}$  low frequency noise source**

## Measurement example 2 : case of SiGe HBTs

*Investigations on the phase noise of SiGe HBTs versus the microwave input power*

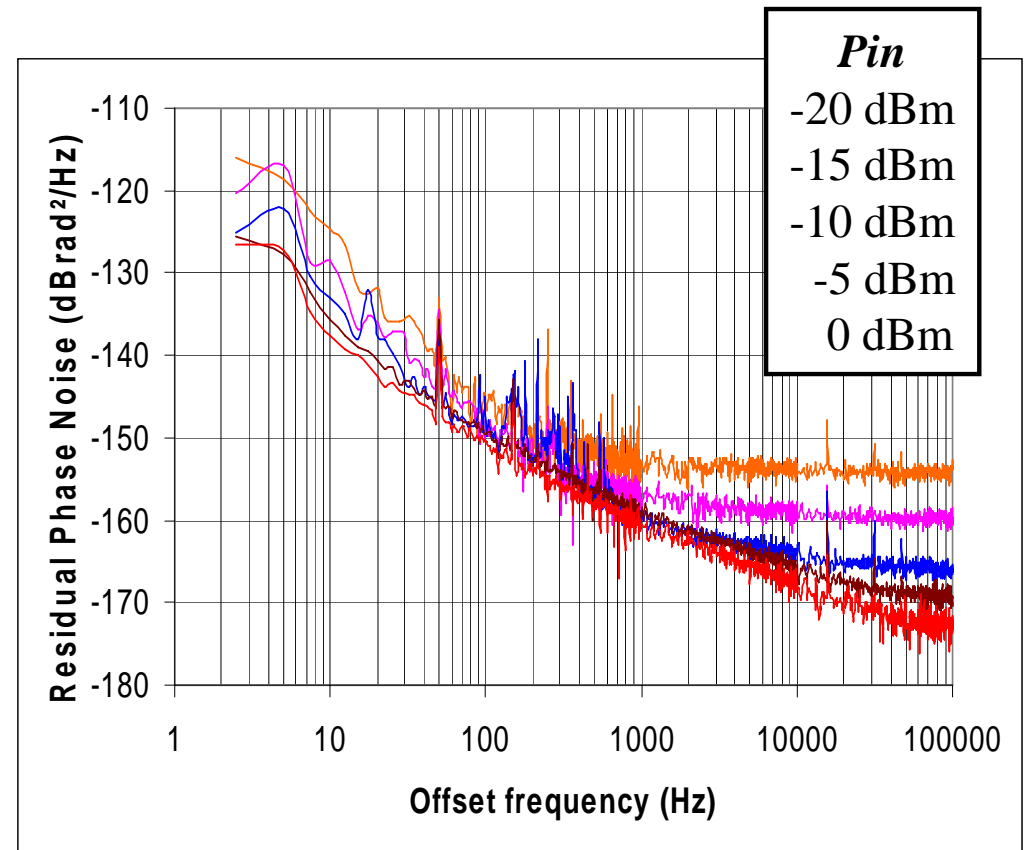
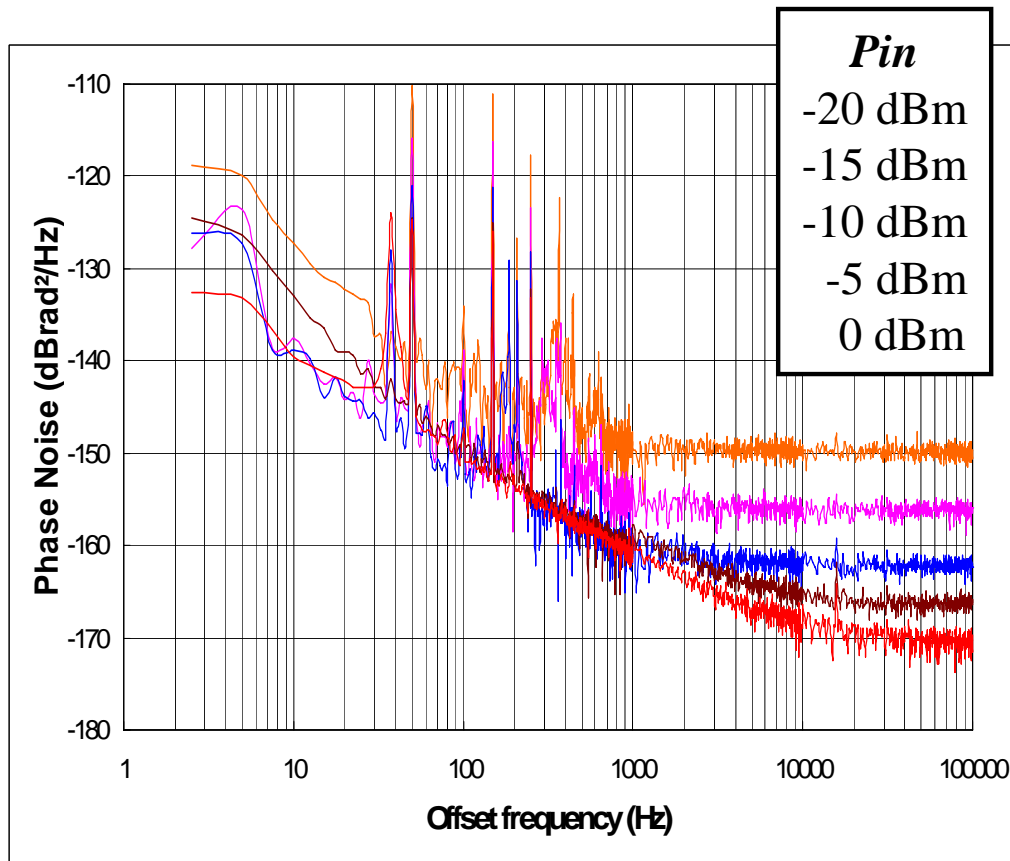

*Case of an SiGe HBT (LPNT32)  
loaded onto 50  $\Omega$  at 3.5 GHz  
from linear regime up to 1dB compression*

*Case of an SiGe HBT (BFP620)  
loaded onto 50  $\Omega$  at 3.5 GHz  
from linear regime up to 1dB compression*

# Phase noise in microwave SiGe HBTs : discussion on the results versus $P_{in}$

*1/f phase noise is necessarily a conversion noise, and is related to the device LF noise*

*White phase noise can result either from a conversion process or be an additive noise*

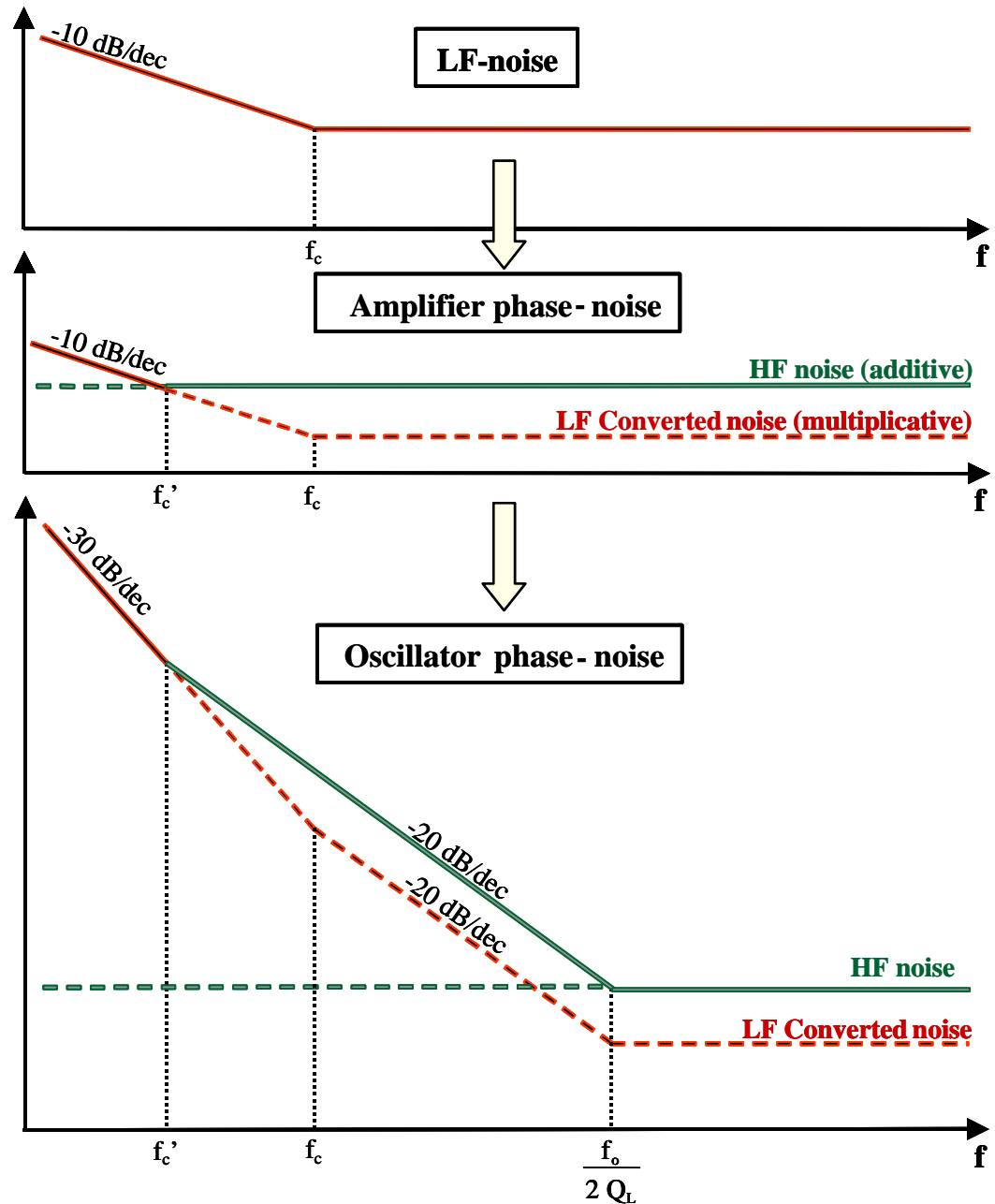
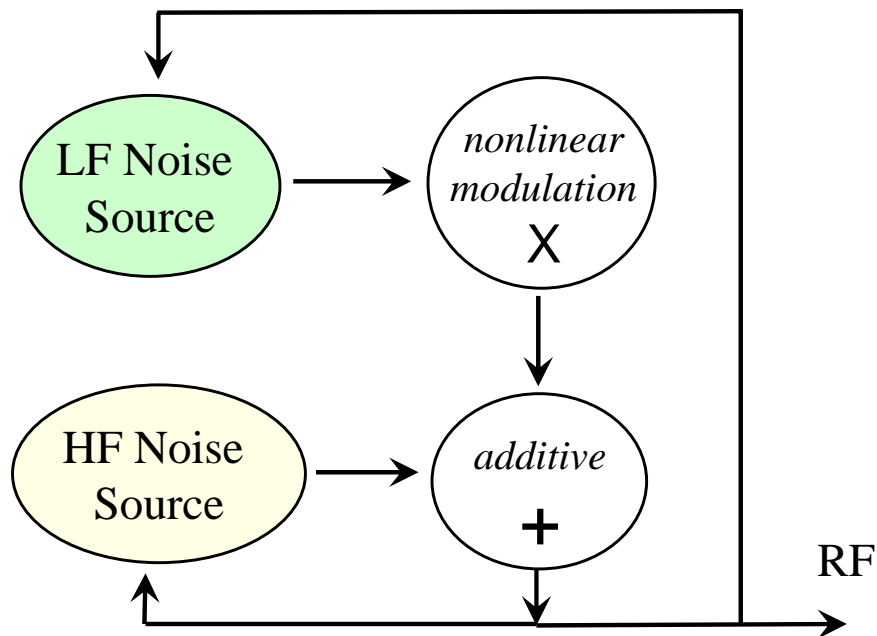

# Phase noise in microwave SiGe HBTs :

*phase noise floor analysis -> HF noise contribution to the phase noise*

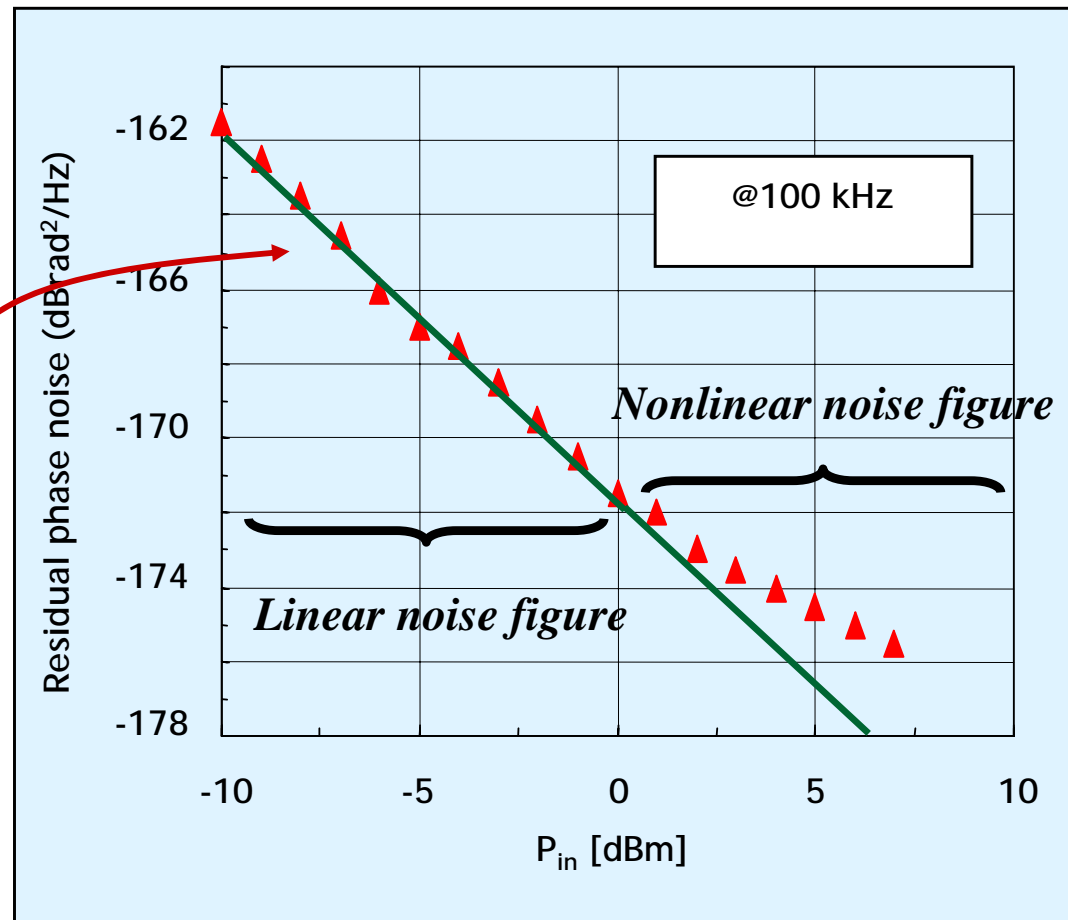
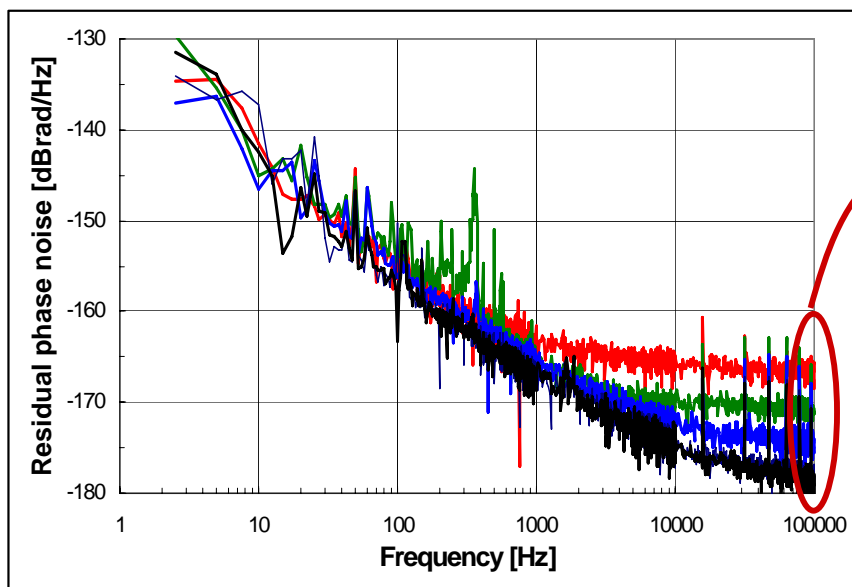

*Signature of an additive phase noise*

$$S_{\Phi_{add}} = \frac{F_{dut} k T_0}{P_{in}}$$

*1 dB/dB slope, at least when the device is not too much driven into compression*

*Cibiel et al., IEEE Trans. on MTT, jan. 2004*



**Question :** *is there a different way to evaluate the far from carrier phase noise floor and to optimise its level versus the device RF load ?*

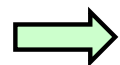

yes, investigations on this noise contribution can be performed using a (modified) noise parameter measurement set-up

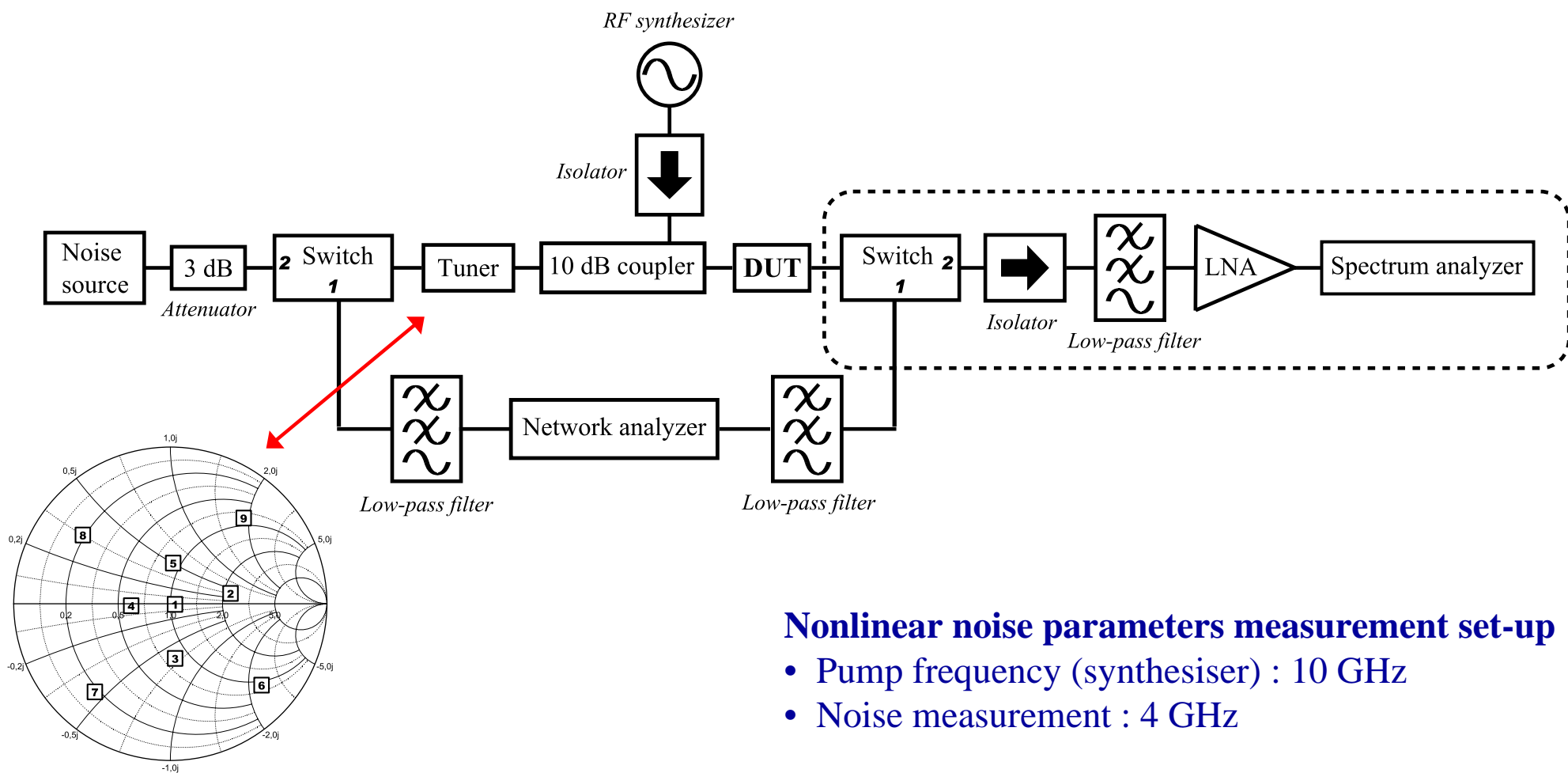

### Nonlinear noise parameters measurement set-up

- Pump frequency (synthesiser) : 10 GHz
- Noise measurement : 4 GHz

# Noise parameters of two microwave amplifiers

- low noise 2 – 22 GHz amplifier (Miteq)
- △- low phase noise 2 – 6 GHz amplifier (AML)

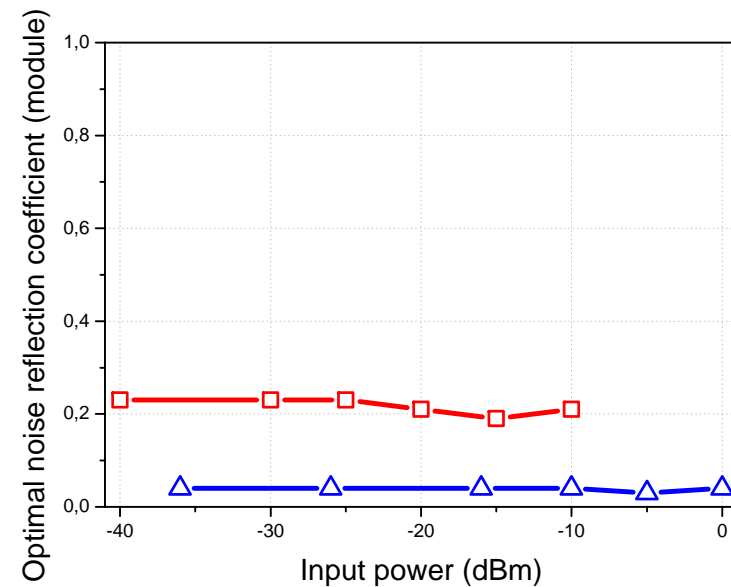
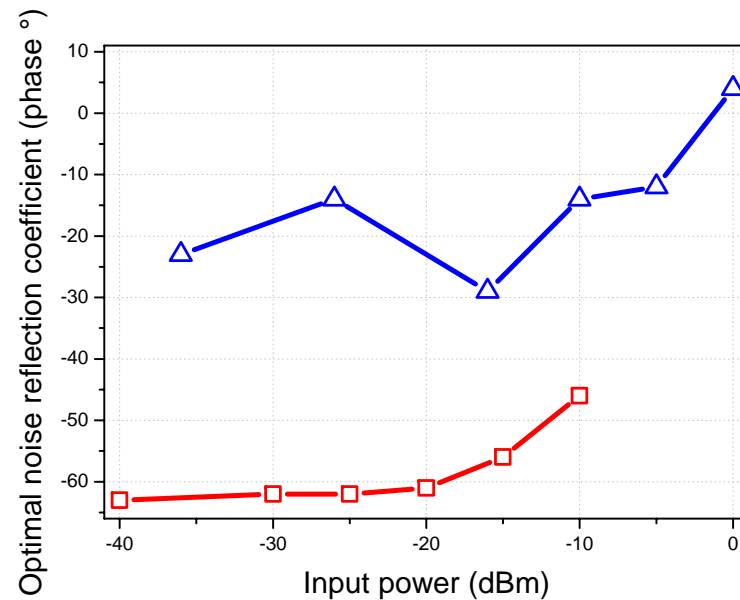
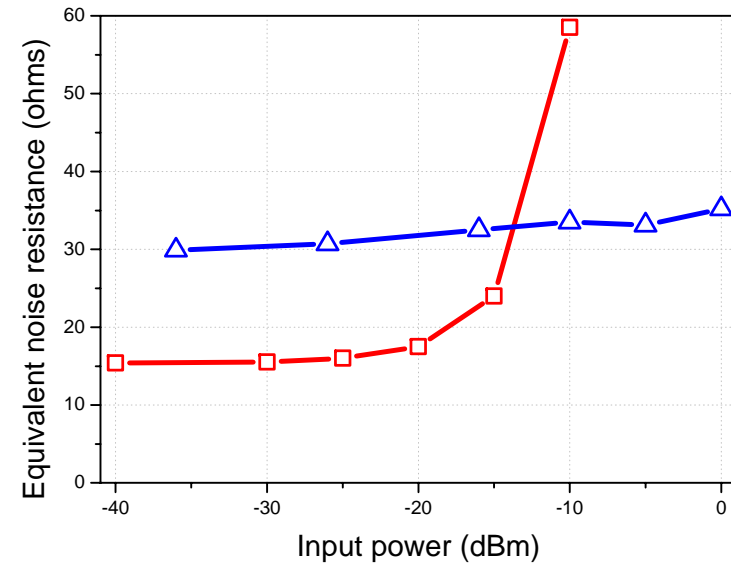
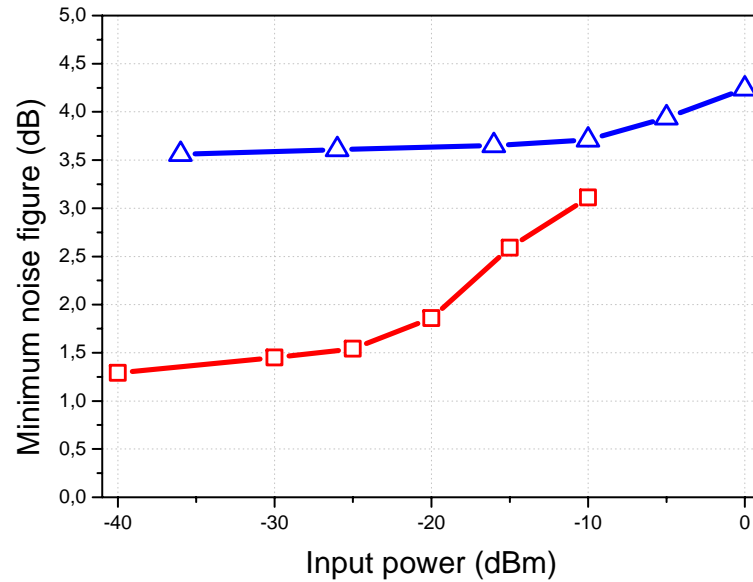

## Correlation of noise figure data with residual phase noise floor data at 4 GHz

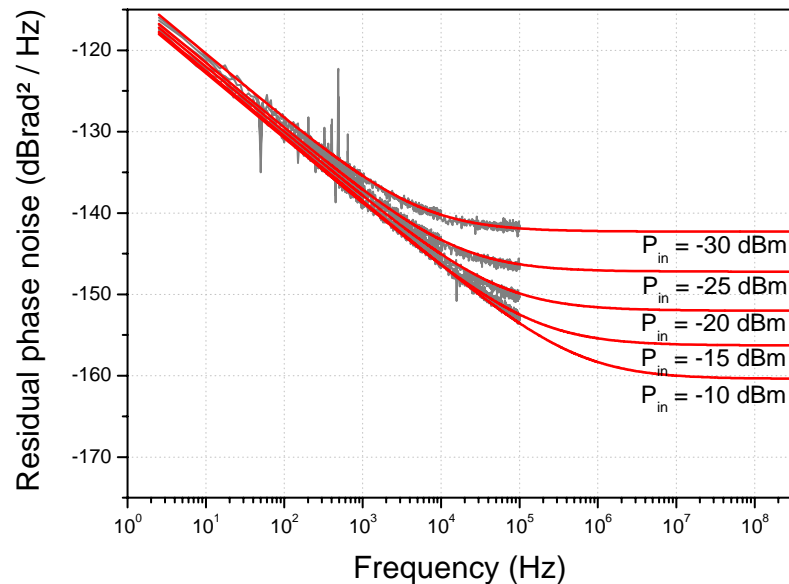
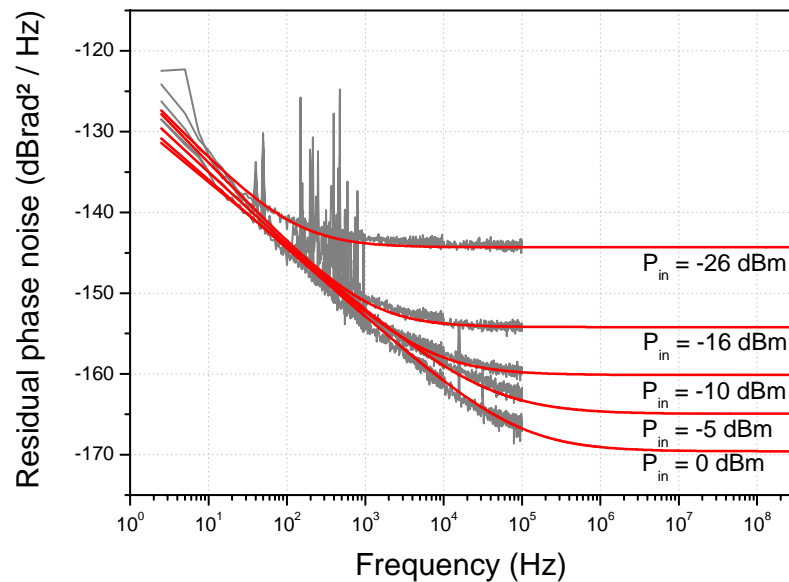

*Due to the phase noise bench frequency offset limitation (100 kHz, due to the FFT analyser), the phase noise floor has been extracted using a fit with a simple model (1/f contribution + noise floor)*

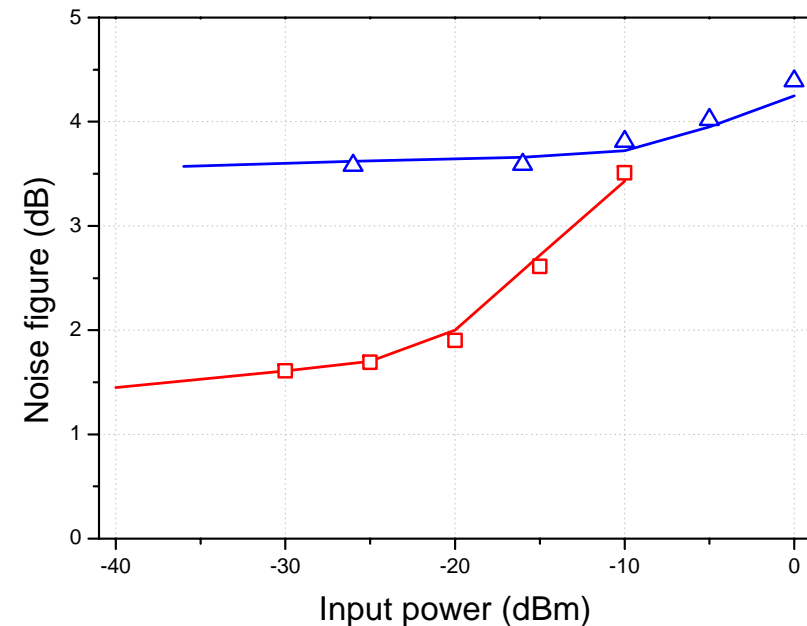

Noise figure extraction based on noise parameters measurement (lines) and on 50  $\Omega$  residual phase noise measurement

## Case of a microwave transistor : SiGe HBT BFY 420 (Infineon)

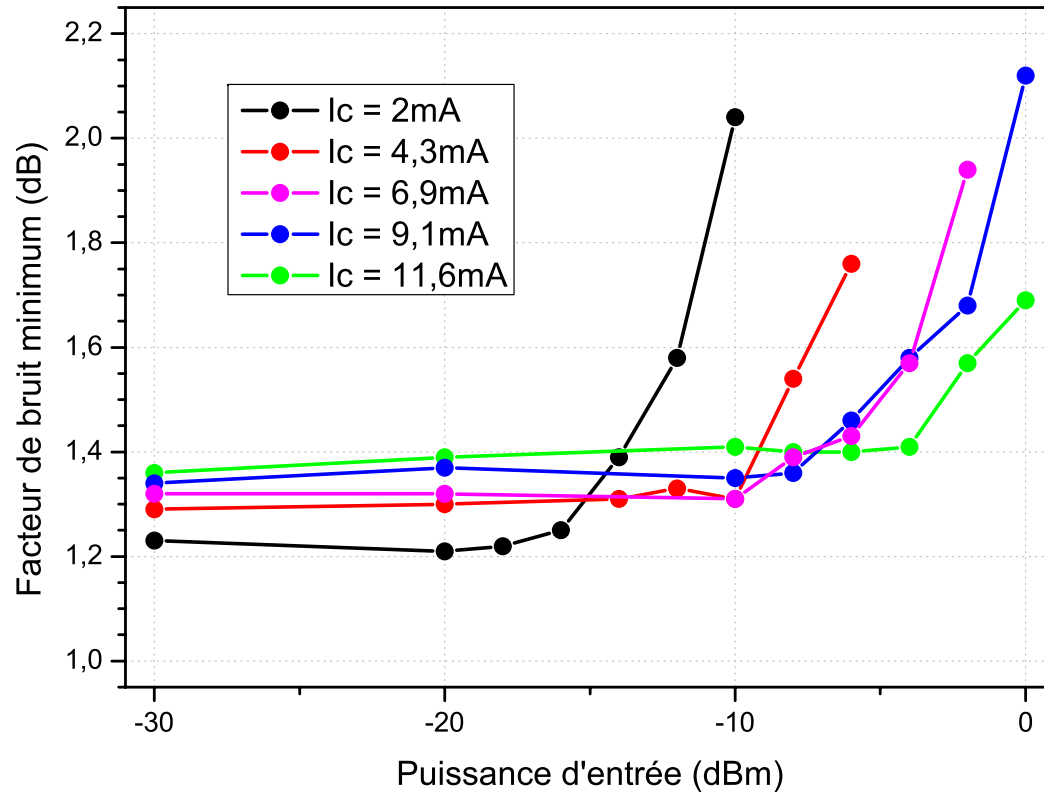

*Characterisation up to 3 dB compression at different bias current*

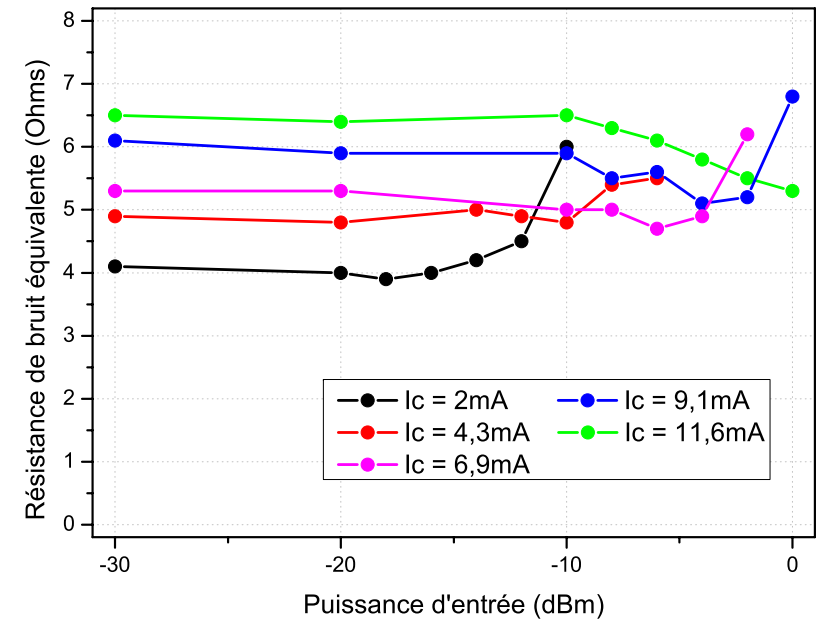

Minimum noise figure ↗

Equivalent noise resistance →

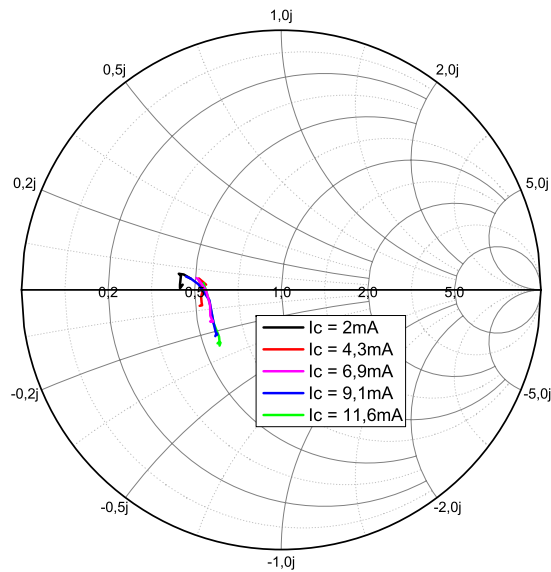
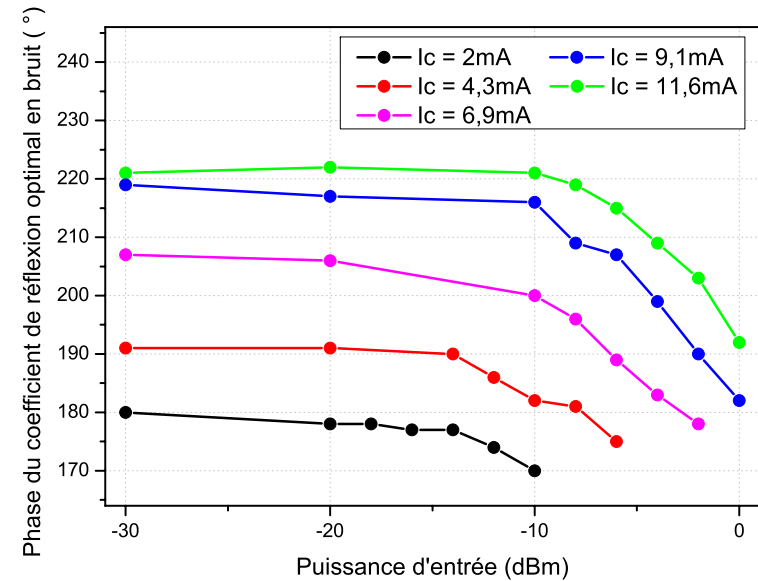
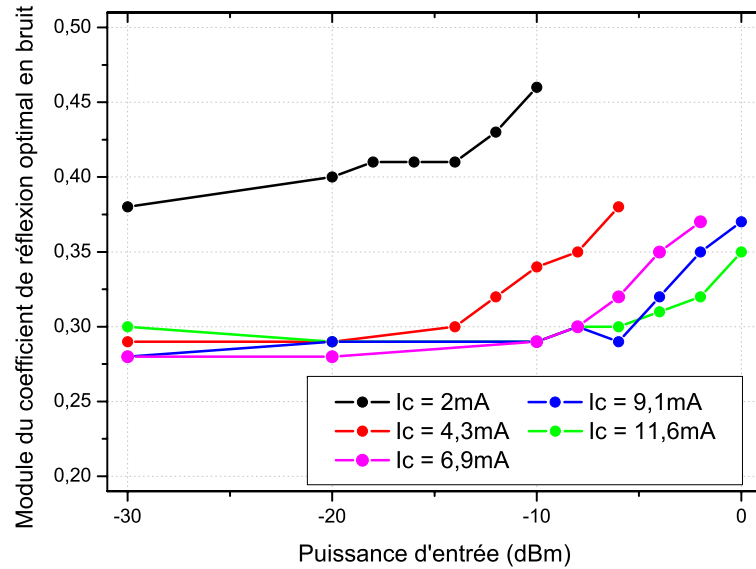

## Optimum noise reflection coefficient

The change of this parameter with power, on this transistor, is not too strong.

However, there is probably a trade-off to find between the optimum load for HF noise and the optimum load for 1/f noise conversion (case of a phase noise application)

BFY 420 SiGe HBT

# Use of residual phase noise data to model the 1/f noise contribution to phase noise

## Case of an SiGe HBT – BFP 620 (Infineon)

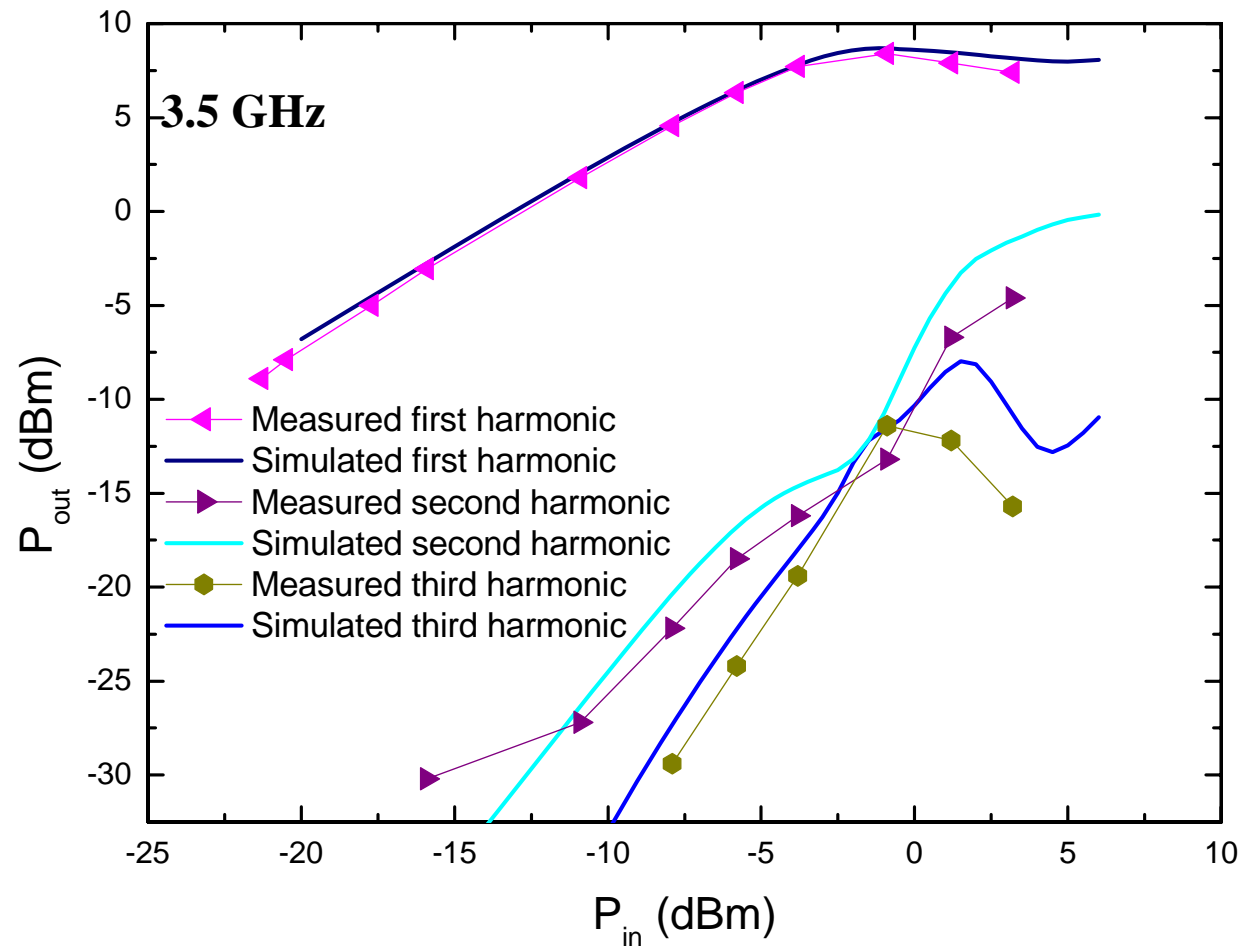

*Rem : this transistor model will be presented at the 2007 ICNF, Tokyo S. Gribaldo et al.*

1<sup>st</sup> step : extraction of an accurate nonlinear model of the device

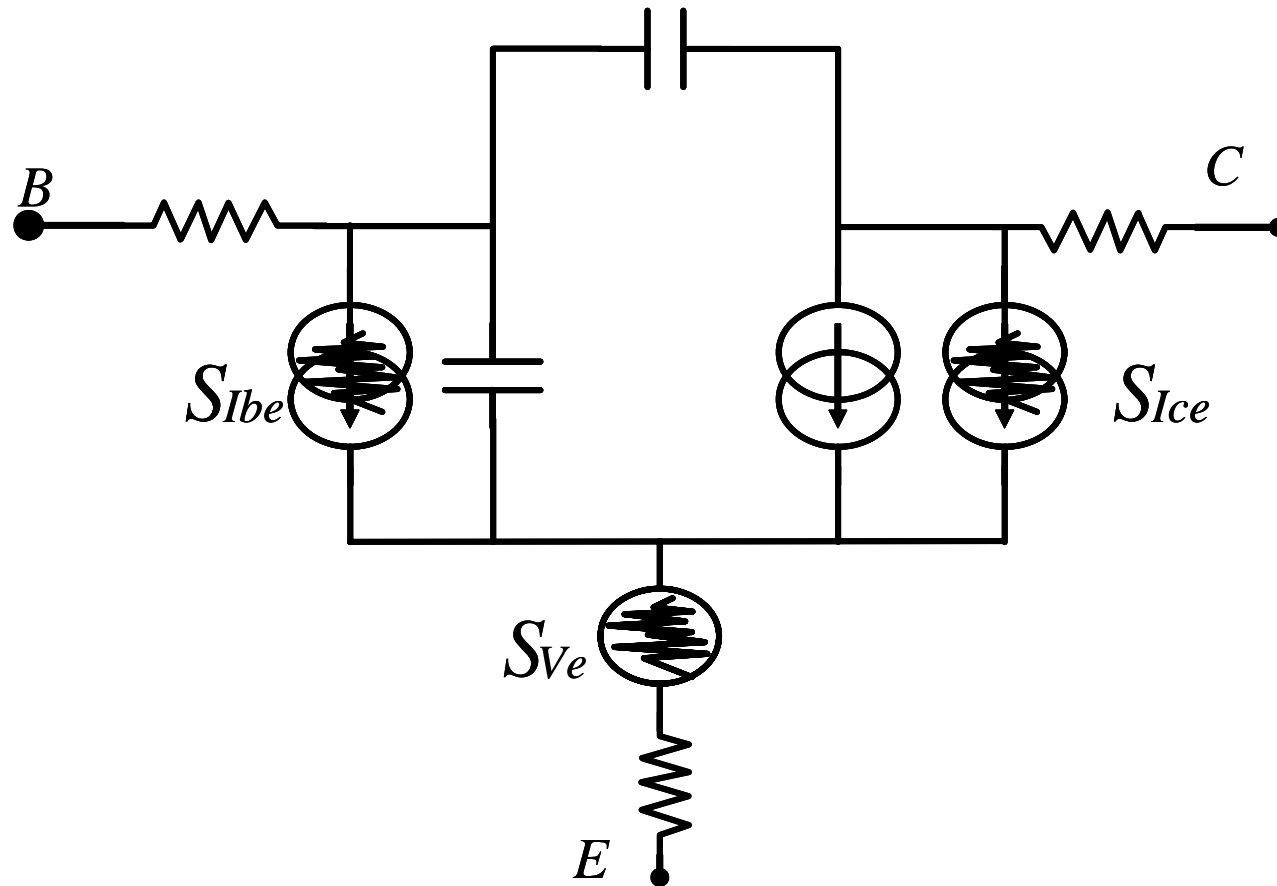

2<sup>nd</sup> step : choice of an LF noise model (intrinsic transistor), not too complex in order to be able to include, as a third step, the nonlinear behaviour

# LF noise extrinsic noise sources measurement at different RF power levels

*BFP620 loaded onto 50 Ω @ 3.5 GHz, from linear condition to 1dB compression*

→ evidence of the independence versus the RF power of the base current noise source

→ evidence of a strong nonlinear behaviour of the equivalent base-emitter voltage noise source

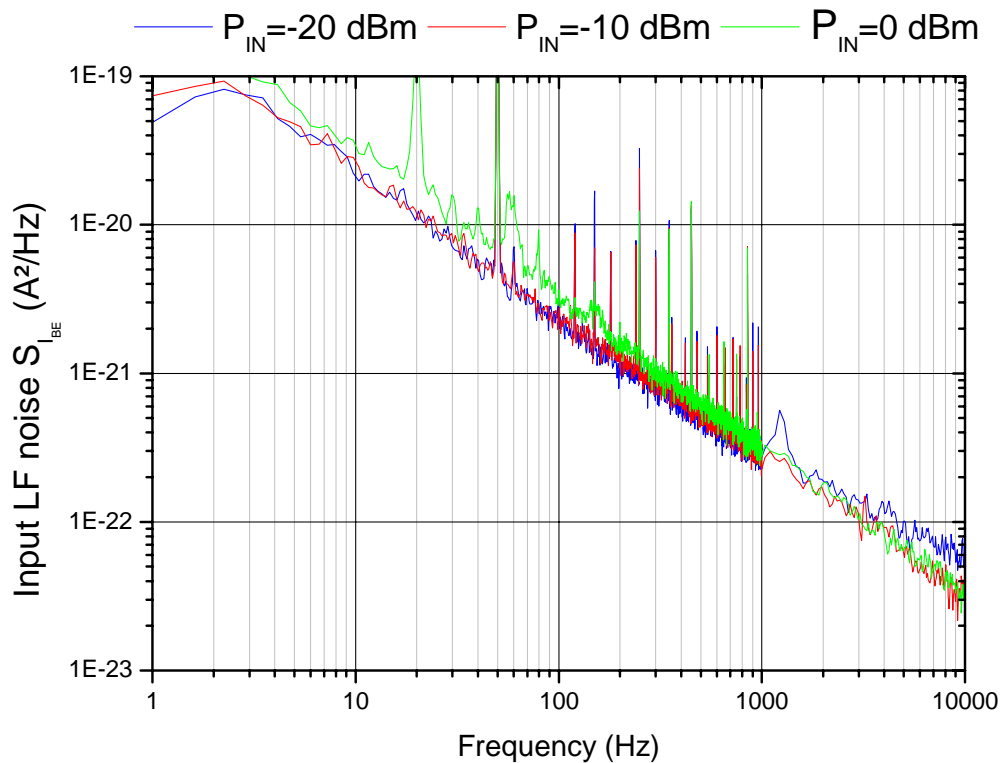

Equivalent input current noise  $S_{I_{be}}$

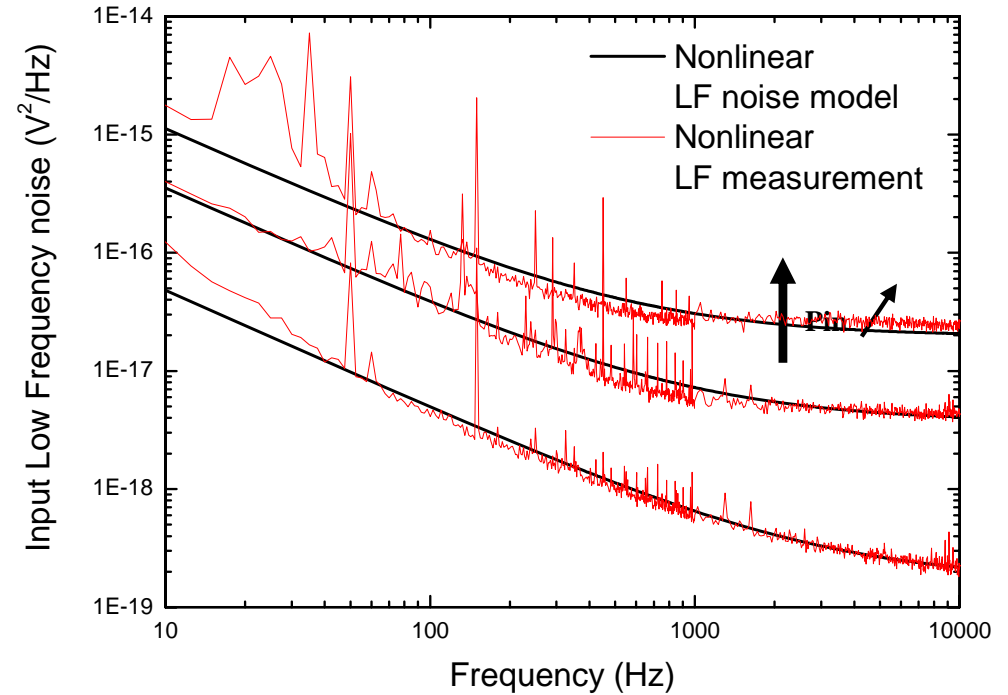

Equivalent input voltage noise  $S_{V_{be}}$

$$k_1 = a_1 * \left( e^{\left( \frac{P_{in}}{b_1} \right) - \frac{1}{c_1}} \right) \quad k_2 = a_2 * \left( e^{\left( \frac{P_{in}}{b_2} \right) - \frac{1}{c_2}} \right)$$

$$S_V(P_{in}) = \left( S_V \frac{1}{f} + k_1(P_{in}) * S_{V \text{ floor}} \right) * (1 + k_2(P_{in}))$$



# First approach used : RF power dependent external voltage noise source

SiGe HBT @ 1 dB compression point

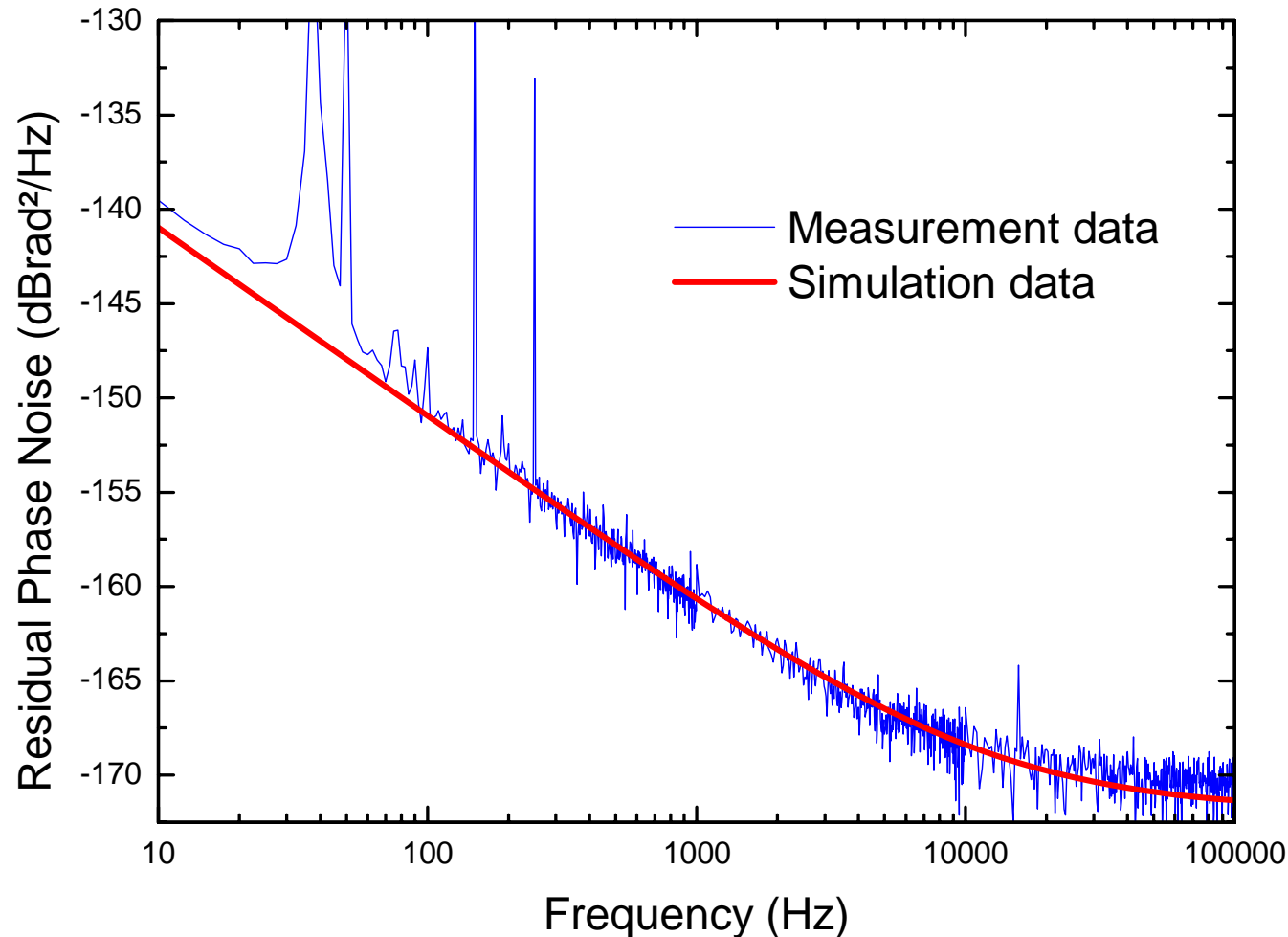

**HBT Gummel-poon model,  
using a nonlinear external LF voltage noise source**

Works very well to simulate the HBT phase noise behaviour, when the RF load is close to  $50 \Omega$  (*conditions in which the power dependent model is extracted*)

But what would happens if the RF load changes in the final circuit design ?

→ **need for an intrinsic description of the nonlinearity of the  $S_{Vbe}$  noise source**

# Second approach used : nonlinear collector current noise source

Agilent ADS software modelling

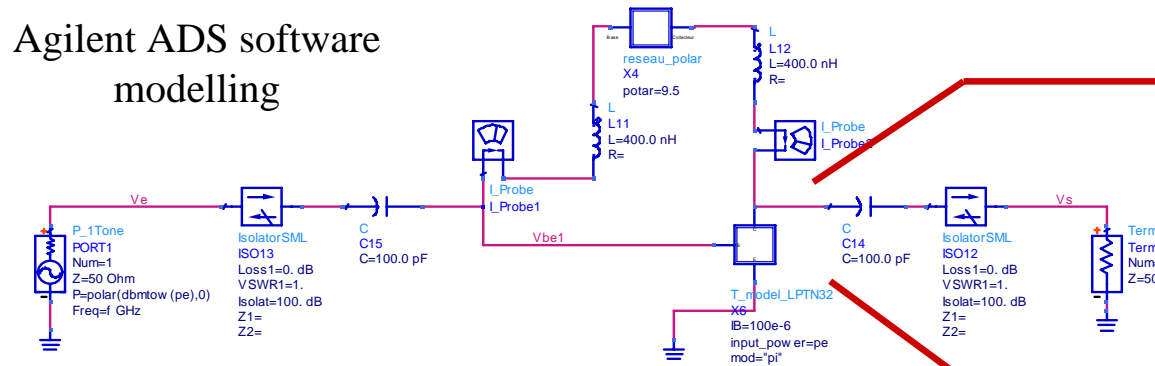

HBT nonlinear model

Nonlinear noise source defined versus instantaneous RF collector current value added to the nonlinear model thanks to SDDP element in Agilent ADS

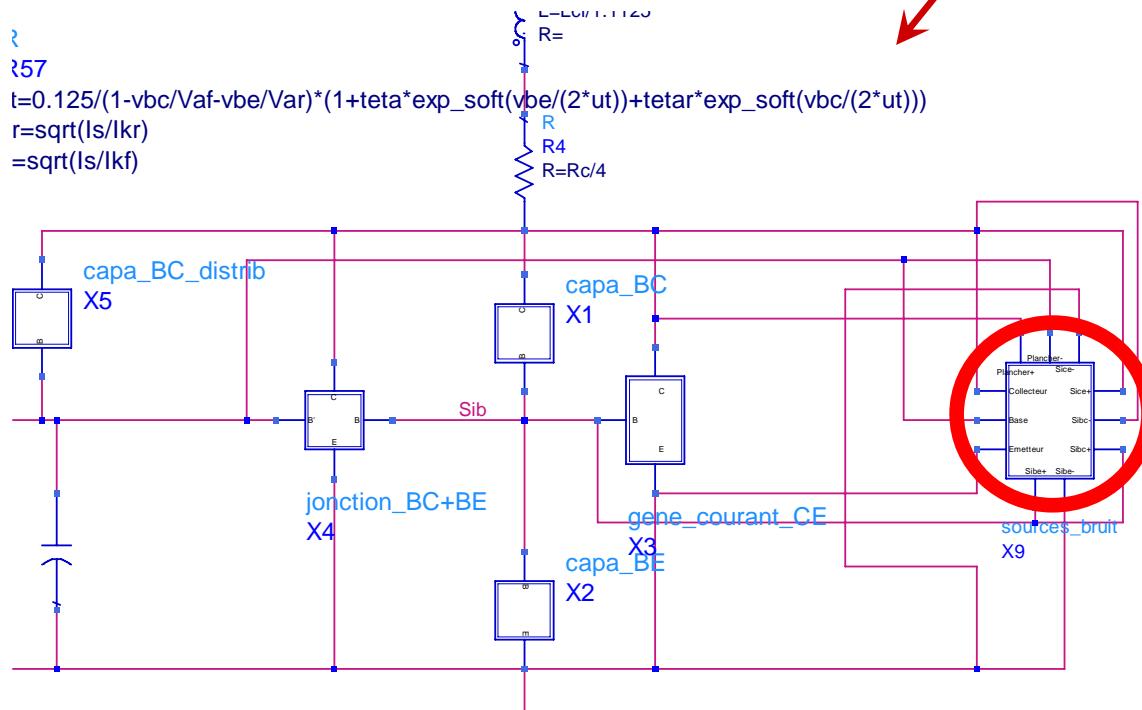

Base emitter current noise source and emitter voltage noise source are also included within the SDDP, but as constant noise sources

## Second approach used : nonlinear collector current noise source

### Model validation

3.5 GHz phase noise at three different input power levels

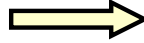

3.5 GHz phase noise with different LF base impedances

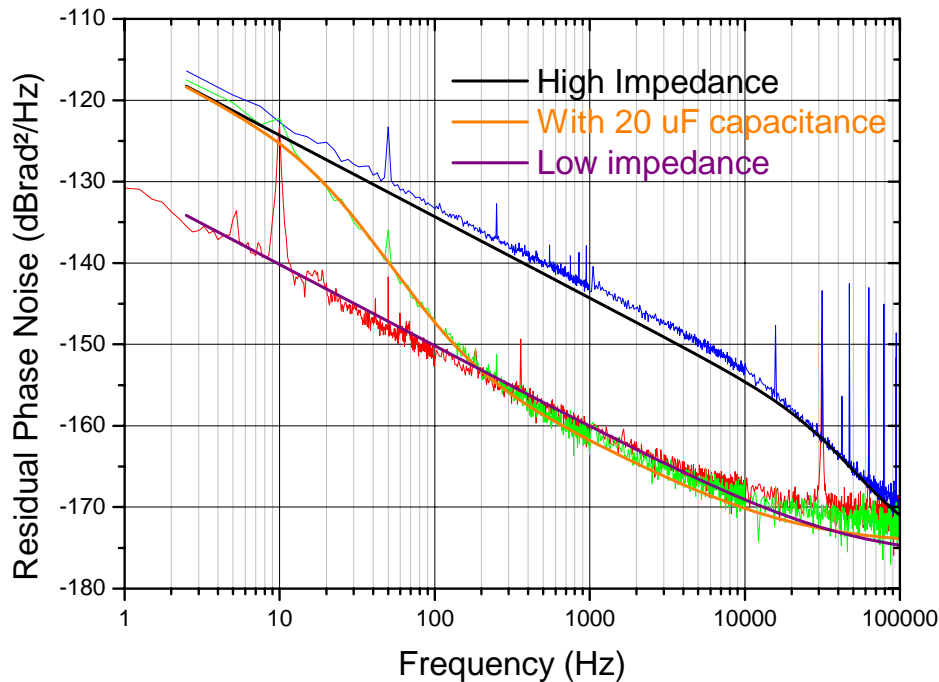

Comparison between measurements and modelling for a BFP620 with  $I_c=10\text{mA}$  and three different LF bias impedances

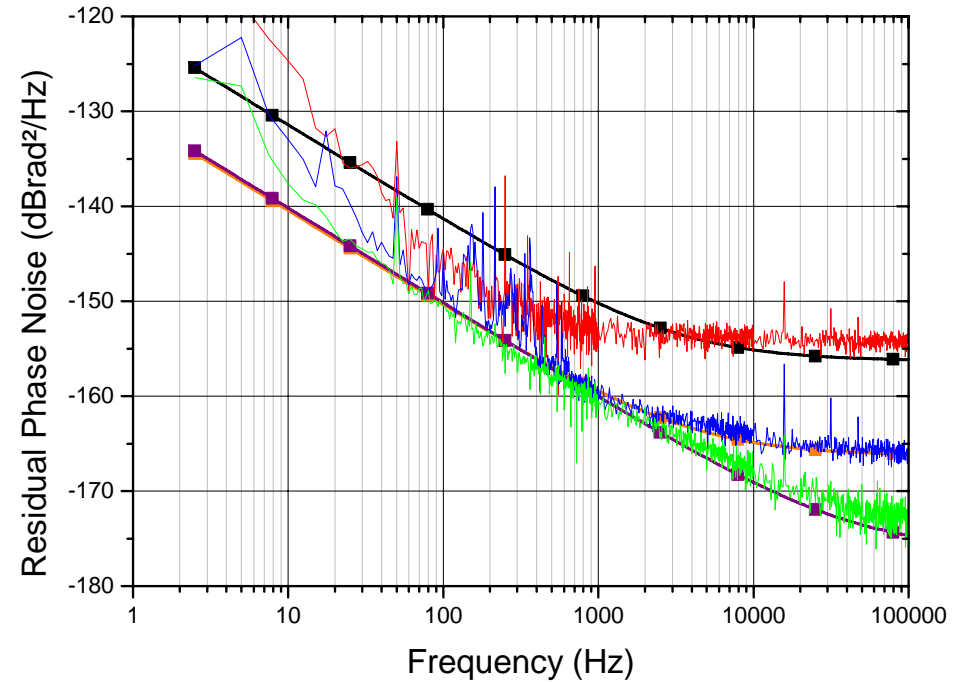

Comparison between measurements and modelling for a BFP620 with  $I_c=10\text{mA}$  and  $-20\text{dBm} < P_{in} < 0\text{ dBm}$

**Good agreement found with the nonlinear noise approach**

Further work :

Investigations on the nonlinear effect on the extrinsic  $S_{V_{be}}$  (difficult to simulate)

Correlation to the device physical parameters

## Application example : X band low phase noise amplifier

9.6 GHz two stages low  
phase noise amplifier

SiGe HBT + Si BJT

8.2 dB Power Gain  
-163 dBrad<sup>2</sup>/Hz @ 10 kHz

Application : oscillation  
on a sapphire resonator

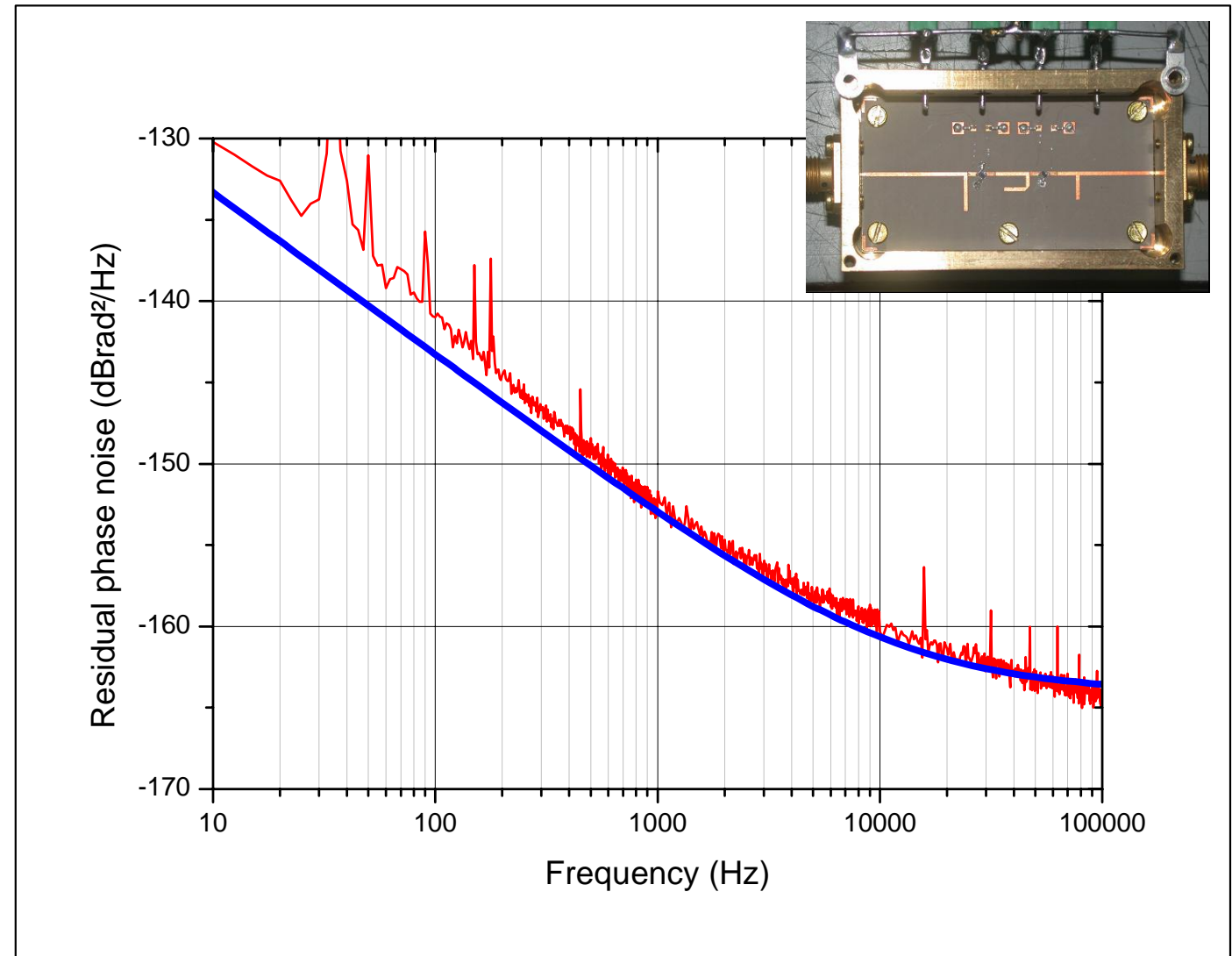

*Simulation : intrinsic nonlinear noise source*

*Comparison with a low phase noise commercially available amplifier*

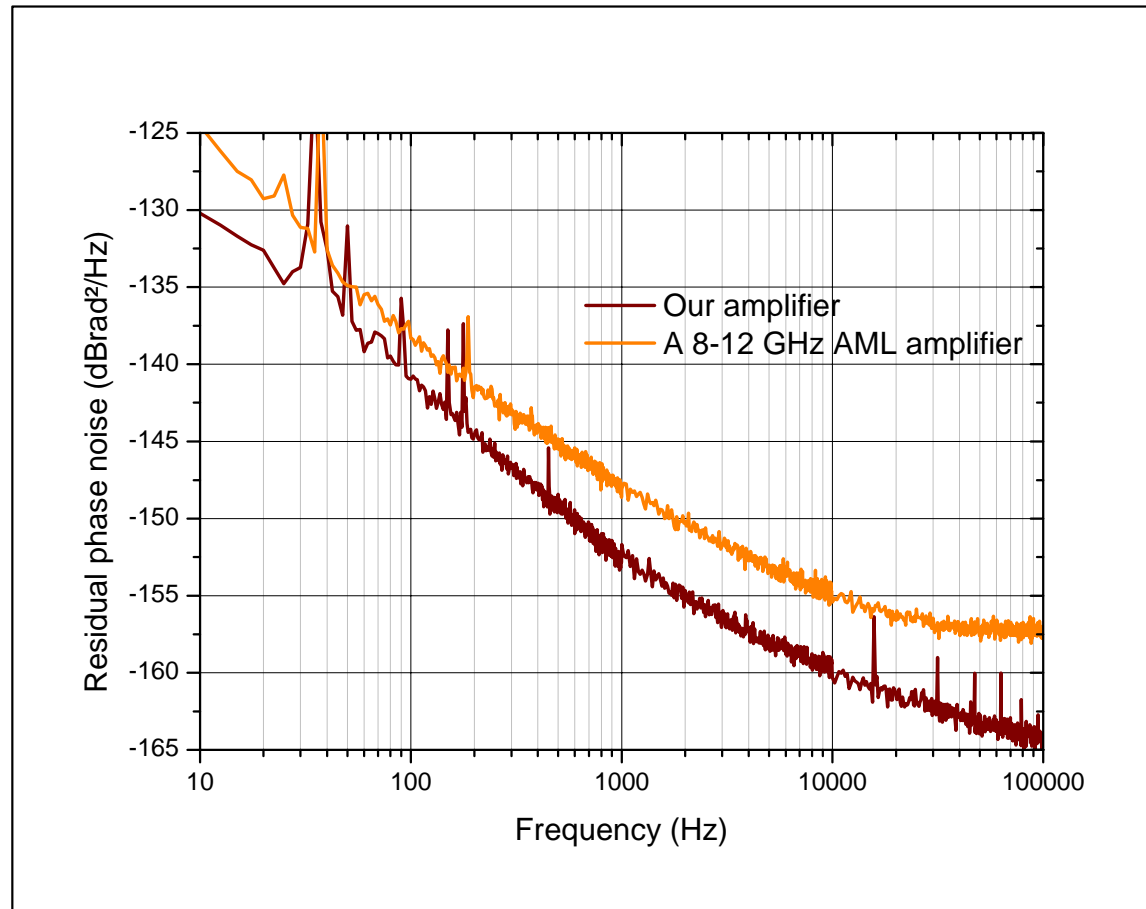

Our X band amplifier :

G = 8.2 dB

Power consumption = 2V, 20 mA

*Designed to oscillate on a resonator with  
6 dB coupling*

AML X band amplifier :

G = 24 dB

Power consumption = 15V, 600 mA

*Designed to amplify low level low phase  
noise signals*

*Thank you for your attention*