



HAL
open science

Multiport Vector Network Analyzer Configured in RF Interferometric Mode for Reference Impedance Renormalization

Kamel Haddadi, Etienne Okada, K. Daffe, F. Mubarak, Didier Theron, Gilles Dambrine

► **To cite this version:**

Kamel Haddadi, Etienne Okada, K. Daffe, F. Mubarak, Didier Theron, et al.. Multiport Vector Network Analyzer Configured in RF Interferometric Mode for Reference Impedance Renormalization. 2019 IEEE/MTT-S International Microwave Symposium - IMS 2019, Jun 2019, Boston, France. pp.1276-1278, 10.1109/MWSYM.2019.8700783 . hal-02328441

HAL Id: hal-02328441

<https://hal.science/hal-02328441v1>

Submitted on 23 Oct 2019

HAL is a multi-disciplinary open access archive for the deposit and dissemination of scientific research documents, whether they are published or not. The documents may come from teaching and research institutions in France or abroad, or from public or private research centers.

L'archive ouverte pluridisciplinaire **HAL**, est destinée au dépôt et à la diffusion de documents scientifiques de niveau recherche, publiés ou non, émanant des établissements d'enseignement et de recherche français ou étrangers, des laboratoires publics ou privés.

Multiport Vector Network Analyzer Configured in RF Interferometric Mode for Reference Impedance Renormalization

K. Haddadi^{#1}, E. Okada[#], K. Daffé[#], F. Mubarak^{\$2}, D. Théron[#], G. Dambrine[#]

[#] Univ. Lille, CNRS, UMR 8520 - IEMN, F-59000 Lille, France

^{\$} The Dutch Metrology Institute (VSL), 2600 AR Delft, Netherlands

¹kamel.haddadi@univ-lille.fr, ²FMubarak@vsl.nl

Abstract— A novel active microwave interferometric technique is implemented on a multiport vector network analyzer for renormalizing the reference impedance 50 Ohms into any desired complex impedance. The resulting measured reflection coefficient around the new reference impedance is around zero, resulting in high measurement sensitivity. The method proposed avoids any external component commonly found in interferometric set-ups. In addition, a zeroing process including vector calibration is developed for broad frequency range and requires only a software procedure to be implemented in the system framework.

Keywords— multiport vector network analyzer, microwave interferometry, extreme impedance, vector calibration.

I. INTRODUCTION

Vector network analyzers (VNA) have been introduced in the sixties to measure the electrical properties of microwave devices and circuits [1]-[2]. Since then, there has been considerable work to extend their measurement capabilities such as frequency coverage from low RF to hundreds of GHz, multi-port devices characterization, balanced, differential, harmonic, modulation and pulsed measurements. In addition to these advances in the field of vector network analysis, there is an urgent need to further extend the measurement capabilities to meet the specific needs of characterization tools for impedances clearly higher than the 50 Ω reference impedance of the VNA [3]. In particular, the electrical characterization of high impedance nanodevices in the microwave regime is still challenging [4]-[11].

Among the solutions, the interferometric principle commonly used in optics through Michelson or Mach Zender configurations has gained the interest from the microwave research community to measure small complex impedance contrasts. Basically, a monochromatic signal is split with one part traveling a fixed path and the other a variable one. The two resulting signals are reunited, amplified if necessary, and produce the well-known interference. In this effort, this paper proposes for the first time a complete interferometric solution in a broad frequency range that requires only a multiport VNA. In other words, the interferometric process is built inside the VNA itself and requires only software resource for its configuration. The method can be implemented easily in any multiport VNA. The principle of operation and methodology are described in Section II. In Section III, the interferometric configuration including calibration is proposed and validated experimentally.

II. BRIEF STATE OF THE ART

To situate the contribution of the proposed work, main related achievements are described in the following and practical limitations are highlighted. In 1949, a Michelson-type microwave interferometer is introduced for the first time at the free-space wavelength of 3.2 cm for free-space dielectric characterization [12]. In 1960, a microwave Fabry Perot interferometer at wavelengths around 6 mm is described for frequency or complex permittivity measurements [13]. In 1970, broadband frequency operation in the range 8.12-12 GHz is achieved by inserting a variable phase-shifter in the interferometer architecture [14]. In the early 1980s, microwave interferometry is applied to material thickness [15] and short distance [16] precise measurements. In 2007, microwave interferometry is applied for the first time to the measurement of high impedance devices around 1.8 GHz [17]. In 2011, a mechanical tunable interferometric matching network in the range 1-18 GHz is described [18]. In 2015, an I/Q-mixer-based interferometric technique is developed for speed operation and noise reduction [19]. In 2017, an active interferometric method using the internal sources of a multiport VNA and an external coupler is introduced [20]. These studies have proven that RF interferometric techniques are candidates to tackle the problem of impedance mismatch in a variety of applications. Nevertheless, although efforts have been made to automate the instrumentation and simplify the measurement protocols, conduct such experiments remains a heavy task.

III. INTERFEROMETRIC MODE FOR VNA

Fig. 1 depicts the architecture of the multiport VNA. We connect a reflective dipole at Port 4 with reflection coefficient named Γ_{source} ; this dipole is assumed to be unknown. We propose to choose in this work a ‘Short’ standard. This dipole only fixes the ratio b_4/a_4 which is assumed to remain constant when we modify the dipole at the ‘Measurement Port’. The wave quantities a_1 , b_1 , a_4 and b_4 correspond to the microwave signals measured at Ports 1 and 4 respectively. The microwave interferometry mode is achieved by modification of external strapping VNA connections as presented in Fig. 1. In this configuration, the Port 1 is the ‘Measurement Port’ and Port 4 is the ‘Reference Source Port’. The internal coupler of Port 3 is used to combine the reflected waves flowing from the DUT (Port 1) and from the reference load (Port 4). And finally, the receiver at Port 2 (noted ‘B’ in Fig. 1) is used to measure the wave flowing from Port 3.

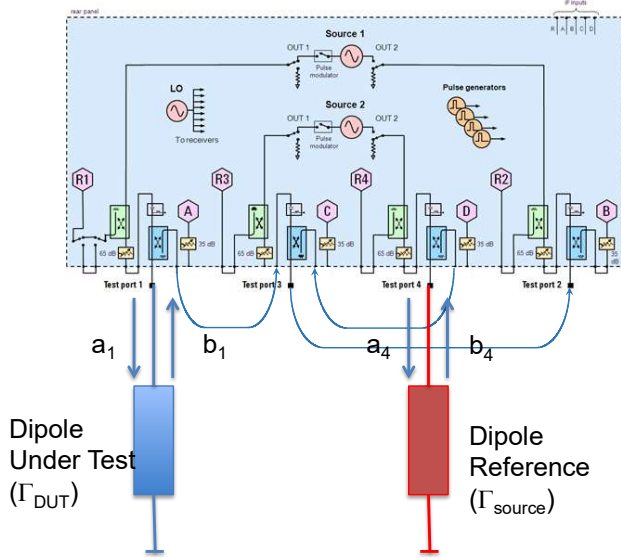

Port1: Measurement Port (DUT) Port4: Reference Source Port

Fig. 1. Synoptic of VNA in interferometer configuration. (from @Keysight Technology).

The interferometric procedure consists in the following steps:

STEP 1: Connect a one-port reference device at Port 1 with complex reflection coefficient $\Gamma_{ref} = b_1/a_1$. This reference device will determine the origin of Smith Chart.

STEP 2: Turn OFF/ON alternatively sources 1 and 4 to measure the quantities S_{21} and S_{24} respectively. We define the complex quantity Ψ (1). We note that the VNA is not calibrated.

$$\Psi = -\frac{S_{21}}{S_{24}} \quad (1)$$

STEP 3: Tune the magnitude and the phase of a_4 with respect to a_1 by the complex quantity Ψ . The total resulting signal b measured at port B with both RF sources 1 and 4 ON corresponds to

$$b = S_{21}a_1 + S_{41}\psi a_1 = 0 \quad (2)$$

In this configuration, the total emerging wave on port 2 is zero resulting in high sensitivity when measuring a complex reflection close to Γ_{ref} . It is important to mention that the zeroing condition is directly obtained by only measuring S_{21} and S_{41} . If we measure these quantities over a frequency range, we are able to perform the zeroing procedure for the whole frequency points. Compared to microwave interferometers, any tuning of variable attenuator and/or phase-shifter is required to perform this zeroing stage.

IV. EXPERIMENTAL IMPLEMENTATION

The photography of the test-set is represented in Fig. 2. The measurement bench involves a four port @PNA (10MHz-26.5

GHz) from @Keysight. A 2.92 mm coaxial Short standard is connected at Port 4 via a 2.92 mm flexible coaxial cable. The instrument state of the VNA is following: $F_{start} = 1.45\text{GHz}$; $F_{stop} = 1.55\text{GHz}$; the number of frequency points is set to 401; IF bandwidth = 100Hz; the initial power of the two internal microwave sources is fixed to -5dBm. The device under test (DUT) is built up with mechanical attenuator, phase shifter and short to cover a wide range of impedances. The DUT is connected to Port 1. We chose an impedance of 330 Ω to perform the zeroing at 1.5GHz; the magnitude and phase of the quantity Ψ are 12.31dB and -196.06° respectively.

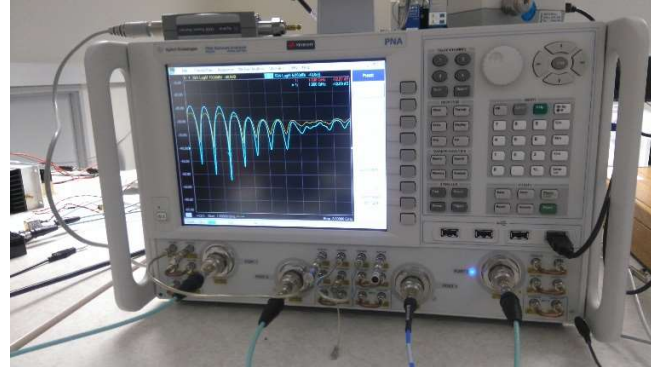

Fig. 2. Photography of VNA in interferometer configuration.

We generate eight resistive impedances between 25 Ω to 1000 Ω ; these impedances are preliminary measured using the VNA in conventional configuration and the corresponding mechanical positions of the attenuator and the phase shifter are recorded. In Fig. 3 (a), we represent the magnitude in dB versus frequency of the reflection coefficient (Γ) of several impedances. Fig. 3 (b) depicts the magnitude in dB of B/R4 versus frequency for the same impedance when the VNA is in interferometer configuration. Finally, Fig. 3 (c) represents the magnitude of S_{11} and B/R4 versus the resistance values. The values of B/R4 or B/R1 can be also calibrated using one-port procedure.

To summarize, these results prove that it is possible to realize an auto-zeroing based microwave interferometer using only a multiport VNA without external devices. Indeed, data presented in Fig. 3 demonstrate renormalization of the reference impedance to 330 Ω . In the example proposed, we have chosen a real impedance (phase-shifter is used to keep the phase-shift to of the reflection coefficient phase-shift to 0°) but the reference impedance can be chosen to any desired impedance (real, imaginary or complex).

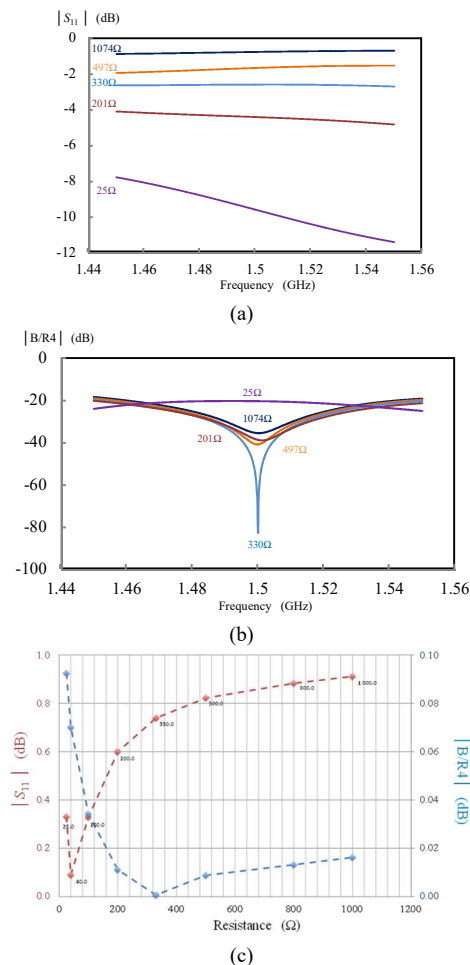

Fig. 3. Magnitude of calibrated S_{11} in dB versus frequency; (b) Magnitude of $B/R4$ in dB versus frequency; (c) Magnitude of calibrated S_{11} (linear) and magnitude of $B/R4$ (linear) versus the real part of impedances.

V. CONCLUSION

A multiport vector network analyzer configured in interferometric mode is proposed to renormalize the standard reference impedance 50Ω into any desired impedance. The technique does not require any additional microwave component. The main feature of the present work is that it is possible by including a new option in the firmware to propose a new broadband interferometer based one-port calibration procedure including the auto-zeroing technique. Indeed, vector network analyzers use narrowband tuned receivers to perform measurement frequency point by frequency point. Therefore, the interferometric process can be implemented for each frequency point to provide broad frequency coverage. From the hardware point of view, main limitations in the field of microwave interferometry, beyond the scope of this paper, are the phase noise of the sources and receivers noise. Such implementation will be investigated in further study.

ACKNOWLEDGMENT

This work is performed under EMPIR Planarcal project (<http://www.planarcal.ptb.de>). This work has received funding

from the European Union Horizon H2020 Programme (H2020-NMBP07-2017) under grant agreement n°761036 MMAMA. This work used the facilities within the EQPX ExCELSIOR (www.excelsior-ncc.eu) funded by the National Research Agency (ANR).

REFERENCES

- [1] "An advanced new network analyzer for sweep measuring amplitude and phase from 0,1 to 12.4 GHz," *HP Journal*, Feb 1967.
- [2] D. Rytting, "ARFTG 50 year network analyzer history," *2008 71st ARFTG Microwave Measurement Conf.*, pp. 1-8, Atlanta, GA, USA.
- [3] H. Happy, K. Haddadi, D. Théron, T. Lasri, and G. Dambrine, "Measurement techniques for RF nanoelectronic devices : new equipment to overcome the problems of impedance and scale mismatch," *IEEE Microwave Magazine*, vol. 15, no. 1, pp. 30-39, Jan. 2014.
- [4] P. Rice, T. M. Wallis, S. E. Russek, and P. Kabos, "Broadband electrical characterization of multiwalled carbon nanotubes and contacts," *Nano Lett.*, vol. 7, no. 4, pp. 1086-1090, Mars 2007.
- [5] The International Technology Roadmap for Semiconductors (ITRS), 2013.
- [6] A. Imtiaz, T. M. Wallis and P. Kabos, "Near-Field Scanning Microwave Microscopy: An Emerging Research Tool for Nanoscale Metrology," in *IEEE Microwave Magazine*, vol. 15, no. 1, pp. 52-64, Jan.-Feb. 2014.
- [7] Z. Yu and P. J. Burke, "Microwave transport in single-walled carbon nanotubes" *Nano Letters*, vol. 5, no. 7, pp. 1403-1406, July 2005.
- [8] T. Wallis, A. Imtiaz, H. Nembach, K. A. Bertness, N. A. Sanford, P. T. Blanchard and P. Kabos., "Calibrated broadband electrical characterization of nanowires," *2008 Conf. on Precision Electromagnetic Measurements Digest, Broomfield*, pp. 684-685, CO, 2008.
- [9] S. Li, Z. Yu, S.-F. Yen, W. C. Tang, and P. J. Burke, "Carbon nanotube transistor operation at 2.6 GHz," *Nano Lett.*, vol. 4, no. 4, pp. 753-756, 2004.
- [10] S. M. Anlage, V. V. Talanov, and A. R. Schwartz, "Principles of near-field microwave microscopy," *Scanning Probe Microscopy: Electrical and Electromechanical Phenomena at the Nanoscale*, S. Kalinin and A. Gruverman, Eds. New York, Springer Sci., pp. 215-253, Aug. 2007.
- [11] A. Imtiaz, T. M. Wallis and P. Kabos, "Near-Field Scanning Microwave Microscopy: An Emerging Research Tool for Nanoscale Metrology", *IEEE Microwave Magazine*, vol.15, no.1, pp.52-64, Jan. 2014.
- [12] B. A. Lengyel, "A Michelson-Type Interferometer for Microwave Measurements," in *Proceedings of the IRE*, vol. 37, no. 11, pp. 1242-1244, Nov. 1949.
- [13] W. Culshaw, "High Resolution Millimeter Wave Fabry-Perot Interferometer," in *IRE Transactions on Microwave Theory and Techniques*, vol. 8, no. 2, pp. 182-189, March 1960.
- [14] O. Gehre, "A Microwave Interferometer for Wide-Band Measurements of Complex Transmission Coefficients," in *IEEE Transactions on Instrumentation and Measurement*, vol. 19, no. 1, pp. 14-17, Feb. 1970.
- [15] Y. Ashkenazy, E. Levine and D. Treves, "A simple microwave interferometer for measuring effective thickness of dielectric slabs," in *IEEE Transactions on Instrumentation and Measurement*, vol. IM-30, no. 4, pp. 243-247, Dec. 1981.
- [16] A. Thansandote et al, "Microwave interferometer for measurements of small displacements," in *IEEE Transactions on Instrumentation and Measurement*, vol. IM-31, no. 4, pp. 227-232, Dec. 1982.
- [17] M. Randus, and K. Hoffmann, "A simple method for extreme impedances measurement," 2007 ARFTG Int. Conference. December 2007.
- [18] Haddadi, K., Glay, D., Lasri, T. (2011). Near-field scanning microscopy in liquid media based on microwave interferometry. In 9th International Conference on Electromagnetic Wave Interaction with Water and Moist Substances, ISEMA 2011 (pp. 185-192).
- [19] G. Vlachogiannakis et al, "An I/Q-mixer-steering interferometric technique for high-sensitivity measurement of extreme impedances," 2015 IEEE MTT-S International Microwave Symposium, Phoenix, AZ, 2015, pp. 1-4.
- [20] H. Votsi, Li Chong, P. H. Aaen and N. Ridler, "An active interferometric method for extreme impedance on-wafer device measurements," *IEEE Microw. Compon. Lett.*, vol. 27, no. 11, pp. 1034-1036, Nov. 2017.