



**HAL**  
open science

## **Study of carbon dioxide capture from industrial incinerator flue gas on a laboratory scale pilot**

Ismaël Aouini, Alain Ledoux, Lionel Estel, Soazic Mary, Julien Grimaud, Benoit Valognes

### ► **To cite this version:**

Ismaël Aouini, Alain Ledoux, Lionel Estel, Soazic Mary, Julien Grimaud, et al.. Study of carbon dioxide capture from industrial incinerator flue gas on a laboratory scale pilot. Energy Procedia, 2011, 4, pp.1729-1736. <10.1016/j.egypro.2011.02.047>. <hal-02328230>

**HAL Id: hal-02328230**

**<https://hal.science/hal-02328230v1>**

Submitted on 31 May 2021

**HAL** is a multi-disciplinary open access archive for the deposit and dissemination of scientific research documents, whether they are published or not. The documents may come from teaching and research institutions in France or abroad, or from public or private research centers.

L'archive ouverte pluridisciplinaire **HAL**, est destinée au dépôt et à la diffusion de documents scientifiques de niveau recherche, publiés ou non, émanant des établissements d'enseignement et de recherche français ou étrangers, des laboratoires publics ou privés.



Distributed under a Creative Commons CC BY 4.0 - Attribution - International License

GHGT-10

## Study of carbon dioxide capture from industrial incinerator flue gas on a laboratory scale pilot

Ismael Aouini<sup>a</sup>, Alain Ledoux<sup>a\*</sup>, Lionel Estel<sup>a</sup>, Soazic Mary<sup>b</sup>, Julien Grimaud<sup>b</sup>, Benoit Valognes<sup>b</sup>

<sup>a</sup>LSPC, INSA de Rouen, Avenue de l'université, 76800 Saint Etienne du Rouvray, France

<sup>b</sup>Veolia Environnement, 36 Avenue Kleber, 75016 Paris, France

---

### Abstract

The paper presents a study of carbon dioxide capture from industrial incinerator flue gas on a laboratory scale. It first offers the project context and the incinerator gas features. Starting from these specificities, we propose a tool for evaluating the sustainability of carbon dioxide (CO<sub>2</sub>) capture with alkanolamine processes from incinerator flue gas and we chose the formulation of 30 %wt of monoethanolamine (MEA) in water as benchmark solvent.

A summary of previous studies is presented for the solvent degradation and the experimental setups. The data needs were identified for a consistent evaluation of the CO<sub>2</sub> capture from incinerator flue gas and an innovative pilot was designed to conduct the study. We present a detailed description of the experimental facility and analytical methods and we focus on the innovative features of the setup:

- A multipurpose tool for large parametric studies of process performance (energy cost and capturing efficiency) vs. process specification and input gas composition.
- A degradation measurement setup which complete previous works by studying degradation mechanisms in a full process loop and with corrosion control.

© 2011 Published by Elsevier Ltd. Open access under [CC BY-NC-ND license](https://creativecommons.org/licenses/by-nc-nd/4.0/).

"Keywords: Carbon dioxide; monoethanolamine; pilot test; incinerator flue gas; post-combustion capture;"

---

### 1. Introduction :

Greenhouse gases such as carbon dioxide (CO<sub>2</sub>) have caused global warming over the last century and their effects will be more significant in the future [1]. In 2009, Veolia Environnement emitted about 44 Mt of CO<sub>2</sub> eq through their four branches (energy, water, waste and transport). Therefore, the purpose of Veolia Environnement is to reduce greenhouse gas emissions and more specifically CO<sub>2</sub> emission. Accordingly, an R&D program was launched in 2005 including the CO<sub>2</sub> capture and reuse and in this context a study about the sustainability of carbon

dioxide capture from a hazardous incinerator flue gas using alkanolamines processes started in 2007. It involves Veolia Environnement as the industrial partner and LSPC research laboratory as the academic partner.

From a technological point of view, decarbonisation of gas streams has been feasible since several decades using chemical absorption by alkanolamine solvents. Khol and Nielsen [2] have provided a comprehensive summary of the theory and the technological aspects. They present the range of the solvent formulation and equipment design vs. the process target and the CO<sub>2</sub> source properties.

On the other hand, the CO<sub>2</sub> compression and its storage come at significant cost and reusing it as raw material for a local plant or a neighbourhood industry is more relevant (industrial ecology). The CO<sub>2</sub> can be immediately used as chemical in a large range of applications (carbonatation, precipitation, neutralization, etc.) depending on the purity of the product. In 2009, Rouzineau [3] established that the overall CO<sub>2</sub> consumption as raw material is about 155 Mt/y with 40 Mt/y for the Enhanced Oil Recovery (EOR), 15 Mt/y for food industries and 100 Mt/y for chemical industries. The reuse option is economically feasible if the CO<sub>2</sub> source is close to the market and if the CO<sub>2</sub> extracted has a high purity (>99.9% typically).

This study first aims at evaluating the sustainability of carbon dioxide alkanolamine capture from incinerator flue gas including reuse option. The process target is to provide a CO<sub>2</sub> stream with commercial purity and minimum investing and operating cost. Incinerator flue gas has low CO<sub>2</sub> partial pressure, is high in oxygen (O<sub>2</sub>), and contains pollutants which may react with solvent and dust fines. We select monoethanolamine (MEA) as the solvent as it is the most appropriate for low CO<sub>2</sub> partial pressure extraction [2]. To start with, we choose the formulation of 30 %wt of MEA in water as the benchmark solvent due to the large amount of data available on this solvent.

A lot of studies about the CO<sub>2</sub> extraction from coal and gas power plants have been made over the last years. They were a good starting point for this study because incinerator and power plant flue gases present several similarities. However, those studies focus on the energy consumption as process target and CO<sub>2</sub> extracted purity is not profoundly evaluated vs. gas composition input. Moreover, we found a lack of data concerning the interaction between pollutants and solvents. No experiments currently evaluate the sustainability of the alkanolamine processes for the incinerator case.

## 2. Previous works:

### 2.1. Solvent degradation:

Comprehensive studies concern the stability of 30%wt MEA solvent with coal or gas power plant flue gas. The compositions of these flue gases diverge from the incinerator flue gas. Nevertheless, those data were useful to identify the following degradation mechanisms of MEA in our study:

Thermal degradation: Davis and Rochelle [4] have provided a comprehensive analysis of the thermal degradation of MEA including a bibliographical summary and an experimental study. Those reactions take place mainly in the stripper section of the process and may correspond to carbamate polymerization according to Polderman et al. [5] and Yazvikova et al. [6]. Strazisar et al. [7] have found products of those mechanisms in an industrial CO<sub>2</sub> capture plant using MEA solvent. Davis and Rochelle conclude that thermal degradation kinetics strongly depends on the stripper operating temperature and could be limited if it does not exceed 110°C. For the incinerator flue gas, this has to be corroborated by experiments.

Oxidative degradation: Like the coal power plants, incinerator flue gas has a non negligible fraction of O<sub>2</sub> and it has been proved that MEA has strong interaction with oxygen [8]. A number of papers deals with the oxidative degradation of MEA and several pathways are suggested. Starting from parametric batch experiments at high temperature and with high O<sub>2</sub> pressure, Bello and Idem [9] have identified for each test from 10 to 30 oxidative mechanisms and products. These large amounts of components could be explained by the deviation between the experimental conditions and the process specifications. It exhibits the sensitivity of the chemistry system. Sexton

and Rochelle [10] have worked closer to the absorption conditions. They find that ammonia is the major product in the gas phase and organic acids are strongly present in the liquid phase. They also demonstrate the metal catalysis of the reaction. Bedell [11] proposes a pathway using radical mechanisms for the oxidative degradation. As summarized on figure 1, the metal cation reacts with oxygen to generate radicals which attack the MEA molecules. The metal cation is then regenerated by the water for a new cycle of reaction. For the incinerator flue gas, this has to be corroborated by experiments. Pollutants and dust fines could have an impact on the kinetics.

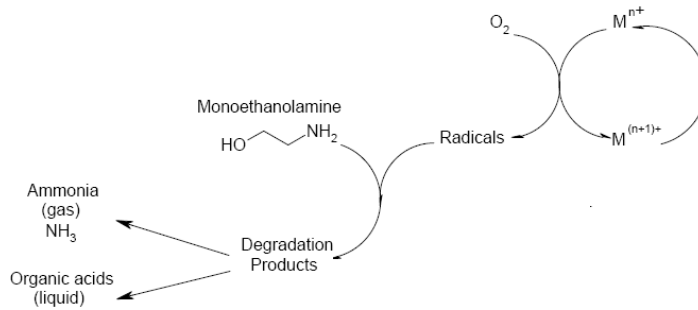

Figure 1: Simplified pathway of MEA oxidative degradation

**Corrosion:** The previous paragraph shows the strong interaction between metal presence in the solvent and the oxidative degradation. One of the major sources of metal comes from the corrosion of the facilities. Veawab and al. [12] present the significance of the corrosion problem in alkanolamines processes and Dupart et al. [13] detail its impact on the facilities. They also reveal that the corrosion stability of the solvent depends strongly on the gas stream composition. For incinerator flue gas, it is expected that, in presence of oxygen, monoethanolamine degradation generates acid molecules. Rooney et al. [14] prove that acids increase the corrosiveness of alkanolamine solvents, which increases the metal concentration in the solvent. Furthermore, some pollutants like chloride are well known as corrosion agents. Therefore, corrosion and degradation runaway is expected if an appropriate solution is not implemented. For the incinerator flue gas, this has to be corroborated by experiments.

**Heat stable salts:** The incinerator flue gas contains acidic pollutants traces. The dissolution and the hydrolysis of those components in the solvents lead to strong acids. As mentioned previously, oxidative degradation also produces strong organic acids. MEA is a weak base and react with acid (AH) to capture a proton and generate an anion (figure 2). The ion pair forms a stable salt.

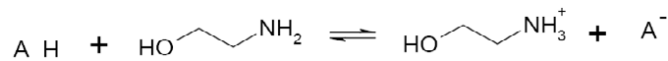

Figure 2: Mechanism pathway of MEA stable salts

When the acid is weak like the  $CO_2$  the equilibrium is reversed with a temperature increase. The reaction with strong acids is not reversible leading to heat stable salts (HSS). Accordingly, the process effectiveness decreases each time that strong acids are added to the solvent. For the incinerator flue gas, no experimental data quantify this phenomenon.

## 2.2. Experimental studies:

In 2001, Rochelle et al. [15] clearly summarized the research needs for  $CO_2$  capture by alkanolamine processes. Since then, major advances have been made for thermodynamic and kinetic models. Comprehensive simulation tools which show good performances for the 30%wt MEA solvent [16] are now available. We need experimental validation of simulation programs by pilot experiments in order to use it for incinerator flue gas treating. In addition, chemical interactions between solvent and incinerator flue gas have to be analysed for process sustainability

evaluation in long term operation. We present in this paragraph the experimental studies which we have considered designing.

*Amine degradation setups:* The current studies use the batch reactor technology. Lepaumier et al. [17] have studied several amine resistances against oxidative degradation by heating them at 140 °C with gas phase pressurized at 2 MPa in stainless steel reactors for 15 days. They draw aside from process conditions to obtain high enough amounts of amine losses to show significant differences. In the same way, Supap et al. [18] propose a kinetic expression of oxidative degradation in the presence of sulphur dioxide (SO<sub>2</sub>) starting from parametric batch experiments. They vary the oxygen partial pressure on stainless steel reactors for a temperature range from 55°C to 120°C and a total pressure of 2.5 bar. This is closer to the real process conditions but Goff and Rochelle [8] suggest that mass transfer of the experimental equipment, i.e. hydrodynamic parameters, has an impact on oxidative degradation kinetics. Therefore, they used a batch reactor with a constant bubbling of gas at absorption temperature and pressure conditions. They measured the amount of ammonia in the gas reactor outlet to quantify the degradation kinetic. Currently, no parametric studies evaluate the MEA degradation with the full process loop and with analogous hydrodynamic conditions to industrial columns. The pilot setups mentioned below do not control input gas composition. Previous studies did not check the evolution of the physicochemical properties of the solvent vs. the degradation amount. Those properties have a direct impact on the efficiency of the process extraction.

*Pilots:* In the multipurpose pilot at the International Test Centre for CO<sub>2</sub> Capture (ITC), Idem et al. [19] provided a good illustration of how to optimize the design and measuring equipments for process evaluation. The set up was made in steel and the input gas stream comes from a gas steam boiler and has no pollutants. The study focused on the energy consumption minimization but the authors have not presented MEA degradation measurements. Similarly and on a much larger scale, the CASTOR pilot [20] measures the energy performance of several alkanolamine solvents. The gas stream comes from a pulverized coal-fired power station. They have studied the solvent degradation by measuring the concentration evolution of the amine solvent and the heat stable salts formation. The pollutant impact is partly checked by monitoring the SO<sub>2</sub> overall mass balance. For 30%wt MEA solvent tests, detailed emission measurements have been conducted to check the quality of the CO<sub>2</sub> extracted stream and they detect several impurities. The previous studies didn't check the evolution of physicochemical properties of the solvent and no pilot studies were performed on incinerator flue gas.

### 2.3. The data needs:

Starting from the previous literature review, we identify the following data needs to achieve consistent evaluation of the 30%wt MEA solvent for CO<sub>2</sub> extraction from incinerator flue gas:

- Experimental evaluation of process efficiency of the 30%wt MEA solvent for the incinerator flue gas
- Pilot study with parametric evaluation of process efficiency vs. input gas composition
- Variation of CO<sub>2</sub> extracted purity vs. process specifications
- Validation of simulation tools for the incinerator flue gas treating
- Parametric study of MEA degradation with full process loop and with analogous hydrodynamic conditions to industrial columns
- Evaluation of degradation rate of various mechanisms for the incinerator flue gas treating with alkanolamine solvents
- Analysis of the impact of pollutants and dust fines on process efficiency and degradation kinetics
- Pilot study without steel for uncoupling corrosion and oxidative degradation
- Measurements of the physicochemical properties of 30%wt MEA solvent with degradation products

Based on those needs, we have designed an innovative pilot setup to fill the gaps in previous studies as well as reach our goals.

### 3. Experimental setup:

#### 3.1. Design specifications:

The following specifications were established for the experimental setup starting from the data requirement and the study goals:

- Setup specifications equivalent to the industrial processes for the temperature, the pressure, the column hydrodynamic and the mass transfer coefficients
- Temperature measurement of liquid and gas input and output streams and temperature profile for each column
- Flow rate measurement of liquid and gas input and output streams for each column
- Composition measurement of liquid and gas input and output streams and composition profile for each column
- Energy balance measurement tool for each heat exchanger and desorption column
- Gas generator section which controls temperature, flow rate and gas stream composition
- No metal as raw material
- Gas analysis tools for concentration measurements of CO<sub>2</sub>, O<sub>2</sub>, pollutants, ammonia and MEA volatility
- Liquid analysis tools for MEA concentration, dissolved pollutants and organic acids
- Water balance measurement tool for the overall process
- Automatic control of pilot setup for long term experiences and thorough data system acquisition

#### 3.2. Experimental apparatus and analytical methods:

The design starts from the classic flow diagram of alkanolamine processes and includes the previous specifications. The temperature and the pressure are equal to industrial process specifications. The hydrodynamic design calculations were validated by experimental measurements of flood points and the mass transfer characteristics were checked with CO<sub>2</sub>-NaOH experiments. The column hydrodynamic and the mass transfer conditions are similar to industrial plants. The pilot flow diagram (figure 3) is described in the following sections:

Gas flow generator: it provides the desired gas flow to the absorption column starting from pure gas cylinders. The controlled parameters are the flow rate, the temperature and the composition. The gas composition is achieved by using mass flow meters. First, the nitrogen and oxygen mixture passes through a humidifier column where hot water is injected from the top. The gas flow is saturated with water to the desired temperature outlet by controlling the hot water flow. The CO<sub>2</sub> and the pollutants are added afterwards due to their high solubility in water. An electrical heating device keeps the gas flow at the desired temperature and avoids condensation between the humidifier and the absorption columns.

Absorption column: the column is made of glass. It is about 2 m high and 0.1 m in diameter and it is filled with ceramic packing. The packing section is divided in three parts. Each one has a temperature measurement, a liquid sampling and two gas samplings. The gas flows from the bottom to the top and is mixed countercurrently with the MEA solvent. The CO<sub>2</sub> passes from the gas to the solvent. The lean carbon flue gas leaves the top of the column to the event. The lean solvent is injected on top and the rich solvent is sent to desorption by the rich solvent pump. Temperature, pressure, flow rate and composition of gas and solvent are measured at the bottom and at the top of the column. Before reaching the desorption column, the rich solvent goes through a heat exchanger to increase its temperature. An energy balance is done by using temperature and flow rate measurements.

Desorption column: Just like the absorption, the column is made of glass. It is about 1.5 m high and 0.1 m in diameter and it is filled with ceramic packing. The packing section is divided in three parts. Each one has a temperature measurement and a liquid sampling. The solvent flows down the packing and reaches reboiler equipment. Heat is provided through the glass wall by an electrical resistance and an energy balance is done. Two

liquid samplings give the solvent composition at the inlet and the outlet of the reboiler. The solvent temperature rises through the column and the reboiler. CO<sub>2</sub> and steam are released and flow up to the condenser. The water is condensed and the extracted CO<sub>2</sub> leaves the equipment. An energy balance is done on the condenser and a gas sampling gives the purity of outlet flow. The overall desorption pressure is controlled by proportional relief valve. On the reboiler outlet, the lean solvent is sent to the absorption column and it goes through a heat exchanger to decrease its temperature. An energy balance is done by using temperature and flow rate measurements.

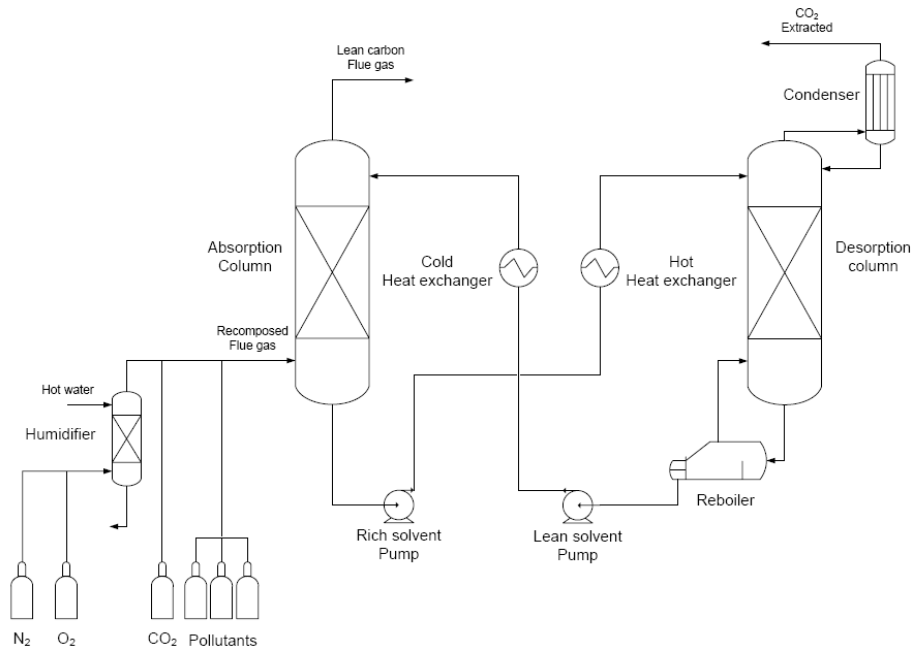

Figure 3: Process flow diagram of the laboratory pilot setup

The gas sampling system is controlled automatically with pneumatic valves. The gas sample is sent to an analyser which gives the volumetric concentration in CO<sub>2</sub>, O<sub>2</sub> and pollutants. Furthermore, the MEA volatility and the ammonia stripping are quantified from the absorption and desorption gas outlets by bubbling in 1M HCl solution. Those liquid samples are sent to cationic HPLC analysis.

The liquid samples are taken manually. A Dionex CS-11 cationic column allows the analysis of MEA and ammonia concentrations. The CO<sub>2</sub> load of the solvent is quantified by gas chromatography by using the protocol of Jou et al. [21]. A Dionex AS-23 anionic column allows the analysis of the concentration of organic acids and pollutant dissolution products. Finally, a neutral cation is added to the solvent as internal reference to check the water balance during long time experiments. It is quantified by flame photometry.

The pilot setup is controlled by a National Instrument controller using an in-house labview program. It allows getting a real-time acquisition of temperatures, pressures, flow rates, energy balances and gas composition. Those profiles are reported on screen and stored in a data acquisition system.

### 3.3. Innovative features:

**A multipurpose tool:** The setup is much smaller than ITC and CASTOR Pilots. It operates in laboratory scale which allows to use glass and plastics as raw materials. The inlet gas flow rate is sufficiently low to generate flue gas without a combustion section and it is high enough to have similar column hydrodynamic and mass transfer conditions to industrial plants. The pilot covers all the characteristics of the ITC multipurpose pilot. It allows making an accurate diagnostic of process performance for the energy cost and the capture efficiency. Like the

CASTOR pilot, the purity of the extracted CO<sub>2</sub> could be checked accurately according to process parameters. All those measurements are performed from experiments of a long duration. Therefore, the pilot provides the needed data to validate simulation tools and to make a preliminary evaluation of process sustainability. However, the gas generator section increases the flexibility of the setup. Starting from pure components, it allows the generation of several flue gas compositions and it can uncouple the impact evaluation on process efficiency of various gasses. In this respect, the setup goes beyond previous parametric studies and provides an original set of data.

Complementary degradation measurements: As previously mentioned, current degradation studies are based on batch reactor technology. The setup offers a complementary tool in that it studies degradation in a full process loop and with analogous hydrodynamic conditions to industrial columns. Moreover, corrosion phenomenon is monitored. The pilot raw materials are glass and plastic to control the metallic ion concentrations in the solvent and to uncouple the corrosion and the oxidative degradation phenomena. Adding metallic ions to the solvent simulate corrosion. Furthermore, a multipurpose configuration allows the evaluation of pollutant impact on the degradation rates and on the process efficiency. The various degradation rates are measured by a target component. Oxidative degradation is quantified by measuring the ammonia in gas stream outlets. Heat stable salts are quantified by measuring the strong acids in the solvent. The thermal degradation rate is obtained by subtracting the oxidative degradation rate and the losses caused by the volatility from the overall disappearance rate of MEA. Finally, the variation of the physicochemical properties due to the degradation is checked by a periodic liquid sampling.

#### 4. Conclusion :

The paper presents a study of carbon dioxide capture from industrial incinerator flue gas on a laboratory scale. It first offers the project context and the incinerator gas features. Starting from these specificities, we propose a tool for evaluating the sustainability of carbon dioxide (CO<sub>2</sub>) capture with alkanolamine processes from incinerator flue gas and we chose the formulation of 30 %wt of monoethanolamine (MEA) in water as benchmark solvent.

A summary of previous studies is presented for the solvent degradation and the experimental setups. The data needs were identified for a consistent evaluation of the CO<sub>2</sub> capture from incinerator flue gas and an innovative pilot was design to conduct the study. We present a detailed description of the experimental facility and analytical methods and we focus on the innovative features of the setup:

- A multipurpose tool for large parametric studies of process performance (energy cost and capturing efficiency) vs. process specification and input gas composition.
- A degradation measurement setup which complete previous works by studying degradation mechanisms in a full process loop and with corrosion control.

Currently, the pilot setup is in service and operations with nitrogen and carbon dioxide mixtures are consistent with previous data. Therefore, the acquisition data system, the balance calculations and the analytical methods are validated. Impact studies on process performance and solvent degradation are under way for various pollutants.

## 5. References:

- [1] Pachauri RK, Reisinger A. Contribution of Working Groups I, II and III to the Fourth Assessment Report of the Intergovernmental Panel on Climate Change. IPCC. 2007.
- [2] Kohl A, Nielsen R. Gas purification. 5<sup>th</sup> ed. Houston: Gulf Publishing Company; 1997.
- [3] Rouzineau D. CO<sub>2</sub> capture for chemical use. 12<sup>th</sup> Cathala-Letort conference: CO<sub>2</sub> Capture and Storage: from Dream to Reality. Lyon 2009, France.
- [4] Davis J, Rochelle GT. Thermal degradation of monoethanolamine at stripper conditions. Energy Procedia 2009; 1: 327-333.
- [5] Polderman LD, Dillon CP et al. Why monoethanolamine solution breaks down in gas treating service. Proc Gas Conditioning Conf 1955; 49-56.
- [6] Yazvikova NV, Zelenskaya LG et al. Mechanism of side reactions during removal of carbon dioxide from gases by treatment with monoethanolamine. Z Prikl Khim 1975; 48(3): 674-676.
- [7] Strazisar BR, Anderson RR, White CM. Degradation pathways for monoethanolamine in a CO<sub>2</sub> capture facility. Energy Fuels 2003 ; 17(4): 1034-1039.
- [8] Goff GS, Rochelle GT. Monoethanolamine degradation: O<sub>2</sub> mass transfer effects under CO<sub>2</sub> capture conditions. Ind Eng Chem Res 2004; 43: 6400-6408.
- [9] Bello A, Idem R. Pathways for the formation of products of the oxidative degradation of CO<sub>2</sub>-loaded concentrated aqueous Monoethanolamine solutions during CO<sub>2</sub> absorption from flue gases. Ind Eng Chem Res 2005; 44: 945-969.
- [10] Sexton AJ, Rochelle GT. Catalysts and inhibitors for MEA oxidation. Energy Procedia 2009 ; 1: 1179-1185.
- [11] Bedell SA. Amine autoxidation in flue gas CO capture: Mechanistic lessons learned from other gas treating processes. Int J Greenhouse Gas Control 2010.
- [12] Veawab A, Tontiwachwuthikul P, Chakma A. Corrosion behavior of carbon steel in the CO<sub>2</sub> absorption process using aqueous amine solutions. Ind Eng Chem Res 1999; 38: 3917-3924
- [13] Dupart MS, Bacon TR, Edwards DJ. Part 1 - Understanding corrosion in Alkanolamine gas treating plants. Hydrocarbon Processing 1993; April: 75-80.
- [14] Rooney PC, Bacon TR, Dupart MS. Effect of heat stable salts on MDEA solution corrosivity. Hydrocarbon Processing 1996; March: 95-103.
- [15] Rochelle GT, Bishnoi S, Chi S, Dang H, Santos J, Research needs for CO<sub>2</sub> capture from flue gas by aqueous Absorption/stripping. DE-AF26-99FT01029; U.S. Department of Energy-Federal Energy Technology Center: Pittsburgh, PA, 2001.
- [16] Dugas R, Alix P, Lemaire E, Broutin P, Rochelle GT. Absorber model for CO<sub>2</sub> capture by monoethanolamine: application to CASTOR pilot results. Energy Procedia 2009; 1: 103-107.
- [17] Lepaumier H, Picq D, Carrette PL. New amines for CO<sub>2</sub> capture. II. Oxidative degradation mechanisms. Ind Eng Chem Res 2009; 48: 9068–9075.
- [18] Supap T, Idem R, Tontiwachwuthikul P, Saiwan C. Kinetics of sulfur dioxide and oxygen induced degradation of aqueous monoethanolamine solution during CO<sub>2</sub> absorption from power plant flue gas streams. Int J Greenhouse Gas Control 2009; 3: 133-142.
- [19] Idem R, Gelowitz D, Tontiwachwuthikul P. Evaluation of the performance of various amine based solvents in an optimized multipurpose technology development pilot plant. Energy Procedia 2009; 1: 1543-1548.
- [20] Knudsen JN, Jensen JN, Vilhelmsen PJ, Biede O. Experience with CO<sub>2</sub> capture from coal flue gas in pilot scale: testing of different amine solvents. Energy Procedia 2009; 1: 783-790.
- [21] Jou FY, Otto FD, Mather AE. Vapor-liquid equilibrium of carbon dioxide in aqueous mixtures of monoethanolamine and methyl-diethanolamine. Ind Eng Chem Res 1994; 33: 2002-2005.