



HAL
open science

Principles of transparency for autonomous vehicles: first results of an experiment with an augmented reality human–machine interface

Raïssa Pokam Meguia, Serge Debernard, Christine Chauvin, Sabine Langlois

► To cite this version:

Raïssa Pokam Meguia, Serge Debernard, Christine Chauvin, Sabine Langlois. Principles of transparency for autonomous vehicles: first results of an experiment with an augmented reality human–machine interface. *Cognition, Technology and Work*, 2019, 21 (4), pp.643-656. 10.1007/s10111-019-00552-9 . hal-02306589

HAL Id: hal-02306589

<https://hal.science/hal-02306589v1>

Submitted on 25 Jun 2024

HAL is a multi-disciplinary open access archive for the deposit and dissemination of scientific research documents, whether they are published or not. The documents may come from teaching and research institutions in France or abroad, or from public or private research centers.

L'archive ouverte pluridisciplinaire **HAL**, est destinée au dépôt et à la diffusion de documents scientifiques de niveau recherche, publiés ou non, émanant des établissements d'enseignement et de recherche français ou étrangers, des laboratoires publics ou privés.

Principles of transparency for autonomous vehicles: first results of an experiment with an augmented reality human–machine interface

Raissa Pokam^{1,2} · Serge Debernard² · Christine Chauvin³ · Sabine Langlois^{1,4}

Abstract

Highly automated driving allows the driver to temporarily delegate the driving task to the autonomous vehicle. The challenge is to define the information that needs to be displayed to the driver in this mode, to let him be able to take over properly. This study investigates the automation transparency to ensure a meta-cooperation between the driver and the automation and the way to convey information to the driver using Augmented Reality according to some transparency principles. Therefore, among 45 participants, we evaluated five human–machine interface (HMI) in which some or all of the following functions were integrated: information acquisition, information analysis, decision-making and action execution. To validate our transparency principles, we assessed Situation Awareness, discomfort feeling, and the participants' preferences. Even though there is no convergence in the first results, it appears clearly that no transparency in the HMI does not help to understand the environment. Additionally, it appears that “information acquisition” and “action execution” functions are quite necessary. Furthermore, the HMI with the high level of transparency was preferred by the participants. However, more analysis is required to obtain final results.

Keywords Driverless vehicles · Human–machine interface · Cognitive work analysis · Human–machine cooperation · Transparency · Augmented reality · Simulation

✉ Raissa Pokam
raissa.pokam@irt-systemx.fr

Serge Debernard
Serge.Debernard@univ-valenciennes.fr

Christine Chauvin
christine.chauvin@univ-ubs.fr

Sabine Langlois
sabine.langlois@renault.com

¹ IRT SystemX, Centre d'Intégration nano-INNOV, 91120 Palaiseau, France

² Université Polytechnique Hauts-de-France, CNRS, UMR 8201 - LAMIH, F-59313 Valenciennes, France

³ Lab-STICC IHSEV Team, UMR CNRS 6285, Université Bretagne Sud, 56100 Lorient, France

⁴ Renault, Technocentre-Human Factor, 78280 Guyancourt, France

1 Introduction

Nowadays, computers can autonomously carry out tasks that previously could only be performed by human operators. Automation has been defined as “any sensing, detection, information processing, decision-making, or control action that could be performed by humans but is actually performed by machine” (Moray et al. 2000). In the automotive domain, some vehicles can drive themselves on real roads for 140,000 miles with only occasional human intervention and 1000 miles without any human intervention (Markoff, 2010). According to Parasuraman et al. (2000), successful automation is often measured in terms of appropriate operator mental workload, a high degree of Situation Awareness (SA) as well as the absence of complacent behavior and skill degradation. Lee and Seppelt (2009) pointed out three sources of problems related to automation introduction:

- Changes in feedback,
- Changes in tasks and task structure,

- The operators' cognitive and emotional response to changes.

To deal with human factors consequences of automation, they suggest adopting operator-centered automation. This approach of automation incorporates the human in the execution of automated tasks to make sure to provide him/her the most relevant information they need to understand the autonomous systems and efficiently use them (Billings 1997). The operator-centered approach is almost related to the concept of system transparency. Kim and Hinds (2006) argue that transparency is about a user's understanding of why a machine behaves unexpectedly, whereas Lyons (2013) discusses transparency in terms of an operator's perception of the ability, intent and situational constraints of the automation or robot. Then the critical question is "how much and what type of awareness is necessary to promote comprehension in a multi-agent system" (Miller 2014).

Our research took place in a project which aims to design an AR HMI for autonomous driving at the level four of automation according to the Society of Automotive Engineers (SAE) taxonomy. This project is named LRA project (French acronym for Localization and Augmented Reality). The level four of automation level involves four main phases: the manual driving phase and the automated driving phase.

- Phase 1: the manual driving where the human agent is in charge of the vehicle control.
- Phase 2: the transition from manual driving to automated driving where the human agent delegates the vehicle control to the technical agent.
- Phase 3: the automated driving phase where the technical agent controls the vehicle. Consequently, the human agent can carry out some secondary activities. Therefore, the human agent can be driven "out-of-the-loop".
- Phase 4: the transition from automated to manual driving where the human agent should re-engage cognitively and physically in the driving task. This phase, if not completed correctly, can lead to accidents.

Phase 3 constitutes the focus of the work presented in this paper. This phase requires an HMI allowing the driver to monitor the autonomous vehicle if he/she wishes, or even to initiate phase 4 if he/she deems it necessary. This interface must allow the driver to be aware of what is going on outside the car (also known as "Situation Awareness") and what is going on inside the car by understanding what the technical agent can do, what he will do and what it has done. To this end, the right information, in a suitable form, at the right time should be displayed. We identified three questions to orientate the interface design:

1. Which sufficient representation should the driver maintain or establish?
2. How should we design the displays?
3. What is the added-value of Augmented Reality in the displays?

In Sect. 2, the concepts chosen for our study are presented, including the principles of transparency. Twelve principles were then defined within the framework of autonomous driving, and five over them were then evaluated experimentally to define those necessary. Section 3 explains the methodology chosen to test the proposed transparency principles with the definition of five HMI. Section 4 presents the results of the experimental evaluation of these HMIs on the simulator called DrSIHMI and the discussion of what they mean with respect to the transparency principles defined for each HMI. Finally, the main conclusions are presented in Sect. 5.

2 Context and theoretical framework

In this section, three main concepts are examined: human-machine Cooperation and Transparency.

3 Human-machine cooperation

In the context of automation, the human agent and the machine should be aware of what each agent is doing to avoid misunderstandings, misbehavior and later on, mode confusion or inappropriate level of trust. Therefore, it is important that the two (or more) agents in presence should cooperate. Indeed, according to Flemisch et al. (2014), "more than to know what the other is doing, cooperation allows to have a model of the partner in order to know how it's possible to cooperate with it/him/her". Considering the etymology of the word, "Cooperation" is derived from the Latin words "co" (together) and "operation" (work, activity). That means that two agents cooperate if they work together. Biester (2009) has defined cooperation as "a continuous exchange process between driver and automobile, with the exchange process creating a common knowledge base and goals, which in turn ensure a transferability of experiences by means of educability". Therefore, Cooperation supposes that a situation is shared between agents to be commonly aware of the current or future environment or process state Flemisch et al. (2014). The use of the term Cooperation in the context of human-machine systems has already been hinted by Rasmussen (1983) or Hollnagel and Woods (1983). As presented by Hoc (2001), cooperative activities can be differentiated by levels, an action level, a planning level and a meta-level. In their work, Flemisch et al. (2014) have suggested the composition of a maneuver

interface which will provide interaction channels between driver and automation on different levels. Flemisch et al. (2014) identify many attributes for cooperation such as the “traceability and predictability of abilities and intents in both directions (of the machine by the human; of the human by the machine)” and the “dynamic distribution of control/transitions in automation modes”. Bengler et al. (2012) defined a taxonomy of cooperative systems in five layers of cooperation: intention, mode of cooperation, allocation, interface, and contact. Concerning the interface, Bengler et al. (2012) presented that the interface should be multi-modal to increase system’s acceptance, improve the interaction between the agents. More specifically, Flemisch et al. (2016) showed that a Common Work Space which takes the form of a visual, sound and/or haptic interface must provide information from process or environment, agents’ current and future individual and cooperative activities.

In our work, we decided to structure the HMI using the control levels of Michon (1985) to give a brief description of Michon levels:

- The operational level: it is the control level of the vehicle with actuators.
- The tactical level: at this level, drivers exercise maneuver control allowing them to negotiate the directly prevailing circumstances.
- The strategic level: this level defines the general planning stage of a trip, including the determination of trip goals, route, and modal choice, plus an evaluation of the costs and risks involved.

Indeed, we believe that in the LRA project, if there is no cooperation, the single observation by the driver of the technical agent’s behaviors is not sufficient to lead to a proper understanding of what the vehicle is doing. Hence, the HMI must also provide a transparent representation of the different stages of the decision-making process of the machine. Therefore, the “transparency” term is defined in the next section.

4 Transparency

When a human is driving a vehicle, he or she plans for a “desired trajectory which is converted into appropriate commands to be generated by the neural muscular system” (Ungoren and Peng 2005). Therefore, the representation of the dynamic system, also called the “internal model”, is maintained by the human to command the vehicle properly. As Macadam (2003) mentioned, the internal model allows the driver “to compare the time-advanced expectation of the vehicle state at some future time with the directly observed previewed input requirement (path to

follow, desired headway, stopping point, etc.” Macadam (2003) also showed that this expectation “depends upon the driver having some basic understanding of the controlled vehicle dynamics—hence the internal vehicle model concept or its equivalent—in order to perform the projection”. Therefore, in the context of the automation, it clearly appears that an understanding of the behavior of the technical agent is important to ensure a good interaction between the human agent and the technical agent. This understanding is often referred to as “transparency”. Lyons (2013, p.1) explained that “transparency between the robot and the human is one mechanism to facilitate effective interactions between humans and their robotic teammates” in a dynamic environment under some conditions of uncertainty. According to this author, transparency can be divided into two levels:

- The Robot-to-Human transparency: This transparency deals with information that a robotic system needs to convey to a human. Its factors include
 - An intentional model: In this model, Lyons argued that it is important for the user to identify the major functionalities of an autonomous system to fully understand its purpose. He explained that the user should understand “how” the system seeks to perform.
 - A task model: This model includes an understanding of a particular task, information relating to the system’s goals at a given time, information relating to the system’s progress with those goals, information signifying awareness of the system’s capabilities, and awareness of errors.
 - An analytical model: This model communicates the underlying analytical principles used by the system to make decisions. This model allows the human agent to know how the autonomous agent works and the algorithm it will use to deal with a particular situation.
 - An environment model: According to this model, the autonomous system should be capable of communicating to humans an understanding of its environment and the temporal constraints. Through this model, the human agent can know which information the autonomous agent takes into account to make its decisions and verify if that information is appropriately assessed.
- The Robot-of-Human transparency: This transparency deals with information that the system needs to convey awareness and understanding of the human. Its factors include

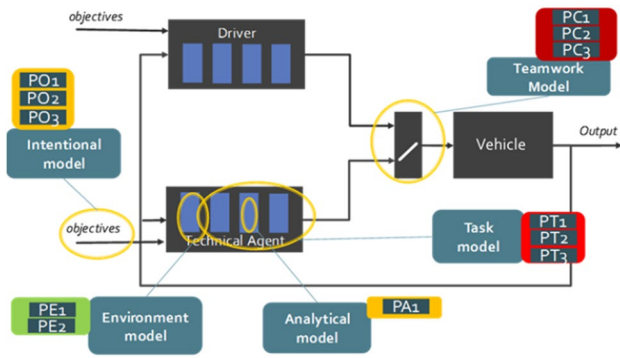

Fig. 1 The 12 principles linked to the Lyons’ model in the context of autonomous driving

- A teamwork model: This model is essential to understand the division of labor for a given task or set of tasks. The teamwork model avoids the decisional conflicts relating to the function allocation between the human agent and the technical agent (Debernard, 1993).
- A Human State model: This model is relating to the communication of an understanding of the humans’ cognitive, emotional, and physical state. Because in the LRA project, we did not have a driver monitoring, we did not use this model.

In this study, from each model, we extract several principles that seem to be relevant to autonomous driving (Fig. 1). Therefore, we define

- Three principles related to the intentional model (POx, Fig. 1). For example, the principle PO1 is “The driver should know the maximum autonomy level of the vehicle as well as the external and internal conditions that allow it to enter the autonomous mode”.
- Three principles related to the task model (PTx, Fig. 1). For example, the principle PT1 is “In the autonomous mode, the driver must be informed that the system will control the vehicle by following accepted driving practices and traffic laws (predictability of the behavior of the vehicle). Furthermore, the driver must be able to detect the actions (e.g., lane change) being performed by the vehicle and understand them” Table 1.

- One principle related to the analytical model (PAx, Fig. 1). It is PA1, “In the autonomous mode, the driver should know how a given maneuver is being carried out or why a particular behavior of the vehicle is observed”.
- Two principles related to the environmental model (PEx, Fig. 1). For example, the principle PE1 is “In the autonomous mode, the driver should have a sufficient understanding of what the autonomous vehicle perceives to realize its analyses and to make its decisions. The driver must be confident that the autonomous vehicle has the right information to make the right decisions and if not, he/she must be able to take control”.
- Three principles related to the teamwork model (PCx, Fig. 1). Among the tree, there is the principle PC1 which is “The driver should know what the current mode is, to avoid any mode confusion”.

These 12 principles enabled us first to select the information that had been determined during the CWA, and second to add information to make the system transparent. In AR, there can be a rather large amount of information to be displayed, which will not necessarily be easily perceived by the driver. Two approaches were used to solve this problem: the levels of Michon as mentioned before and information processing levels. An example of the information processing function/Michon levels classification according to one principle is given in Table 2.

This classification was used to structure the information display in several areas according to the level of activities. Indeed, there are two potential problems:

- The first one concerns the fact that the symbols or icons displayed, which are related to different levels of activity, are not properly understood.
- The second one is that this information can be conveyed simultaneously and, therefore, create an overload of information. The structuration aims to avoid these two problems.

Second, filtering the information was carried out to minimize the number of displayed symbols. The filter takes into account the traffic environment and some operational level

Table 1 Classification of information according to 12 the principles. E.g. for principle PT1 and PE1

	Information acquisition	Information analysis	Decision-making	Action execution
Strategic				
Tactical				
Operational		Lane change of a vehicle in front of the autonomous vehicle		Current autonomous vehicle action (lane change or cruising)

information that can disappear in favor of more important information. An experiment was carried out to test some of these transparency principles.

5 Methods

This section describes the HMI design, the experimental design, and procedure.

5.1 Procedure

To answer the questions asked in the introduction, we used a methodology which is composed of four steps (Pokam Meguia et al. 2015):

- The first step of our methodology is the extraction of information required by the driver. For this purpose, we have decided to apply Cognitive Work Analysis (CWA). CWA helps to precisely determine the driver requirements from which we will derive the interface requirements.
- The step beyond the information requirement definition is the rule-based prioritization through a robust algorithm. In this step, we will also define the information format, its display modality and its output channel by keeping into account Driver–Vehicle–Environment (DVE) conditions and driver state.
- Next, there is the step of interface specification where interaction between the technical agent and the human agent is designed according to the relevant use cases we have chosen.
- The last step consists of users' tests to evaluate our interface and improve the negative aspects. In a simulated environment, we will conduct some tests to refine our previous rules. The final purpose is to assess each of the transparency principles.

5.2 HMI design

Because in our study the vehicle was always in autonomous mode, we focused only on principles 2, 4, 5, 7 and 8 which concern autonomous driving. For each of these five principles, elements related to the information processing functions were defined. Then a brainstorming was carried out to define the visual AR and no-AR grammar of each information. Coupling the four human information processing functions, it was possible to define sixteen HMIs. Regarding experiments, it was made the choice to select only five HMI, the more contrasting ones (Table 2). Indeed, it is possible to write $HMI\ 2 = HMI\ 1 + information\ acquisition + action\ execution$.

Table 2 HMI and the four functions of information processing (“X” means the presence of the elements of the related function; “O” means their presence)

	Information acquisition	Information analysis	Decision-making	Action execution
HMI 1				
HMI 2	X			X
HMI 3	X	X		X
HMI 4	X	X	X	
HMI 5	X	X	X	X

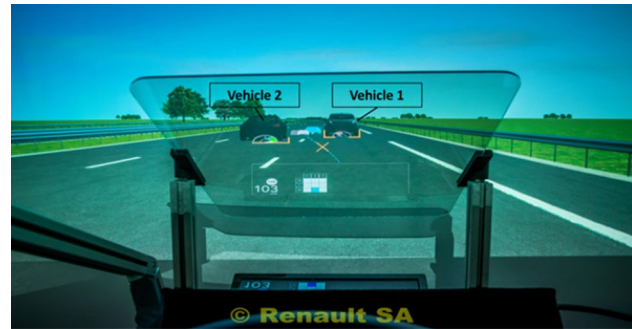

Fig. 2 A screenshot of HMI 5 in the simulator DrSIHMI

A screenshot of this HMI can be observed in Fig. 2. In this figure,

- The EV is driving at 103 km/h in a road section where the speed is limited at 120 km/h.
- The EV is cruising lane with deceleration. This deceleration can be observed by the fact that the blue box in the table with nine boxes is the one at the intersection of the bottom line (line of deceleration) and the middle column (column of lane cruising).
- The vehicle 1 refers to the vehicle in front of the EV in the same lane, which is the target vehicle. It is slower than the EV. This fact is indicated by the red counter of a negative speed differential behind the vehicle 1. Additionally, it is close to the autonomous vehicle. This fact is indicated by the orange icon of high proximity for the target vehicle.
- The vehicle 2 refers to the vehicle in front of the EV in the left adjacent lane. It is slower than the EV. This fact is indicated by the red counter of a negative speed differential behind the vehicle 1. As the vehicle 1, the vehicle 2 is also close to the autonomous vehicle. This fact is indicated by the orange icon of high proximity.

Because of the vehicle 1 speed, the EV had an intent to do lane change, but there is a vehicle with high speed arriving



Fig. 3 DrSIHMI field of view

in the left adjacent lane, the vehicle 3 (not visible in the figure). That is why there is dotted arrow with a red cross to indicate the decision of lane change had been abandoned.

5.3 Experimental design and procedure

In this subsection, we will deal with the participants, the simulator, the driving scenarios and the procedure of the experiment.

5.4 Participants

Forty-five people classified were recruited for the experiment, which was conducted in the DrSIHMI simulator.¹ Each participant was rewarded with a voucher of 50 euros. The average age of the 23 women M_{age}^f was 42.63 with a standard deviation σ^f of 9.23; the average age of men M_{age}^h was 43.41 with a standard deviation σ^h of 9.53.

5.5 Simulator

The study was carried out using DrSIHMI (Fig. 3), a static simulator of the IRT (French acronym for Technology Research Institute) SystemX. This simulator has a realistic surround view.

It includes

- A cockpit with usual car control devices (a steering wheel; an acceleration pedal, a braking one and a clutch one; a gearshift) and a box of buttons. This box allows the participant to express the level of discomfort he/she experiences during a situation.
- Display: The main display is a binocular mirrored HUD divided into two zones—a classical HUD, with a surface of $15 \times 4^\circ$, which presents information without AR representation, and an AR-HUD, with a surface of $15 \times 5^\circ$, which allows the projection of virtual information in the

driving environment for an AR perception type. There was also a remote screen which displays the picture of the route to be followed by the autonomous vehicle as well as the distance between the current point and the ending point. Additionally, three virtual screens allow the rear view and side mirror projections.

- A curve projection screen with an opening angle of 180° . This screen allows the simulation of driving scenarios developed with the simulation software SCANeR, by three high-performance beamers (projectors). The resolution of the images was 1024 pixels in width and 480 pixels in height.

5.6 Driving scenarios

Driving scenarios are defined as the combination of different driving scenes on a given ground. In this test, the ground includes

- A straight line 2×3 lane with a speed limit of 130 km/h;
- A first exit on a road portion with a speed limit of 130 km/h;
- A curve with a speed limit of 120 km/h;
- A highway splitting into 2×2 lanes with a speed limit of 120 km/h;
- A second exit on a road portion with a speed limit of 130 km/h. The route followed by the EV then moved from 2 to 3 lanes with the same speed limit.
- Speed limit road signs at specified locations;
- Exit road signs at the different exits.

The EV was in autonomous mode during the entire experiment, and because the experiment was not aimed to encourage the driver to take over, critical scenes were avoided (Table 3). However, the hazardous scenes were voluntarily characterized by a little high level of danger to provoke some negative interference between what the EV is doing and what the participant would have done.

The position of driving scenes relative to each other helps us to define four driving scenarios:

- The driving scenario 0: It was the shortest driving scenario used in the training phase.
- The driving scenarios 1, 2 and 3 were associated with one of the five HMIs and presented in different order to each participant. They were similar. In other words, these scenarios take place in the same environment, on the same ground.

The driving scenarios were presented to the participants according to a particular procedure.

¹ Driving simulator for human-machine interface studies.

Table 3 Distribution of scenes following the distinction between “normal” and “hazardous” NB: there is no matching or relationship between hazardous scenes and normal ones

List of hazardous scenes	List of normal scenes
[3] Overtaking of a slow truck before the ego vehicle	[1] Starting of the ego vehicle.
[9] Sudden lane change of a vehicle to enter the ego vehicle lane	[2][4][6][8][10][12][14][16][18][20] Cruising
[11] Overtaking with two slow heavy trucks considering the arrival of the police behind;	[5] Overtaking of three vehicles taking an exit
[15] Delayed overtaking because of two vehicles which prevent the ego vehicle to overtake	[7] Turn
	[13] Overtaking of a platoon of four vehicles
	[17] Successive overtaking of three vehicles, one after the other.
	[19] Lane change because of a highway splitting
	[21] Lane change because of a highway exit

5.7 Procedure

Before the test, participants filled out a socio-demographic questionnaire and received instructions containing information about the following driving runs and the highly automated driving system. They were informed that the system would control the vehicle laterally and longitudinally at a set maximum speed and automatically keep the distance to the vehicle ahead. They were also told they would be in established autonomous mode during the whole test so they would not have been asked to take over. It was also stressed that the behavior of the EV in autonomous mode was not homogeneous in each driving scene. Moreover, the HMI elements that they would potentially see were then presented to them. We explained the meaning of each of them. There was not a secondary task, so we told the participants that their task would be to monitor the system according to their information needs as natural as possible. After the presentation phase, it was the training one which lasted around 15 min. This phase aimed to let the participants get used to the simulator, the way the indications were indeed displayed. The participants were installed in DrSIHMI. The different displays were presented. The HMI that was shown to the driver in the training phase included the largest number of

Table 4 Number of participants per HMI

HMI	Number of participants who evaluate the HMI
HMI 1	45
HMI 2	24
HMI 3	22
HMI 4	21
HMI 5	24

possible indications to allow them to see as more as possible HMI elements shown to them in the presentation phase. For example, if the participant had to assess HMIs 1, 2 and 3, HMI 5 was shown to him in the training phase. Each participant has to assess three HMI among the five available. Because HMI 1 was the baseline, it was experimented by all the forty-five people. We try as far as possible to balance the number of participants in the four left HMI (Table 4). Therefore, the groups of participants according to each HMI are not independent.

Each participant’s experiment lasted around 1 h. After each driving run, the participants had to fill out a questionnaire. We collected some data to assess the information function that was important.

5.8 Hypotheses and measurement

In this subsection, we present the hypotheses we defined and the measurement we used to confirm or reverse them.

5.9 Hypotheses

According to the transparency principles, the following hypothesized predictions shall give insight into the research questions.

- Principle 2: The driver must know which tasks the autonomous system is capable of performing, under which conditions it can perform them, and how it will perform them. The driver should know what general functions are allocated to the autonomous system.
- H1: The table with 9 boxes is highly appreciated by the participants.
- H2: The habituation with the driving runs induces a precise knowledge of how the autonomous vehicle works.
- Principle 4: In the autonomous mode, the driver must be informed that the system will control the vehicle by following accepted driving practices and traffic laws (predictability of the behavior of the vehicle). Furthermore, the driver must be able to detect the actions (e.g., lane change) being performed by the vehicle and understand them.

- H3: HMI 5 is preferred to HMI 4 by the participants.
- H4: More than the half of the participants mention the autonomous vehicle speed as mandatory information.
- Principle 5: In the autonomous mode, the driver must be able to perceive the intention of the system (the maneuver it intends carrying out), why, how, and when this maneuver will be carried out.
 - H5: The HMIs 4 and 5, which include the elements of decision analysis, that means the intent of the autonomous vehicle, have a higher score in question 6 which is related to the “projection” level of the Situation Awareness.
 - H6: HMI 5 induces a higher Situation Awareness compared to the other HMI.
- Principle 7: In the autonomous mode, the driver should know how a given maneuver is being carried out or why a particular behavior of the vehicle is observed.
 - H7: HMI 1 induces more discomfort feeling compared to the other HMI prototypes.
 - H8: HMI 3 induces more discomfort feeling compared to the HMI prototype 5.
- Principle 8: In the autonomous mode, the driver should have a sufficient understanding of what the autonomous vehicle perceives to realize its analyses and to make its decisions. The driver must be confident that the autonomous vehicle has the right information to make the right decisions and if not, he/she must be able to take control.
 - H9: HMI 1 induces less understanding of the environment compared to the other HMI.
 - H10: HMI 1 is less preferred compared to other HMI, by the participants.

5.10 Measurement

Considering the hypotheses mentioned above, three types of measures are then defined used to assess each HMI:

- Situation awareness,
- Discomfort feeling,
- Acceptance of HMI.

5.11 Measurement of situation awareness

Endsley (1995) defines Situation Awareness (SA) regarding three levels: “(1) the perception of elements in the environment within a volume of time and space, (2) the

comprehension of their meaning, and (3) the projection of their status in the near future”. Practically, it is still a challenge to appropriately measure it (Endsley and Garland 2000). Among the tools developed to measure SA, there is the Situation Awareness Global Assessment Technique (SAGAT) which is a global one. It has been used to assess automation concept. Indeed, it has been noted that operators who monitor automated systems may become “out-of-the-loop” and, therefore, less able to take over manual control when needed (Endsley and Kaber 1999).

In our study, measuring SA will provide insight into the quality and effectiveness of the offered HMI. The SAGAT queries were orally asked during the first driving run and not repeated to avoid a learning effect. These queries addressed all three levels of SA (Table 5). Because of their hazardous character, driving scenes 9 and 11 (Table 3) were selected as scenes where freezes will occur. We alternate these scenes from one participant to another. For example, we stop the simulation in scene 9 for participant 1, we stop the simulation in scene 11 for participant 2, we stop the simulation in scene 9 for participant 3, we stop the simulation in scene 11 for participant 4, etc.

Therefore, 45 protocols were gathered according to the following distribution: 15 SAGAT answers for HMI 1, 9 for HMI 2, 8 for HMI 3, 6 for HMI 4 and 7 for HMI 5. Participant responses to the SAGAT probes were scored either as 1 (correct) or 0 (incorrect). We considered that the number of wrong answers reflected the participant’s lack of SA.

Table 5 Questions asked about the three Situation Awareness levels

Level of SA	Questions
Level 1	1. What is the vehicle actually doing? <ul style="list-style-type: none"> a. Cruising b. Lane changing to the left c. Lane changing to the right 2. Concerning the speed, what is the dynamics of the vehicle? <ul style="list-style-type: none"> a. It is accelerating b. It is decelerating c. It has a constant speed 3. How many vehicles are in front of your vehicle? 4. How many vehicles are behind your vehicle?
Level 2	5. Is the vehicle speed below the speed limit? <ul style="list-style-type: none"> a. Yes b. No
Level 3	6. What is the next action of your vehicle? <ul style="list-style-type: none"> a. Cruise b. Lane change to the left c. Lane change to the right

5.12 Measurement of discomfort feeling

When the participants consider that a situation is uncomfortable, they have to push the button 1 which becomes red at the first push. They can press this button many times, as long as the uncomfortable feeling increases. When the uncomfortable feeling disappears, the participants have to push the button 2 which became green. A single push on the button 2 is necessary. The other buttons are not used. The number of times that the button 1 is pushed per trial gives an indication of the number of times the discomfort feeling occurred. The delay between the first push of button 1 and the push of button 2 is an indication of how long the discomfort feeling lasts.

5.13 Measurement of HMI acceptance

In this research, questionnaires were used to gather personal data such as age, gender, experience with ADAS, and driving mileage per year. They were also used to collect test person feedback regarding interface design properties. Indeed, after each driving run, each participant was required to assess the HMI that had been shown to him. Ten questions concerning trust, intuitiveness, and adequacy of information to the situation were asked. The type of scale used for the queries answers is the Linear Analog Visual Scale. It consists of a value scale made of a line of 10 cm, indicating at both ends of the line, the opposing views (Retel-Rude and Retel 2000). This type of scale had been used, for example, by Muir and Moray (1996) in their experiment for analyzing trust in automatic control, and by Rajaonah et al. (2006) in a research on Human trust in Adaptive Cruise Control (ACC). Indeed, for each of the question, the participants were requested to put a cross on a line which was defined between two extremities. One extremity corresponds to an extreme point of view (for example, very positive), and the other one corresponds to the opposite point of view (in this case, very negative). To avoid “systematic” answers, the valence of the answers was inverted for some questions. For the open-ended questions, the participant should indicate the HMI elements that were missing. An example of the item we used is presented in Fig. 4. Results were then digitized and subjected to analysis.

A closing question was asked to each participant at the end of the three driving runs to know which one of the three HMI helped him to understand better what is going on. The

Following my drive on the simulator, I believe I know how the Human Machine Interface works.

Not at all Absolutely

Fig. 4 An item example associated with the Linear Analog Visual Scale

purpose of the question was to know the participant preference among the HMI. It was formulated as follows: “Among the three HMI, which one helps you to understand better how the ego vehicle works?” It was important to stress that it was not the comfort in the simulator we want to assess to avoid that the order of preference to be inversely related to the order of the presentation of HMI in the test.

6 Results and discussion

The previous section described the method we used to test the HMI on the following dimensions: (1) Situation Awareness, (2) Discomfort Feeling and (3) HMI acceptance. This section reports the results of this test according to three aspects: Situation Awareness, Discomfort Level, and HMI acceptance.

6.1 Situation awareness assessment

As described in the previous section, each participant was submitted to a freeze situation in their first run. This results in 45 SAGAT questionnaires. We formulated some hypotheses in connection with the research questions. Our findings demonstrate that there was no effect of the driving run on the SAGAT score. Generally, the score was very low in SA level three, regarding question six. It was also very low in question four which concerns the number of vehicles behind the EV. One explanation is that almost all the participants focused their attention on what was going on in front of them. During exchanges, some of them explicitly mentioned that they would have preferred to have e-mirrors in their immediate field of view near the HUD to not take their eyes off the road. We conducted six Chi-square tests with a confidence level of 95%. We gathered our results in a radar figure (Fig. 5) which is a graphical method of displaying multivariate data in the form of a two-dimensional chart of three or more quantitative variables represented on axes starting from the same point. In our study, each axis represents one of the six questions. For each question, the score associated with an HMI is indicated. Then the different scores for each HMI are linked to form a figure.

Our result shown was that there was a significant relationship between the scores in question two and the HMI ($p < 0.05$). We found out that $nca(HMI 5) > nca(HMI 4)$, where nca refers to “number of correct answers”. It is imaginable that because HMI 5 included the elements of action execution (contrary to HMI 4), it has contributed to a better perception of autonomous vehicle action. Moreover, there was also a significant relationship between answers in question four and the HMI (p). We particularly found out that $nca(HMI 2) > nca(HMI 1)$. This observation reveals that “other vehicle detection” helps to have a better perception of the

Fig. 5 Number of correct answers per HMI and per question

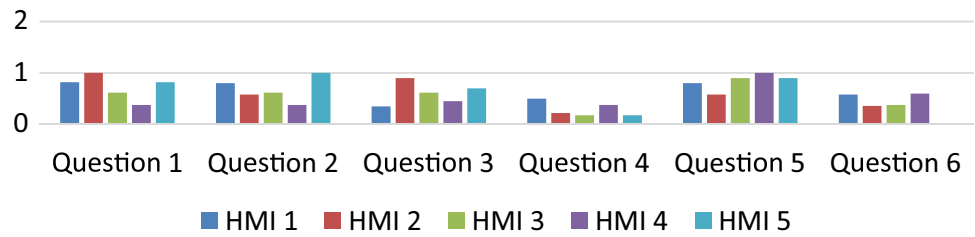

number of vehicles ahead of the EV. Indeed, HMI 2 includes elements of other vehicle detection, contrary to HMI 1.

Descriptively speaking, in question six, we found out that $nca(HMI\ 1) > nca(HMI\ 4) > nca(HMI\ 3) > nca(HMI\ 2) > nca(HMI\ 5)$. This result, even if it is not significant, tends to reverse H5. Contrary to what was expected, the HMIs 4 and 5 did not have the best scores in question 6. However, HMI 4 had the second-best score. One possible explanation to the fact that HMI 5 had the worst score is that, because of the table with 9 boxes, most participants were cognitively captured by the table to the detriment of other information interfaces.

An overall SAGAT score per HMI was calculated by summing the scores from questions 1–6 for each in this HMI. The results were not significant. The mean SAGAT score was 3.48. The highest SAGAT mean score was achieved in HMI 1, which scored 3.73. The lowest SAGAT mean score was achieved in HMI 4, which scored 2.25. This result tends to reverse hypothesis H6. One possible explanation is that without information, the participant tended to be more attentive of what was going around using the manual driving routine. However, HMI 4 is not very far away; it ranked itself with the second-best score. It seems that more analysis should be performed. However, it is quite surprising that between HMIs 4 and 5, there was such a gap, even though elements of the “action execution” function are the only differential between them (included in the former and not in the latter). This can be explained by the fact that, according to some participants, HMI 5 contained complex information like the table with nine boxes. This table has potentially captured the participants’ attention.

6.2 Discomfort feeling assessment

The discomfort feeling was assessed through the number of pushes on the discomfort button, the button one. By exploring the results, it appeared that just around 5% of the participants pushed the green button (button two, which notifies that the discomfort feeling is finished) after pushing the red one (button one). So, we did not consider the number of pushes on the button two in the following.

There was no effect of the driving number on the number of pushes on button one. In average, the number of pushes on button one was highest in HMI 1 ($np(HMI\ 1) = 3.5$), and

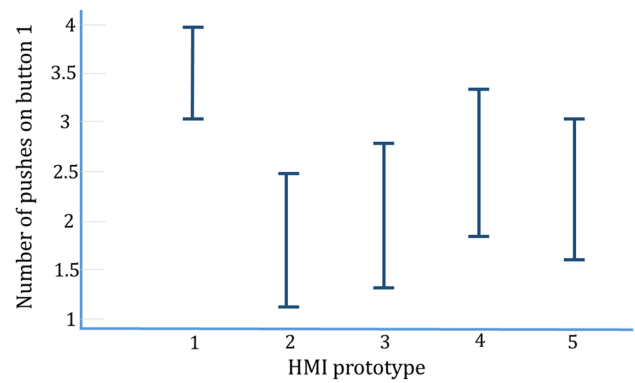

Fig. 6 Mean number of pushes on the button 1 in each HMI

the number was lowest in HMI 2 ($np(HMI\ 2) = 1.8$) (Fig. 6). These results tend to confirm hypothesis H7. Indeed, it seems that without any information, the participants did not feel comfortable with the autonomous vehicle, particularly in the scene of lane changing with two trucks.

Moreover, by applying the Least Square Difference of Fisher, it appears that there was a significant difference in mean number pushes on button one between HMIs 1 and 2 ($d = 1.74$) (Table 6). There is also a significant difference in the mean number of pushes on button 1 between HMIs 1 and 3 ($d = 1.44$). A reason for this could be that elements

Table 6 Pair comparison for number of pushes on button 1 (method: 95.0% LSD)

Contrast between HMIs	Significance	Difference	\pm Limit
1–2	*	1,7419	1,1767
1–3	*	1,44,734	1,22,166
1–4		0,918,675	1,24,637
1–5		1,17,655	1,19,809
2–3		–0,294,563	1,44,927
2–4		–0,823,228	1,47,894
2–5		–0,56,535	1,46,048
3–4		–0,528,664	1,54,914
3–5		–0,270,786	1,47,588
4–5		0,257,878	1,49,062

*Statistical difference

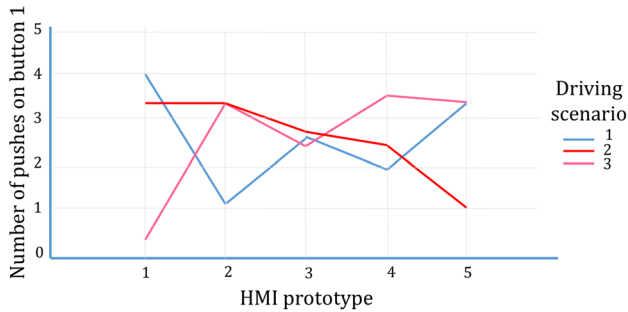

Fig. 7 Mean number of pushes on button in each HMI according to each driving scenario

of information acquisition, information analysis, and action functions are essential in an HMI to let the participant feel comfortable with the driving. Descriptively speaking, HMI 3 induced fewer number pushes than HMI 5. This result tends to reverse in the first place hypothesis H8. One possible explanation is that HMI 5 includes “too much” information according to many participants. We presume that this feeling concerning HMI 5 is also because of the table with nine boxes.

Furthermore, there was a significant effect of the crossed factor HMI *Driving scenario (Fig. 7). Particularly, the button one had been mostly pushed in scenario one with HMI 1. The button one was least pushed in scenario three with HMI 1. Roughly, it can be written that HMI 1 (scenario 1) > HMI 4 (scenario 3) > HMI 1 (scenario 2) > HMI 5 (scenario 3) > HMI 2 (scenario 3) > HMI 2 (scenario 2) > HMI 5 (scenario 1) > HMI 3 (scenario 2) > HMI 3 (scenario 1) > HMI 3 (scenario 3) > HMI 4 (scenario 2) > HMI 2 (scenario 1) > HMI 5 (scenario 2) > HMI 1 (scenario 3). It is hard to explain this impact of the “Scenario driving” factor because all the scenarios included the same driving scenes on the same ground. It can also be observed that for HMI prototype 3, there are few differences in the number of pushes on button according to driving scenarios. However, for HMI prototypes 1, 2 and 5, there are some differences among driving scenarios, on the other hand. As in the case before, this phenomenon can hardly be explained because the scenarios were similar.

6.3 HMI acceptance assessment

As we mentioned before, after each driving run, the participant had to fulfill a questionnaire concerning the HMI he/she saw. The following hypothesized predictions shall give insight into the research questions.

We analyzed all of these questionnaires using a general linear model. There were some significant results.

First, there was a significant effect of the driving number ($p_{Dn} = 0.00185$; $p_{Dn} < 0.05$, where D_n refers to “Driving number”):

- The participants better understood how an HMI works in the second driving than in the first one.
- The participants better understood how an HMI works in the third driving than in the first one in the third driving.

This first result confirms the hypothesis H2. Indeed, with the driving runs, the participant better understands the way the autonomous vehicle works. One participant clearly stated it, saying at the third run, “*This run was good. Now, I know how the autonomous vehicle works compared to the first run*”.

Second, there was a significant effect of the HMI type on the autonomous vehicle understanding ($p_{HMI} = 0.0071$; $p_{HMI} < 0.05$):

- HMI 2 allowed a better understanding of the autonomous vehicle than HMI 1.
- HMI 4 allowed a better understanding of the autonomous vehicle than HMI 1.
- HMI 5 allowed a better understanding of the autonomous vehicle than HMI 1.

This second outcome confirms hypothesis H9. Indeed, with the transparency, an HMI offers a better understanding of the outside environment.

On the one hand, only 5% of the participants mentioned the table with nine boxes as a useful element. This tends to reverse hypothesis H1. Indeed, they would have like that this table presents the action intention of the autonomous vehicle instead of making partially redundant the action information in Augmented Reality. We think that most of them did not understand why this table has been integrated into the classical HUD. Maybe, more precision in the presentation phase is necessary to make them understand that the table was not there to duplicate some information but to give a whole picture of all possible actions of the autonomous vehicle. On the other hand, almost all the participants mentioned the autonomous vehicle and the speed limit as perceived and useful information. This outcome tends to confirm hypothesis H4. Therefore, it appears clearly that these two pieces of information are the strict minimum information for the autonomous vehicle interface in established autonomous mode.

Concerning the closure question, we would like to reiterate that each participant made three driving scenarios assessing each time the HMI they used. At the end of the test (that means, after seeing the three HMI), each participant had to rank the HMI relating the way they reflect the vehicle’s behavior. After our analysis, there were two main outcomes

Fig. 8 HMI ranking

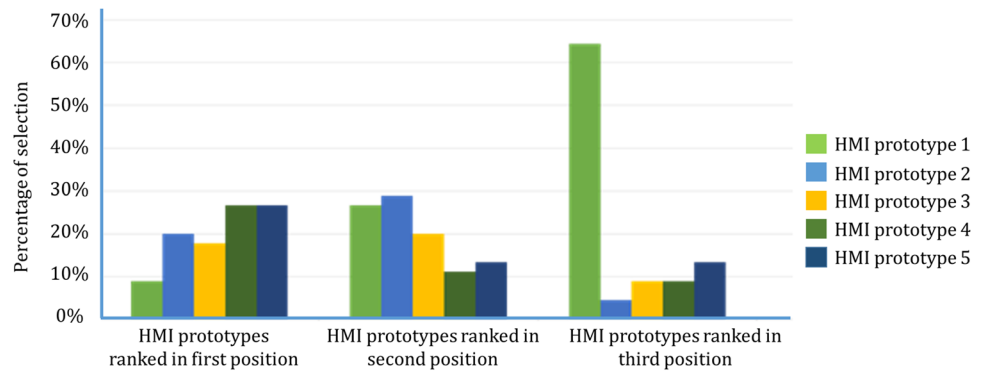

(Fig. 8). First, HMI 1 was mainly significantly in the third position by just over 60% of the participants ($p < 0.05$). This outcome confirms hypothesis H10. Indeed, the fact that HMI 1 which is the HMI reference is ranked as the lowest among the HMI in the third position, lower than HMI 2, suggests that at least, information acquisition function is essential in transparency. This result also supports a study of Sinha and Swearingen (2002) which revealed that people usually prefer the HMI perceived as transparent.

Second, on average, HMIs 4 and 5 were mainly ranked first by just over 25%. Even if this result is not significant ($p > 0.05$), it tends to reverse hypothesis H3. Indeed, contrary to what was expected, HMIs 4 and 5 had the same position. However, this result suggests that the higher levels of transparency are preferred by the participants. Further analysis is required to conclude.

7 Conclusion

In this study, we investigated the impact of five HMIs with different transparency levels in the established autonomous mode. The HMI was defined according to the information processing functions: information acquisition, information analysis, decision-making and action execution. To assess

the appropriate content of the necessary HMI, an experiment with 45 participants was conducted in the DrSIHMI simulator of SystemX. Each participant “drove” three times with a different HMI. The reference HMI was displayed for all the participants. The driving scenario included normal and hazardous scenes like a sudden lane change of the autonomous vehicle because of particular context conditions. The driving scenario was divided into three main road sections: straight road, curved road, road split and road exit. We defined ten hypotheses related to each principle. We then evaluated them using Situation Awareness assessment, discomfort feeling assessment, and HMI acceptance assessment. The results are mainly gathered in Table 7.

The first results do not allow to validate all the principles. However, we can say that

- Principle 5 (In the autonomous mode, the driver must be able to perceive the intention of the system (the maneuver it intends carrying out), why, how, and when this maneuver will be carried out.) tends to be reversed.
- Principle 8 (In the autonomous mode, the driver should have a sufficient understanding of what the autonomous vehicle perceives to realize its analyses and to make its decisions. The driver must be confident that the autonomous vehicle has the right information to make the right

Table 7 First result summary (“O” refers to the correct proposition column)

Principles	Hypotheses	Confirmed	Rejected	Trend to confirmation	Trend to reversal
Principle 2	H1	–	O	–	–
	H2	O	–	–	–
Principle 4	H3	–	–	–	O
	H4	O	–	–	–
Principle 5	H5	–	–	–	O
	H6	–	–	–	O
Principle 7	H7	–	–	O	–
	H8	–	–	–	O
Principle 8	H9	O	–	–	–
	H10	O	–	–	–

decisions and if not, he/she must be able to take control.) is confirmed.

- The results are mitigated for Principles 2, 4 and 7.
- It is almost sure that the “no transparency” HMI is not a good option because of the discomfort feeling it induces.
- By considering the information processing functions, the “information acquisition” and the “action execution” functions seem to be essential. Therefore, if a level of transparency has to be defined to ensure a good interaction between the technical agent and the human one, this level consists of showing to the human agent what the technical agent sees and what it is doing.
- Considering Situation Awareness and discomfort feeling, HMI 4 and HMI 5 were not well positioned. However, they were highly ranked in the first position by the participants. This result is not new. Indeed, Naranjo et al. (2010) demonstrated that the need of information is higher for participant considering the User Experience (HMI acceptance) comparatively to the need considering the cognitive activities (Situation Awareness and discomfort feeling).

Other studies have to be conducted to confirm these results. While the current work does provide an advance in our understanding of HMI transparency on Situation Awareness, clear limitations exist. First, the experiment was carried out in a simulator where the ecological validity has already been addressed. Therefore, the current findings need to be examined on an open road. Second, the gathered data were mainly qualitative. Future work should continue to examine how the HMI transparency principles affect the Situation Awareness by analyzing more objective measures like eye tracking. Indeed, the use of eye-tracking equipment can provide useful information on visual monitoring behavior to find out, for instance, on which parts of the vehicle interface visual attention is allocated. In this study, we have recorded each participant’s mirror glancing behavior with an SMI eye tracker. Therefore, these records have to be precisely analyzed to form a non-biased picture of the transparency principles impact. Furthermore, future studies could use a secondary task, like a real conversation, to compare the results to this study. Additionally, one would possibly want to explore the content of the HMI in take-over phase, with future evaluations.

Acknowledgements This work receives support from the French government in accordance with the PIA (French acronym for Program of Future Investments) within the IRT (French acronym for Technology Research Institute) SystemX.

References

- Bengler K, Zimmermann M, Bortot D, Kienle M, Damböck D (2012) Interaction principles for cooperative human-machine systems. *Inform Technol Methoden und Innovative Anwendungen der Informatik und Informationstechnik* 54(4):157–164
- Biester L (2009) Cooperative automation in automobiles. Dissertation Humboldt-University Berlin zu Berlin, Mathematisch-Naturwissenschaftliche Fakultät I
- Billings CE (1997) Aviation automation: the search for a human-centered approach. Lawrence Erlbaum Associates Publishers, Mahwah, NJ
- Debernard S (1993) Contribution à la répartition dynamique de tâches entre opérateur et système automatisé: application au contrôle du trafic aérien (Doctoral dissertation)
- Endsley MR (1995) Toward a theory of situation awareness in dynamic systems. *Human Factors* 37(1):32–64
- Endsley MR, Garland DJ (2000) Theoretical underpinnings of situation awareness: a critical review. *Situation awareness analysis and measurement* 1:3–32
- Endsley MR, Kaber DB (1999) Level of automation effects on performance, situation awareness and workload in a dynamic control task. *Ergonomics* 42(3):462–492
- Flemisch FO, Bengler K, Bubb H, Winner H, Bruder R (2014) Towards cooperative guidance and control of highly automated vehicles: h-mode and conduct-by-wire. *Ergonomics* 57(3):343–360
- Flemisch F, Abbink D, Itoh M, Pacaux-Lemoine M-P, Wessel G (2016) Shared control is the sharp end of cooperation: towards a common framework of joint action, shared control and human machine cooperation. In: IFAC analysis, design and evaluation of human-machine systems, Kyoto, Japan
- Hoc J-M (2001) Towards a cognitive approach to human-machine cooperation in dynamic situations. *Int J Human Comput Stud* 54:509–540
- Hollnagel E, Woods DD (1983) Cognitive systems engineering: New wine in new bottles. *Int J Man Mach Stud* 18(6):583–600
- Kim T, Hinds P (2006). Who should I blame? Effects of autonomy and transparency on attributions in human-robot interaction. In: Robot and human interactive communication, 2006. ROMAN 2006. The 15th IEEE international symposium on (pp 80–85). IEEE
- Lee JD, Seppelt BD (2009) Human factors in automation design. In: Springer handbook of automation. Springer, Berlin, Heidelberg, pp 417–436
- Lyons JB (2013) Being transparent about transparency: a model for human-robot interaction. In: AAAI spring symposium series: trust and autonomous systems
- Macadam CC (2003) Understanding and modeling the human driver. *Vehicle Syst Dyn* 40(1–3):101–134
- Markoff J (2010) Google cars drive themselves, in traffic. *The New York Times* 10(A1):9
- Michon JA (1985) A critical view of driver behavior models: what do we know, what should we do? In human behavior and traffic safety. Springer, Boston, pp 485–524
- Miller CA (2014) Delegation and transparency: coordinating interactions so information exchange is no surprise. In: International conference on virtual, augmented and mixed reality, Springer International Publishing, pp 191–202
- Moray N, Inagaki T, Itoh M (2000) Adaptive automation, trust, and self-confidence in fault management of time-critical tasks. *J Exp Psychol* 6(1):44
- Muir BM, Moray N (1996) Trust in automation. Part II. Experimental studies of trust and human intervention in a process control simulation. *Ergonomics* 39:429–460
- Naranjo JE, Jiménez F, García Fernández F, Armingol Moreno JM, Zato JG, Quero A (2010) Specification and development of a HMI for ADAS, based in usability and accessibility principles
- Parasuraman R, Sheridan TB, Wickens CD (2000) A model of types and levels of human interaction with automation. *IEEE Trans Syst Man Cybern* 30:286–297

- Pokam Meguia R, Chauvin C, Debernard S, Langlois S (2015) Towards autonomous driving: an augmented reality interface for lane change. In: 3rd international symposium on future active safety technology toward zero traffic accidents—FAST-zero'2015, Gothenburg, Sweden
- Rajaonah B, Anceaux F, Vienne F (2006) Trust and the use of adaptive cruise control: a study of a cut-in situation. *Cogn Technol Work* 8(2):146–155
- Rasmussen J (1983) Skills, rules, and knowledge; signals, signs, and symbols, and other distinctions in human performance models. *IEEE Trans Syst Man Cybern* 3:257–266
- Retel-Rude N, Retel O (2000) *Statistique en psychologie*. In Press éd
- Sinha R, Swearingen K (2002) The role of transparency in recommender systems. In: CHI'02 extended abstracts on Human factors in computing systems. ACM, pp 830–831
- Ungoren AY, Peng H (2005) An adaptive lateral preview driver model. *Vehicle Syst Dyn* 43(4):245–259