



**HAL**  
open science

## Multiwavelength high-repetition rate source

Ugo Andral, Christophe Finot

► **To cite this version:**

Ugo Andral, Christophe Finot. Multiwavelength high-repetition rate source. *Laser Physics*, 2020, 30, pp.016203. 10.1088/1555-6611/ab5588 . hal-02282843

**HAL Id: hal-02282843**

**<https://hal.science/hal-02282843v1>**

Submitted on 10 Sep 2019

**HAL** is a multi-disciplinary open access archive for the deposit and dissemination of scientific research documents, whether they are published or not. The documents may come from teaching and research institutions in France or abroad, or from public or private research centers.

L'archive ouverte pluridisciplinaire **HAL**, est destinée au dépôt et à la diffusion de documents scientifiques de niveau recherche, publiés ou non, émanant des établissements d'enseignement et de recherche français ou étrangers, des laboratoires publics ou privés.

# Multiwavelength high-repetition rate source

**Ugo Andral and Christophe Finot \***

Laboratoire Interdisciplinaire CARNOT de Bourgogne,  
UMR 6303 CNRS-Université de Bourgogne-Franche-Comté,  
9 Av. A. Savary, BP 47 870, 21078 DIJON Cedex, FRANCE

\* christophe.finot@u-bourgogne.fr

## ***Abstract***

We propose and experimentally validate an all-optical approach to generate simultaneously several pulse trains with identical temporal and spectral properties. Applying a temporal sinusoidal phase modulation followed by a shaping of the spectral phase enables us to handle several channels. The principle of operation is experimentally demonstrated at repetition rates of 14 and 40 GHz with up to four channels.

***Keywords:*** optical pulse train generation, multiwavelength source.

## **1. Introduction**

The generation of high-quality pulse trains at repetition rates of several tens of GHz remains a crucial step for optical telecommunications, optical sampling or component testing applications. Unfortunately, the current bandwidth limitations of optoelectronic devices do not allow the direct generation of well-defined optical pulse trains with low duty cycles. Actively mode-locked fiber lasers were found to be an efficient way to overcome this limitation <sup>1</sup> but they remain an onerous and complex option. As an alternative approach, several cavity-free operation techniques have been suggested taking advantage of the progressive nonlinear reshaping experienced in optical fibers as the result of the distributed interaction of dispersion and Kerr nonlinearity <sup>2-4</sup>. An alternative set of linear solutions is based on a direct modulation of the temporal phase that is then converted into an intensity modulation through a dispersive element imprinting a spectral quadratic phase <sup>5-7</sup>. Picosecond pulses at repetition rates of several tens of GHz have been successfully demonstrated but the resulting pulse train remains impaired by a limited extinction ratio or by the presence of detrimental temporal sidelobes <sup>5-7</sup>. We have recently proposed to involve a triangular spectral phase profile <sup>8</sup> instead of a quadratic phase. Significant improvement of the temporal profile is then observed, and close-to-Gaussian Fourier-transform limited pulses are experimentally demonstrated with a duty cycle below 1/4 and a remarkable stability.

In this contribution, we experimentally demonstrate that this versatile architecture can be easily extended to process multiple optical carriers simultaneously. Whereas handling several wavelengths is extremely complex in nonlinear approaches due to cross-phase modulation, our linear method,

similarly to previously demonstrated time-lens schemes <sup>9</sup>, should not be affected by any crosstalk between the different channels. Moreover, similar pulse quality is expected for each wavelength. We first introduce the principle of our approach and the experimental setup we implement. Experimental validation is then presented and discussed for repetition rates of 14 GHz and 40 GHz and for two or four channels.

## **2. Principle of operation and experimental setup**

Our method is based on the principle detailed in <sup>8</sup>. A continuous optical wave with an amplitude  $\psi_0$  and a carrier frequency  $f_c$  is temporally phase-modulated by a sinusoidal waveform with  $A_m$  being the amplitude of the phase modulation and  $f_m$  its frequency. The temporal sinusoidal phase leads to a set of spectral lines that are equally spaced by  $f_m$  and which amplitude can be expressed using a Jacobi-Anger expansion <sup>10</sup>. A phase shift of  $\pi/2$  between each spectral component exists and can be described by a triangular spectral phase profile. Applying a quadratic spectral phase (i.e. a dispersive element) can therefore only partly compensate for this initial phase, leading to the emergence of temporally localized pulse structures with a period  $T_0 = 1 / f_m$  impaired by a deleterious residual background and by a poor extinction ratio. With the progress of linear shaping such as programmable liquid-crystal modulators <sup>7,11</sup>, it becomes feasible to imprint an exact triangular spectral phase profile resulting in a flat spectral phase. As a consequence, the temporal pulse shape obtained is a Fourier-transform limited waveform and it has been shown that for an

optimum value  $A_m = 1.1$  rad, a close-to-Gaussian profile is achieved, with an excellent extinction ratio.

As this described approach does not involve any nonlinear effects, it can sustain multiple wavelengths. The experimental setup we implement to validate the multi-channel operation is sketched in Fig. 1 and is based on devices that are commercially available and typical of the telecommunication industry. An array of up to four continuous wave lasers with wavelengths spaced by 200 GHz or 400 GHz (ranging from 1545.7 nm up to  $\lambda = 1551$  nm or from  $\lambda = 1541.5$  nm up to  $\lambda = 1551$  nm, respectively) are wavelength multiplexed using a 200-GHz WDM multiplexers. Polarization controllers are inserted to ensure that all the channels have the same linear polarization at the input of the Lithium Niobate phase modulator driven by an amplified sinusoidal electrical signal with  $f_m = 14$  GHz or 40 GHz. A linear spectral shaper (Finisar Waveshaper) based on liquid crystal on silicon technology <sup>11</sup> is then used to apply the suitable triangular spectral phase on each channel. By taking into account an additional linear spectral phase, the component can also be used to control accurately the delay of each channel. Moreover, the equipment can also accommodate the various power levels delivered by the continuous wave lasers. The resulting signal is characterized with a high-resolution optical spectrum analyzer (5 MHz of resolution). The temporal aspects are monitored by means of a high-speed optical sampling oscilloscope (1 ps resolution) or by means of an electrical sampling oscilloscope (50 GHz bandwidth) connected to a high-speed photodiode (50 GHz bandwidth) and synchronized with the clock. The records may be obtained after wavelength demultiplexing using a dedicated component or using directly the wavelength routing ability of the spectral shaper.

### **3. Experimental results**

In order to test our setup, we have first generated a single pulse train at a wavelength of 1551 nm and a repetition rate  $f_m$  of 14 GHz. Results obtained for a phase modulation depth  $A_m$  of 1.1 rad are reported on Fig. 2(a) (blue line). The initial phase modulation is converted into a pure intensity modulation leading to a train of well-separated ultrashort pulses at the repetition rate  $f_m$ . The resulting pulse train is characterized by an excellent extinction ratio (>20 dB), well beyond the performance that can be reached with a usual group delay dispersion circuits imprinting a quadratic spectral phase. The pulse waveform can be adjusted by a Gaussian shape (blue circles) with a full-width at half maximum duration of 17 ps (duty cycle of 4.2). The signal resulting from the insertion of a second optical carrier (at a wavelength of 1549 nm) leads to the results plotted with a purple line. The delay between the two pulse trains is tuned by applying an additional linear spectral phase on the spectrum of the second channel. We can first note that the presence of a second wavelength does not affect the temporal properties of the initial pulse train. Then, given the duty cycle of the pulse trains and the good extinction ratio, the two pulse trains can be time interleaved to produce a pulse train with a repetition of 28 GHz where two consecutive pulses have different central frequencies.

Results of the extension up to 4 channels are presented in panels (b) and (c) of Fig. 2. Regarding the spectral aspects, we do not observe any sign of crosstalk between the different channels. Each pulse train exhibit a similar spectral waveform that can be fitted by a Gaussian shape with a fwhm width of

28 GHz. With a time-bandwidth product of 0.48, all our pulse trains are extremely close to the theoretical value of Gaussian Fourier-transform limited waveforms (0.44). Temporal results summarized on Fig. 1(c) confirm the absence of interferences between the various channels that are not affected by the presence of neighboring channels. Once again, the delay between the different channels can be precisely tuned using the spectral phase shaping abilities of the programmable linear shaper.

We finally present in Fig. 3 the results achieved at a repetition rate of 40 GHz for four channels spaced by 400 GHz. The conclusions previously drawn at 14 GHz can be extended to this repetition rate. Once again, the spectra are of high quality as assessed by their high level of symmetry and the high optical signal-to-noise ratio (above 65 dB, measured with a resolution of 5 MHz). They present identical properties and can be adjusted by a Gaussian waveform with a fwhm width of 68 GHz. Regarding the temporal aspect, high-quality pulses are recorded after wavelength demultiplexing on the optical sampling oscilloscope. All four channels present similar quality with a Gaussian profile and a fwhm duration of 6.7 ps combined with an excellent extinction ratio. Note that compared to the generation at 14 GHz, the duty-cycle is restricted to 3.7 due to the modulation depth  $A_m$  limited to 1 rad by the optoelectronic bandwidth of our temporal phase modulation stage. Once again, a time-bandwidth product of 0.46 indicates the Fourier-transform limited nature of the generation.

## **4. Conclusions**

In order to conclude, we have extended the approach initially proposed in <sup>8</sup> and we have demonstrated the simultaneous processing of several optical carriers. As our technics is strictly linear, no sign of crosstalk between the various channels has been observed. Experimental results involving a rather simple setup demonstrate the generation of four wavelength multiplexed pulse trains with identical pulse quality. A higher number of channels can be encompassed and the proof-of-principle experiment carried out at telecommunication wavelengths of the C-band can be straightforwardly transferred into other spectral regions. Repetition rates of 14 GHz and 40 GHz have been successfully tested and close to Fourier-transform limited Gaussian pulses have been recorded with an excellent extinction ratio, which could be of interest in a variety of applications ranging from high-speed real-time sampling to optoelectronic testing, WDM parallel processing, optical code division multiple-access applications, or spectroscopy. As the delay between the different channels could be accurately tuned, the pulse trains can be time-interleaved or synchronized, resulting in a higher peak power. It also opens possibilities of intensity shaping similar to the one demonstrated using the temporal Lau effect <sup>12</sup>. Contrary to nonlinear approaches based on the self-phase modulation induced spectral broadening <sup>13</sup> or on high Q-factor resonators <sup>14</sup>, our technics does not require ultrashort input pulses, a flattened continuum or a CW with a finely controlled central wavelength. Note that with our approach, the resulting pulse trains are not mutually coherent. Finally, as the principle of operation is purely linear, no Erbium doped fiber amplifier is required, thus limiting the source of detrimental noise. The versatile reshaping process is here quite



energy efficient, since the optical losses are restricted to the insertion losses of the phase modulator and of the spectral shaper.

***Acknowledgements:***

We acknowledge the support of the Institut Universitaire de France (IUF), the Bourgogne-Franche Comté Region, the French Investissements d'Avenir program and the Agence Nationale de la Recherche (ANR-11-LABX-01-01). We thank Julien Fatome and Bertrand Kibler for fruitful discussions. The article has benefited from the PICASSO experimental platform of the University of Burgundy.

## Figure captions:

Fig. 1 Experimental setup. CW: Continuous Wave; PM: Phase Modulator; ESO: Electrical Sampling Oscilloscope; OSO: Optical Sampling Oscilloscope; HR OSA: High Resolution Optical Spectrum Analyzer.

Fig. 2 Experimental results obtained for a repetition rate of 14 GHz with channels spaced by 200 GHz. (a) Temporal intensity profile of a single channel (1551 nm) and two channels (1551 and 1549 nm) temporally interleaved and simultaneously recorded on a photodiode (blue and purple lines respectively). The blue circles represent a fit by a Gaussian waveform. (b) Optical spectrum for four channels configurations. Dashed lines are fits by a Gaussian waveform. (c) Temporal intensity profiles of the four channels that are time-interleaved. Each channel is recorded on the electrical sampling oscilloscope after wavelength demultiplexing.

Fig. 3 Experimental results obtained for the simultaneous processing of four channels at a repetition rate of 40 GHz with channels spaced by 400 GHz. (a) Optical spectrum. Dashed lines are fits by a Gaussian waveform. (b) Temporal intensity profiles of the four channels that are time-interleaved. Each channel is recorded on the optical sampling oscilloscope after wavelength demultiplexing. The blue circles represent a fit by a Gaussian waveform.

Figure 1

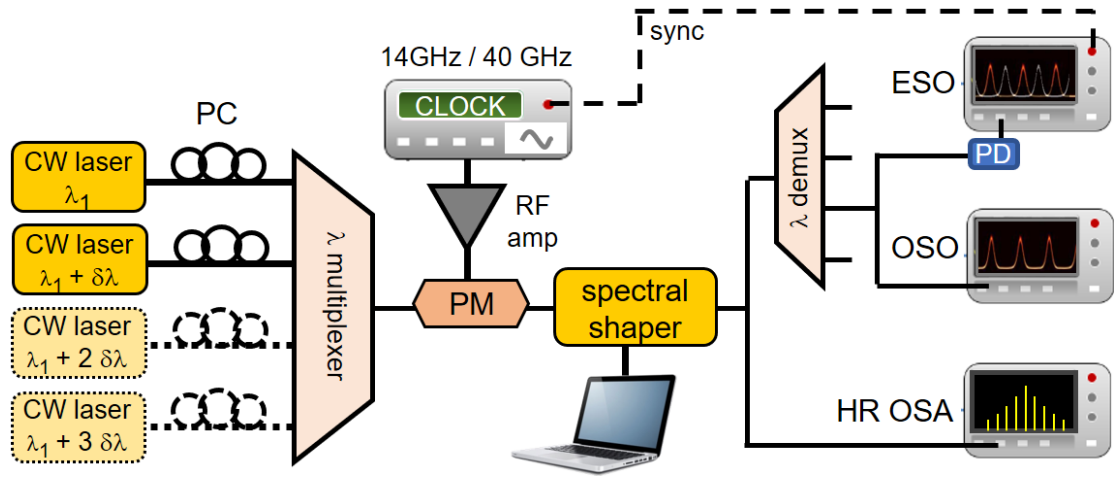

Figure 2

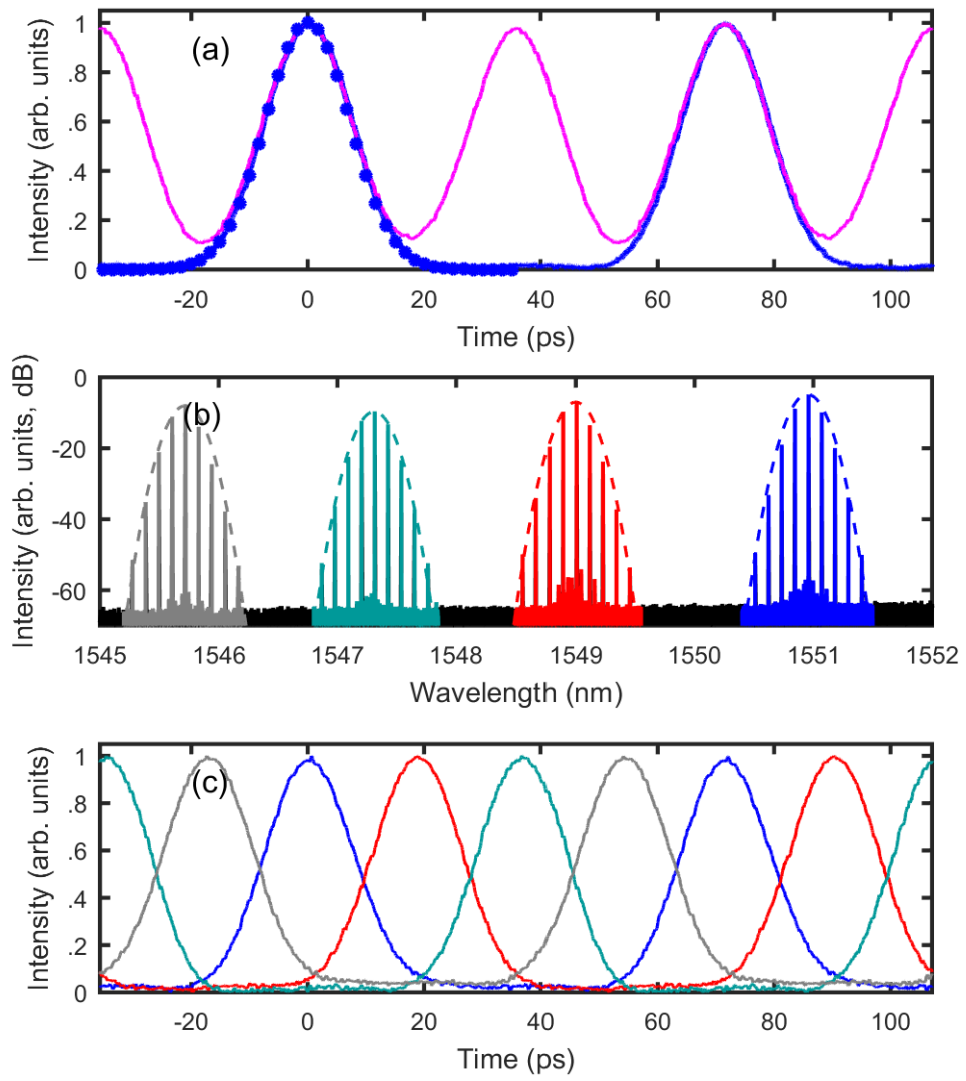
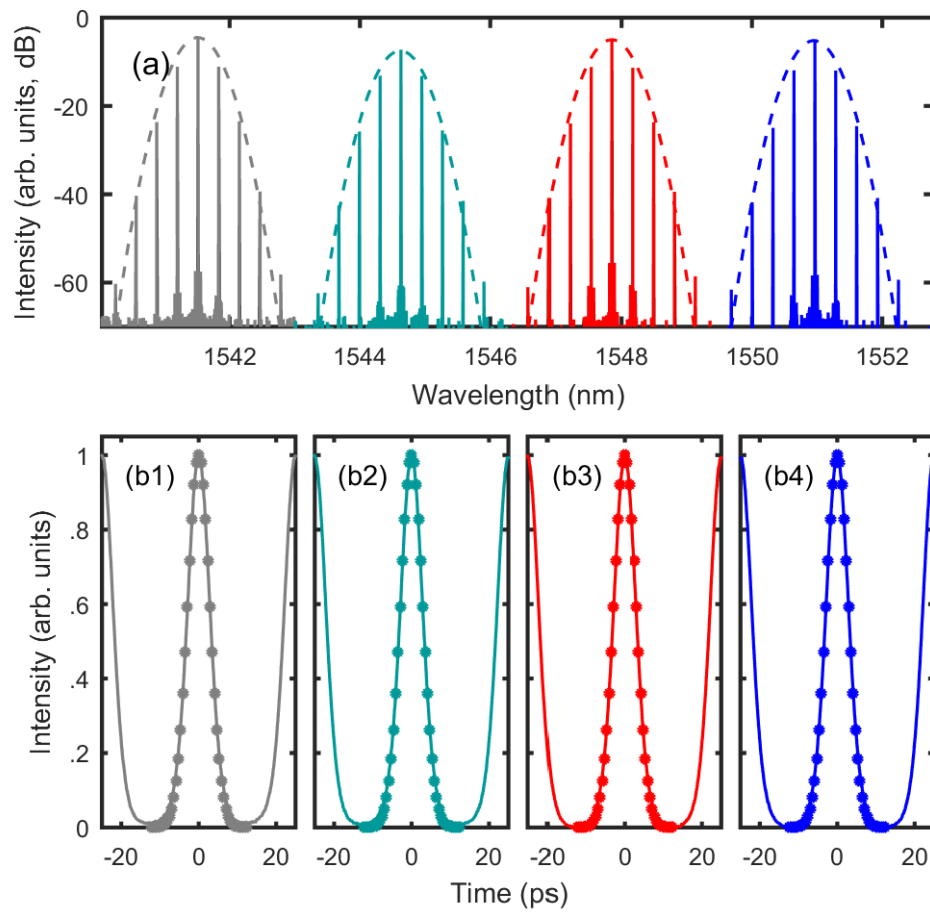

Figure 3



## References

1. Carruthers TF, Duling IN. 10-GHz, 1.3-ps erbium fiber laser employing soliton pulse shortening. *Opt Lett*. 1996;21(23):1927-1929.
2. Inoue T, Namiki S. Pulse compression techniques using highly nonlinear fibers. *Laser Photonics Rev*. 2008;2(1):83-99.
3. Pitois S, Finot C, Fatome J, Millot G. Generation of 20-GHz picosecond pulse trains in the normal and anomalous dispersion regimes of optical fibers. *Opt Commun*. 2006;260(1):301-306.
4. Finot C, Fatome J, Pitois S, Millot G. All-Fibered High-Quality Low Duty-Cycle 20-GHz and 40-GHz Picosecond Pulse Sources. *IEEE Photon Technol Lett*. 2007;19(21):1711-1713.
5. Kobayashi T, Yao H, Amano K, Fukushima Y, Morimoto A, Sueta T. Optical pulse compression using high-frequency electrooptic phase modulation. *IEEE J Quantum Electron*. 1988;24(2):382-387.
6. Komukai T, Yamamoto Y, Kawanishi S. Optical pulse generator using phase modulator and linearly chirped fiber Bragg gratings. *IEEE Photon Technol Lett*. 2005;17(8):1746-1748.
7. Jiang Z, Leaird DE, Weiner AM. Optical processing based on spectral line-by-line pulse shaping on a phase-modulated CW laser. *IEEE J Quantum Electron*. 2006;42(7):657-665.
8. Andral U, Fatome J, Kibler B, Finot C. Triangular spectral phase tailoring for the generation of high-quality picosecond pulse trains. *Submitted*. 2019:arXiv:1904.01875.
9. van Howe J, Hansryd J, Xu C. Multiwavelength pulse generator using time-lens compression. *Opt Lett*. 2004;29(13):1470-1472.
10. Hammani K, Fatome J, Finot C. Applications of sinusoidal phase modulation in temporal optics to highlight some properties of the Fourier transform. *Eur J Phys*. 2019;40:055301.
11. Roelens MAF, Frisken S, Bolger J, et al. Dispersion trimming in a reconfigurable wavelength selective switch. *J Lightw Technol*. 2008;26:73-78.
12. Torres-Company V, Fernández-Pousa CR, Chen LR. Temporal Lau effect: a multiwavelength self-imaging phenomenon. *Opt Lett*. 2009;34(12):1885-1887.

13. Parmigiani F, Finot C, Mukasa K, et al. Ultra-flat SPM-broadened spectra in a highly nonlinear fiber using parabolic pulses formed in a fiber Bragg grating. *Opt Express*. 2006;14(17):7617-7622.
14. Kippenberg TJ, Gaeta AL, Lipson M, Gorodetsky ML. Dissipative Kerr solitons in optical microresonators. *Science*. 2018;361(6402):eaan8083.