



HAL
open science

CPW-fed patch antenna with switchable polarization sense

Hakim Aïssat, Laurent Cirio, Marjorie Grzeskowiak, Jean-Marc Laheurte, Odile Picon

► **To cite this version:**

Hakim Aïssat, Laurent Cirio, Marjorie Grzeskowiak, Jean-Marc Laheurte, Odile Picon. CPW-fed patch antenna with switchable polarization sense. European Microwave Conference 2005, Oct 2005, Paris, France. pp.1-4, 10.1109/EUMC.2005.1608839 . hal-02193756

HAL Id: hal-02193756

<https://hal.science/hal-02193756>

Submitted on 24 Jul 2019

HAL is a multi-disciplinary open access archive for the deposit and dissemination of scientific research documents, whether they are published or not. The documents may come from teaching and research institutions in France or abroad, or from public or private research centers.

L'archive ouverte pluridisciplinaire **HAL**, est destinée au dépôt et à la diffusion de documents scientifiques de niveau recherche, publiés ou non, émanant des établissements d'enseignement et de recherche français ou étrangers, des laboratoires publics ou privés.



Open Archive Toulouse Archive Ouverte (OATAO)

OATAO is an open access repository that collects the work of some Toulouse researchers and makes it freely available over the web where possible.

This is an author's version published in: <https://oatao.univ-toulouse.fr/24097>

Official URL : <https://doi.org/10.1109/EUMC.2005.1608839>

To cite this version :

Aïssat, Hakim and Cirio, Laurent and Grzeskowiak, Marjorie and Laheurte, Jean-Marc and Picon, Odile CPW-fed patch antenna with switchable polarization sense. (2005) In: European Microwave Conference 2005, 4 October 2005 - 6 October 2005 (Paris, France).

Any correspondence concerning this service should be sent to the repository administrator:

tech-oatao@listes-diff.inp-toulouse.fr

CPW-fed patch antenna with switchable polarization sense.

H. Aïssat, L. Cirio, M. Grzeskowiak, J. M. Laheurte, O. Picon

University of Marne-la-Vallée, ESYCOM, 5 Bd Descartes, 77454 Marne-la-Vallée cedex 2, France

Contact: haissat@univ-mlv.fr Phone: 0160957229 Fax: 0160957214

Abstract — This paper presents the design and development of a CPW-fed microstrip patch antenna with polarization reconfigurability (RHCP/LHCP). The basic antenna is a circular microstrip antenna excited by a CPW-fed diagonal slot and a CPW open end. First, experimental and simulated results are presented for the passive antenna. Then, an active antenna using beam-lead PIN diodes to switch the polarization sense is proposed. Simulations are presented including electrical parameters for the diode modelling. The deviation between simulated and experimental results is finally discussed.

I. INTRODUCTION

A tremendous growth is currently observed in the wireless RFID market with new frequency bandwidths around 866MHz (UHF), 2.4GHz and 5.8GHz (Microwave). Typical applications cover transportation vehicle ID (road toll), access/security, large item management, supply chain. RFID systems have several advantages over comparable optical systems, such as better penetration through obstructing materials and easier electronic manipulation of the identifying signals. Microwave frequencies in particular are attractive due to wide available bandwidth for high-speed data transfer, and physically small efficient antennas.

Circular polarization (CP) modulation was presented as a powerful modulation scheme for active read/write microwave tagging system to reduce the detrimental fading loss, caused by multipath effects [1]. On the other hand, the design of a compact single feed, dual-polarized antenna is challenging when low cross polarization, wideband and efficiency are simultaneously required. Among various antenna designs, CPW-fed patch antenna is one of the most suitable candidates for RFID applications especially for the easy insertion of integrated circuits or components.

To obtain a compact structure, switching is achieved by using several PIN diodes directly mounted on the CPW feed-line. By shortening one or several diodes, a specific polarization sense can be excited in the patch antenna.

II. CIRCULARLY POLARIZED PASSIVE STRUCTURE

CP can be obtained by using asymmetries [2], notches [3] or stub [4] to yield two degenerate modes with linear amplitude and 90° out of phase.

Our solution is based on a circular patch antenna [5]. CP is obtained by combining two non-orthogonal modes independently excited by an inclined slot and the open termination end of the CPW feed-line (Fig.1).

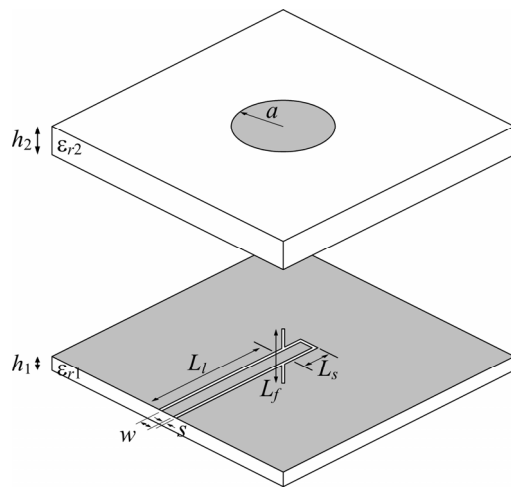

Fig. 1: Circularly polarized passive structure.
 $h_1 = 1.524\text{mm} - \epsilon_{r1} = 4.5 - h_2 = 3.175\text{mm} - \epsilon_{r2} = 2.2$
 $L_l = 32\text{mm} - L_s = 5.8\text{mm} - L_f = 20.6\text{mm} - a = 9\text{mm}$
 $w = 3.5\text{mm} - s = 0.5\text{mm}$.

This structure only presents two metallization levels and makes easier the integration of active devices. It allows the realization of series as well as shunt connections on one side of the substrate, avoiding via hole connections. The permittivity of the upper substrate (DUROID 5880) is low to optimise the radiation characteristic of the antenna while the permittivity of the lower substrate is high (TMM4) to reduce the size of the CPW feed-line. The phase difference and amplitude can be adjusted by tuning the available parameters (length L_s , length L_a and the thickness h_1 of the substrate).

Fig. 2 describes the main results on simulated and measured VSWR and axial ratio (AR) at boresight. On this figure, an air gap of 70 μm (due to the stacked substrates including the TMM4 and DUROID 5880) has been taken into account in our simulations.

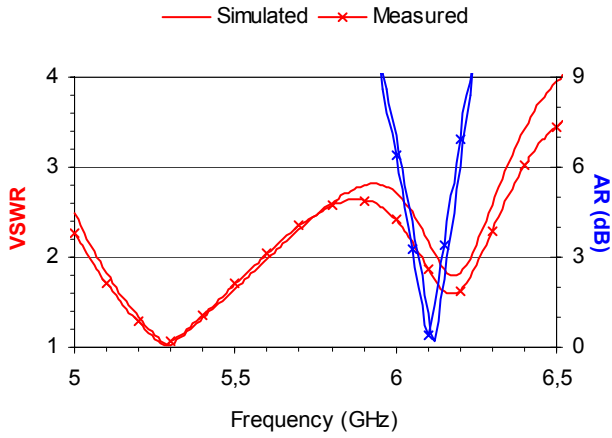

Fig. 2: Simulated and measured VSWR and AR.

The simulated and measured normalised radiation patterns (for the minimum of AR) are respectively represented on the Fig. 3 and 4.

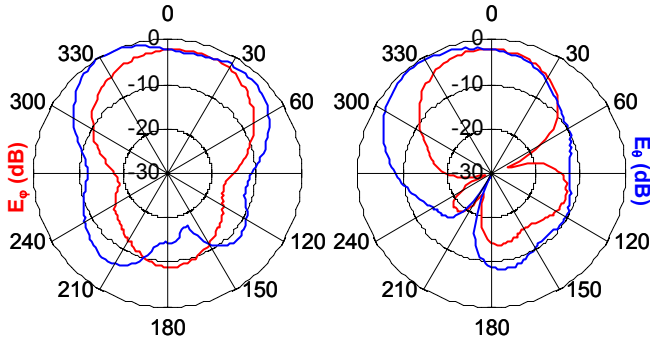

Fig. 3: Simulated radiation pattern.

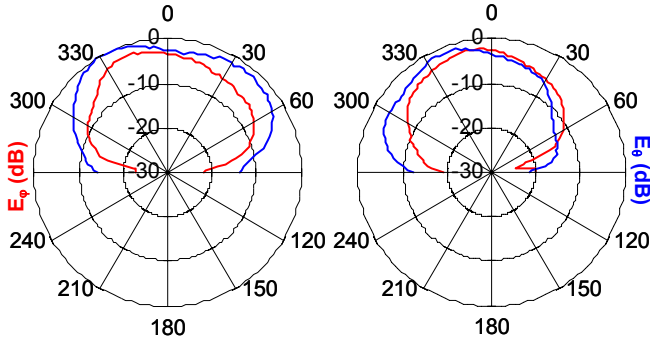

Fig. 4: Measured Radiation pattern.

A good agreement is observed between simulated and measured results for the passive structure with similar E_θ and E_ϕ levels around boresight.

III ANTENNA WITH SWITCHABLE POLARIZATION SENSE

The active antenna is derived from the passive structure by adding a symmetrical slot along the other

diagonal (Fig. 5). Each slot can be short-circuited by means of a pair of beam-lead PIN diodes (HPND-4028 Agilent Technologies) located near the intersection with the feeding line. The polarization sense of the antenna can then be switched between RHCP and LHCP by shorting either slot. By switching ON a pair of diodes while the other is OFF, one can select the polarization sense. However, the design of the DC-bias network is delicate because the DC connection on the ground plane must not interfere with RF signal. Here, the DC-bias voltage is directly supplied through a divided ground plane. This one is separated into four parts using four thin slots ($127\mu\text{m}$). The slots are covered by an adhesive layer (approximately $60\mu\text{m}$) which insures DC isolation but also appreciably modify the behaviour of the structure. The adhesive layer is topped with adhesive copper to shield these slots at RF frequencies.

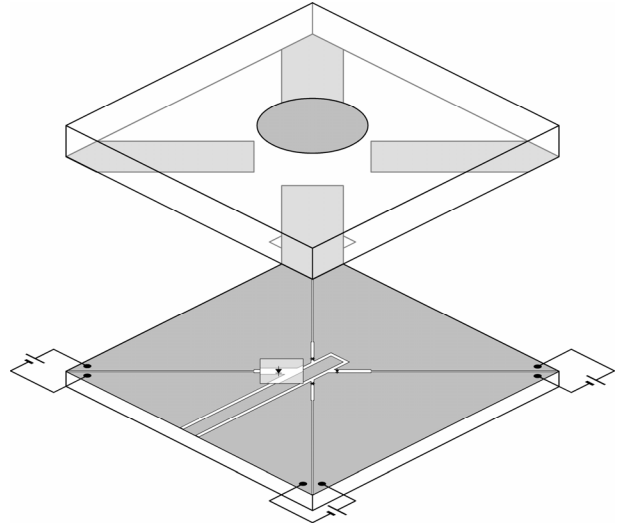

Fig. 5: Circularly polarized active structure.

Beam-lead PIN diodes used for the switching require a 10mA forward bias current in the forward state (ON) and -10V reverse voltage in the reverse state (OFF).

All the simulations were performed with Ansoft HFSS. First, a $110\mu\text{m}$ wide strip was used to ideally model the PIN diode in the forward state and an infinite resistance in the reverse state. The simulated and measured results are depicted on Fig. 6 and 7 for both RHCP and LHCP. We can see a 150MHz shift of the minimum VSWR between measured and simulated results. A sensitive degradation on the AR level is also observed. This minimum must be improved to reach acceptable AR ratios ($<3\text{dB}$). The frequency shift between the minimum measured AR for RHCP and LHCP is lower than 1%. A 100MHz shift of the central CP frequency is observed between measured and simulated AR.

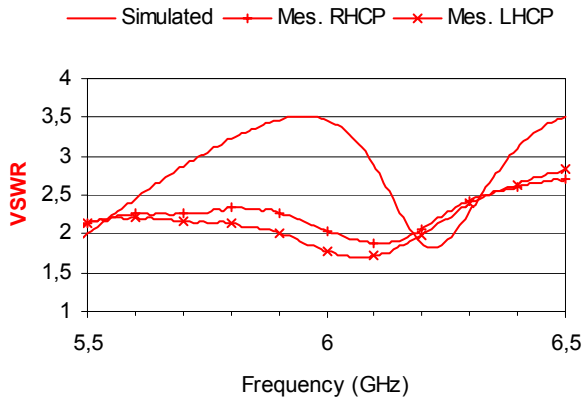

Fig. 6: Results of VSWR with an ideal model of the diode.

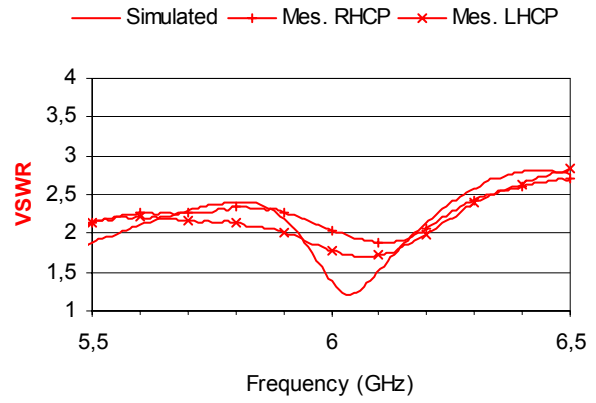

Fig. 9: Results of VSWR with an electrical model of the diode.

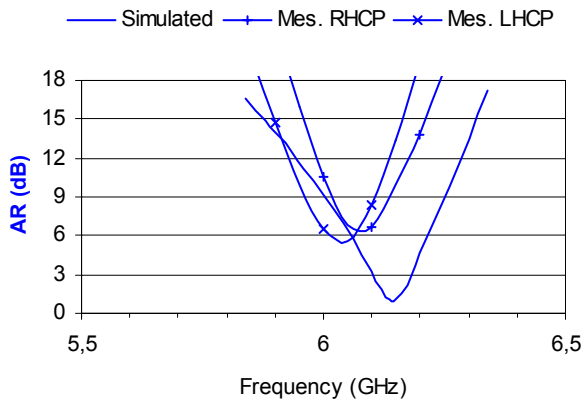

Fig. 7: Results of AR with an ideal model of the diode.

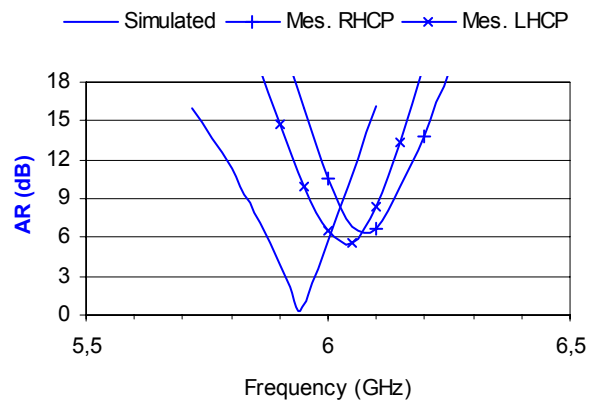

Fig. 10: Results of AR with an electrical model of the diode.

To improve the simulated results, two electrical models of the HPND-4028 PIN diode have been integrated in the HFSS simulator for the forward state and the reverse one (Fig. 8). The values of the lumped parallel elements (capacitor, resistor and inductor) have been extracted from the [S] parameters given by the Agilent Technologies data at 6GHz.

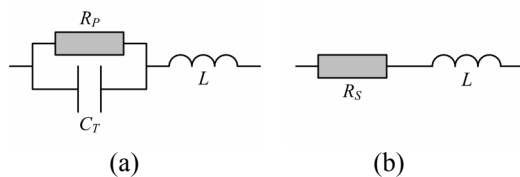

Fig. 8: Electrical model of the diode.
 (a) OFF $C_T=36.02\text{fF}$ (L and R_P are negligible)
 (b) ON $R_S=2.4\Omega$ and $L=235.62\text{pH}$

The simulation results for VSWR are in good agreement with measurement and clearly improved when compared to the ideal model (Fig. 9 and 10). The simulated AR is shifted from 6.14GHz to 5.94GHz with the electrical models of the diode. These results prove the great AR sensitivity to the diode model. Moreover, the parasitic radiation of the diode inside the CPW is not taken into account by the modelling and probably contributes to the AR degradation.

The simulated radiation pattern obtained in RHCP configuration is shown in Fig. 11. Similar curves were obtained for LHCP.

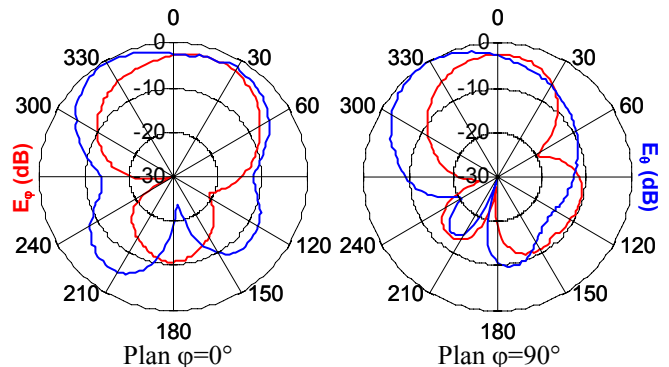

Fig. 11: Simulated radiation pattern.

IV. CONCLUSION

A reconfigurable CPW-single fed antenna has been developed for RFID systems requiring polarization modulation. To obtain a compact structure, the switchable device (PIN diodes) has been directly integrated below the radiating element on the CPW feedline. However, the vicinity of the diodes degrades the radiation performances of the antenna. The switchable polarization sense has been clearly put in evidence and its

potential integration in a RFID system has been highlighted.

ACKNOWLEDGEMENT

The authors would like to thank D. Delcroix (ESYCOM, France) and R. Ringot (IEMN, France) for the antennas realizations.

REFERENCES

- [1] S. Fang, "A novel polarisation diversity antenna for WLAN application," in *IEEE AP-S Dig.*, vol. 1, Salt Lake City, Utah, USA, July 2000, pp. 282-285.
- [2] J. S. Chen, "A CPW-fed dual-frequency rectangular patch antenna," *Microwave and Optical Technology Letters*, vol. 34, no 5, pp. 397-398, September 2002.
- [3] C. Y. Huang, K. L. Wong "Coplanar waveguide-fed circularly polarised microstrip antenna," *IEEE Trans. on Microwave Theory and Tech.*, vol. 48, no 2, pp. 328-329, February 2000.
- [4] C. Y. Huang "A circularly polarized microstrip antenna using a coplanar-waveguide feed with an inset tuning stub," *Microwave and Optical Technology Letters*, vol. 28, no 5, pp. 311-312, March 2001.
- [5] H. Aïssat, L. Cirio, M. Greskowiak, J. M. Laheurte, O. Picon "Circularly polarized planar antenna excited by coplanar waveguide feedline," *Electronics letters*, vol. 40, no 7, pp. 402-403, April 2004.