



**HAL**  
open science

## Consistent Coupled Optical and Thermal Analysis of Volumetric Solar Receivers with Honeycomb Absorbers

Mahmoud Mahmoud Alaa Ali, Mohamed Rady, Mohamed Attia, Emad Ewais

► **To cite this version:**

Mahmoud Mahmoud Alaa Ali, Mohamed Rady, Mohamed Attia, Emad Ewais. Consistent Coupled Optical and Thermal Analysis of Volumetric Solar Receivers with Honeycomb Absorbers. *Renewable Energy*, 2019, 145, pp.1849-1861. 10.1016/j.renene.2019.07.082 . hal-02185255

**HAL Id: hal-02185255**

**<https://hal.science/hal-02185255v1>**

Submitted on 18 Aug 2019

**HAL** is a multi-disciplinary open access archive for the deposit and dissemination of scientific research documents, whether they are published or not. The documents may come from teaching and research institutions in France or abroad, or from public or private research centers.

L'archive ouverte pluridisciplinaire **HAL**, est destinée au dépôt et à la diffusion de documents scientifiques de niveau recherche, publiés ou non, émanant des établissements d'enseignement et de recherche français ou étrangers, des laboratoires publics ou privés.

# Accepted Manuscript

Consistent coupled optical and thermal analysis of volumetric solar receivers with honeycomb absorbers

Mahmoud Ali, Mohamed Rady, Mohamed A.A. Attia, Emad M.M. Ewais

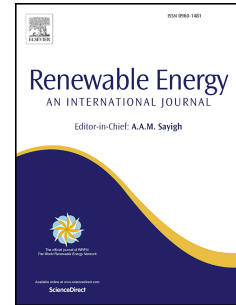

PII: S0960-1481(19)31102-4

DOI: <https://doi.org/10.1016/j.renene.2019.07.082>

Reference: RENE 11994

To appear in: *Renewable Energy*

Received Date: 14 May 2019

Revised Date: 9 July 2019

Accepted Date: 15 July 2019

Please cite this article as: Ali M, Rady M, Attia MAA, Ewais EMM, Consistent coupled optical and thermal analysis of volumetric solar receivers with honeycomb absorbers, *Renewable Energy* (2019), doi: <https://doi.org/10.1016/j.renene.2019.07.082>.

This is a PDF file of an unedited manuscript that has been accepted for publication. As a service to our customers we are providing this early version of the manuscript. The manuscript will undergo copyediting, typesetting, and review of the resulting proof before it is published in its final form. Please note that during the production process errors may be discovered which could affect the content, and all legal disclaimers that apply to the journal pertain.

# Consistent Coupled Optical and Thermal Analysis of Volumetric Solar Receivers with Honeycomb Absorbers

Mahmoud Ali <sup>a,c,\*</sup>, Mohamed Rady <sup>b,†</sup>, Mohamed A. A. Attia <sup>c</sup>, Emad M. M. Ewais <sup>d</sup>

<sup>a</sup> Univ. Orléans, Univ. Tours, INSA-CVL, LaMé (EA 7494), 8 rue Léonard de Vinci, 45072 Orléans, France

<sup>b</sup> Mechanical Engineering Department, Faculty of Engineering at Rabigh, King Abdulaziz University, KSA

<sup>c</sup> Mechanical Engineering Department, Faculty of Engineering at Helwan, Helwan University, 11792 Helwan, Cairo, Egypt.

<sup>d</sup> Refractory and Ceramic Materials Division, Central Metallurgical R&D Institute (CMRDI), 11421 Helwan, Cairo, Egypt.

## Abstract

In concentrating solar power plants with central towers, successful design of volumetric solar receivers requires proper understanding of the interaction between optical, heat transfer, and fluid flow phenomena occurring at the microscopic scale of receiver structure material and their effect on the overall solar to thermal efficiency. In the present article, coupled, 3D, optical, heat transfer and fluid flow numerical models have been developed for the analysis and design of honeycomb volumetric receiver modules. The optical model considers the absorptivity and micro dimensions of honeycomb absorber structure and employs a Monte Carlo ray tracing technique to calculate and analyze the absorbed solar heat flux distribution. This, in turn, is employed as a volumetric heat source term at the solid surface for consistent heat transfer and fluid flow modeling using a realistic solution domain and proper boundary conditions. The validated models have been employed to investigate the effects of different types of absorber materials, material absorptivity, and air flow rate on the performance of the solar receiver. It has been shown that positive volumetric effect and high solar-to-thermal efficiency can be obtained by controlling the absorbed radiation heat flux distribution within the honeycomb receiver using surface coating of the absorber material.

**Keywords:** Concentrated solar power; volumetric solar receiver; absorptivity; porous ceramics; Monte Carlo ray tracing; CFD

---

\* [mahmoud.ali@univ-orleans.fr](mailto:mahmoud.ali@univ-orleans.fr) (Mahmoud ALI)

† [mradhi@kau.edu.sa](mailto:mradhi@kau.edu.sa) (Mohamed Rady)

## 1 Nomenclature

$A$	Surface area, m <sup>2</sup>	<b>Greek Symbols</b>	
$c_p$	Specific heat, J/kg K	$\alpha$	Absorptivity
$d_{ch.}$	Honeycomb channel diameter, mm	$\beta$	Incidence angle
$h$	Heat transfer coefficient, W/m <sup>2</sup> K	$\varepsilon$	Emissivity
$K$	Thermal conductivity, W/m K	$\Theta_R$	Receiver tilt angle
$L_{ch.}$	Axial depth, mm	$\eta_{opt.}$	Optical efficiency
$\dot{m}$	Mass flow rate, kg/s	$\eta_{Th.}$	Thermal efficiency
$N_{abs.}$	Number of absorbed photons	$\mu$	Dynamic viscosity, kg/m s
$N_t$	Total number of photons	$\rho$	Density, Kg/m <sup>3</sup>
$PPP$	Power per photon, W	$\sigma$	Stefan-Boltzmann constant, W/m <sup>2</sup> K <sup>4</sup>
$P_{air}$	Rate of heat transfer to air, W	<b>Subscripts</b>	
$P_{abs}$	Absorbed solar power, W	$f$	Fluid
$P_{Sol.}$	Solar power, W	$in$	Inlet
$q_{Sol.}^*$	Absorbed solar heat flux, W/m <sup>2</sup>	$out$	Outlet
$q_{in,k}$	Energy flux incident on the surface $k$ (W/m <sup>2</sup> )	$s$	Solid
$q_{out,k}$	Radiative heat flux leaving surface $k$ (W/m <sup>2</sup> )	$amb.$	Ambient
$Q_{conv}$	Convective heat losses, W	$h$	heliostat
$Q_{rad}$	Radiative heat losses, W		
$S_v$	Volumetric heat source, W/m <sup>3</sup>		
$T_{s,z \rightarrow 0}$	Front wall temperature, K		
$T$	Temperature, K		
$u$	Air velocity, m/s		
$V_s$	Solid volume, m <sup>3</sup>		

## 1 **1. Introduction**

2 Concentrating Solar Power (CSP) is a promising and sustainable technology for electricity  
3 generation, chemical fuels production, solar heating and cooling, and water desalination [1–4].  
4 Many types of CSP technologies have been utilized for electricity production such as solar tower  
5 power plants (STPPs), parabolic trough, parabolic dish, and linear Fresnel solar collectors [5].  
6 Among the several types of CSP technologies, STPP with open volumetric solar receiver is one  
7 of the most promising technologies [6].

8 STPP is based on the concept of reflecting and concentrating sunlight, using sun-tracking  
9 mirrors (heliostats), on the receiver at the top of a central tower. The volumetric solar receiver  
10 (VSR) absorbs the solar radiation and converts it to high-temperature heat. Then, a heat  
11 transfer fluid (HTF) fluid flows through the receiver and removes the high-temperature heat by  
12 forced convection mechanism [7]. This heat is finally used to generate electricity using steam or  
13 gas turbine power plants [8]. Air is commonly used as a HTF due to its availability and stability.

14 In a typical solar tower power plant, VSR is a key element that determines the solar-to-  
15 thermal efficiency of the plant. In order to reduce the thermal losses from the VSR to the  
16 environment, the outlet temperature of the HTF should be higher than the absorber frontal  
17 surface temperature indicating what is referred to in the literature as positive volumetric effect  
18 However, all VSR tested to date show high negative values of volumetric effect [8,9].

19 Different volumetric solar receivers' designs have been investigated numerically and  
20 experimentally. They differ by the structure and the material of the receiver. Both ceramic as  
21 well as metallic materials have been tested [10–22]. Different structures include extruded  
22 honeycombs with parallel channels [19,20], wire meshes [14,15], ceramic foams [23–27], and  
23 printed structures [28]. Silicon carbide (SiC) honeycomb absorber structure has been used in  
24 many STPPs such as SolAir3000 power plant [22].

## 25 **2. Literature survey**

26 Several numerical and experimental studies have been carried out to investigate the optical  
27 and thermal performance of VSRs using ceramic honeycombs as an absorber. Figure 1 shows  
28 the volumetric solar receiver geometry and the components of a VSR module with honeycomb  
29 absorber. Different scales of interaction between optical and thermal phenomena can be  
30 envisaged from this figure. Previous numerical studies reported in the literature employed a

1 physical model at the channel scale and focused on analyzing the influence of channel  
 2 dimensions, such as channel width and wall thickness [29–32] and channel cross-section shape  
 3 [33] on the performance of the receiver. The important findings of these studies are  
 4 summarized below.

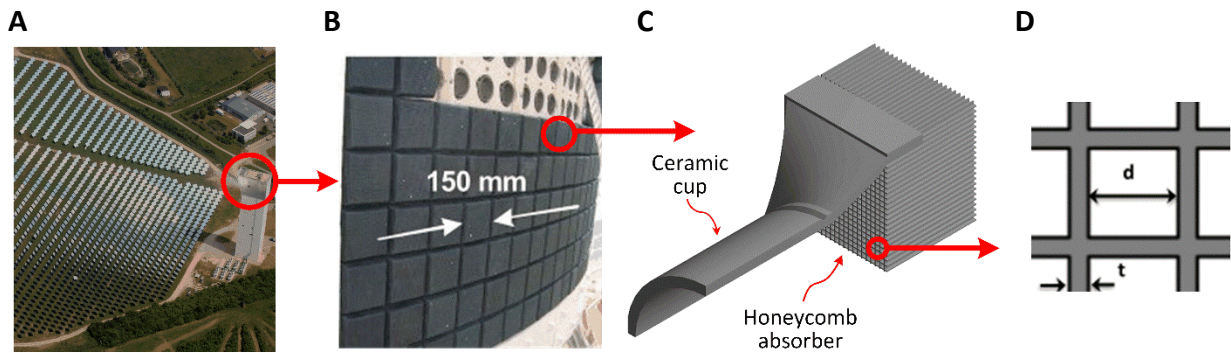

Fig. 1. Central receiver solar plant with honeycomb volumetric absorber: (A) Plant scale [30], (B) Receiver front area [30], (C) Single Module absorber and cup, (D) Channel dimensions

5 Fend et al. [30] carried out numerical and experimental studies to analyze the influence of  
 6 channel dimensions on the thermal performance of the receiver. Two SiC honeycomb samples  
 7 with different geometric parameters have been investigated. For sample 1:  $d = 2.18$  mm &  $t =$   
 8  $0.55$  mm and for sample 2:  $d = 1.43$  mm &  $t = 0.25$  mm. The radiative heat flux distribution on  
 9 the absorber surface has been estimated using one dimensional Beer Lambert Law (BLL) and  
 10 has been applied as a heat source in a CFD model using COMSOL software. Their results  
 11 indicated that the sample with smaller  $d$  and  $t$  (sample 2) shows better performance in terms of  
 12 air outlet temperature and thermal efficiency due to the increased specific surface area.  
 13 However, in both cases, the air outlet temperature was less than the frontal surface  
 14 temperature of the solid absorber indicating negative values of volumetric effect.

15 Lee et al. [29] used the 3D Monte Carlo ray tracing method (MCRT) and a 1-D CFD model to  
 16 investigate the influence of channel width (0.5 - 1.5 mm), wall thickness (0.15 – 0.25 mm), and  
 17 absorptivity ( $\alpha = 0.8, 1$ ) on the performance of the receiver. Their results indicate that  
 18 increasing the absorptivity leads to a decrease in the reflection losses from the frontal surface  
 19 of the receiver and enhance the receiver performance. In agreement with Fend et al. [30], they  
 20 found that honeycomb channels with smaller channel width showed favorable performance in  
 21 terms of HTF outlet temperature and thermal efficiency. However, Sanchez et al. [31] and  
 22 Cagnoli et al. [32], using ray tracing code and CFD model, have shown that favorable  
 23 honeycomb receiver performance has been obtained by increasing the channel width.

1 It should be noted that the previous studies differ in using either simple one-dimensional  
2 Beer Lambert law [30,33–35] or 3D Monte Carlo ray tracing [29,32,36] for performing the  
3 optical analysis of the receiver and estimating the radiative heat flux distribution on the  
4 absorber surface at the scale of single channel dimensions. The later represents the main heat  
5 source that may significantly affect the thermal performance of the receiver. Gomez-Garcia et  
6 al. [36] show that BLL can be used to describe the radiative heat flux distribution within the  
7 honeycomb structure near the entrance of the channel only for depths below two pitches.  
8 Moreover, BLL neglects the direction effects of the incoming solar rays as well as rays scattering  
9 inside the honeycomb channel. Therefore, using BLL may lead to improper characterization of  
10 the radiative flux distribution and overestimation of the HTF outlet temperature. Further  
11 analysis to clarify these points and in-depth analysis for the proper choice of the solution  
12 domain for consistent numerical modeling of the coupled optical and thermal phenomena  
13 inside the receiver represent one of the main objectives of the present article.

14 Previous studies focused on using a material with high absorptivity (SiC) to reduce the  
15 reflection losses from the frontal surface of the receiver and increase the optical efficiency [32].  
16 Numerical studies carried out by Yilbas and Shuja [33] and Kasaeian et al. [37] indicate that cell  
17 configuration with triangular channel cross-section results in higher air outlet temperature and  
18 higher thermal efficiency and then followed by square, rectangular, hexagonal, and circular  
19 cross-sections. However, negative values of volumetric effect have been observed for all shapes  
20 of channel cross-sections evaluated. Gomez-Garcia et al. [36] performed a numerical optical  
21 study, using MCRT method, and show that an increase in the penetration depth of  
22 concentrated solar radiation can be obtained by using a novel solar receiver composed of a  
23 stack of thick square grid.

24 In order to achieve the required positive volumetric effect and high solar-to-thermal-  
25 efficiency, radiation propagation within the honeycomb receiver should be maximized [8]. Both  
26 the architecture and the high absorptivity of SiC honeycombs limits radiation propagation  
27 inside the honeycomb channel. As a result, the maximum penetration depth of the absorbed  
28 heat flux is usually less than 3.3 times the channel width [29]. This leads to higher temperature  
29 at the frontal surface of the receiver, higher emission losses, lower solar-to-thermal efficiency,  
30 and lower air outlet temperature.

31

### 1 3. Outline and Contribution of Present Work

2 The major contributions of the present article and significant differences with previous  
3 reported work can be summarized as follows:

- 4 • Consistent numerical modeling of the coupled optical and thermal phenomena inside  
5 the volumetric receiver including proper solution domain, boundary conditions,  
6 optical modelling, radiation effects, and absorbed solar radiation distribution.
- 7 • Demonstration of the basic concepts to obtain positive values of volumetric effect  
8 and high solar-to-thermal efficiency for volumetric receivers. The essential  
9 requirement is shown to increase radiation propagation within the honeycomb  
10 receiver. However, both the architecture and the high absorptivity of SiC  
11 honeycombs have been shown to limit radiation propagation inside the honeycomb  
12 channel.
- 13 • An efficient method to maximize the penetration depth within the honeycomb  
14 absorber is introduced by judicious control of the absorptivity of the honeycomb  
15 channel along its length. Of course, the solar absorptivity of the frontal surface  
16 should be as maximum as possible to reduce the reflection losses. However; the  
17 absorptivity of the internal walls can be controlled to achieve the required radiation  
18 flux distribution and obtain favorable temperature distributions. According to the  
19 author's knowledge, this method has not been yet studied in previous research work.
- 20 • A novel honeycomb receiver made of Alumina has been introduced by using judicious  
21 surface coating of the absorber material. The coating has been designed with the  
22 objective of reducing the reflection losses from the frontal surface and increasing the  
23 penetration depth of the absorbed solar heat flux inside the honeycomb receiver  
24 channel. The new introduced coated Alumina honeycomb absorbers show a  
25 favorable receiver performance in terms of air outlet temperature and solar-to-  
26 thermal efficiency compared to conventional SiC honeycomb absorbers.
- 27 • The proposed method can be applied to improve the performance of honeycomb  
28 volumetric receivers.

29 The present article is organized as follows: section 4 describes the physical model for the  
30 optical and CFD analysis. The heat transfer and Fluid Flow Modeling are illustrated in section 5.



1 In section 6, the results of coupled optical and thermal models are presented and discussed.  
 2 Conclusions and key findings of the present study are presented in section 8.

### 3 4. Physical Models for Optical and CFD Analysis

4 Actually, the physical model for solar tower power plant consists of sun-tracking mirrors  
 5 (heliostats) reflecting and concentrating sunlight on the receiver. However, in laboratory  
 6 testing, solar furnace facilities are used to investigate the thermal and optical performance of  
 7 VSRs due to high concentration ratios and high temperatures that can be achieved by these  
 8 systems [38]. As shown in Fig. 2, the solar furnace used in the present study is similar to the  
 9 facility used in [24] and composed of a reflector, a parabolic concentrator, and a VSR target  
 10 similar to the one used in SolAir 3000. The total surface area of the reflector and the  
 11 concentrator are  $27 \text{ m}^2$  and  $13.5 \text{ m}^2$ , respectively. The focal distance of the concentrator is 3.8  
 12 m. The solar furnace system redirects and focuses the incoming sunlight onto the receiver  
 13 module surface. The total depth of the absorber (Z) is 50 mm with channels of square cross-  
 14 section. The honeycomb absorber receives the radiative flux and converts it to high-  
 15 temperature heat. Then, air flows through the receiver and removes the thermal energy by  
 16 forced convection.

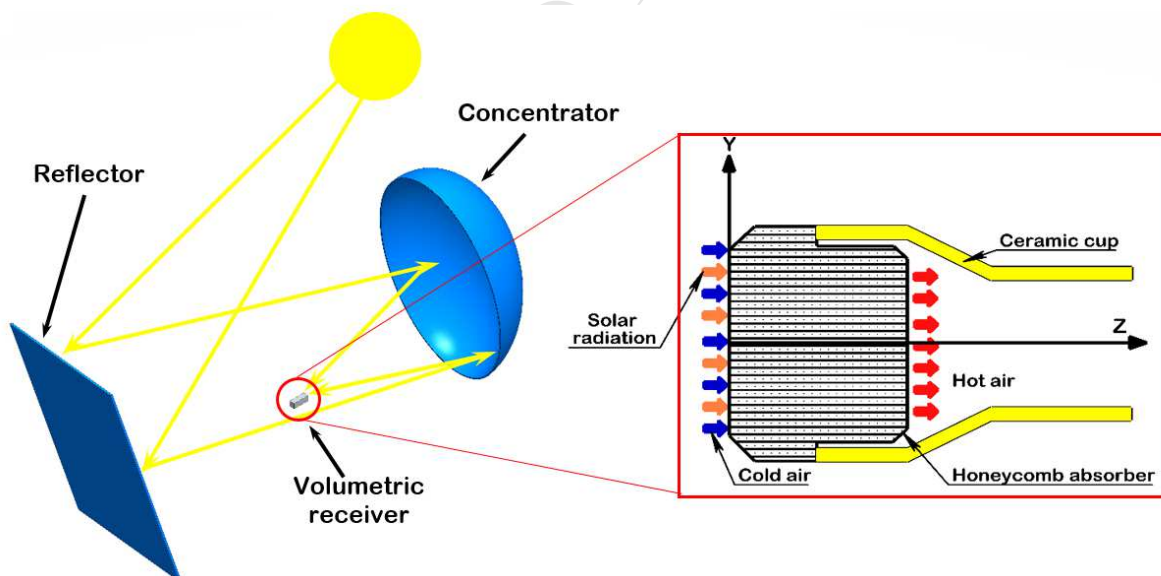

Fig. 2. Schematic diagram of the solar furnace optical model with volumetric solar receiver module.

17 The solar furnace optical model for the system shown in Fig. 2 has been developed using an  
 18 experimentally validated object-oriented Monte Carlo based ray tracing software (Tonatiuh<sup>®</sup>)  
 19 [39–41]. In a typical Tonatiuh ray-tracing simulation, the solar power is discretized into

1 photons. Each photon has the same amount of energy that represents the power per photon (  
2  $PPP$ ), which is calculated using:

$$3 \quad PPP = \frac{P_{Sol.}}{N_t} \quad (1)$$

4 Where  $P_{Sol.}$  is the solar power and  $N_t$  is the total number of photons. The sun shape has  
5 been considered as pillbox and the value of direct normal irradiation (DNI) used in the present  
6 analysis is  $1000 \text{ W/m}^2$ . Since the surface area of the receiver is smaller than the solar image  
7 reflected from the concentrator, it can be assumed that the frontal surface of the receiver ( $A$ )  
8 has a constant flux distribution. The area-averaged absorbed solar heat flux  $q_{Sol.}''$  that will be  
9 used as a source term for heat transfer analysis has been computed using:

$$10 \quad q_{Sol.}'' = \frac{PPP \times N_{abs.}}{A} \quad (2)$$

11 Where  $N_{abs.}$  is the number of absorbed photons. A sensitivity analysis has shown that a  
12 minimum number of  $10^8$  photons is required to reach an independent value of absorbed heat  
13 flux at the frontal area of the honeycomb receiver.

14 The ray-tracing algorithm is used to trace and collect the absorption and scattering data of  
15 the simulated photons through the system, starting from the light source (the sun) going  
16 towards the reflector, the concentrator and finally reaching the receiver. Ray tracing is also  
17 used for tracking the paths of the simulated photons through the receiver until they exit it or  
18 completely absorbed. This allows to determine the absorbed heat flux at each surface of the  
19 honeycomb channels (upper, lower, right, and left surfaces). Complete description of the  
20 optical model and analysis of results have been reported by the present authors elsewhere  
21 [27].

22 Tonatiuh has been designed to simulate either specular or diffuse surface behavior. The  
23 reflection mechanism of a real ceramic material depends on the manufacturing process. It is  
24 neither purely specular nor purely diffuse, but it is a mixture of the two. The effects of specular  
25 and diffuse reflectivity on the accuracy of the optical model have been addressed before by  
26 Cagnoli et al. [32]. The results show that the assumption of specular reflection is accurate  
27 enough to reproduce the actual receiver behavior. In the present study, specular directional  
28 reflectivity has been implemented in Tonatiuh.

1 The optical analysis showed that the absorptivity of the material plays a dominant role in  
 2 determining the radiative flux distribution on the honeycomb receiver surfaces. Also, the  
 3 radiative flux distribution of honeycomb absorbers is highly non-uniform with prominent peaks  
 4 and surface dependent. The latter finding is very important for consistent coupling of optical  
 5 and CFD models. This variation of solar heat flux distribution should be properly included in the  
 6 choice of physical model for CFD analysis. In the previous numerical studies [30,35], only one-  
 7 quarter of the honeycomb structure cells is used as a solution domain. This choice is valid only  
 8 when the absorbed heat flux distributions on all honeycomb structure surfaces are identical.  
 9 Therefore, in this study, an appropriate solution domain has been used as depicted in Fig. 3.  
 10 The proposed solution domain allows the authors to set the absorbed heat flux of each surface  
 11 as a standalone one in consistency with the optical analysis. Further details on the governing  
 12 equations of CFD analysis, boundary conditions implementations and mesh generation are  
 13 outlined in Section 3.

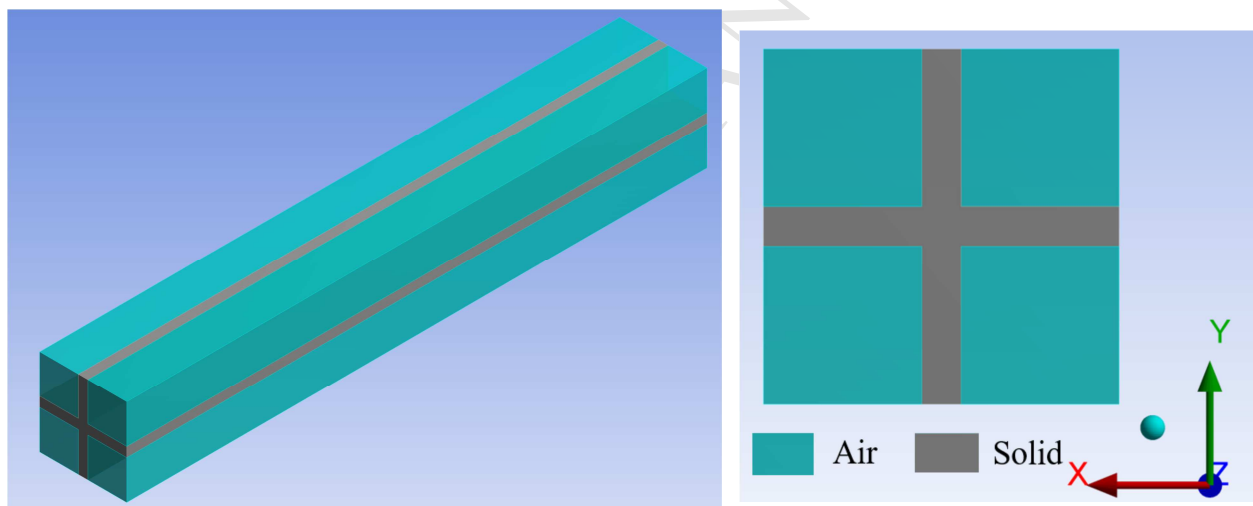

Figure 3. CFD solution domain.

## 14 5. Heat transfer and Fluid Flow Modeling

### 15 5.1 Governing Equations

16 The complete model of volumetric solar receiver couples the fluid dynamics and the  
 17 conjugate heat transfer physics. In the present study, ANSYS<sup>®</sup> software has been used for  
 18 numerical modeling of the CFD phenomena inside a single channel of the numerical solution  
 19 domain shown in Fig. 3. The solution domain comprising both fluid and solid domains has been  
 20 discretized using ANSYS<sup>®</sup> meshing software. The grid consists of tetrahedron elements as  
 21 shown in Fig. 4. In comparison with hexahedron elements, tetrahedron elements are more

1 efficient, require less computation demand, but are more complex to generate. In addition, five  
 2 inflation layers placed in the fluid domain at the interface with the solid domain in order to  
 3 solve the boundary layer where large velocity and temperature gradients usually exist. As a  
 4 measure of the mesh quality, the Skewness control has been adopted. The Skewness is a  
 5 measure of the relative distortion of an element compared to its ideal shape and is scaled from  
 6 zero (Excellent) to one (unacceptable). For all meshes created in the present work, the  
 7 Skewness value has never exceeded 0.7 indicating a good quality mesh [44].

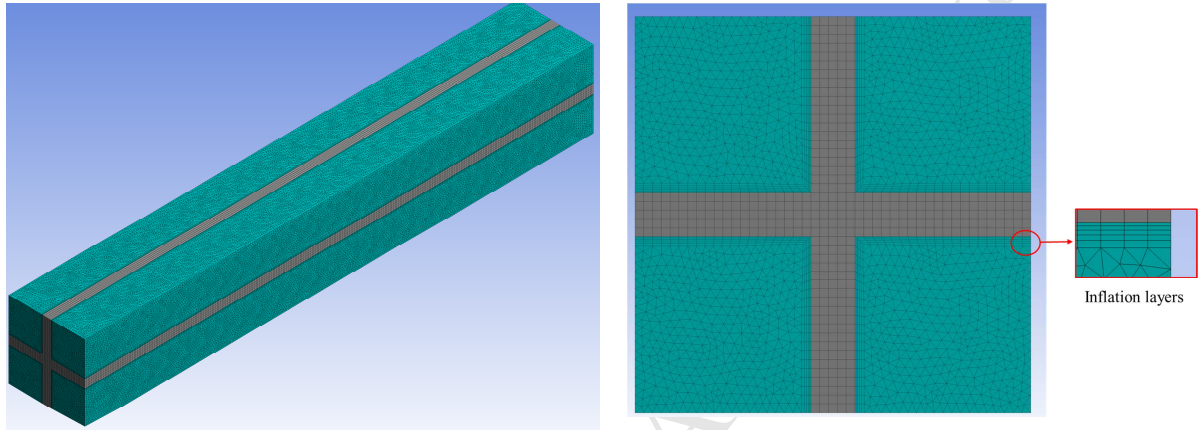

Figure 4. Numerical solution domain with generated mesh

8 The air flow inside the absorber channel is considered to be steady, incompressible and  
 9 laminar. Under these assumptions, the 3D governing continuity, momentum, and energy  
 10 equations are written as follows [42]:

$$11 \quad \frac{\partial}{\partial x_i} (\rho u_i) = 0 \quad (3)$$

$$12 \quad \frac{\partial}{\partial x_j} (\rho u_j u_i) = -\frac{dp}{dx_i} + \frac{\partial}{\partial x_j} \left( \mu \frac{\partial u_i}{\partial x_j} \right) \quad (4)$$

$$13 \quad \frac{\partial}{\partial x_i} (\rho u_i c_p T_f) = \frac{\partial}{\partial x_i} \left( K_f \frac{\partial T_f}{\partial x_i} \right) \quad (5)$$

14 The energy equation for the solid phase is written as [42]:

$$15 \quad \frac{\partial}{\partial x_i} \left( K_s \frac{\partial T_s}{\partial x_i} \right) + S_v = 0 \quad (6)$$

16 In the above equations, the subscript s refers to the solid and f refers to the fluid.

17 Where:

$\rho$	Density (Kg/m <sup>3</sup> )
$u$	Air velocity (m/s)
$\mu$	Dynamic viscosity (kg/m s)
$T$	Temperature (K)
$k$	Thermal conductivity (W/m K)
$c_p$	Specific heat (J/kg K)
$S_v$	Volumetric heat source (W/m <sup>3</sup> )

1 In the present model, energy equations for the solid and fluid phases are coupled in a  
 2 conjugate heat transfer problem. The radiative heat flux distribution obtained from the optical  
 3 simulation has been implemented as a volumetric source in the solid phase energy equation  
 4 using a User Defined Function (UDF). This source function represents the inter-linkage between  
 5 the optical and CFD models. The present volumetric source term is implemented only in the  
 6 surface control volumes of the solid phase. This is a well-known practice in modeling of surface  
 7 heat flux by an equivalent volumetric source term [43]. The solar radiation source term has  
 8 been calculated using:

$$9 \quad S_v = \frac{PPP \times N_{abs.}}{V_s} \quad (5)$$

10 Where:

$S_v$	Volumetric heat source (W/m <sup>3</sup> )
$PPP$	Power per photon (W)
$N_{abs.}$	Number of absorbed photons (-)
$V_s$	Volume of solid surface control-volume at the solid surface (m <sup>3</sup> )

11 The radiative heat transfer between the inner walls of the channel and between the inner  
 12 walls and the ambient has been taken into account using the surface to surface radiation model  
 13 (S2S) [44]. In the S2S radiation model, the surfaces are assumed to be gray and diffuse  
 14 (absorptivity is equal to the emissivity and is independent of the wavelength). Each internal  
 15 surface of the channel is divided into a number of discrete surfaces ( $k = 1: N$ ). Then view  
 16 factors, which are a function of orientation, size and distance of the  $k$  surface, are computed  
 17 [44]. The radiative heat flux leaving from one surface  $k$  to another surface is calculated  
 18 according to:

$$q_{out,k} = \varepsilon_k \sigma T_k^4 + (1 - \varepsilon_k) q_{in,k} \quad (8)$$

1 Where:

$q_{out,k}$  Radiative heat flux leaving surface  $k$  ( $W/m^2$ )

$\varepsilon_k$  Absorptivity of surface  $k$

$\sigma$  Stefan-Boltzmann constant ( $W/m^2 K^4$ )

$T_k$  Temperature of surface  $k$  (K)

$q_{in,k}$  Energy flux incident on the surface  $k$  ( $W/m^2$ )

2 In order to determine the overall performance of volumetric solar receiver, the solar to  
3 thermal efficiency ( $\eta_{s \rightarrow Th.}$ ) is calculated. The value of  $\eta_{s \rightarrow Th.}$  is an overall measurement that  
4 indicates the ratio of thermal power gain by the fluid to the incident concentrated solar  
5 radiation. The solar-to-thermal efficiency can be obtained by the following equation:

$$\eta_{s \rightarrow Th.} = \eta_{opt.} \times \eta_{Th.} = \frac{P_{abs}}{P_{in}} \times \frac{P_{air}}{P_{abs}} = \frac{\dot{m} C_p (T_{air out} - T_{air in})}{P_{in}} \quad (9)$$

6  
7 Where  $\eta_{opt.}$ ,  $\eta_{Th.}$ ,  $P_{air}$ ,  $T_{air in}$  and  $T_{air out}$  are the optical efficiency, thermal efficiency, rate of heat  
8 transfer to air, and air inlet and outlet temperatures, respectively.

## 9 5.2 Boundary Conditions

10 A constant velocity inlet boundary condition with a static temperature of 300 K has been  
11 used at the fluid domain entrance and a zero-gauge pressure outlet boundary condition has  
12 been used at the domain outlet. All contact walls between the fluid and solid domains are set  
13 to no-slip non-penetrating walls. All other surfaces have been set to symmetrical boundary  
14 conditions.

15 At the frontal surface of the receiver, the convection and radiation losses represent the  
16 boundary conditions for energy equation. The convection losses and radiation losses  
17 ( $Q_{conv.}$ ,  $Q_{rad.}$ ) are expressed as:

$$Q_{conv.} = h A_s (T_{s,z \rightarrow 0} - T_{amb.}) \quad (10)$$

$$Q_{rad.} = \sigma A_s \varepsilon (T_{s,z \rightarrow 0}^4 - T_{amb.}^4) \quad (11)$$

1 Where:

$h$  Heat transfer coefficient ( $\text{W}/\text{m}^2 \text{K}$ )

$A_s$  Front wall surface area ( $\text{m}^2$ )

$T_{s,z \rightarrow 0}$  Front wall temperature (K)

$T_{amb.}$  Ambient temperature (K)

2 The heat transfer coefficient has been taken from [6] and the ambient temperature is assumed  
3 to be 300 K.

#### 4 **5.3 Absorber Materials**

5 Ceramics are the most suitable materials for VSR due to their high operating temperature  
6 and thermal stability. In the present study, two ceramic materials have been selected and  
7 studied. These include Alumina ( $\text{Al}_2\text{O}_3$ ) and SiC. SiC is widely employed in high temperature  
8 volumetric solar receiver [45,46], due to its high absorptivity (about 0.8) [47,48], high operating  
9 temperature and good mechanical and physical properties. Alumina has been introduced in the  
10 present study for volumetric solar receiver. Alumina is a low cost well-balanced material  
11 offering high wear resistance, high mechanical strength, and thermal stability. In addition, as  
12 compared to SiC,  $\text{Al}_2\text{O}_3$  has high oxidation resistance at high temperature. However, the solar  
13 absorptivity of  $\text{Al}_2\text{O}_3$  is low (around 0.2) [49]. Optical analysis shall help in understanding the  
14 impact of its low absorptivity on the radiative flux distribution, the resulting optical efficiency  
15 and penetration depth of solar radiation in comparison with conventionally used materials such  
16 as SiC. Table 1 summarize the thermo-physical properties of SiC and  $\text{Al}_2\text{O}_3$  used in the present  
17 study. It should be noted that Silicon Carbide and Alumina used in volumetric solar receivers  
18 and implemented in the present study are opaque materials. Pure silicon carbide is colorless  
19 and transparent. However, the production of transparent, translucent, and opaque ceramics is  
20 obtained by controlling its microstructure and inclusion of impurities during the manufacturing  
21 process [50, 51]. The optical properties of  $\text{Al}_2\text{O}_3$  and SiC used in the present study have been  
22 reported in recent references [47-49, 53] dealing with characterization of materials for solar  
23 receivers. The emissivity of Alumina has been reported by P. Auerkari [53]. For wavelength up  
24 to  $2.5 \mu\text{m}$  (wavelength of interest), the average value of emissivity is around 0.2 and it  
25 decreases with increasing the temperature. The temperature dependence of thermo-physical  
26 properties of SiC,  $\text{Al}_2\text{O}_3$  and air are taken into account as listed in table 1.

1 Table 1. Thermo-physical properties of SiC, Al<sub>2</sub>O<sub>3</sub>, and air.

<b>Silicon Carbide</b>		
Property	Value	Ref.
Density ( $\rho$ ) (kg. m <sup>-3</sup> )	3100	[52]
Thermal Conductivity ( $K_s$ ) (W. m <sup>-1</sup> . K <sup>-1</sup> )	$K_s = \frac{52000e^{-1.24 \times 10^{-5} T}}{T + 437}$	[52]
Specific Heat ( $C_p$ ) (J. Kg <sup>-1</sup> . K <sup>-1</sup> )	$C_p = 1110 + 0.15T - 425e^{-0.0037T}$	[52]
Absorptivity ( $\alpha$ )(-)/Emissivity ( $\varepsilon$ )(-)	0.8	[47, 48]
<b>Alumina</b>		
Density ( $\rho$ ) (kg. m <sup>-3</sup> )	3750	[53]
Thermal Conductivity ( $K_s$ ) (W. m <sup>-1</sup> . K <sup>-1</sup> )	$K_s = -4.5536 + \frac{12227}{T}$	[54]
Specific Heat ( $C_p$ ) (J. Kg <sup>-1</sup> . K <sup>-1</sup> )	$C_p = 1429.4 - \frac{197620}{T}$	[54]
Absorptivity ( $\alpha$ )(-)/Emissivity ( $\varepsilon$ )(-)	0.2	[56, 49]
<b>Air</b>		
Viscosity ( $\mu$ ) (kg/m s)	Sutherland law	[55]
Thermal conductivity ( $K_f$ ) (W. m <sup>-1</sup> . K <sup>-1</sup> )	$K_f = 1.52 \times 10^{-11} T_f^3 - 4.86 \times 10^{-8} T_f^2 + 1.02 \times 10^{-4} T_f - 3.93 \times 10^{-3}$	[23]
Specific heat ( $C_p$ ) (J. Kg <sup>-1</sup> . K <sup>-1</sup> )	$C_p = 1.93 \times 10^{-10} T_f^4 - 8 \times 10^{-7} T_f^3 + 1.14 \times 10^{-3} T_f^2 - 4.49 \times 10^{-1} T_f + 1.06 \times 10^3$	[23]

2 **5.4 Numerical Solution Methods and Model Validation**

3 A commercial software ANSYS fluent<sup>®</sup> has been used to solve the 3-D governing equations.  
4 The SIMPLE algorithm and second-order upwind scheme have been used for pressure-velocity  
5 coupling and field variables interpolation from cell centers to the faces of the control volume.  
6 A grid independence study has been carried out by analyzing the air outlet temperature ( $T_{air\ out}$   
7 ) and the frontal surface temperature of the absorber ( $T_{solid\ in}$ ) for different grid sizes. The  
8 results are shown in table 2. It is clear that a grid with about 2,884,612 cells is fine enough.  
9 Further refinements of the grid have no effect on the results. The results have been also  
10 checked as a function of the convergence criteria and independent results have been obtained  
11 for a set value of  $10^{-6}$  for all discrete conservation equations.

12 Table 2. Grid independence study for CFD analysis.

Grid size	$T_{air\ out}$ (K)	$T_{solid\ in}$ (K)
-----------	--------------------	---------------------



601,143	1071.38	1042.65
1,242,259	1074.02	1139.12
1,802,471	1074.89	1138.82
2,884,612	1075.071	1138.40
3,142,906	1075.24	1138.38

1 In order to validate the current optical and CFD models, a comparative study has been  
 2 carried out with experimental studies available in the literature. Mey-Cloutier et al. [24]  
 3 reported experimental data for SiC honeycomb volumetric solar receiver. The experimental  
 4 work has been carried out using solar furnace facility at PROMES-CNRS Laboratory, France. The  
 5 following parameters have been collected and used as model parameters:

6 DNI = 1000 W/m<sup>2</sup>, reflector area = 27 m<sup>2</sup>, concentrator area = 13.45 m<sup>2</sup>, sample thickness = 6  
 7 cm, sample diameter = 5 cm, atmospheric pressure = 84.5 kPa and mass flow rate of air ( $\dot{m}$ ) =  
 8 1 g/s

9 Table 3 shows a comparison of air outlet temperature and absorbed solar heat flux on the  
 10 frontal surface predicted by the current model and experimental data of Mey-Cloutier et al.  
 11 [24]. It can be observed that air outlet temperature and concentrated heat flux predicted from  
 12 the present numerical model and those obtained by Mey-Cloutier et al. [24] are in a good  
 13 agreement.

14 Table 3. Comparisons of radiative heat flux and mean air outlet temperature from the  
 15 honeycomb solar receiver with the experimental data of Mey-Cloutier et al. [24].

	Experimental data [24]	Simulation results	Deviation
Concentrated solar heat flux (kW/m <sup>2</sup> )	795 ± 3%	760.25	4.371%
Air outlet temperature (K)	1170 ± 10 K	1105.27	5.53%

## 16 6. Results and Discussions

17 The previous results have demonstrated the capability of the present coupled numerical  
 18 optical and CFD models for the analysis and design of volumetric solar receivers. In the next  
 19 sections, the models shall be employed to investigate the effects of different types of absorber  
 20 materials material absorptivity, micro dimensions of the honeycomb structure, and air flow rate  
 21 on the performance of the solar receiver. Section 4.1 is devoted to the analysis of absorbed  
 22 solar heat flux distribution on different surfaces of the honeycomb solar receiver as obtained  
 23 from the optical modeling. Two different materials with high and low absorptivity, namely SiC  
 24 and Al<sub>2</sub>O<sub>3</sub> are employed. Optical analysis shall help in understanding the influence of

1 absorptivity on the radiative flux distribution, the resulting optical efficiency and penetration  
2 depth of solar radiation. New enhancement methods to improve the performance of  
3 honeycomb solar receivers are suggested. Sections 4.2 and 4.3 are devoted to the analysis of  
4 heat transfer and fluid flow inside the receiver and their effects on the overall receiver  
5 performance.

6

7

## 8 **6.1 Analysis of Absorbed Solar Heat Flux Distribution**

9 Figure 5 shows a schematic of honeycomb channel and incident solar rays. As shown in Fig.5  
10 (a), the incidence angle of solar flux ( $\beta$ ) is the angle between the normal direction to the frontal  
11 surface of the receiver and the line connecting the center of the heliostat module to the aiming  
12 point. In real commercial solar thermal power plant (actual and large receiver), thousands of  
13 heliostat modules are used to concentrate the incident solar radiation on the receiver surface  
14 and one volumetric solar receiver module may receive solar rays from multiple heliostats. As a  
15 result, there will be a range of incidence angle values and a dominant value is usually used in  
16 the analysis [32,56–59]. This dominant value can be controlled by changing the tilt angle of the  
17 receiver ( $\theta_R$ ). As can be seen in Fig. 5(b), the value of the incidence angle ( $\beta$ ) should be higher  
18 than zero to ensure that incident solar rays are not parallel to the axis of the honeycomb  
19 channel and exit the receiver without being absorbed. Previous studies show that an incidence  
20 angle less than 10 degrees will enhance the radiation propagation within the honeycomb  
21 receiver, however, some rays will exit the receiver without being absorbed [32]. Nakamura et  
22 al. [58] concluded that the effect of incidence angle from  $10^\circ$  to  $45^\circ$  on the receiver efficiency is  
23 negligible. This can be attributed to very small values of channel height as compared to  
24 channel length. Figure 6 shows a comparison of the total absorbed solar heat flux distribution  
25 using SiC honeycomb volumetric solar receiver for two different dominant incidence angles of  
26  $15^\circ$  and  $25^\circ$ . It can be observed that, there is a negligible difference the distribution of total  
27 absorbed solar heat flux along the receiver channel in agreement with the conclusion of  
28 Nakamura et al. [58]. Therefore, in the present study using the optical facility shown in Fig. 2,  
29 the range of the incident angle is  $0^\circ$  to  $25.6^\circ$  with a dominant value of  $15^\circ$  corresponding to a  
30 receiver tilt angle of  $47^\circ$ . These values have been kept constant for all optical analysis.

31

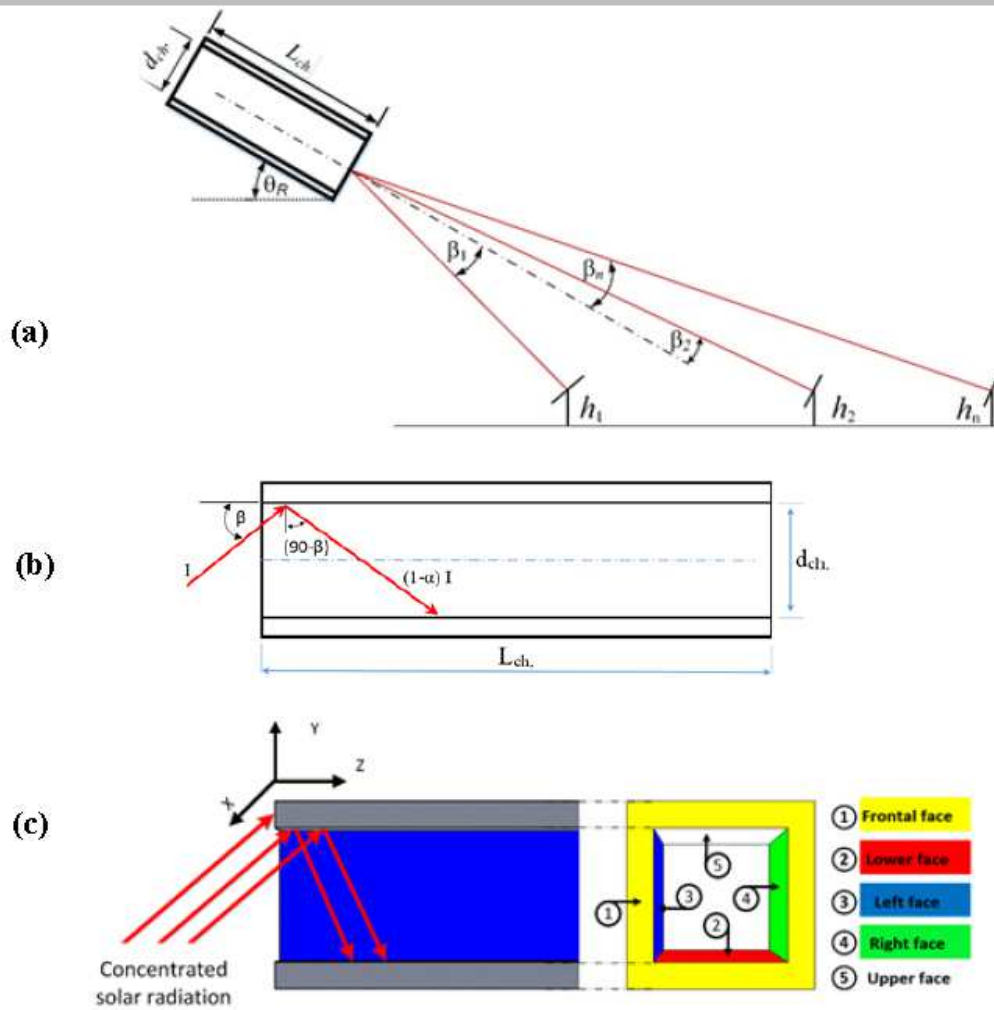

Fig. 5. Schematic of honeycomb channel and incident solar rays: (a) Solar incidence angle, (b) Incident solar ray tracing, (c) Channel surfaces

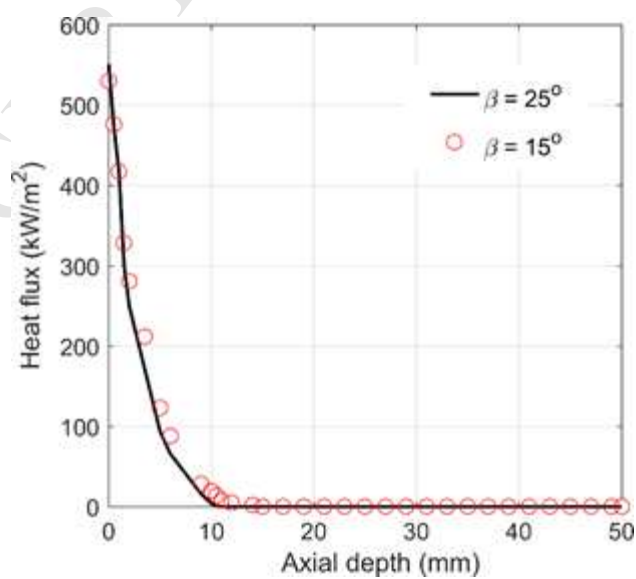

Fig. 6. Effect of incidence angle on the total absorbed solar heat flux distribution of honeycomb SiC absorber channel.

1  
2  
3

1 It can be observed from Fig. 5(c), that most of the concentrated sunlight entering the  
2 honeycomb channel firstly hit the upper surface then reflect to the other internal surfaces.  
3 Therefore, the absorptivity of the upper surface plays a dominant role in determining the  
4 radiative flux distribution on the honeycomb receiver internal surfaces. The absorbed heat flux  
5 on the upper surface increases with the increase of surface absorptivity. Correspondingly, the  
6 values of absorbed heat flux on the other internal surfaces decrease due to the small number of  
7 reflected solar rays from the upper surface.

8 Figure 7 shows a detailed absorbed heat flux distribution on different surfaces of the  
9 honeycomb channel as a function of the axial depth ( $Z$ ). For a higher absorptivity material (SiC  
10 of  $\alpha = 0.8$ ), the majority of concentrated solar radiation is intercepted by the upper surface  
11 and the flux peak is located at the entrance of the Honeycomb channel ( $Z = 0 \text{ mm}$ ). The  
12 reflected radiative power from the upper surface is absorbed by the lower surface. Thus, the  
13 radiative flux peak is located on deeper sections ( $Z$  around 7 mm). In addition, the maximum  
14 penetration depth of the radiative flux within the honeycomb absorber is less than 10 mm.  
15 Such a flux distribution with small penetration depth may lead to higher temperature at the  
16 frontal surface of the receiver as compared to the air outlet temperature from the receiver.  
17 This results in relatively higher values of thermal losses and lower values of solar to thermal  
18 efficiency.

19 In case of material with low absorptivity ( $\text{Al}_2\text{O}_3$ ), the percentage of the reflected radiative  
20 solar power from the upper surface to the lower surface is higher when compared with the  
21 percentage share of lower surface for a higher absorptivity material (SiC). However, the total  
22 absorbed radiative power by the frontal surface (see Fig. 8) and internal walls is very small  
23 compared to SiC. Optical analysis shows a multi-reflection effect in the absorber channel of  
24  $\text{Al}_2\text{O}_3$ . This results in the run-away of photons from the exit of the receiver without being  
25 absorbed. Figure 8 shows the effect of material absorptivity on the values of absorbed heat flux  
26 at the frontal surface and optical efficiency. Alumina absorbers show low values of absorbed  
27 heat flux and optical efficiency compared to SiC

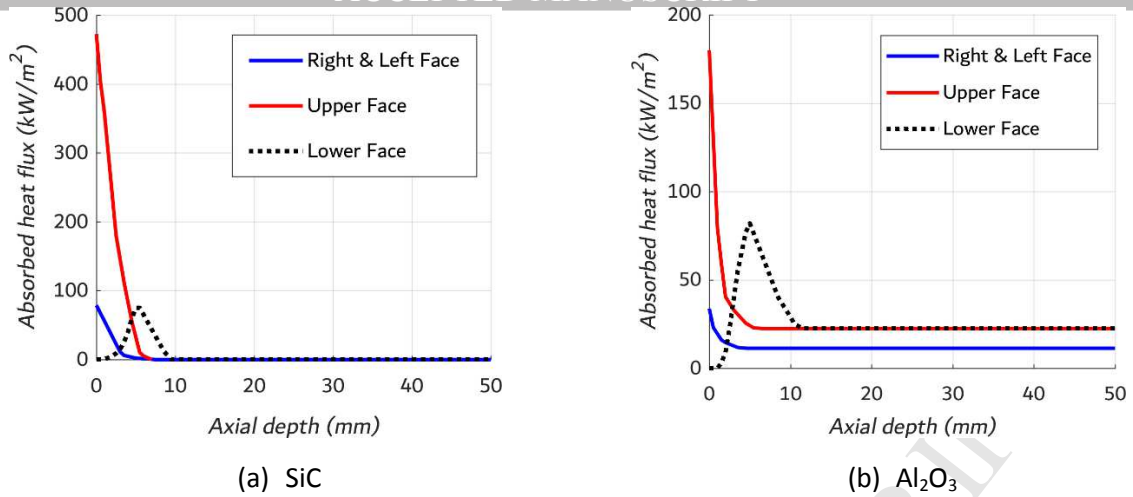

Fig. 7. Absorbed solar heat flux distribution on internal surfaces of honeycomb absorber channel for: (a) SiC; (b) Al<sub>2</sub>O<sub>3</sub>.

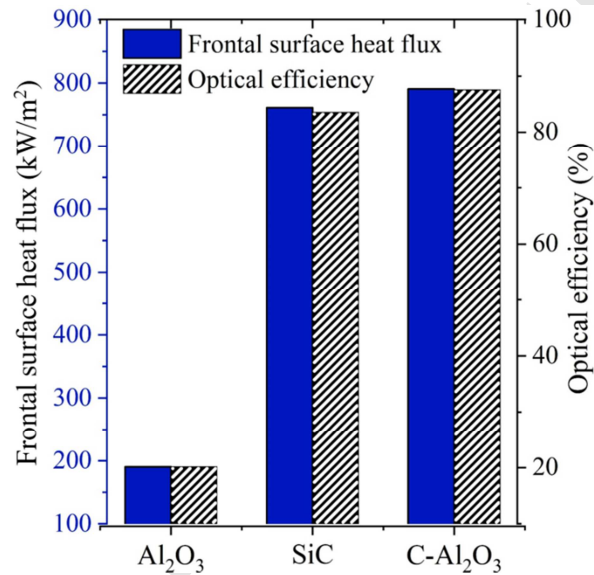

Fig.8. Effect of material absorptivity on the absorbed heat flux on frontal surface of honeycomb absorber and optical efficiency.

1 For the purpose of increasing the penetration depth of the radiative heat flux and the optical  
 2 efficiency of Al<sub>2</sub>O<sub>3</sub> honeycomb absorber, the frontal and internal surfaces of the honeycomb  
 3 channel can be coated with a high absorptivity selective coating such as Pyromark 2500<sup>®</sup> high-  
 4 temperature paint [61]. The solar absorptivity and emissivity of the coating are 0.95 and 0.9,  
 5 respectively [60]. Since most of the optical losses are due to reflection losses from the frontal  
 6 surface and photons escaping from the exit of the receiver, it is proposed to apply a selective  
 7 coating (Pyromark 2500) on the frontal surface ( $Z = 0 \text{ mm}$ ) and the last 25 mm depth from  
 8 the exit ( $Z = 50 \text{ mm}$ ) of Al<sub>2</sub>O<sub>3</sub> honeycomb absorber (see Fig. 9).

9 It should be noted that Pyromark 2500 high-temperature paint has been used on central  
 10 receivers, including the Solar One Central Receiver Pilot Plant. As reported by the

1 manufacturer, Pyromark 2500 resists temperatures up to 1093 °C. Field and laboratory tests  
 2 indicate that the solar absorptance of the coating can decrease with time at elevated  
 3 temperatures, and repainting may be required every few years [60]. Pyromark 2500 was  
 4 implemented in the analysis performed in the present study in order to employ realistic and  
 5 reasonable values of solar absorptivity and emissivity of high temperature coating materials.  
 6 The development of solar selective coatings for high-temperature solar receivers is currently a  
 7 topic of research [61]. Other superior coating materials are most likely expected to be  
 8 produced. However, the results of the present analysis shall be applicable to other coating  
 9 materials of similar values of optical properties.

10 Employment of the present suggested enhancement method, shows that the absorbed heat  
 11 flux on the frontal surface is increased to reach a value higher than that of SiC (See Fig. 8, C-  
 12  $\text{Al}_2\text{O}_3$ ). Moreover, a maximum peak of the radiative heat flux exists in all surfaces after 25 mm  
 13 from the entrance of the honeycomb channel (see Fig. 10). The second peak in absorbed solar  
 14 flux occurs, as expected, at the beginning of the suggested coating layer. Since the optical  
 15 efficiency of  $\text{Al}_2\text{O}_3$  is below 20% as can be seen in Fig. 8. This means that about 80% of the  
 16 incident solar radiation is still available for absorption in the coated part of the channel.  
 17 The absorption of this huge number of photons results in a second peak in absorbed solar heat flux  
 18 that may exceed the first peak occurring at the channel inlet section. Using this technique  
 19 results in preventing photons from escaping from the exit of the receiver, increasing the  
 20 penetration depth of the radiative heat flux, decreasing the reflection losses from the frontal  
 21 surface of the absorber and consequently increasing the optical efficiency to reach values of  
 22 about 87.56%.

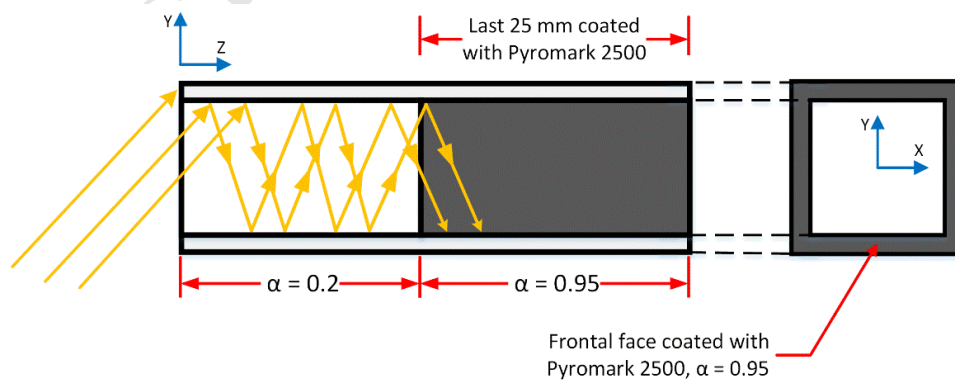

Fig.9. Schematic of present suggested enhancement method using Alumina honeycomb absorber coated with Pyromark 2500<sup>®</sup>.

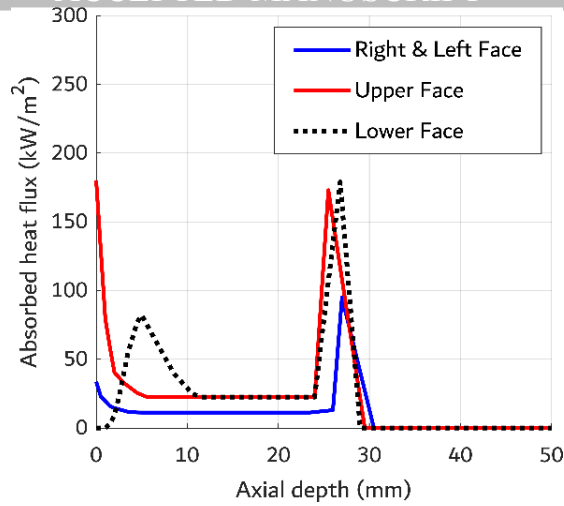
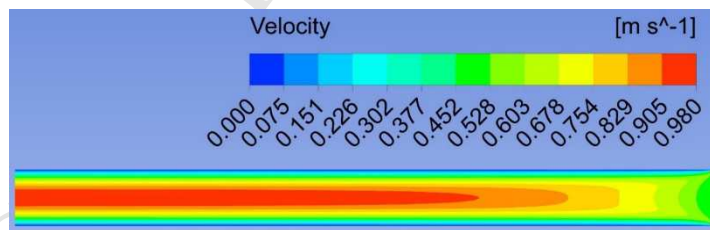

Fig. 10. Absorbed solar heat flux distribution on internal surfaces of coated alumina honeycomb absorber.

## 1 6.2 Flow Fields and Temperature Distribution

2 Numerical experiments have been carried out for honeycomb receivers for different types of  
 3 receiver materials. Volumetric solar receivers made from SiC and  $\text{Al}_2\text{O}_3$  with selective coating  
 4 (C-  $\text{Al}_2\text{O}_3$ ) as proposed in the present study have been studied.

5 Velocity and temperature fields on the axial middle plane of SiC honeycomb absorber are  
 6 shown in Fig. 11. The velocity field is represented by the magnitude of velocity vectors. The  
 7 flow can be considered fully developed before reaching half of the channel. Air enters the  
 8 channel at room temperature and its temperature increases gradually until thermal equilibrium  
 9 between the solid phase and the fluid phase is reached.



(a) Velocity field

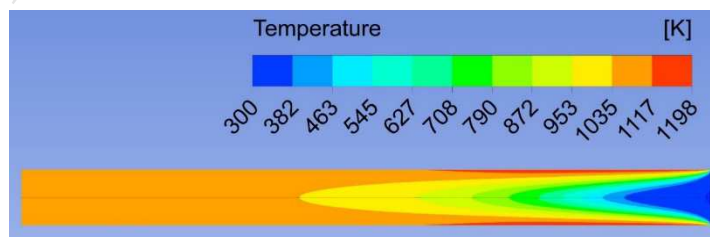

(b) Temperature field

Fig. 11. Velocity (a) and temperature fields (b) on the axial middle plane of SiC honeycomb absorber.

1 Figure 12 presents the temperature fields on the axial middle plane of  $\text{Al}_2\text{O}_3$  and C- $\text{Al}_2\text{O}_3$   
 2 honeycomb absorbers under the same inlet velocity ( $u_{in} = 0.4741 \text{ m/s}$ ). In case of  $\text{Al}_2\text{O}_3$   
 3 Honeycomb absorbers, the mean air outlet temperature is very low. The flow can be  
 4 considered as thermally developing till the exit of the channel. This can be attributed to lower  
 5 values of optical efficiency and multi-reflection effect in the absorber channel of  $\text{Al}_2\text{O}_3$ . On the  
 6 other hand, the mean air outlet temperature of C- $\text{Al}_2\text{O}_3$  honeycomb absorbers is higher and the  
 7 flow is fully developed before the exit of the channel.

(a)  $\text{Al}_2\text{O}_3$ (b) C- $\text{Al}_2\text{O}_3$ 

Fig. 12. Temperature field on the axial middle plane of a honeycomb absorber made of (a)  $\text{Al}_2\text{O}_3$   
 and (b) C- $\text{Al}_2\text{O}_3$ .

8 Figure 13 depicts the mean temperature distribution of the solid and fluid phases of  
 9 honeycomb structure receiver made of different materials as a function of the absorber depth  
 10 using  $u_{in} = 0.4741 \text{ m/s}$ . As mentioned before, in case of honeycomb receiver made of Alumina  
 11 (low absorptivity material) the majority of the concentrated sunlight on the frontal surface of  
 12 the receiver is reflected back to the ambient, and the photons can run away from the exit of the  
 13 receiver due to the low absorptivity of the material. Therefore, as can be seen from Fig. 13, air  
 14 outlet temperature is very low (around 690 K) in comparison with SiC and C- $\text{Al}_2\text{O}_3$ . Moreover,  
 15 the solid and fluid phases do not reach the thermal equilibrium. There is a temperature  
 16 difference between the two phases even at the exit of the receiver. This leads to unfavorable  
 17 receiver performance in terms of air outlet temperature and thermal efficiency. On the other  
 18 hand, coated alumina (C- $\text{Al}_2\text{O}_3$ ) honeycomb absorbers show favorable receiver performance in

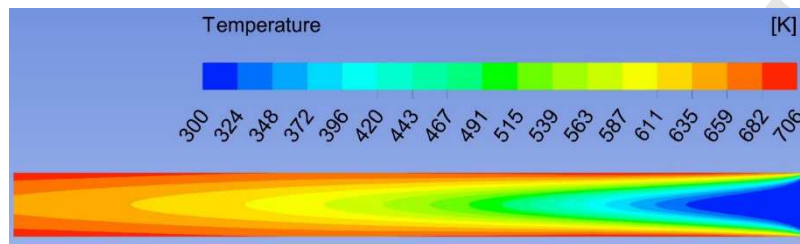
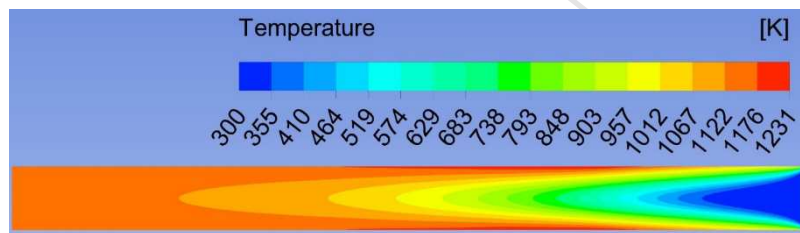

1 terms of positive volumetric effect (air outlet temperature is higher than frontal surface  
2 temperature) and relatively higher air outlet temperature as compared to SiC and Al<sub>2</sub>O<sub>3</sub>. This  
3 can be attributed to relatively higher values optical efficiency and penetration depth of the  
4 radiative heat flux. Using C-Al<sub>2</sub>O<sub>3</sub>, penetration depth values as high as three times that of SiC  
5 have been obtained.

6 Regarding SiC honeycomb absorber (high absorptivity material), the peak temperature of the  
7 solid absorber exists near the entrance of the receiver which is higher than air outlet  
8 temperature, indicating negative value of volumetric effect and high convective and radiative  
9 heat losses. As compared to C-Al<sub>2</sub>O<sub>3</sub>, the low performance of the SiC honeycomb absorber can  
10 be attributed to the absorption of the majority of the concentrated solar heat flux within the  
11 first few millimeters (10 mm of absorber channel). The resulting penetration depth is very small  
12 compared to coated alumina absorbers.

13 It should be mentioned that the solid temperature in penetration zone is governed by the  
14 thermal balance between radiative and convective losses from the frontal surface to the  
15 ambient on one side, and the convective heat transfer between the solid and fluid and heat  
16 conduction in the honeycomb absorber on the other side. For low values of penetration depth,  
17 the volumetric surface area of the honeycomb structure in the penetration zone is small. The  
18 decrease of volumetric surface area decreases the amount of convective heat removal by air.  
19 This leads to an increase in the temperature of the frontal surface and a decrease in the outlet  
20 air temperature from the receiver. Also, the increase in the frontal surface temperature is  
21 accompanied by an increase in convection and radiation losses to the ambient. Solar flux  
22 penetration inside the channel for C-Al<sub>2</sub>O<sub>3</sub> reaches about 30 mm with a peak value of 170  
23 kW/m<sup>2</sup> as compared to about 10 mm with a peak value of 480 kW/m<sup>2</sup> for SiC. It can be  
24 observed that approximately all the incident solar radiation is absorbed in the first 10 mm of  
25 SiC absorber channel depth. This leads to higher temperature at the frontal surface of the  
26 receiver, higher emission losses, lower solar-to-thermal efficiency, and lower air outlet  
27 temperature. The lower front surface temperature of C-Al<sub>2</sub>O<sub>3</sub> is a result of the distribution of  
28 solar flux on a larger surface area as due to larger penetration depth of solar radiation. This  
29 enhances the convective heat transfer between the solid and the fluid with a remarkable  
30 decrease of solid temperature at the entrance region of the channel. The above discussion  
31 clearly demonstrate the relationship between the solar flux penetration depth and the

- 1 performance of the volumetric solar receivers. Increasing the flux penetration depth has a
- 2 positive impact on the performance of VSR.

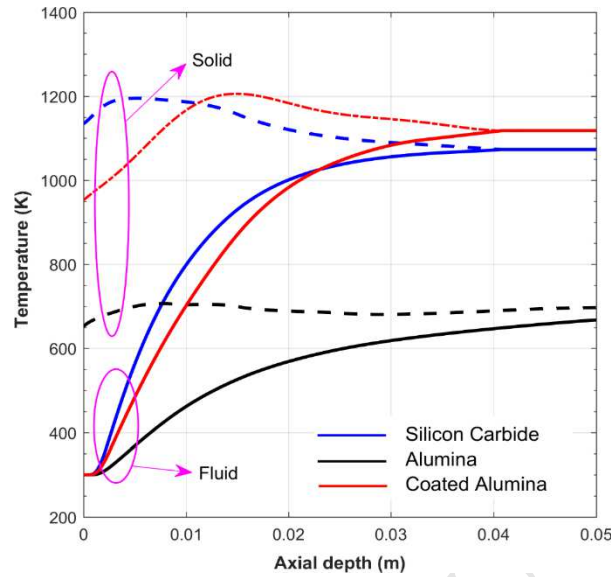

Fig.13. Temperature distribution along the centerline of a honeycomb absorber made of different materials with  $u_{in} = 0.4741$  m/s.

### 3 6.3 Evaluation of Optical and Thermal Performance of the Honeycomb Receiver

4 The effects of air flow rate on the thermal performance of the solar receiver have been  
 5 investigated by studying the variations of air outlet temperature ( $T_{air\ out}$ ), temperature of the  
 6 absorber at the entrance ( $Z = 0\ mm$ ) ( $T_{Solid\ in}$ ), and solar-to-thermal efficiency ( $\eta_{s \rightarrow Th.}$ ) as a  
 7 function of inlet velocity ( $u_{in}$ ), see Fig. 14. Overall, it has been observed that increasing the  
 8 inlet velocity of air decrease the air outlet temperature, frontal surface temperature of the  
 9 receiver and increase the solar-to-thermal efficiency. This in agreement with the findings of  
 10 Cagnoli et al. [32]. This may be attributed to the fact that the absorbed solar power ( $P_{abs}$ ) is  
 11 more or less constant since the value of the DNI and the characteristics of the solar furnace  
 12 optical model are always the same. The power to air, therefore, is almost constant (  
 13  $P_{air} = \dot{m}C_p(T_{air\ out} - T_{air\ in})$ ) thus, for a given value of air inlet temperature, increasing  $u_{in}$  (i.e.  
 14  $\dot{m}$ ) leads to a decrease in  $T_{air\ out}$ , and a decrease of the average air temperature within the  
 15 honeycomb channel. This leads to a decrease in the temperature of the internal walls of the  
 16 honeycomb channel as well as the frontal surface temperature. Moreover, decreasing the  
 17 frontal surface temperature with the increase of  $u_{in}$  leads to a reduction in the convective and

1 radiative heat losses ( $Q_{conv.}$  and  $Q_{rad.}$ ) to the ambient. Therefore, it can be seen that the solar-  
2 to-thermal efficiency of the receiver ( $\eta_{s \rightarrow Th.}$ ) increases with the increase of  $u_{in}$ .

3 For the range of  $u_{in}$  studied, both air outlet temperature and solar-to-thermal efficiency of  
4 C-Al<sub>2</sub>O<sub>3</sub> honeycomb absorber proposed in the present work are higher than those of SiC and  
5 Al<sub>2</sub>O<sub>3</sub> absorbers. This can be attributed as due to the higher penetration depth of the solar heat  
6 flux and the lower convective and radiative heat losses from the frontal surface. This  
7 performance is advantageous when one considers the low cost and high-temperature oxidation  
8 resistance of Al<sub>2</sub>O<sub>3</sub> as compared to conventional SiC honeycomb absorbers. In a first evaluation  
9 of the effectiveness of the current proposed method, the authors suggested applying high  
10 absorptivity coating at the surface of exit half of absorber channel made of low absorptivity  
11 material (Al<sub>2</sub>O<sub>3</sub>). The results show an increase in the optical efficiency, penetration depth of  
12 absorber heat flux, positive volumetric effect, and high solar to thermal efficiency. Based on the  
13 present analysis, the authors believe that the suggested location of coated section should be  
14 always applied away from the channel entrance. Further parametric analysis for the  
15 optimization of this coated length shall be carried in the future.

16 In previous studies [30], the effects of radiative exchange between the inner walls of the  
17 honeycomb channel have been neglected. Figure 15 shows the impact of radiative emission on  
18 the solar to thermal efficiency of honeycomb structure receiver made of different materials.  
19 Overall, it has been observed that neglecting the radiative exchange will lead to overestimation  
20 of solar to thermal efficiency. The difference between  $\eta_{s \rightarrow Th.}$  predicted with and without  
21 considering the radiative exchange is significant especially at lower values of  $u_{in}$ . This can be  
22 attributed to the increase of the penetration zone temperature (see Fig. 14b) and emission  
23 losses with the decrease of  $u_{in}$ .

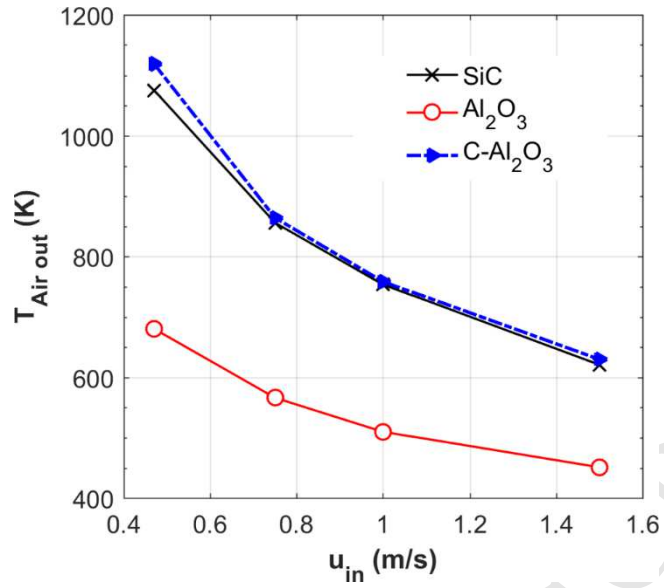

(a) Air outlet temperature

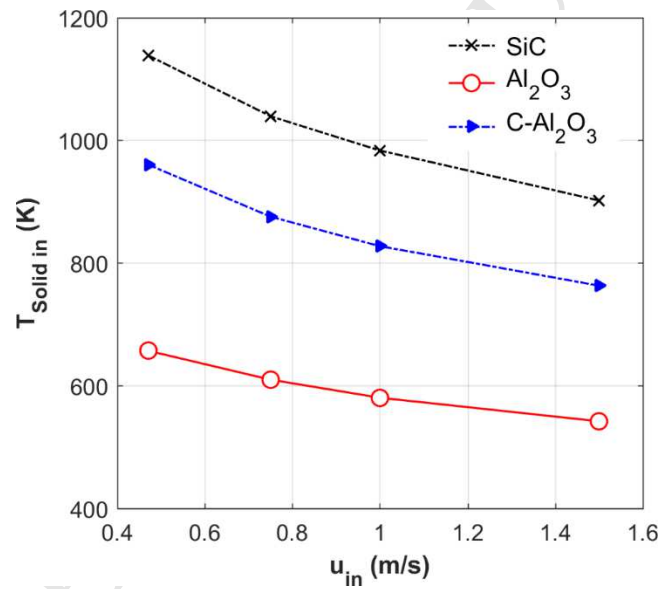

(b) Absorber frontal surface temperature

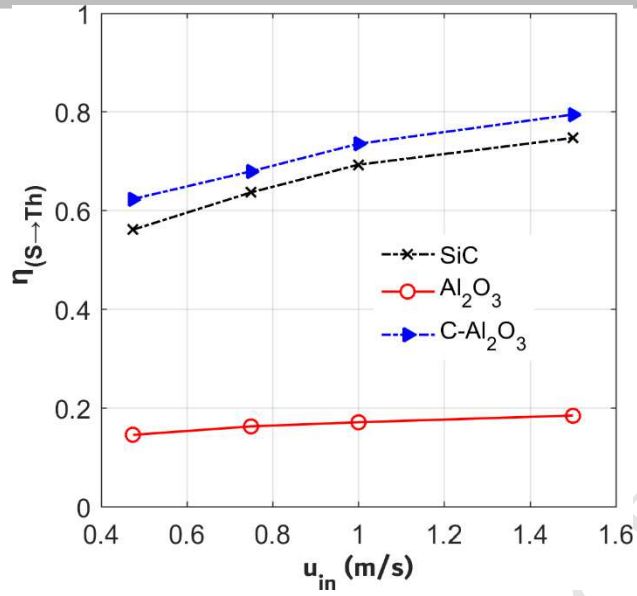

(c) Solar-to-thermal efficiency

Fig.14. Variation of: (A) air outlet temperature; (B) temperature of the absorber at the entrance; (C) solar-to-thermal efficiency with inlet velocity.

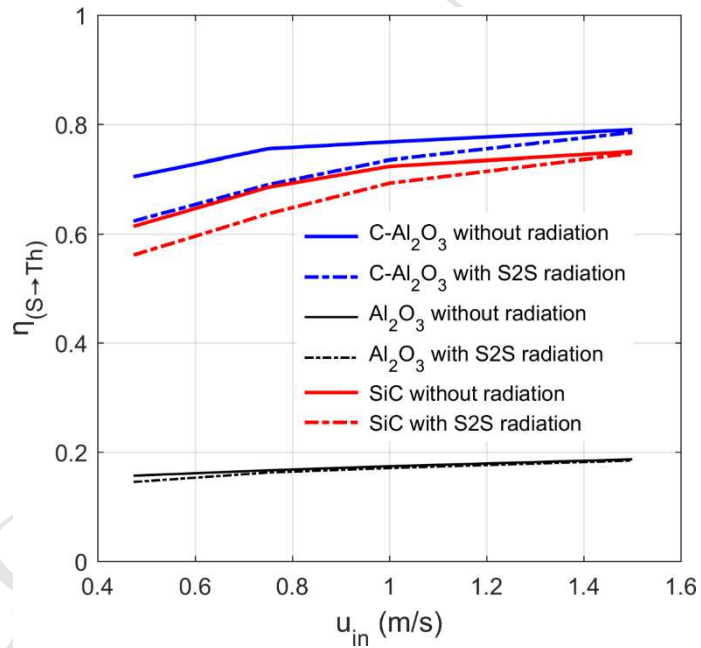

Fig. 15. Impact of radiative emission on the solar to thermal efficiency of honeycomb structure receiver made of different materials.

## 1 7. Conclusions

2 Coupled, consistent, 3D, optical, heat transfer and fluid flow numerical models have been  
3 developed for the analysis and design of honeycomb volumetric solar receiver modules. The  
4 current models employ realistic physical and solution domains. They have been used to analyze  
5 the performance of solar receiver modules using Silicon Carbide and Alumina representing solar  
6 absorbers of high and low absorptivity, respectively.

7 The absorptivity of the material significantly affects the optical and thermal performance of  
8 the receiver. Positive volumetric effect and high solar-to-thermal-efficiency can be obtained by  
9 controlling the absorbed radiation heat flux distribution within the honeycomb receiver using  
10 judicious surface coating of the absorber material. A novel honeycomb receiver made of  
11 Alumina has been introduced by using judicious surface coating of the absorber material. The  
12 coating has been designed with the objective of reducing the reflection losses from the frontal  
13 surface and increasing the penetration depth of the solar flux inside the honeycomb receiver  
14 channel. The new introduced coated Alumina honeycomb absorbers show a favorable receiver  
15 performance in terms of air outlet temperature and solar-to-thermal efficiency compared to  
16 conventional SiC honeycomb absorbers.

17 Alumina is a low cost well-balanced material featuring high wear resistance, high mechanical  
18 strength, and thermal stability. In addition, as compared to SiC, Alumina has high oxidation  
19 resistance at high temperature. The low performance of the SiC honeycomb absorber can be  
20 attributed to that the majority of the concentrated solar heat flux is absorbed within the first  
21 few millimeters (10 mm) and the penetration depth is very small compared to coated Alumina  
22 absorbers. For the range of air flow velocity studied, the solar-to-thermal efficiency increases  
23 with the increase of air mass flow rate. However, this is accompanied by a decrease in the air  
24 outlet temperature and frontal surface temperature. The decrease in air outlet temperature  
25 may have a negative effect on the thermal efficiency of the power block connected to the solar  
26 receiver.

1 **References**

- 2 [1] O. Behar, A. Khellaf, K. Mohammedi, A review of studies on central receiver solar thermal  
3 power plants, *Renewable and Sustainable Energy Reviews*. 23 (2013) 12–39.  
4 doi:10.1016/j.rser.2013.02.017.
- 5 [2] J. Blanco, S. Malato, P. Fernández-Ibañez, D. Alarcón, W. Gernjak, M. Maldonado, Review  
6 of feasible solar energy applications to water processes, *Renewable and Sustainable*  
7 *Energy Reviews*. 13 (2009) 1437–1445. doi:10.1016/j.rser.2008.08.016.
- 8 [3] J.M. Gordon, K.C. Ng, High-efficiency solar cooling, *Solar Energy*. 68 (2000) 23–31.  
9 doi:10.1016/S0038-092X(99)00053-5.
- 10 [4] T. Nakamura, Hydrogen production from water utilizing solar heat at high temperatures,  
11 *Solar Energy*. 19 (1977) 467–475. doi:10.1016/0038-092X(77)90102-5.
- 12 [5] D. Barlev, R. Vidu, P. Stroeve, Innovation in concentrated solar power, *Solar Energy*  
13 *Materials and Solar Cells*. 95 (2011) 2703–2725. doi:10.1016/j.solmat.2011.05.020.
- 14 [6] C.K. Ho, B.D. Iverson, Review of high-temperature central receiver designs for  
15 concentrating solar power, *Renewable and Sustainable Energy Reviews*. 29 (2014) 835–  
16 846. doi:10.1016/j.rser.2013.08.099.
- 17 [7] A.L. Avila-Marin, Volumetric receivers in solar thermal power plants with central receiver  
18 system technology: a review, *Solar Energy*. 85 (2011) 891–910.  
19 doi:10.1016/j.solener.2011.02.002.
- 20 [8] A. Kribus, Y. Gray, M. Grijnevich, G. Mittelman, S. Mey-Cloutier, C. Caliot, The promise and  
21 challenge of solar volumetric absorbers, *Solar Energy*. 110 (2014) 463–481.  
22 doi:10.1016/j.solener.2014.09.035.
- 23 [9] M. Romero, R. Buck, J.E. Pacheco, An update on solar central receiver systems, projects,  
24 and technologies, *Journal of Solar Energy Engineering*. 124 (2002) 98–108.  
25 doi:10.1115/1.1467921.
- 26 [10] H. Fricker, Proposal for a novel type of solar gas receiver, in: *Proceedings of the*  
27 *International Seminar on Solar Thermal Heat Production*, Stuttgart, German Aerospace  
28 Center (DLR), Pfaffenwaldring, 1983: pp. 38–40.
- 29 [11] P. Heinrich, G. Keintzel, C. Streuber, Technology Program Solar Air Receiver—2.5 MWt  
30 System Test on Volumetric Air Receiver Technology, in: *Proceedings of the 6th*  
31 *International Symposium on Solar Thermal Concentrating Technologies*, 1992: pp. 247–  
32 261.
- 33 [12] T. Hellmuth, L. Matthews, J. Chavez, C. Hale, Performance of a wire mesh solar volumetric  
34 air receiver, *Solar Engineering*. (1994) 573–573.
- 35 [13] R. Pitz-Paal, Evaluation of the CATREC II Receiver Test, *SolarPACES Technical Report*.  
36 (1996).
- 37 [14] T. Hellmuth, L. Matthews, Modeling and optimum design of a wire mesh solar volumetric  
38 air receiver, *Journal of Solar Energy Engineering*. 119 (1997) 208–213.  
39 doi:10.1115/1.2888020.
- 40 [15] F. Tellez, M. Romero, M. Marcos, Design of "SIREC-1" Wire Mesh Open Volumetric Solar  
41 Receiver Prototype, *Solar Engineering*. (2001) 357–364.
- 42 [16] J.M. Chavez, C. Chaza, Testing of a porous ceramic absorber for a volumetric air receiver,  
43 *Solar Energy Materials*. 24 (1991) 172–181. doi:10.1016/0165-1633(91)90057-R.
- 44 [17] R. Pitz-Paal, J. Morhenne, M. Fiebig, A new concept of a selective solar receiver for high  
45 temperature applications, *Solar Energy Materials*. 24 (1991) 293–306. doi:10.1016/0165-  
46 1633(91)90070-2.

- 1 [18] F. Reale, G. Ruocco, A. Carotenuto, U. Nocera, F. Bonomo, Final design of a multi cavity  
2 volumetric solar receiver, *Solar Energy Materials*. 24 (1991) 284–292. doi:10.1016/0165-  
3 1633(91)90069-W.
- 4 [19] B. Hoffschmidt, The development strategy of the HiTREC volumetric receiver technology  
5 up scaling from 200 kW h via 3 MW h up to 10 MWel, *Proceedings of the 11th SolarPACES*  
6 *International Symposium on Concentrated Solar Power and Chemical Energy*,  
7 *Technologies*, Zurich, Switzerland. (2002).
- 8 [20] B. Hoffschmidt, F.M. Téllez, A. Valverde, J. Fernández, V. Fernández, Performance  
9 evaluation of the 200-kWth HiTREC-II open volumetric air receiver, *Journal of Solar Energy*  
10 *Engineering*. 125 (2003) 87–94. doi:10.1115/1.1530627.
- 11 [21] B. Hoffschmidt, G. Dibowski, M. Beuter, V. Fernandez, F. Téllez, P. Stobbe, Test results of a  
12 3 MW solar open volumetric receiver, (2003).
- 13 [22] F. Tellez, M. Romero, P. Heller, A. Valverde, G. Dibowski, S. Ulmer, Thermal performance  
14 of SolAir 3000 kWth ceramic volumetric solar receiver, in: *12th International Symposium*  
15 *Solar Power and Chemical Energy Systems*, October 6-8, 2004, Oaxaca, Mexico, Instituto de  
16 *Investigaciones Electricas*, 2004.
- 17 [23] Z. Wu, C. Caliot, G. Flamant, Z. Wang, Coupled radiation and flow modeling in ceramic  
18 foam volumetric solar air receivers, *Solar Energy*. 85 (2011) 2374–2385.  
19 doi:10.1016/j.solener.2011.06.030.
- 20 [24] S. Mey-Cloutier, C. Caliot, A. Kribus, Y. Gray, G. Flamant, Experimental study of ceramic  
21 foams used as high temperature volumetric solar absorber, *Solar Energy*. 136 (2016) 226–  
22 235. doi:10.1016/j.solener.2016.06.066.
- 23 [25] F. Zaversky, L. Aldaz, M. Sánchez, A.L. Ávila-Marín, M.I. Roldán, J. Fernández-Reche, A.  
24 Füssel, W. Beckert, J. Adler, Numerical and experimental evaluation and optimization of  
25 ceramic foam as solar absorber—Single-layer vs multi-layer configurations, *Applied Energy*.  
26 210 (2018) 351–375. doi:10.1016/j.apenergy.2017.11.003.
- 27 [26] F. Wang, Y. Shuai, H. Tan, C. Yu, Thermal performance analysis of porous media receiver  
28 with concentrated solar irradiation, *International Journal of Heat and Mass Transfer*. 62  
29 (2013) 247–254. doi:10.1016/j.ijheatmasstransfer.2013.03.003.
- 30 [27] M. Alaa, M. Rady, M. Attia, E. Ewais, Optical study of using ceramic foams for volumetric  
31 solar receivers, in: *Renewable and Sustainable Energy Conference (IRSEC)*, 2016  
32 *International*, IEEE, 2016: pp. 284–289. doi:10.1109/IRSEC.2016.7983917.
- 33 [28] R. Capuano, T. Fend, H. Stadler, B. Hoffschmidt, R. Pitz-Paal, Optimized volumetric solar  
34 receiver: Thermal performance prediction and experimental validation, *Renewable*  
35 *Energy*. 114 (2017) 556–566. doi:10.1016/j.renene.2017.07.071.
- 36 [29] H.-J. Lee, J.-K. Kim, S.-N. Lee, Y.-H. Kang, Consistent heat transfer analysis for performance  
37 evaluation of multichannel solar absorbers, *Solar Energy*. 86 (2012) 1576–1585.  
38 doi:10.1016/j.solener.2012.02.020.
- 39 [30] T. Fend, P. Schwarzbözl, O. Smirnova, D. Schöllgen, C. Jakob, Numerical investigation of  
40 flow and heat transfer in a volumetric solar receiver, *Renewable Energy*. 60 (2013) 655–  
41 661. doi:10.1016/j.renene.2013.06.001.
- 42 [31] M. Sanchez, M. Marcos, M. Romero, C. Estrada, Design Parameters Influence on Flux  
43 Distribution Through Prismatic Channels of Volumetric Absorbers, in: *EuroSun2004*,  
44 *Conference Proceedings*, 2004: pp. 953–962.
- 45 [32] M. Cagnoli, L. Savoldi, R. Zanino, F. Zaversky, Coupled optical and CFD parametric analysis  
46 of an open volumetric air receiver of honeycomb type for central tower CSP plants, *Solar*  
47 *Energy*. 155 (2017) 523–536. doi:10.1016/j.solener.2017.06.038.



- 1 [33] B. Yilbas, S. Shuja, A Solar Volumetric Receiver: Influence of Absorbing Cells Configuration  
2 on Device Thermal Performance, *International Journal of Thermophysics*. 38 (2017) 1.  
3 doi:10.1007/s10765-016-2132-3.
- 4 [34] O. Smirnova, T. Fend, R. Capuano, G. Feckler, P. Schwarzbözl, F. Sutter, Determination of  
5 critical thermal loads in ceramic high concentration solar receivers, *Solar Energy Materials*  
6 *and Solar Cells*. 176 (2018) 196–203. doi:10.1016/j.solmat.2017.11.033.
- 7 [35] R. Capuano, T. Fend, P. Schwarzbözl, O. Smirnova, H. Stadler, B. Hoffschmidt, R. Pitz-Paal,  
8 Numerical models of advanced ceramic absorbers for volumetric solar receivers,  
9 *Renewable and Sustainable Energy Reviews*. 58 (2016) 656–665.  
10 doi:10.1016/j.rser.2015.12.068.
- 11 [36] F. Gomez-Garcia, J. Gonzalez-Aguilar, S. Tamayo-Pacheco, G. Olalde, M. Romero,  
12 Numerical analysis of radiation propagation in a multi-layer volumetric solar absorber  
13 composed of a stack of square grids, *Solar Energy*. 121 (2015) 94–102.  
14 doi:10.1016/j.solener.2015.04.047.
- 15 [37] A. Kasaeian, H. Barghamadi, F. Pourfayaz, Performance comparison between the geometry  
16 models of multi-channel absorbers in solar volumetric receivers, *Renewable Energy*. 105  
17 (2017) 1–12. doi:10.1016/j.renene.2016.12.038.
- 18 [38] G. Levêque, R. Bader, W. Lipiński, S. Haussener, High-flux optical systems for solar  
19 thermochemistry, *Solar Energy*. (2017). doi:10.1016/j.solener.2017.07.046.
- 20 [39] M.J. Blanco, J.M. Amieva, A. Mancillas, The Tonatiuh Software Development Project: An  
21 open source approach to the simulation of solar concentrating systems, in: *ASME 2005*  
22 *International Mechanical Engineering Congress and Exposition*, American Society of  
23 *Mechanical Engineers*, 2005: pp. 157–164. doi:10.1115/IMECE2005-81859.
- 24 [40] M. Blanco, A. Mutuberria, D. Martinez, Experimental validation of Tonatiuh using the  
25 *Plataforma Solar de Almería secondary concentrator test campaign data*, in: *16th Annual*  
26 *SolarPACES Symposium*, 2010.
- 27 [41] A. Mutuberria, A. Monreal, A. Albert, M. Blanco, Results of the empirical validation of  
28 Tonatiuh at Mini-Pegase CNRS-PROMES facility, in: *Proceedings of the 17th SolarPACES*  
29 *Int. Symposium on Concentrating Solar Power and Chemical Energy*, 2011.
- 30 [42] R.H. Pletcher, J.C. Tannehill, D. Anderson, *Computational fluid mechanics and heat*  
31 *transfer*, CRC Press, 2012.
- 32 [43] S. Patankar, *Numerical heat transfer and fluid flow*, CRC press, 1980.
- 33 [44] A. Fluent, *ANSYS fluent theory guide 15.0*, ANSYS, Canonsburg, PA. (2013).
- 34 [45] T. Fend, O. Reutter, J. Bauer, B. Hoffschmidt, Two novel high-porosity materials as  
35 volumetric receivers for concentrated solar radiation, *Solar Energy Materials and Solar*  
36 *Cells*. 84 (2004) 291–304. doi:10.1016/j.solmat.2004.01.039.
- 37 [46] C.C. Agrafiotis, I. Mavroidis, A.G. Konstandopoulos, B. Hoffschmidt, P. Stobbe, M. Romero,  
38 V. Fernandez-Quero, Evaluation of porous silicon carbide monolithic honeycombs as  
39 volumetric receivers/collectors of concentrated solar radiation, *Solar Energy Materials and*  
40 *Solar Cells*. 91 (2007) 474–488. doi:10.1016/j.solmat.2006.10.021.
- 41 [47] D. Sciti, L. Silvestroni, L. Mercatelli, J.-L. Sans, E. Sani, Suitability of ultra-refractory diboride  
42 ceramics as absorbers for solar energy applications, *Solar Energy Materials and Solar Cells*.  
43 109 (2013) 8–16. doi:10.1016/j.solmat.2012.10.004.
- 44 [48] D. Sciti, L. Silvestroni, J.-L. Sans, L. Mercatelli, M. Meucci, E. Sani, Tantalum diboride-based  
45 ceramics for bulk solar absorbers, *Solar Energy Materials and Solar Cells*. 130 (2014) 208–  
46 216. doi:10.1016/j.solmat.2014.07.012.

- 1 [49] E. Sani, L. Mercatelli, J.-L. Sans, D. Sciti, Optical properties of black and white ZrO<sub>2</sub> for solar  
2 receiver applications, *Solar Energy Materials and Solar Cells*. 140 (2015) 477–482.  
3 doi:10.1016/j.solmat.2015.02.007.
- 4 [50] Y. Kim, A. Zangvil, J.S. Goela, R.L. Taylor, Microstructure comparison of transparent and  
5 opaque CVD SiC, *Journal of the American Ceramic Society*. 78 (1995) 1571–1579.  
6 doi:10.1111/j.1151-2916.1995.tb08853.x.
- 7 [51] B.-N. Kim, K. Hiraga, K. Morita, H. Yoshida, T. Miyazaki, Y. Kagawa, Microstructure and  
8 optical properties of transparent alumina, *Acta Materialia*. 57 (2009) 1319–1326.
- 9 [52] R. Munro, Material properties of a sintered  $\alpha$ -SiC, *Journal of Physical and Chemical*  
10 *Reference Data*. 26 (1997) 1195–1203. doi:10.1063/1.556000.
- 11 [53] P. Auerkari, Mechanical and physical properties of engineering alumina ceramics,  
12 Technical Research Centre of Finland Espoo, 1996.
- 13 [54] T.K. Papathanasiou, F. Dal Corso, A. Piccolroaz, Thermo-mechanical response FEM  
14 simulation of ceramic refractories undergoing severe temperature variations, *Journal of*  
15 *the European Ceramic Society*. 36 (2016) 2329–2340.  
16 doi:10.1016/j.jeurceramsoc.2016.01.022.
- 17 [55] W. Sutherland, LII. The viscosity of gases and molecular force, *The London, Edinburgh, and*  
18 *Dublin Philosophical Magazine and Journal of Science*. 36 (1893) 507–531.  
19 doi:10.1080/14786449308620508.
- 20 [56] G. Barreto, P. Canhoto, M. Collares-Pereira, Three-dimensional modelling and analysis of  
21 solar radiation absorption in porous volumetric receivers, *Applied Energy*. 215 (2018) 602–  
22 614. doi:10.1016/j.apenergy.2018.02.065.
- 23 [57] X. Chen, F. Wang, X. Yan, Z. Cheng, Y. Han, Z. Jie, Thermal and chemical analysis of  
24 methane dry reforming in a volumetric reactor under highly concentrated solar radiation,  
25 *Solar Energy*. 162 (2018) 187–195. doi:10.1016/j.solener.2018.01.032.
- 26 [58] M. Nakakura, K. Matsubara, S. Bellan, T. Kodama, Efficiency and heat loss analysis of  
27 honeycomb receiver varying air mass flow rate and beam width, *International Journal of*  
28 *Heat and Mass Transfer*. 137 (2019) 1027–1040.  
29 doi:10.1016/j.ijheatmasstransfer.2019.03.153.
- 30 [59] M. Nakakura, S. Bellan, K. Matsubara, T. Kodama, Conjugate radiation-convection-  
31 conduction simulation of volumetric solar receivers with cut-back inlets, *Solar Energy*. 170  
32 (2018) 606–617. doi:10.1016/j.solener.2018.06.006.
- 33 [60] C.K. Ho, A.R. Mahoney, A. Ambrosini, M. Bencomo, A. Hall, T.N. Lambert, Characterization  
34 of Pyromark 2500 paint for high-temperature solar receivers, *Journal of Solar Energy*  
35 *Engineering*. 136 (2014) 014502. doi:10.1115/1.4024031.
- 36 [61] M.H. Gray, R. Tirawat, K.A. Kessinger, P.F. Ndione, High temperature performance of high-  
37 efficiency, multi-layer solar selective coatings for tower applications, *Energy Procedia*. 69  
38 (2015) 398–404. doi:10.1016/j.egypro.2015.03.046.
- 39

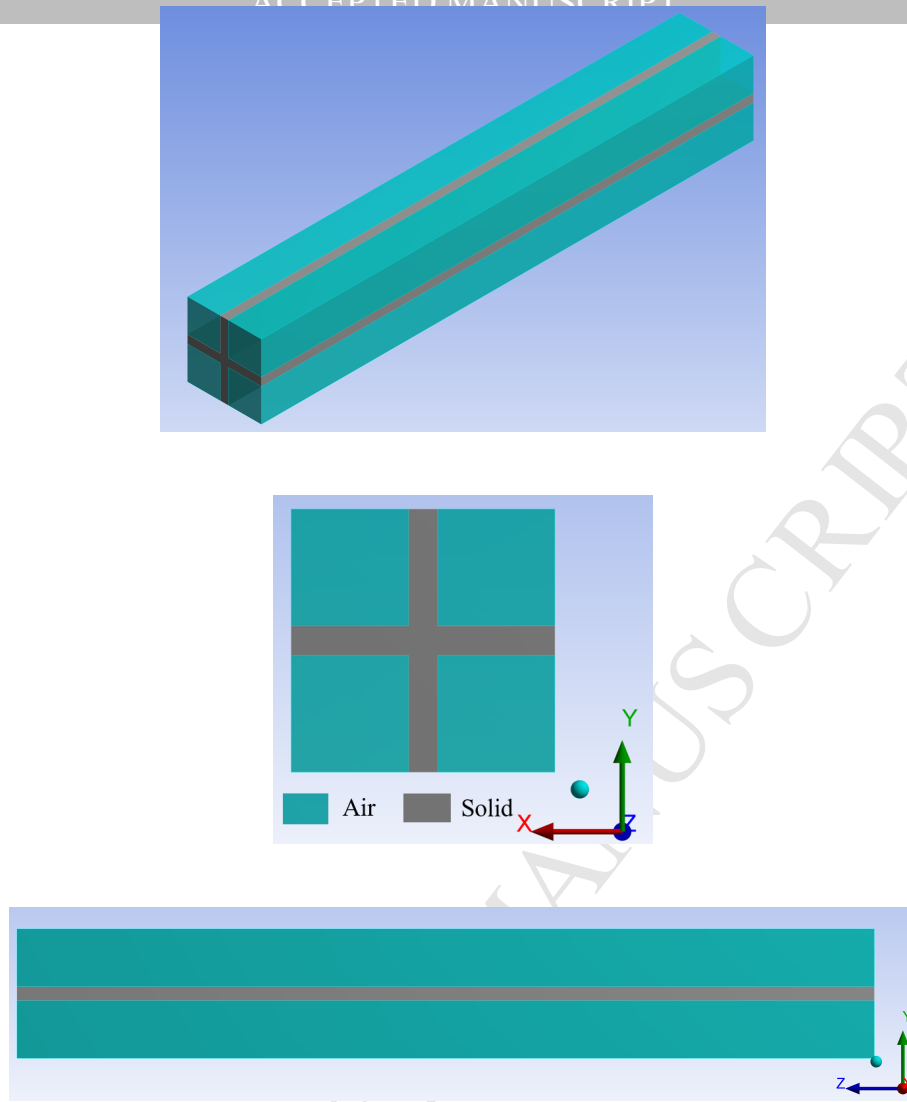

Figure 1: CFD solution domain

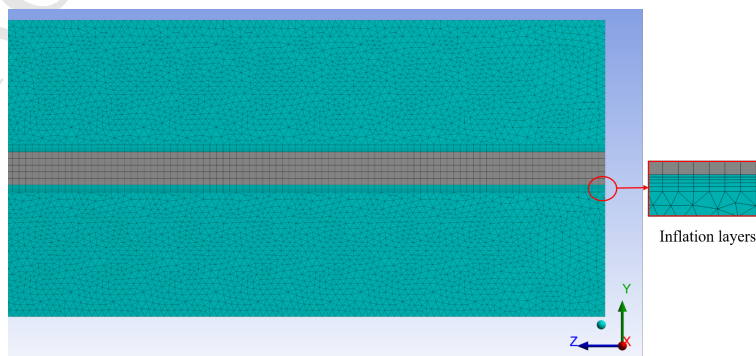
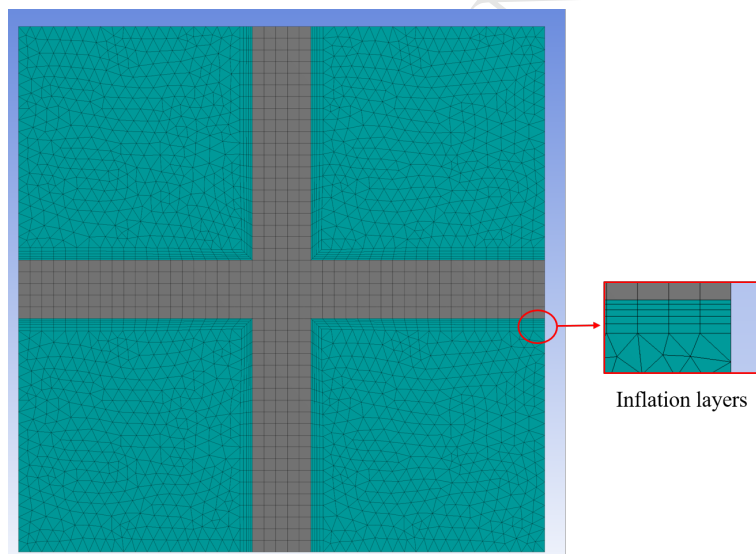
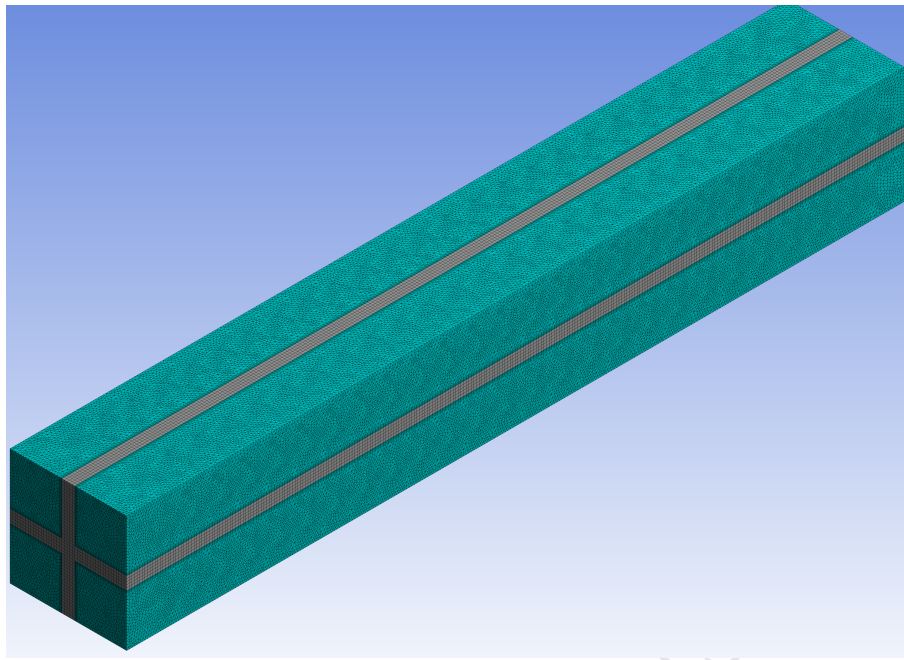

Figure 2: Numerical solution domain with generated mesh

- Optical, CFD models for the analysis and design of volumetric solar receivers.
- Effects of absorber material and air flow rate on the performance are analyzed.
- A novel honeycomb receiver made of Alumina has been introduced.
- Coated alumina honeycomb absorbers show a favorable receiver performance.

ACCEPTED MANUSCRIPT