



HAL
open science

Impact of occupant's actions on energy building performance and thermal sensation

Mathieu Bonte, Françoise Thellier, Bérangère Lartigue

► **To cite this version:**

Mathieu Bonte, Françoise Thellier, Bérangère Lartigue. Impact of occupant's actions on energy building performance and thermal sensation. *Energy and Buildings*, 2014, 76, pp.219-227. 10.1016/j.enbuild.2014.02.068 . hal-02175269

HAL Id: hal-02175269

<https://hal.science/hal-02175269>

Submitted on 8 Jul 2019

HAL is a multi-disciplinary open access archive for the deposit and dissemination of scientific research documents, whether they are published or not. The documents may come from teaching and research institutions in France or abroad, or from public or private research centers.

L'archive ouverte pluridisciplinaire **HAL**, est destinée au dépôt et à la diffusion de documents scientifiques de niveau recherche, publiés ou non, émanant des établissements d'enseignement et de recherche français ou étrangers, des laboratoires publics ou privés.

Elsevier Editorial System(tm) for Energy and Buildings
Manuscript Draft

Manuscript Number: ENB-D-13-01162

Title: Impact of occupant's actions on energy building performance and thermal sensation

Article Type: Full Length Article

Keywords: occupant's behavior; building simulation; human thermal sensation; energy demand; design of experiment

Corresponding Author: Mr. Mathieu Bonte,

Corresponding Author's Institution: Universite Toulouse III - Paul Sabatier - Laboratoire PHASE - Toulouse, France

First Author: Mathieu Bonte

Order of Authors: Mathieu Bonte; Francoise Thellier; Berangere Lartigue

Abstract: In this study, the impact of behavioral actions of a building occupant on energy performance and thermal sensation are investigated. The study focuses on the six following actions: use of blinds, lighting system, windows, fan, thermostat and clothing adjustments. Eight types of buildings, classified among three criteria (air-conditioning, thermal inertia and climate), are studied. Simulation of the occupant's actions, building performance and thermal sensation have been carried out by using TRNSYS 17.

Impact on energy demand and thermal sensation of each action has been investigated with a Design Of Experiments methodology coupled with the use of Yate's algorithm. This study shows that for a given building, the occupant's actions have a significant impact on energy demand. Building simulation in literature typically does not model human activity in energy consumption, yet our study demonstrate a strong correlation.

Results from the design of experiments methodology are compared to conventional French design strategy. It appears that conventional French design strategy, which does not take into account occupants' actions, tends to strongly underestimate building energy demand.

Suggested Reviewers: Radu Zmeureanu
radu.zmeureanu@concordia.ca

Laurent ZALEWSKI
laurent.zalewski@univ-artois.fr

Da YAN
yanda@tsinghua.edu.cn



September 10, 2013

Dear Editor,

Please find enclosed our article entitled "Impact of occupant's actions on energy building performance and thermal sensation" that we would like to submit to Energy and Buildings.

No part of the manuscript has been published in any other form and is intended for publication elsewhere.

I remain at your disposal for any comment.

Best regards,

Mathieu Bonte

mathieu.bonte@univ-tlse3.fr

1
2
3
4
5
6
7
8
9
10
11
12
13
14
15
16
17
18
19
20
21
22
23
24
25
26
27
28
29
30
31
32
33
34
35
36
37
38
39
40
41
42
43
44
45
46
47
48
49
50
51
52
53
54
55
56
57
58
59
60
61
62
63
64
65

Impact of occupant's actions on energy building performance and thermal sensation

Mathieu Bonte, Francoise Thellier*, Berangere Lartigue

*Universite Toulouse III - Paul Sabatier, Laboratoire PHASE, 118 route de Narbonne, 31062
Toulouse, France*

Abstract

In this study, the impact of behavioral actions of a building occupant on energy performance and thermal sensation are investigated. The study focuses on the six following actions: use of blinds, lighting system, windows, fan, thermostat and clothing adjustments. Eight types of buildings, classified among three criteria (air-conditioning, thermal inertia and climate), are studied. Simulation of the occupant's actions, building performance and thermal sensation have been carried out by using TRNSYS 17.

Impact on energy demand and thermal sensation of each action has been investigated with a Design Of Experiments methodology coupled with the use of Yate's algorithm. This study shows that for a given building, the occupant's actions have a significant impact on energy demand. Building simulation in literature typically does not model human activity in energy consumption, yet our study demonstrate a strong correlation.

Results from the design of experiments methodology are compared to conventional French design strategy. It appears that conventional French design strategy, which does not take into account occupants' actions, tends to strongly underestimate building energy demand.

Keywords: occupant's behavior, building simulation, human thermal

*Corresponding author

Email address: francoise.thellier@univ-tlse3.fr (Francoise Thellier)

Nomenclature

Latin letters

a	Estimated factor effects
EF	Error Factor
\overline{ME}	Mean Main Effect
n	number of factors
Q	Energy demand (kWh/m ² .yr)
r	number of responses
R	Mean of a response from design of experiment
$RMME$	Relative Mean Main Effect
RSD	Relative Relative Standard Deviation
SGT	Positive thermal sensation indicator
SLT	Negative thermal sensation indicator
ST	Thermal sensation
t	Time (h)
U	Thermal transfer coefficient (W/m ² .K)
X	Factor of experiments
Y	Response of experiments

Greek symbols

μ	Mean
σ	Standard deviation

Subscripts

$cool$	Cooling
$heat$	Heating
$light$	Lighting
D	Results from DOE
tot	Total
C	Results from conventional French design strategy

1
2
3
4
5
6
7
8
9 **1. Introduction**

10 Field surveys have shown the impact of occupant presence and behavior on
11 building energy consumption.
12

13 Human behavior is mainly based on two groups of actions. The first consists of
14 universal reactions that are ingrained in human nature. The second group con-
15 sists of actions that are conditioned by personal background and experiences.
16 Thus, they could be very different depending on the individual.
17

18 Actions influencing energy building performance are part of the second group.
19 Indeed, subjected to the same environmental conditions in buildings, occupants
20 will react differently according to their personal characteristics. Those indi-
21 vidual differences could lead to large discrepancies between buildings energy
22 performances depending on how people interact with their environment. Such
23 differences have been shown since the 1970's thanks to Princeton's experiments
24 at Twin Rivers on 248 dwellings [1]. Based on these experiments, Sonderegger
25 [2] found that 71% of energy demand variation was due to occupants. Recently,
26 Maier et al. [3] investigated 22 identical houses over 2 years. Their results
27 showed differences between houses equipped with the same ventilation systems.
28 They found a discrepancy in heating consumption of a factor of two between
29 the least and the most energy efficient house of the investigated set. Since the
30 houses were identical, the discrepancy were due to occupants' behavior.
31

32 Energy related occupants actions depends on their comfort, and particularly,
33 on their thermal comfort. That is why thermal comfort has to be investigated
34 when occupants behavior is studied.
35
36
37
38
39
40

41 Since human psychology is a complex process, researchers employed statisti-
42 cal analysis of field study data. The experimental methodology (duration,
43 quantity of data etc.) varies from one study to another, but the purpose re-
44 mains the same: finding the drivers of these actions. Many field studies have
45 highlighted which drivers take part in different actions processes such as blind
46 operations [4–6] lighting systems controls [7–10], temperature regulation [11],
47
48
49
50
51
52
53
54
55
56
57
58

1
2
3
4
5
6
7
8
9 window operation [12], use of fans [13], and clothing adjustments [14]. Oc-
10 cupancy has also been investigated [15–17] since the occupant’s presence is a
11 necessary condition for an action to occur.
12
13

14
15 During the previous decades, researchers have focused on the development of
16 physical models in building simulation. Thus, many physical phenomena such as
17 heat transfers through walls, solar radiation through windows, thermal bridges,
18 and fluid dynamics have been modeled. However, and despite the accuracy
19 of these models, many studies have shown that the actual energy consumption
20 may differ substantially from the modeled energy use [18–20]. Several sources of
21 physical uncertainties are identified such as infiltration rate, thermal properties
22 of walls, internal loads, etc. [21]. However, a more significant source of uncer-
23 tainty is the occupants behavior. Indeed, Clevenger and Haymaker [22] show
24 that the occupant might be responsible for a difference of over 150% among
25 simulation results depending on assumptions about occupant behavior.
26
27

28 Current design tools model occupants in a passive way. In these simulations,
29 occupants do not really act on their environment, they are taken into account
30 according to static schedules. For example, the lights are switched on from 8 am
31 to 7 pm. Hoes et al. [23] state that current numerical tools, intended for energy
32 performance design, are inadequate for buildings where occupants have a close
33 interaction with their environment. Two years later, Mahdavi [15] showed that
34 models of occupants presence and behaviors remain too simplistic.
35
36

37 Therefore, in order to increase the accuracy of building performance tools, re-
38 searchers have recently begun creating models of human behavior in buildings.
39 Different actions have been modeled for specific cases such as blinds use [24],
40 artificial light [25], temperature regulation and clothing adjustments [26–28] or
41 interactions with windows [29].
42
43

44 Physical models for building simulation are nowadays accurate, but discrep-
45 ancies between actual and modeled energy use has been observed over the past
46 decade with the advent of energy efficient buildings [30]. Occupant behavior
47
48
49
50
51
52

1
2
3
4
5
6
7
8
9 has been recently identified as the main cause of discrepancy but its underlying
10 causes are not yet well known. Indeed, only very recent studies [31] measure
11 the individual impact of various occupants actions on energy use.
12
13
14

15 The problem of quantifying the impact of variables on systems outputs is
16 widespread and well-known. Originally, this problem has been motivated by
17 applications in agriculture [32]. The principle lies on the variation of input vari-
18 ables and their impact on system's outputs in order to find the most significant
19 variables.
20
21
22

23 This practice has lead to the birth of a full-fledged statistical field called Design
24 Of Experiments (DOE) with pioneering studies of Fisher [33] and Yates [34].
25 This methodology has been adopted in the 1950s by the chemical industry in
26 order to improve industrial processes. More recently, DOE has become popular
27 in computer science and in particular in metamodeling and optimization prob-
28 lems [35]. The reason for such popularity in computer experiments comes from
29 the low-computational time and power requirements of DOE methods which
30 limit the combinatorial explosion. Indeed, some methods evaluate the influence
31 of variables on system's outputs with a very limited number of experiments.
32
33
34
35
36
37
38

39 In this paper we investigate six occupants actions, and we estimate their
40 impact on thermal sensation and energy building performance.
41 The six following actions have been considered as influencing energy demand
42 and human thermal comfort:
43
44

- 45 • blind operations,
- 46
- 47 • lighting operations,
- 48
- 49 • windows operations,
- 50
- 51 • set point temperature regulation,
- 52
- 53 • fans operations,
- 54
- 55
- 56
- 57
- 58

- clothing adjustments.

In order to quantify the impact of each action cited above, we propose a Design Of Experiments method called "factorial experiment" based on Yates' algorithm [34].

2. Building-occupant system modeling

Modeling has been performed with the energy building simulation software TRNSYS 17 [36]. A relevant number of case studies has been investigated with the aim of comparing the occupant's influence on different types of office buildings.

2.1. Building model

The building under investigation is a room, corresponding to a conventional office. We chose not to simulate an entire building since this paper focuses only on actions of one occupant. The room geometry is given in Figure 1. The ceiling, the floor and the 3 inner walls (north, east and west) are assumed adiabatic. The south facade is the only wall in contact with the exterior. It is composed of a concrete layer and an insulating layer. The insulating layer location depends on the considered case study.

Physical characteristics of the walls and window are given in Table 1. Internal gains from lighting and occupation are added depending on a week-long working schedule. The following assessments are taken:

- blinds: when blinds are closed, 10% of incident solar radiations are transmitted to the window and no additional thermal resistance is taken into account.
- lighting system: internal gains due to artificial lighting system are equal to 9 W/m^2 of floor area.
Electric energy demand calculation for lighting system is based on a ratio of 11 W/m^2 of floor area.

- infiltration flow rate: a flow rate of 0.3 vol/h is assumed
- heating system: heating starts on November 1st and ends on April 30th. The set point temperature depends on the considered case study and the heating power is assumed unlimited.
- cooling system: cooling starts on 1st May and ends on 31st of October. Set point temperature depends on the considered case study and the cooling power is assumed unlimited.

2.2. Occupant thermal modeling

Heat transfer between the environment and the occupant's body with all physiological reactions are calculated with a 2-node model representing the human body with an added layer for clothing. The mean skin temperature and heat transfer are calculated by taking into account physical variables (air temperature and velocity, mean radiant temperature, and vapor pressure) and parameters depending on the body (metabolic heat production and clothing insulation).

Thermo-physiological unconscious reactions are computed such as vasoconstriction, vasodilatation, shivering and sweating. The thermal balance of human body is calculated at a time step of one minute, whereas the thermal balance of the building is calculated at a time step of one hour. The time step of the thermophysiological model is independent of the time step of the building simulation, as it is internal to the routine of the thermophysiology model.

Thermal sensations (ST) are then calculated on the ASHRAE seven-point scale from -3 (very cold) to +3 (very hot) thanks to regression relationships with skin temperature [37].

Usually it is considered that there is no main discomfort for a thermal sensation close to 0 (neutral). Thus thermal comfort could be reached. This is one of the strongest assumptions that is currently made in this field. In all simulations, the occupant is seated at rest. His metabolism is fixed to 1 met, close to 105 W. The clothing insulation varies according to actions and/or season.

1
2
3
4
5
6
7
8
9 *2.3. Modeling of occupants behavioral actions*

10 The aim of this study is to understand the impact of human behavioral
11 actions on his/her thermal sensation and energy demand. Each of the 6 actions
12 given in introduction has an impact either on the building or the human thermal
13 balance or both.
14

15 Each action has been modeled in TRNSYS 17 with the following assumptions:
16

- 17 • window: when open, air velocity on the body is equal to 0.5 m/s and
18 infiltration flowrate is increased by 5 m³/h.
- 19 • fan: when "on", air velocity on the body is equal to 0.6 m/s. The energy
20 demand of the fan is not taken into account in total energy demand.
- 21 • If the window is open and the fan is "on" at the same time, air velocity
22 on the body is equal to 0.8 m/s.

23
24
25
26
27
28
29
30
31 *2.4. Case studies*

32 We investigate several case studies through three variant parameters: cli-
33 mate, thermal inertia and air conditioning during summer.
34

- 35 • The location parameter takes two values, oceanic and Mediterranean. In
36 the first case, the building is situated in Agen (France), and in the second
37 case, the building is situated in Nice (France).
- 38 • The thermal inertia parameter takes two values depending on the location
39 of the insulation in the outer wall. If the insulating material is located on
40 the outer side, the thermal inertia is characterized as high and vice versa.
- 41 • The air conditioning parameter also takes two values, on and off. If on, it
42 means that the building is equipped with air conditioning during summer.

43
44
45
46
47
48
49
50
51 Since there are two possible values for each of the three parameters, eight
52 case studies are needed to perform all combinations. They are presented in
53 Table 2.
54
55
56
57
58

1
2
3
4
5
6
7
8
9 **3. Design of experiments methodology**

10
11 Typically, design of experiments (DOE) methods are used for of industrial
12 process optimization. They identify the most influencing factors on the effi-
13 ciency of a process, and find improvement levers. When several variables are
14 involved in an experimental design, the traditional one-factor-at-a-time method
15 (OFAT) becomes a weighty and time-consuming task.

16
17 In our case, the purpose is to determine the quantitative influence of occupants’
18 actions on energy building performance and thermal sensation. Thus, six ex-
19 perimental factors have to be investigated. A classical OFAT method would
20 need a large number of runs, so a 2^n *full fractional design* is preferred because
21 of its favorable accuracy/time compromise. It consists of assigning two levels
22 (low and high) to n factors and evaluating responses for the 2^n combinations.
23 In this study, $n = 6$ factors (or actions) are evaluated on two levels, thus 64
24 simulations have to be achieved for each response. Based on these results, a
25 post-treatment is performed thanks to the Yates algorithm which gives a linear
26 regression relationship between considered responses and factors (Equation 1).
27
28
29
30
31
32
33
34

35
36
$$Y = a_0 + \sum_{i=1}^n a_i \cdot X_i + \sum_{i,j=1}^n a_{ij} \cdot X_i \cdot X_j + \sum_{i,j,k=1}^n a_{ijk} \cdot X_i \cdot X_j \cdot X_k + \dots \quad (1)$$

37

38 Where Y is the response, X_i are the factors, n is the number of factors, and
39 $a_{ij\dots}$ are the estimated factor effects.

40
41
42 **3.1. Factors**

43
44 Factors of an experiment are the parameters that are supposed to influence
45 the responses. In this paper, the factors are the occupant’s actions. Each action
46 is assigned two levels. These are called ”low level” and ”high level”, respectively
47 -1 and +1.
48

49
50 Table 3 gives the assumptions for the states -1 and +1 for each action (i.e. fac-
51 tor). The conventional methodology in design of experiments is to take extreme
52 values in the range of variability of each actions. All the assumptions given in
53 Table 3 have been taken in that way.
54
55
56
57
58

For each action, the low and high levels have been chosen to correspond to lower and upper typical values. For example the low level for clothing corresponds to light clothing insulation for a given season.

3.2. Responses

Responses are the outputs of the experiments or simulations. These are the values on which factors have influence, and that the experimental designer chooses to analyze. The following responses are considered:

- Q_{heat} (kWh/m².yr): energy demand for heating
- Q_{tot} (kWh/m².yr): total energy demand for heating, cooling and lighting.
- SLT : negative thermal sensation defined in equation 2:

$$SLT = - \sum_{t=1}^{8760} ST(t)\Delta t, \forall ST(t) \in \mathbf{R}^{-*} \quad (2)$$

- SGT : positive thermal sensation defined in equation 3:

$$SGT = \sum_{t=1}^{8760} ST(t)\Delta t, \forall ST(t) \in \mathbf{R}^{+*} \quad (3)$$

Where $ST(t)$ is the thermal sensation of an occupant calculated by the thermophysiology model at time t , Δt is the time step of the simulation, 1 hour in this study.

3.3. Yates algorithm

Yates algorithm is used in order to exploit results of the Design Of Experiments methodology and thus quantify the impact of each action taken separately. It takes as input a matrix called “design matrix” to compute the impact, called main effect, of factors on different responses (energy demand, thermal sensation, etc.).

1
2
3
4
5
6
7
8
9 A design matrix is a table collecting all experiments that are performed.
10 Each experiment is characterized by a unique combination of six factors on low
11 level or high level. The design matrix contains $n + r$ columns (where n is the
12 number of factors and r the number of responses), and 2^n rows since factors
13 vary on two levels. The n first columns are filled with combinations of -1 and
14 +1. Yates algorithm needs the combinations to be in the Yates order which is
15 defined by:
16
17
18
19

- 20 • first row is filled with -1
- 21
- 22
- 23 • -1 and +1 values switch on the rows $2^n - 1$ in column n
- 24

25 Experimental results Y_k are written in columns $n + k$ ($1 \leq k \leq r$). The
26 structure of a generic matrix design for a 2^n full fractional design is given in
27 table 4.
28
29

30
31
32 Once the design matrix is established, estimated factor effects (a in Equation
33 1) are evaluated with the Yates algorithm [34]. They give the individual impact
34 of each factor on the various responses.
35
36
37
38

39 **4. Results and Discussion**

40
41
42 For each of the 8 case studies, 64 simulations have been performed with
43 TRNSYS 17 to estimate the main effect of the $n = 6$ actions on the $r = 4$
44 responses. That makes 512 simulations over one year.
45

46 After presenting some preliminary results from the building simulation, we in-
47 vestigate discrepancy over energy demand and thermal sensation. The variation
48 range of energy performance regarding the occupant actions, building charac-
49 teristics, and climate typology are studied.
50

51 Then, the impact of actions, taken individually, on energy demand and thermal
52 sensation is discussed.
53
54
55
56
57
58

1
2
3
4
5
6
7
8
9
4.1. Preliminary results

10
11 The energy performance results from these simulations are shown in Figure
12 2. Results have been averaged over the 64 simulations for each case study. They
13 categorized into 3 energy demands as follows:
14

- 15 • Q_{heat} , is the heating energy demand (one of the responses)
- 16
- 17 • Q_{light} is the energy demand for lighting,
- 18
- 19 • Q_{cool} is the cooling energy demand. ($Q_{cool} = 0$ when air conditioning is
20 off)
21
22
23

24 The sum of these 3 results represent Q_{tot} , the total energy demand, which is
25 one of the responses investigated in the DOE. The estimated demand appears
26 high, but this apparent overrating comes from the consideration of occupant's
27 actions as will be seen in the next part.
28

29 It is worth noting on Figure 2 that the ocean climate is the coldest as Q_{heat}
30 is higher. In all cases, Q_{cool} is quite low and Q_{light} represents between 10 and
31 15% of the total energy demand.
32
33
34
35
36

37 The evolution of indoor temperature and heating power demand over the
38 time is plotted on Figure 3. The building is in Agen and has low inertia. The
39 time correspond to the last week of January. The plot shows results from energy
40 simulation for two cases from the DOE:
41
42
43

- 44 • a minimal scenario where the combination of the different factors mini-
45 mizes the energy demands ($B = -1, E = -1, T = -1, F = +1, ALF$).
46 $Q_{tot} = 14 \text{ kWh/m}^2.\text{yr}$
47
- 48 • a maximal scenario where the combination of the different factors mini-
49 mizes the energy demands ($B = +1, E = +1, T = +1, F = -1, ALO$).
50 $Q_{tot} = 120 \text{ kWh/m}^2.\text{yr}$
51
52
53
54

55 They are the two extreme scenarii regarding the total energy demand (Q_{tot}).
56 Results show that there is about a nine-to-one factor between these two cases
57
58
59
60
61
62
63
64
65

1
2
3
4
5
6
7
8
9 which differ only in the occupant's actions. This wide discrepancy shows mag-
10 nitude of the impact of occupant on the building energy performance, even
11 though the results have to be nuanced because of the low probability of such
12 combinations of actions.
13
14

15 16 *4.2. Energy demand and thermal sensation discrepancy*

17
18 Eight other simulations have been performed taking conventional design
19 strategies used in France. The assumptions are presented in Table 5. Assump-
20 tions on blinds operations are based on [38, 39].
21

22 The aim is to compare classical design results to those from the DOE method-
23 ology which takes into account various occupant actions.
24

25 Figure 4 shows for the 8 cases the mean value and standard deviation of Q_{tot}
26 from the 64 simulations and show a significant discrepancy among 8 sets of sim-
27 ulations. These are due to the varying actions and show that different behaviors
28 could lead to very different energy performances. It has to be noticed that the
29 results for conventional design are always lower than the mean value of the 64
30 simulations. Discrepancies remain approximately constant regardless of the cli-
31 mate or the inertia of the building in terms of absolute value.
32
33
34
35
36
37

38 The Relative Standard Deviation (RSD) is calculated using Equation 4:

$$39 \quad RSD = \sigma_{Q_D} / \mu_{Q_D} \quad (4)$$

40
41
42
43 Where σ_{Q_D} is the standard deviation of the results from DOE simulations for
44 Q_{tot} and μ_{Q_D} is the mean.
45
46
47

48 On Figure 5, RSD has been plotted for each case. The figure shows that:

- 49 • Occupant's actions have a more significant impact on buildings under
50 warmer climate
 - 51 • Thermal inertia slightly depreciates the impact of the actions
- 52
53
54
55
56
57
58
59
60
61
62
63
64
65

1
2
3
4
5
6
7
8
9 The Error Factor (EF) is calculated using Equation 5:

$$EF = \mu_{Q_D} / Q_C \quad (5)$$

10
11
12
13
14 Where μ_{Q_D} is the mean of the results from DOE simulations for Q_{tot} , and
15 Q_C is the results from conventional design simulation for Q_{tot} .
16
17

18
19 Results on Figure 6 show that the EF between a conventional design process
20 and a design process taking into account the occupant actions is between 1.5 and
21 2. These differences are consistent with the feedback from the field, which often
22 brings out a two-to-one discrepancy between predicted and measured building
23 energy performance [18].
24
25

26 In addition, Figure 5 and 6 show that the relative impact of thr occupant varies
27 from the building type and climate. Indeed, the impact is more important for
28 a building with higher thermal inertia and located in a warmer climate. The
29 same building might have very different energy demands ($\pm 54\%$ in average on
30 Figure 5) depending on the behavioral profile of its occupants.
31
32

33 Current building design processes do not take into account this behavior suffi-
34 ciently. At the same time, buildings have become more efficient and the impact
35 of the occupant behavior in the energy balance has increased. That is why in-
36 creasingly wide discrepancies have been observed in the past decade.
37
38
39
40
41

42 Regarding the thermal sensation, Figure 7 shows that there is a significant
43 gap between SLT from DOE design strategy and the conventional design strat-
44 egy. This difference might be very prejudicial to future building energy perfor-
45 mance. Indeed, if occupants are in a situation of discomfort, they will react by
46 interacting with their environment and, might degrade energy performance.
47
48

49 That is why thermal comfort has to be considered in design strategies in order to
50 reduce future discrepancies between field measurements and simulation results
51 in terms of energy performance.
52
53
54
55
56
57
58

1
2
3
4
5
6
7
8
9 *4.3. Impact of actions on building energy demand*

10 The impact of global occupant behavior has been discussed above. It is the
11 result of combinations of different single actions (i.e. blind operations, light op-
12 erations, etc.). Therefore, it is essential to quantify individually the effect of each
13 action on the energy building performance. It would allow to bring out which
14 actions building designers should pay attention to predict more precisely future
15 energy performance. The impact of each actions has been calculated thanks to
16 the Yates algorithm and the 64×8 simulations results on 4 responses.

17 The Yates algorithm estimates the main effect of each input factor on the re-
18 sponses. The *main effect* is the mean impact of a factor on a considered response
19 when it goes from state -1 to +1. For example, if the main effect of a response's
20 factor is 100, it means that this response increase by 100 on average when this
21 factor is activated (state +1).

22 For convenience in analyzing the results, we introduce in Equation 6 the Rel-
23 ative Mean Main Effect (RMME). This indicator is intended to quantify the
24 average percentage of variation that a factor would be induce on a particular
25 response.
26
27
28
29

30
31
32
33
34
35
36
37
38
39
$$RMME = \frac{\overline{ME}}{\overline{R}} \quad (6)$$

40 Where \overline{ME} is the mean of the main effects of a factor for the 8 case studies,
41 and \overline{R} is the mean of a response for the same 8 case studies.
42
43
44
45

46 Figure 8 shows the absolute value of the RMME of the 6 actions on the
47 response Q_{tot} , and Figure 9 shows the absolute value of the RMME of the same
48 6 actions on the response Q_{heat} . A positive main effect means that the action
49 leads to increased energy demand. On the contrary, a negative value means that
50 the action is beneficial for the building's energy performance.
51
52
53
54

55 Figure 8 and 9 show that the temperature set point (action T) is the most
56
57
58

1
2
3
4
5
6
7
8
9 influential factor. A difference of 4°C in the temperature set point during oc-
10 cupied hours is responsible for an increase of 35 to 55% in the total energy
11 demand (Figure 8). In the same way, the action T leads to an increase of 50
12 to 70% in heating energy demand (Figure 9). That is why it is essential either
13 to design efficient regulation systems, or to forecast accurately the occupant
14 “comfort temperature”, whether or not he has control on the heating systems.
15 Blinds (B) play also a major role in building performance. It turns out that
16 blind operation might increase total energy demand by about 20% and heating
17 energy demand by about 35%. Here again, actions on blinds have to be care-
18 fully considered during the design process. Conventional modeling considers
19 that blinds are fully open during winter (Table 5). However, field studies show
20 a completely different reality. Indeed, Foster [40] shows that blinds could be
21 closed up to 60% in average in winter. Significant errors might be made on
22 solar gains and thus on building performance of modern buildings for which the
23 energy balance is profoundly affected by solar gains.

24
25 Regarding operations on the lighting system (L), Figure 8 shows that light influ-
26 ences significantly the total energy demand. Current models of lighting system
27 are based on occupied schedules, which is a wrong assumption if the controls are
28 operable by the occupants. Occupants do not systematically switch on lights
29 when they arrive to their office or switch off when they leave it [8, 10]. Figure
30 9 shows that lights have a negative effect on the heating energy demand, which
31 is due to the heat produced by the lighting systems. Eventually, wrong as-
32 sumptions regarding lights operations could lead to an underevaluation of total
33 energy demand, and thus bring an uncertainty of several percents to building
34 energy performance.

35
36 Results also show that the operation of windows decreases the total energy
37 demand, albeit to a lesser extent than the actions above. It decreases indoor
38 temperature and thus the air conditioning demand.

39
40 Figure 8 shows that the other investigated actions (fan and clothing) do not
41 affect building’s energy performance directly. They are related to the thermal
42 sensation of occupants.

1
2
3
4
5
6
7
8
9 *4.4. Impact of actions on thermal sensation*

10 The Design Of Experiments method used in the present paper does not take
11 into account interactions between thermal or visual comfort and actions. Ac-
12 tions such as fan operations or clothing adjustments have a null RMME on
13 building performance (Figures 8 and 9).
14

15 However, actions of occupants are often the manifestation of a certain discom-
16 fort. For example, an occupant with a negative thermal sensation will tend to
17 increase the temperature set point and thus increase the heating energy demand.
18 Occupants thermal comfort is an important factor in building performance be-
19 cause of its close connection to occupants behavior.
20

21 Figure 10 and 11 show the RMME of the 6 actions on SLT (Eq. 2) and SGT
22 (Eq. 3). Results evaluate the impact of actions on thermal sensation. Not
23 surprisingly, the most influential factor on thermal comfort is the temperature
24 setpoint (T). A difference of 4°C in temperature set point causes a reduction of
25 cold discomfort of about 35 to 50%, assuming comfort is reached for a neutral
26 thermal sensation.
27

28 Figures 10 and 11 show that clothing (C) is a major factor in thermal sensation.
29 Indeed, it is responsible for wide variations on SLT and SGT. Since thermal
30 discomfort might be a source of degradation of energy performance, thermal
31 clothing insulation must not be treated as a trivial consideration. The famous
32 “Cool Biz” campaign [41] of the Japanese ministry of the environment, where
33 office employees were asked not to wear ties and jackets, permitted the saving
34 of hundred thousands of tons in CO₂ emission, thus demonstrating the crucial
35 role of the clothing.
36

37 The third most important action on thermal sensation is the operation on blinds.
38 Blinds prevent solar radiation from passing through windows and thus increas-
39 ing the gain. It has to be underlined here that even if the sun enters the room,
40 the occupant is not in the sunspot. Otherwise, the effect on warm sensation
41 would be largely increase.
42

43 Figure 10 shows that the closing of external shading devices causes an important
44 rise of cold discomfort. This can be explained by a negative thermal balance
45
46

1
2
3
4
5
6
7
8
9 during mid-season periods when the heating system is turned off. On the other
10 hand, Figure 11 shows that blinds are able to decrease significantly (between
11 -15 to -28%) the occupant discomfort during summer season.
12
13
14

15 16 17 **5. Conclusion** 18

19 Currently, building simulation models consider occupants in simplistic ways.
20 Yet, many studies tend to show this leads to large discrepancies between sim-
21 ulated and measured energy demands. Indeed, very few studies quantify the
22 impact occupants have on building energy performance.
23

24 In this paper, we propose a new method to quantify this impact and the re-
25 lated discrepancies caused by occupants actions. To do this, we use the Design
26 Of Experiments methodology, based on the modeling of various combinations
27 of extreme behaviors (-1 and +1 levels) in a building simulation model. We
28 study 6 actions an occupant could do: operations on blinds, lights, windows,
29 setpoint temperatures, fans, and personal clothing insulation. We have chosen
30 as responses to these 6 actions the energy use and the thermal comfort. The
31 building studied is an office room. Eight cases are investigated according to
32 3 parameters which are climate, inertia and air conditioning system. Our ob-
33 jective is to quantify and range the impact of each action on the responses. In
34 addition, results are compared to the ones of a conventional reference case which
35 does not take into account the occupant's actions.
36
37

38 Our study permits to bring out the following conclusions:
39
40
41
42
43

- 44 • for a given case study energy use can be very different according to the
45 occupant actions. The impact of the actions leads to a variation of the
46 RSD higher than 45% (Figure 5).
47
- 48 • conventional design methodology undervalues the energy demand (two-
49 to-one factor) because they do not consider occupants behavior (Figure
50 6).
51
52
53
54
55
56
57
58

- it also overvalues occupants' thermal comfort (Figure 7).
- The most influential actions on total energy demand are the operations on setpoint temperature, blinds, and lights (Figure 8).
- The most influential actions on thermal comfort are the operations on setpoint temperature, clothing insulation, and blinds (Figure 10 and 11).

Building simulation cannot be performed anymore without considering occupant's behavior. It have to be taken into consideration during the building design phase in order to reduce the gap between simulation and actual energy performance [30]. This can be achieved with different methods using artificial intelligence [28]. Without these considerations, there is a significant risk of discrepancies between calculated and actual energy use.

1
2
3
4
5
6
7
8
9 **References**

- 10
11 [1] R. Socolow, Saving energy in the home: Princeton’s experiments at Twin
12 Rivers, Ballinger Pub. Co., 1978.
13
14
15 [2] R. C. Sonderegger, Movers and stayers: the resident’s contribution to vari-
16 ation across houses in energy consumption for space heating, *Energy and*
17 *Buildings* 1 (3) (1978) 313–324.
18
19
20 [3] T. Maier, M. Krzaczek, J. Tejchman, Comparison of physical performances
21 of the ventilation systems in low-energy residential houses, *Energy and*
22 *Buildings* 41 (3) (2009) 337–353.
23
24
25 [4] A. I. Rubin, B. L. Collins, R. L. Tibbott, Window blinds as a potential
26 energy saver: A case study, US Department of Commerce, National Bureau
27 of Standards, 1978.
28
29
30
31 [5] M. S. Rea, Window blind occlusion: a pilot study, *Building and Environ-*
32 *ment* 19 (2) (1984) 133–137.
33
34
35 [6] T. Inoue, T. Kawase, T. Ibamoto, S. Takakusa, Y. Matsuo, The develop-
36 ment of an optimal control system for window shading devices based on
37 investigations in office buildings, *ASHRAE transactions* 94 (1988) 1034–
38 1049.
39
40
41 [7] D. R. G. Hunt, The use of artificial lighting in relation to daylight levels
42 and occupancy, *Building and Environment* 14 (1) (1979) 21–33.
43
44
45 [8] J. A. Love, Manual switching patterns in private offices, *Lighting Research*
46 *and Technology* 30 (1) (1998) 45–50.
47
48
49 [9] S. Pigg, M. Eilers, J. Reed, Behavioral aspects of lighting and occupancy
50 sensors in private offices: a case study of a university office building,
51 *ACEEE 1996 Summer Study on Energy Efficiency in Buildings*.
52
53
54 [10] D. Lindelöf, N. Morel, A field investigation of the intermediate light switch-
55 ing by users, *Energy and Buildings* 38 (7) (2006) 790–801.
56
57
58

- 1
2
3
4
5
6
7
8
9 [11] J. F. Nicol, M. A. Humphreys, Adaptive thermal comfort and sustainable
10 thermal standards for buildings, *Energy and Buildings* 34 (6) (2002) 563–
11 572.
12
13
14 [12] S. Herkel, U. Knapp, J. Pfafferoth, A preliminary model of user behaviour
15 regarding the manual control of windows in office buildings, in: *Proceedings*
16 *of the 9th International IBPSA Conference BS2005*, Montreal, Canada,
17 2005.
18
19
20
21 [13] J. Nicol, Characterising occupant behaviour in buildings: towards a
22 stochastic model of occupant use of windows, lights, blinds, heaters and
23 fans, in: *Proceedings of the seventh international IBPSA conference*, Rio,
24 Vol. 2, 2001.
25
26
27
28 [14] R. De Dear, A global database of thermal comfort field experiments,
29 *ASHRAE Transactions* 104 (1998) 1141–1152.
30
31
32 [15] A. Mahdavi, People in building performance simulation, *Building perfor-*
33 *mance simulation for design and operation* (2011) 56–83.
34
35
36 [16] C. Whang, D. Yan, Y. Jiang, A novel approach for building occupancy
37 simulation, *Building simulation* 4 (2) (2011) 149–167.
38
39
40 [17] J. Virote, R. Neves-Silva, Stochastic models for building energy prediction
41 based on occupant behavior assessment, *Energy and Buildings* 53 (0) (2012)
42 183 – 193.
43
44
45 [18] L. Norford, R. Socolow, E. Hsieh, G. Spadaro, Two-to-one discrepancy
46 between measured and predicted performance of a low-energy office build-
47 ing: insights from a reconciliation based on the doe-2 model, *Energy and*
48 *Buildings* 21 (2) (1994) 121 – 131.
49
50
51
52 [19] P. A. Torcellini, M. Deru, B. Griffith, N. Long, S. Pless, R. Judkoff,
53 D. Crawley, *Lessons learned from field evaluation of six high-performance*
54 *buildings*, National Renewable Energy Laboratory, 2006.
55
56
57
58
59
60
61
62
63
64
65

- 1
2
3
4
5
6
7
8
9 [20] G. R. Newsham, S. Mancini, B. J. Birt, Do leed-certified buildings save
10 energy? yes, but?, *Energy and Buildings* 41 (8) (2009) 897–905.
11
12 [21] C. J. Hopfe, J. L. Hensen, Uncertainty analysis in building performance
13 simulation for design support, *Energy and Buildings* 43 (10) (2011) 2798 –
14 2805.
15
16 [22] C. M. Clevenger, J. Haymaker, The impact of the building occupant on
17 energy modeling simulations, in: *Proceedings of the Joint International*
18 *Conference on Computing and Decision Making in Civil and Building En-*
19 *gineering*, Montreal, Canada, 2006.
20
21 [23] P. Hoes, J. Hensen, M. Loomans, B. De Vries, D. Bourgeois, User behavior
22 in whole building simulation, *Energy and Buildings* 41 (3) (2009) 295–302.
23
24 [24] F. Haldi, D. Robinson, Adaptive actions on shading devices in response
25 to local visual stimuli, *Journal of Building Performance Simulation* 3 (2)
26 (2010) 135–153.
27
28 [25] C. Reinhart, Lightswitch-2002: a model for manual and automated control
29 of electric lighting and blinds, *Solar Energy* 77 (1) (2004) 15–28.
30
31 [26] K. J. McCartney, J. F. Nicol, Developing an adaptive control algorithm for
32 europe, *Energy and Buildings* 34 (6) (2002) 623–635.
33
34 [27] M. Endravadan, F. Thellier, J. P. Bedrune, Modelling of occupant-
35 controlled global heating in buildings, in: *Proceeding Windsor Conference,*
36 *Post Occupancy Evaluation: Closing the Loop*, 2004.
37
38 [28] M. Bonte, F. Thellier, B. Lartigue, An occupant behavior model based on
39 artificial intelligence for energy building simulation, in: *Proceedings of the*
40 *13th International IBPSA Conference BS2013*, Chambéry, France, 2013.
41
42 [29] F. Haldi, D. Robinson, Interactions with window openings by office occu-
43 pants, *Building and Environment* 44 (12) (2009) 2378 – 2395.
44
45
46
47
48
49
50
51
52
53
54
55
56
57
58
59
60
61
62
63
64
65

- 1
2
3
4
5
6
7
8
9 [30] The International Energy Agency (IEA), Annex 53 - Total energy use in
10 buildings: Analysis & evaluation methods (2010).
11
12 URL www.ecbcsa53.org
13
14 [31] T. Hong, H.-W. Lin, Occupant behavior: Impact on energy use of private
15 offices, in: Proceedings of ASim 2012, 2013.
16
17 [32] Statistical Methods for Testing and Evaluating Defense Systems: Interim
18 Report, The National Academies Press, 1995.
19
20 [33] R. A. Fisher, The design of experiments, Edinburgh and London: Oliver
21 and Boyd, 1935.
22
23 [34] F. Yates, The Design and Analysis of Factorial Experiments, Imperial Bu-
24 reau of Soil Science, 1952.
25
26 [35] V. C. Chen, K.-L. Tsui, R. R. Barton, J. K. Allen, A review of design
27 and modeling in computer experiments, Handbook of statistics 22 (2003)
28 231–261.
29
30 [36] The solar energy laboratory, uw-madison (2011).
31
32 URL <http://sel.me.wisc.edu/trnsys/index.html>
33
34 [37] M. Galeou, La sensation thermique de l’homme dans son habitat : des
35 grandeurs physiques et physiologiques aux sensations, Ph.D. thesis, Uni-
36 versite Paul Sabatier Toulouse III, France (1991).
37
38 [38] D. Saelens, W. Parys, R. Baetens, Energy and comfort performance of
39 thermally activated building systems including occupant behavior, Building
40 and Environment 46 (4) (2011) 835–848.
41
42 [39] W. Parys, D. Saelens, H. Hens, Implementing realistic occupant behavior
43 in building energy simulations—the effect on the results of an optimization
44 of office buildings, in: Proceedings of the 10th REHVA World Congress
45 “Sustainable Energy use in Buildings”, 2010.
46
47
48
49
50
51
52
53
54
55
56
57
58
59
60
61
62
63
64
65

- 1
2
3
4
5
6
7
8
9 [40] M. Foster, T. Oreszczyn, Occupant control of passive systems: the use of
10 venetian blinds, *Building and Environment* 36 (2) (2001) 149–155.
11
12 [41] H. Masaki, Japans new energy strategy, *Energy Perspectives on Singapore*
13 and the Region (2007) 228–248.
14
15
16
17
18
19
20
21
22
23
24
25
26
27
28
29
30
31
32
33
34
35
36
37
38
39
40
41
42
43
44
45
46
47
48
49
50
51
52
53
54
55
56
57
58
59
60
61
62
63
64
65

List of figure captions

- Figure 1 Room geometry
- Figure 2 Mean energy demand distribution vs case study reference
- Figure 3 Temperature and power demand over a week for the minimal (ALF) and the maximal (ALO) scenario
- Figure 4 Total energy demand vs case study reference
- Figure 5 Relative Standard Deviation (RSD) of total energy demand vs case study reference
- Figure 6 Error ratio between mean of DOE results and results from standard occupant model
- Figure 7 SLT vs case study reference
- Figure 8 Total energy demand vs action
- Figure 9 Heating energy demand vs action
- Figure 10 Negative thermal sensation indicator SLT vs action
- Figure 11 Positive thermal sensation indicator SGT vs action

Table 1: Main characteristics of walls and window

Surface	U-value ($W.m^{-2}.K^{-1}$)	Area (m^2)	g (%)
Outwall	0.248	9	-
Inwall	0.248	42	-
Window	1.4	3	0.589
Roof, Floor	0.438	20	-

Table 2: Case studies depending on parameters combination

Location	Agen				Nice			
Thermal inertia	Low		High		Low		High	
Air conditioning	On	Off	On	Off	On	Off	On	Off
Case reference	ALO	ALF	AHO	AHF	NLO	NLF	NHO	NHF

Table 3: Factors of the fractional design

	Action	Unit	Low level (-1)	High level (+1)
B	Blinds	-	opened for the whole year	closed the whole year
L	Lights	-	switched off for the whole year	switched on during occupation schedule ^a
W	Window	-	Closed for the whole year	Open when the outdoor temperature is less than the indoor temperature during summer and the outdoor temperature is greater than 23 °C.
T	Tsp	°C	Winter : 18°C during the occupation schedule, 17°C otherwise. Summer and if air-conditioning is on : 28°C	Winter : 24°C during the occupation schedule 17°C otherwise. Summer and if air-conditioning is on : 24°C.
F	Fan	m/s	switched off for the whole year	switched on when indoor temperature exceeds 26°C
C	Clothing	clo	winter 0.9 summer 0.5	winter 1.1 summer 0.7

^a Occupation schedule starts at 8 am and ends at 7 pm during weekdays.

Table 4: Design matrix structure for a 2^n full fractional design and responses

	Factors				Responses		
Exp	X_1	X_2	...	X_n	$Y_1(X_1, X_2, \dots, X_n)$...	$Y_r(X_1, X_2, \dots, X_n)$
1	-1	-1	...	-1	$Y_1(-1, -1, \dots, -1)$...	$Y_r(-1, -1, \dots, -1)$
2	+1	-1	...	-1	$Y_1(+1, -1, \dots, -1)$...	$Y_r(+1, -1, \dots, -1)$
...
2^n	+1	+1	...	+1	$Y_1(+1, +1, \dots, +1)$...	$Y_r(+1, +1, \dots, +1)$

Table 5: Assumptions of conventional French design strategy

	Action	unit	Assumptions	Reference
B	Blinds	-	closed when total radiation on facade exceeds 250 W.m^{-2} and opened when total radiation on facade is lower than 150 W.m^{-2}	-
L	Lights	-	switched on during occupied hours	-
W	Window	-	closed all year long	French thermal regulation (RT2012)
T	Tsp	°C	Winter : 19°C and 17°C during night; Summer : 26°C and no air conditioning during night	French thermal regulation (RT2012)
C	Clothing	clo	winter: 1 summer: 0.6	ISO 7730

Figure 1
[Click here to download high resolution image](#)

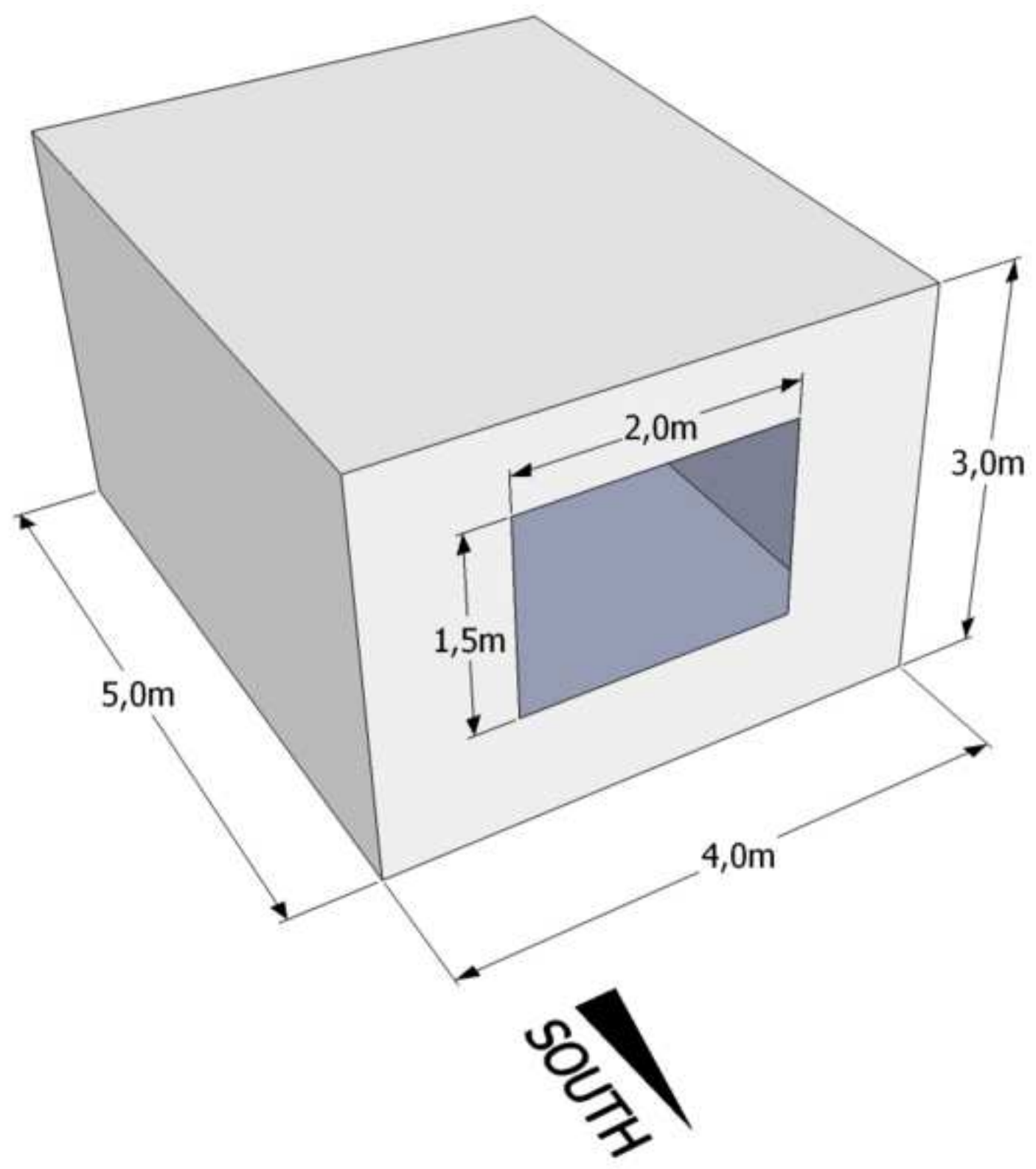

Figure 2
[Click here to download high resolution image](#)

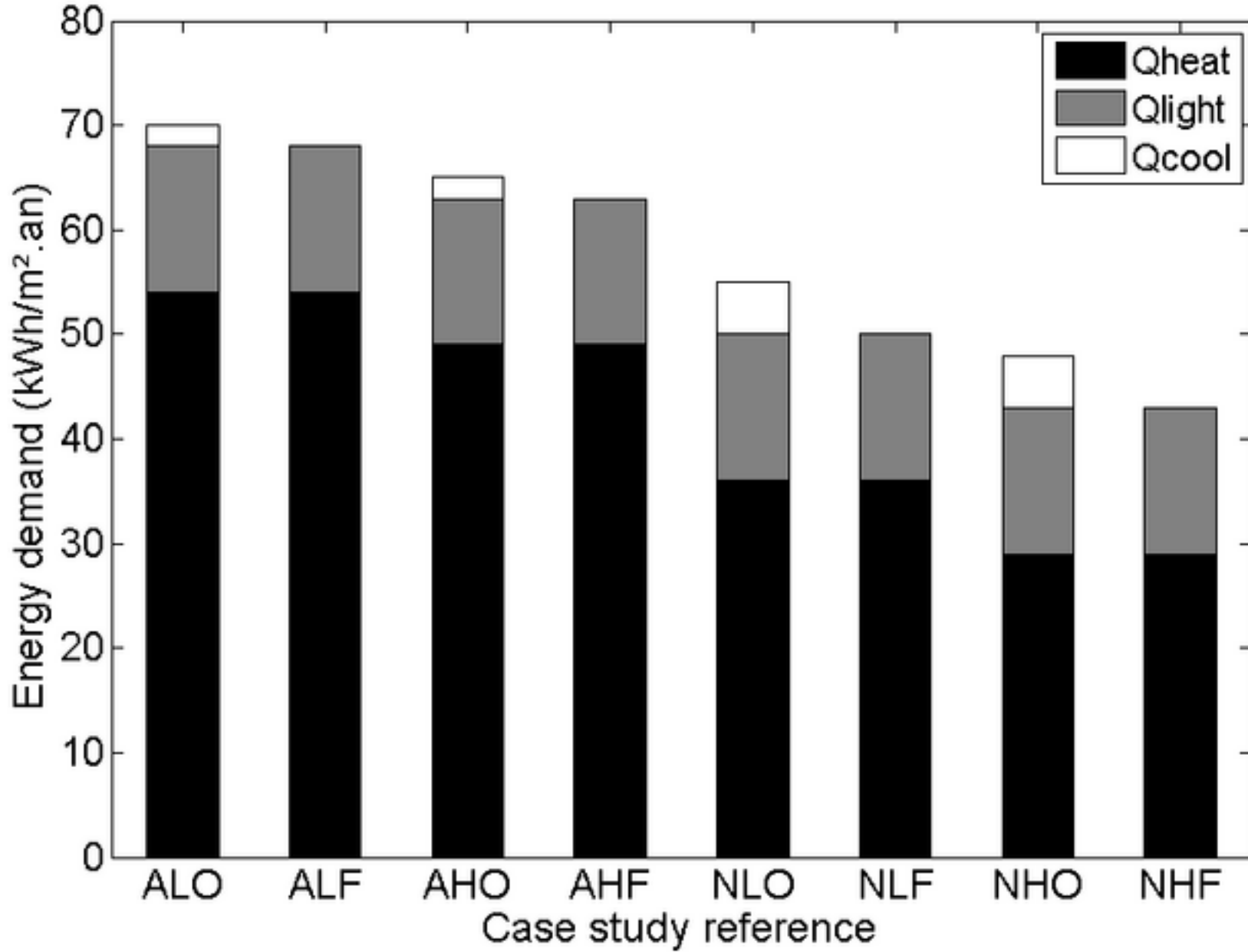

Figure 3
[Click here to download high resolution image](#)

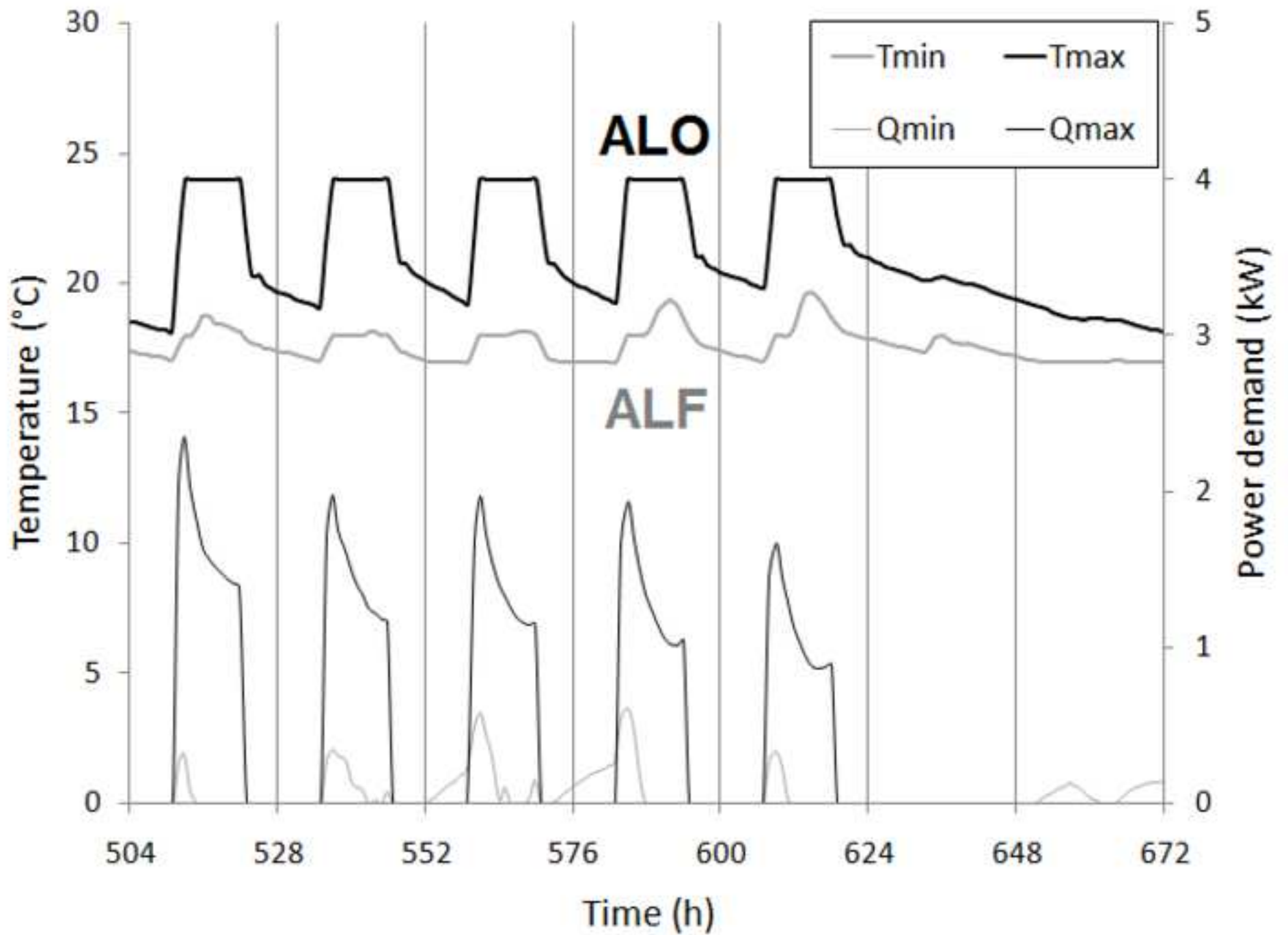

Figure 4
[Click here to download high resolution image](#)

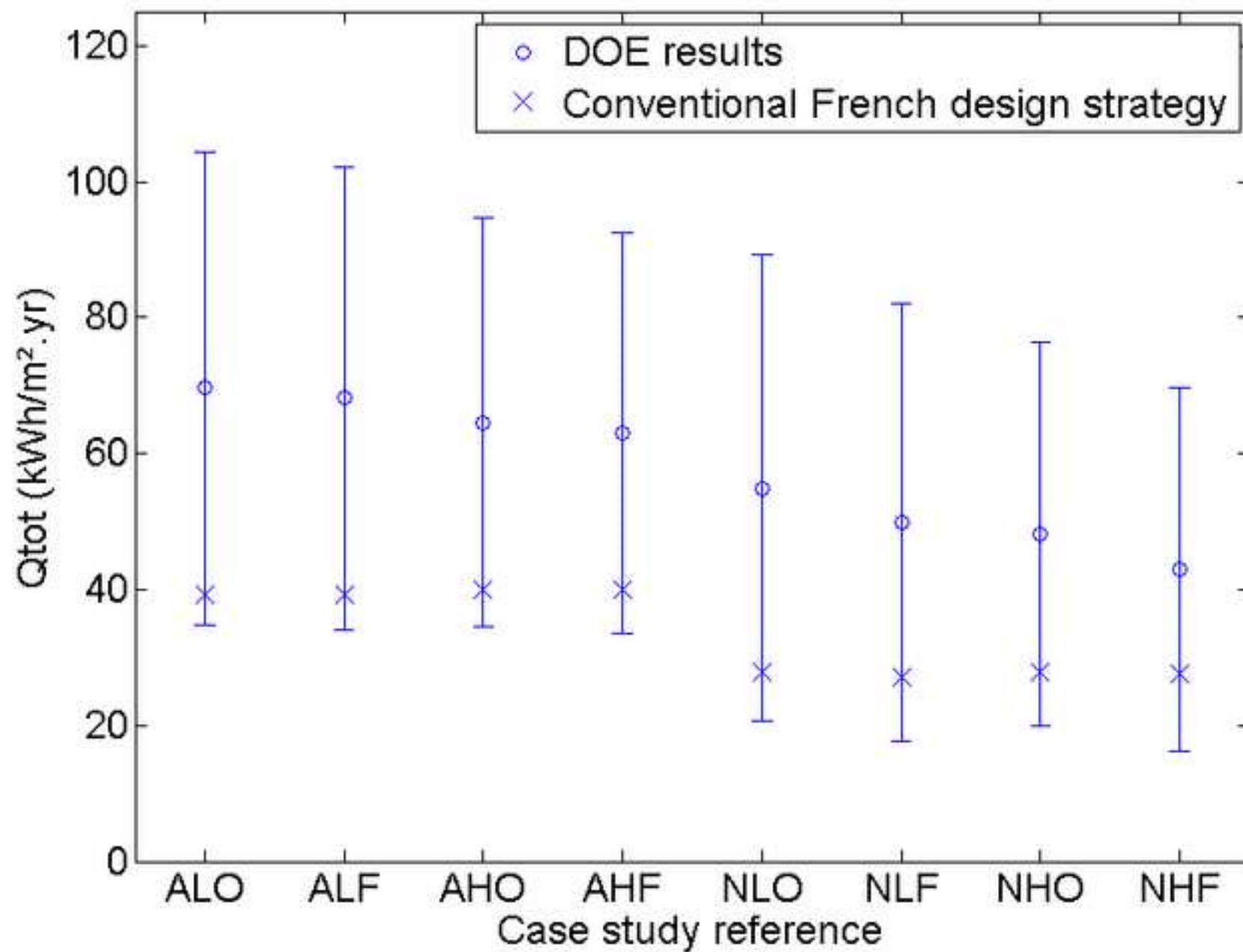

Figure 5
[Click here to download high resolution image](#)

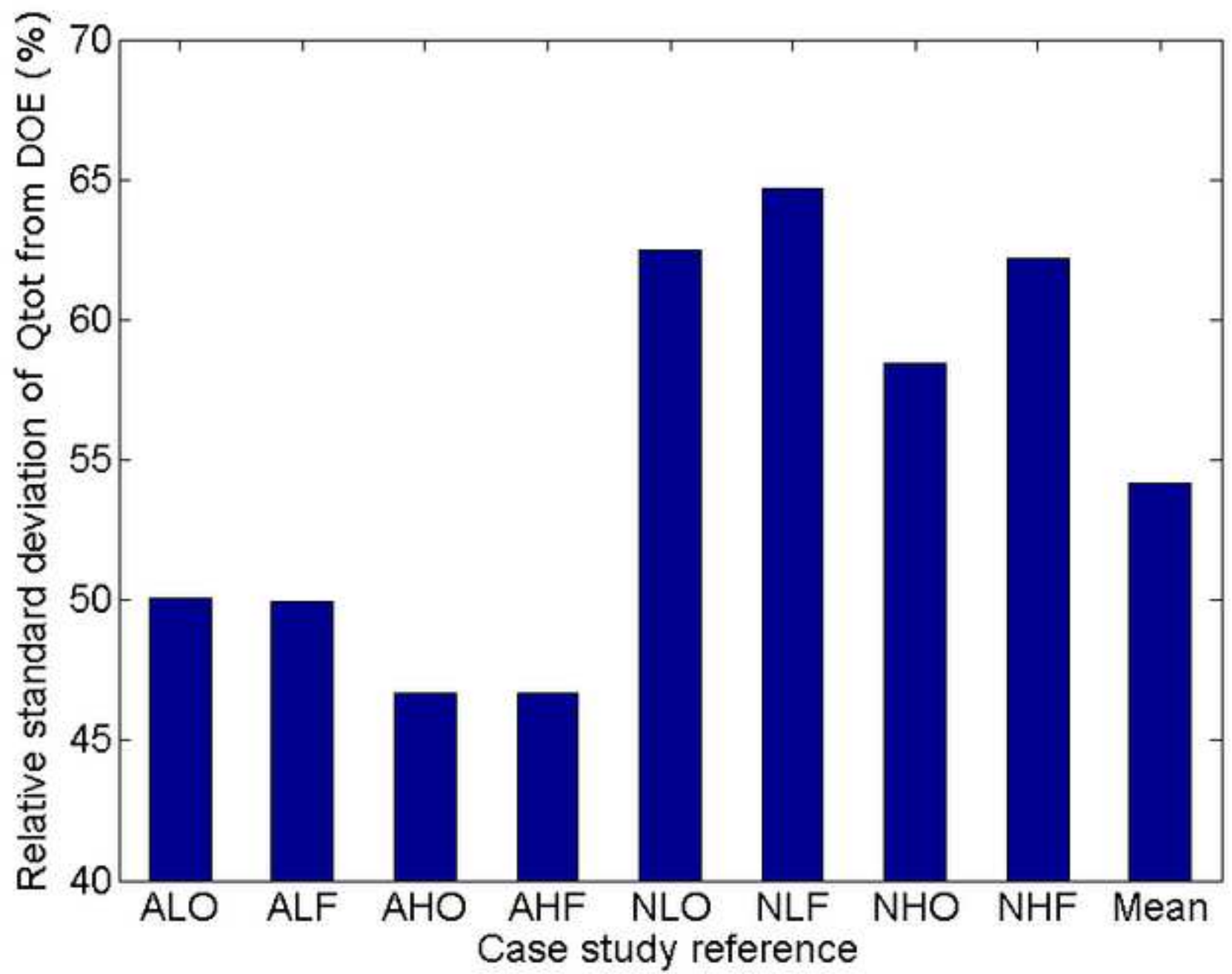

Figure 6
[Click here to download high resolution image](#)

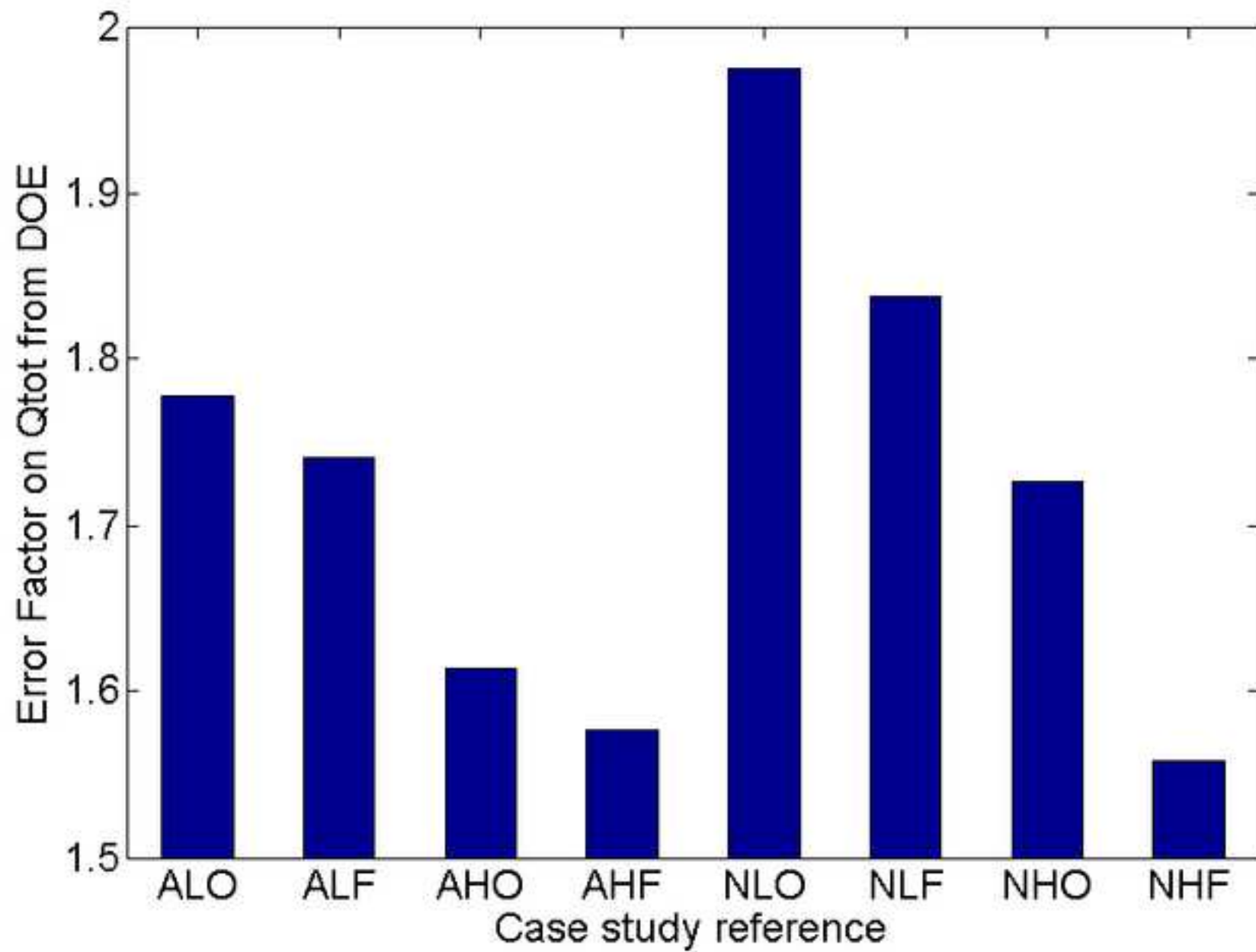

Figure 7
[Click here to download high resolution image](#)

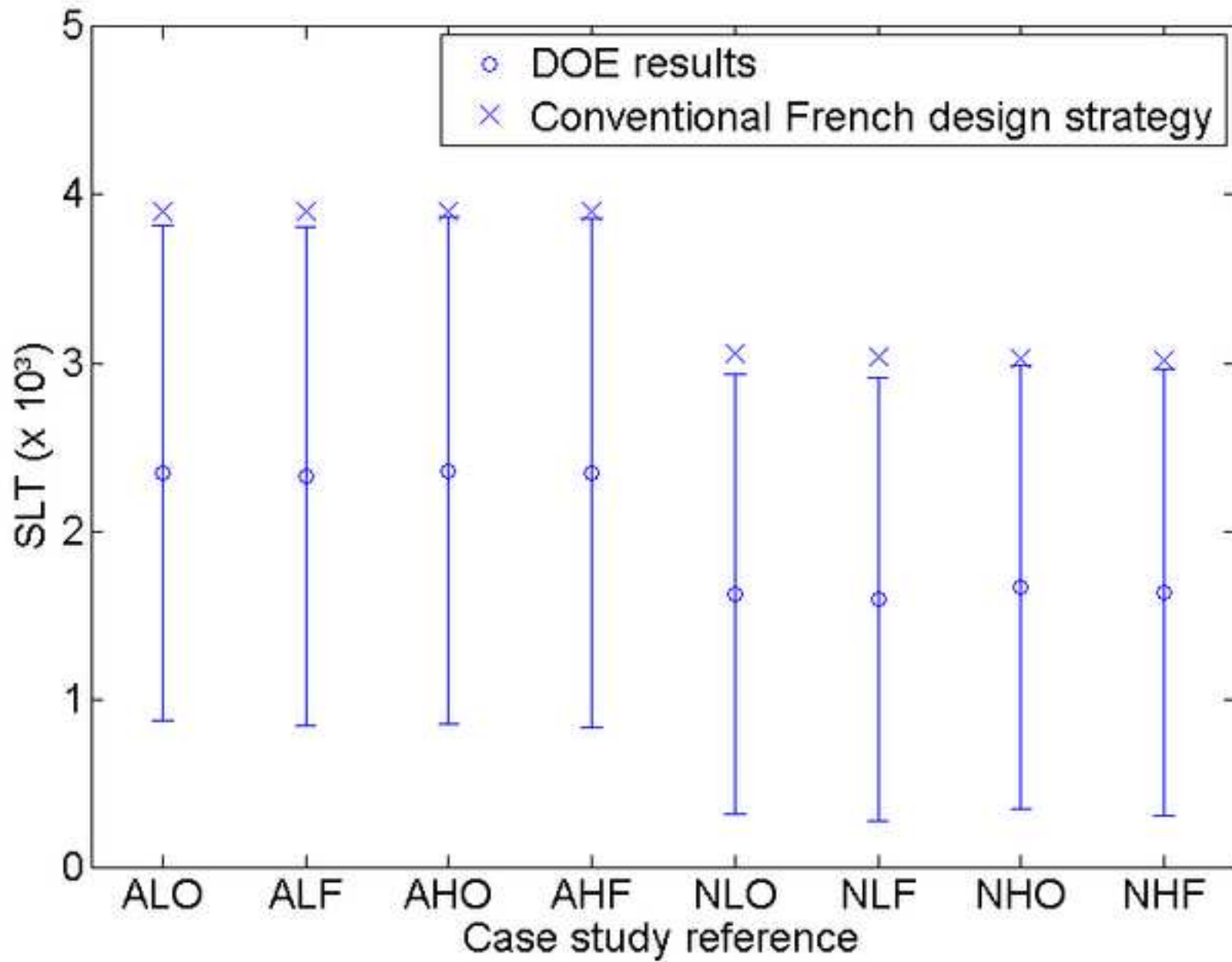

Figure 8
[Click here to download high resolution image](#)

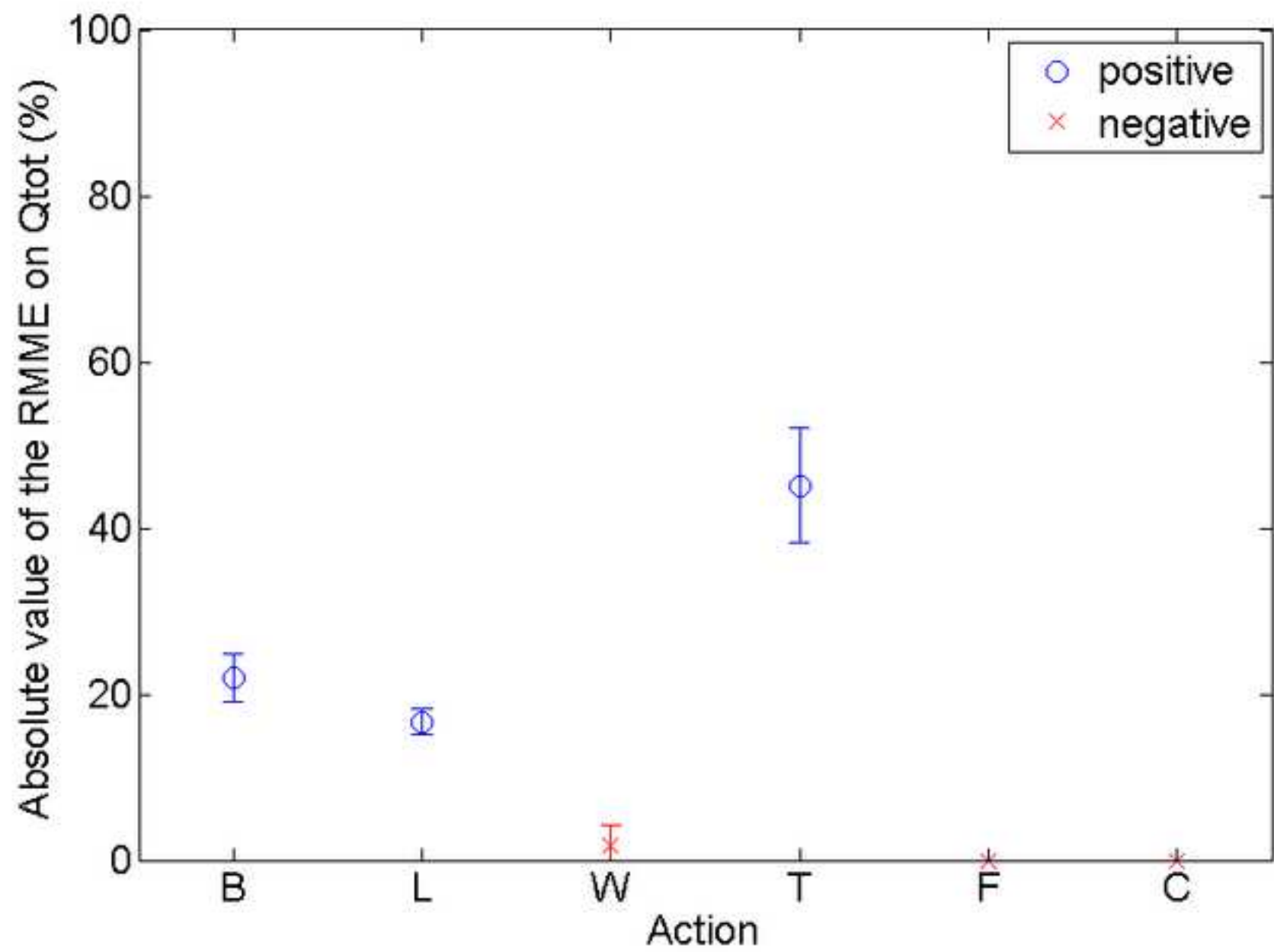

Figure 9
[Click here to download high resolution image](#)

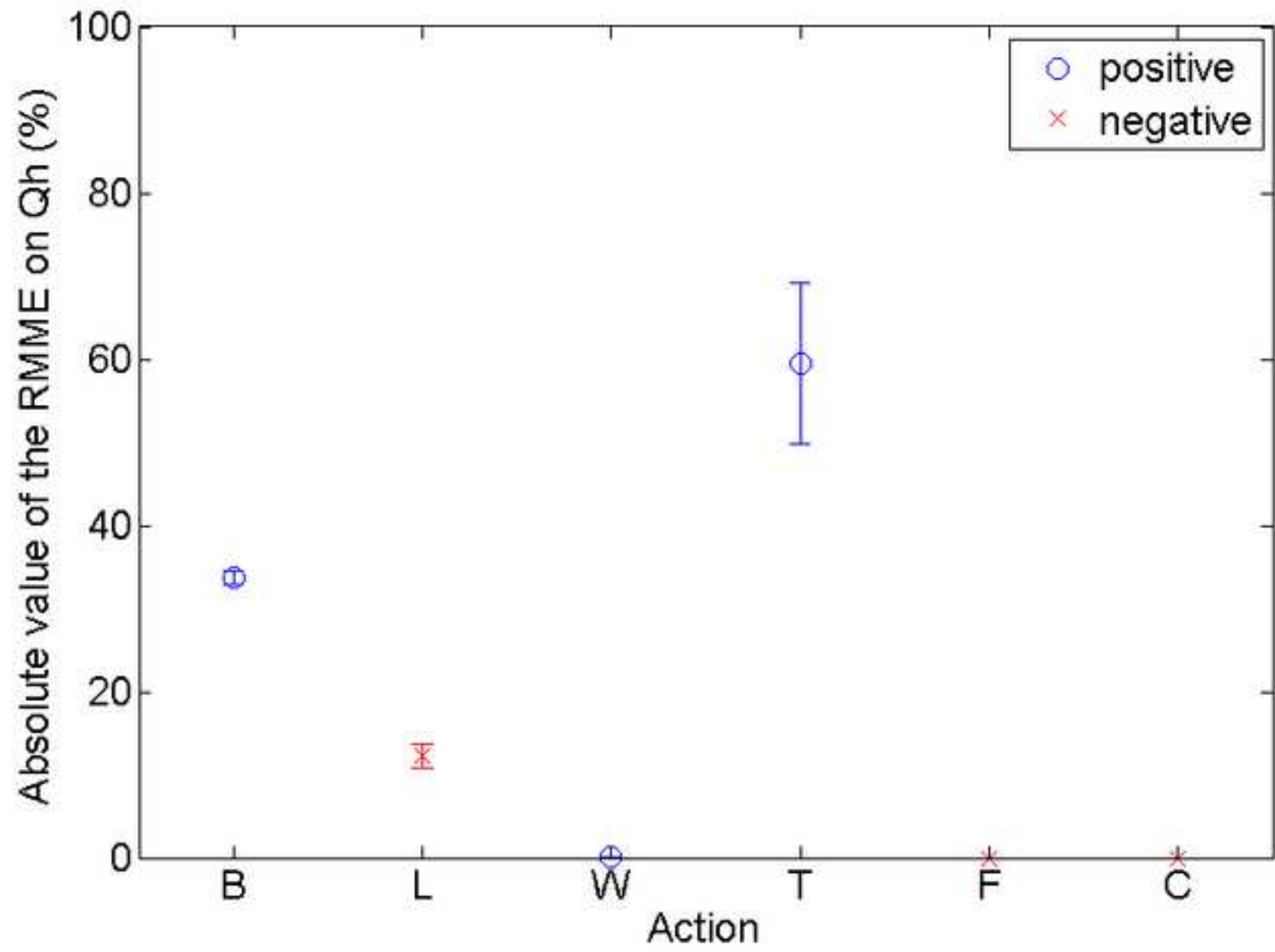

Figure 10
[Click here to download high resolution image](#)

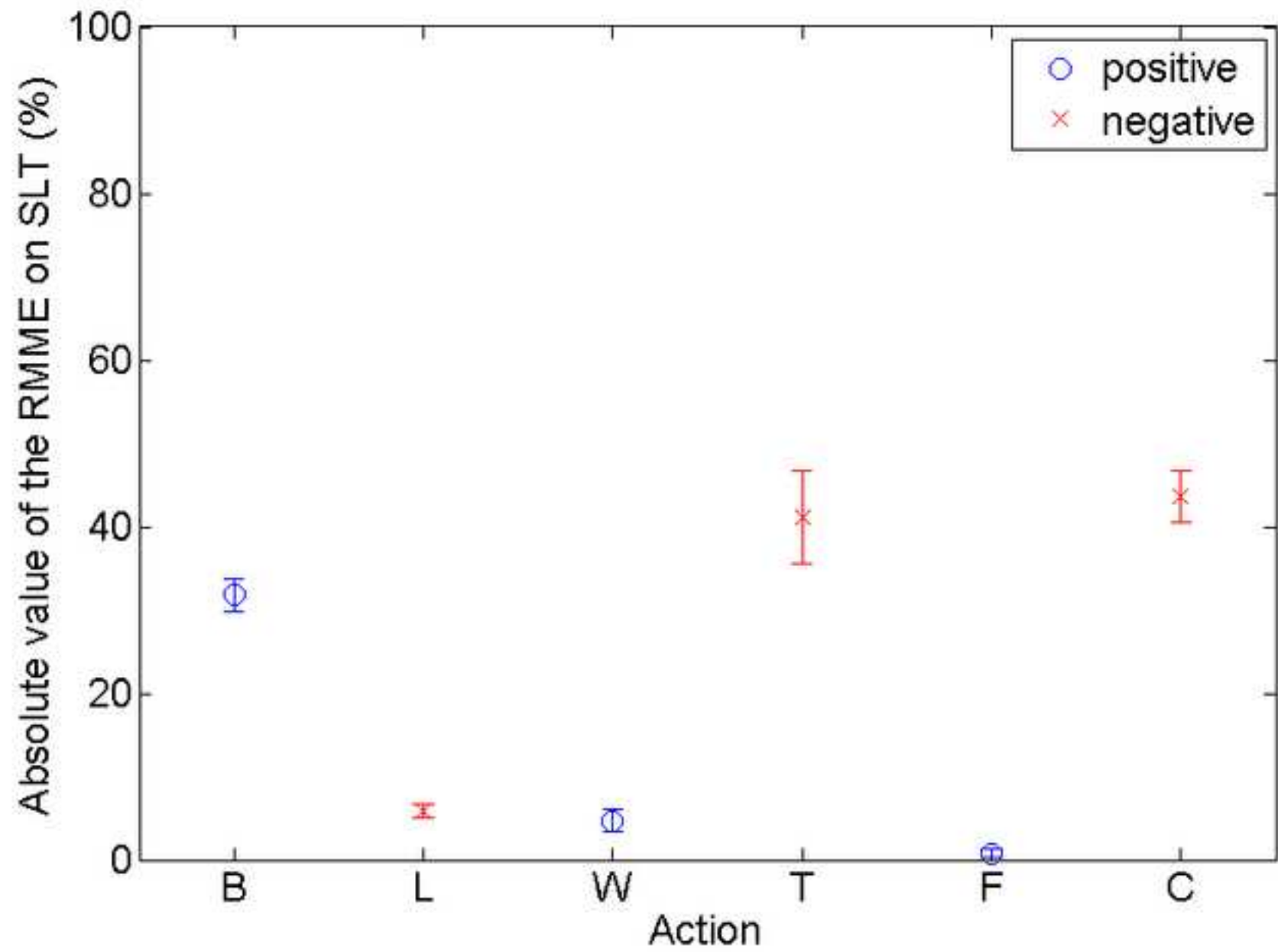
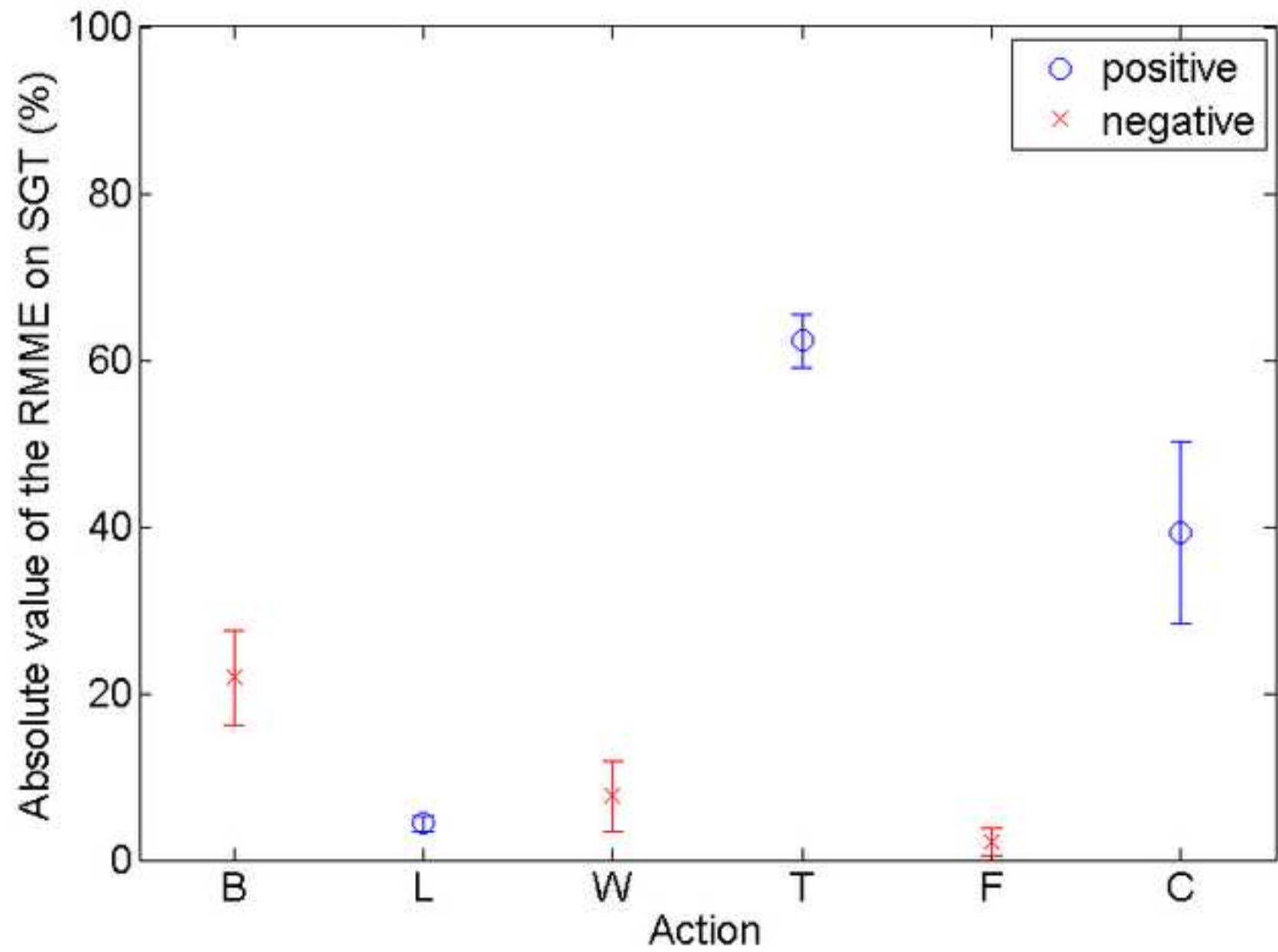

Figure 11
[Click here to download high resolution image](#)



Highlights

- We assess the impact of occupant's actions on building performance.
- The occupant's actions lead to significant uncertainties ($\pm 45\%$ on energy use).
- Conventional design methods undervalue energy use (2 to 1 factor).
- Conventional design methods undervalue thermal discomfort.