



HAL
open science

Finding Innovative Technical Solutions in Patents Through Improved Evolution Trends

Ulises Valverde, Jean-Pierre Nadeau, Dominique Scaravetti

► **To cite this version:**

Ulises Valverde, Jean-Pierre Nadeau, Dominique Scaravetti. Finding Innovative Technical Solutions in Patents Through Improved Evolution Trends. TRIZ – The Theory of Inventive Problem Solving, SPRINGER, pp.1-42, 2017, 978-3-319-56593-4. hal-02173034

HAL Id: hal-02173034

<https://hal.science/hal-02173034v1>

Submitted on 4 Jul 2019

HAL is a multi-disciplinary open access archive for the deposit and dissemination of scientific research documents, whether they are published or not. The documents may come from teaching and research institutions in France or abroad, or from public or private research centers.

L'archive ouverte pluridisciplinaire **HAL**, est destinée au dépôt et à la diffusion de documents scientifiques de niveau recherche, publiés ou non, émanant des établissements d'enseignement et de recherche français ou étrangers, des laboratoires publics ou privés.

Chapter 1

Finding Innovative Technical Solutions in Patents Through Improved Evolution Trends

Ulises Valverde, Jean-Pierre Nadeau, and Dominique Scaravetti

Abstract Patents represent a reservoir richly endowed with exploitable technical information, where a structured exploration of inventions can unveil essential knowledge for solving industrial problems. Several authors exploit patents using the evolution laws of the TRIZ theory to anticipate technological leaps, categorize patents in a TRIZ perspective, forecast technology, etc. TRIZ laws can be completed with Polovinkin's rules, design rules, better known as "design heuristics," and the rules of the art of engineering (engineering best practices). In this chapter, we propose evolution trends composed of all these elements and presented in the form of cards to assist users. After selecting pertinent patents, they can be classified into discovery matrices and analyzed in a timeline classification structured according to their technological branches. The evolution trends enable us to decipher the evolution in inventions being followed or to be followed by each technological branch. An in-depth analysis of several technological branches linked to the technical problem in question allows us to inspire users with original ideas, identify opportunities for innovation, and propose hybrid solutions. To illustrate our approach, we look for possible evolutions of current, deep offshore biphasic separation systems.

1.1 Introduction

Patent databases are truly a mine of information for designers. It is important that this information be structured in order to transform it into knowledge. Using functional analysis and functional energy decomposition, patents can be understood in a particular way. An initial analysis is carried out by crossing the physical phenomena involved with the technologies used. The search can then be developed using keywords from an energy study based on the first law of evolution of TRIZ.

U. Valverde (✉) • J.-P. Nadeau • D. Scaravetti
Arts et Métiers ParisTech, I2M, UMR 5295, 33400, Bordeaux, France
e-mail: Ulises.Valverde@ensam.eu; Jean-Pierre.NADEAU@ensam.eu;
Dominique.SCARAVETTI@ensam.eu

© Springer International Publishing AG 2017
D. Cavallucci (ed.), *TRIZ – The Theory of Inventive Problem Solving*,
DOI 10.1007/978-3-319-56593-4_1

1

The next step is to use this knowledge, classified by timeline, to determine innovation opportunities. To this end, we draw up a list of studies on evolution trends in technical systems. Next, we describe our own method and structure the knowledge in the form of a discovery matrix, which shows the evolution of patents over time for each technology/physical phenomenon combination. Next, we propose evolution trend cards based on the TRIZ evolution laws, Polovinkin's rules, design heuristics from the I2M laboratory, and engineering best practices.

Our application case concerns the improvement of a biphasic separator deep offshore. Currently, according to oil production and reserves, the oil industry needs to exploit previously untapped reserves. Oil processing in offshore platforms at great depths leads oil companies to design complex separation systems. In some offshore oil fields gas/liquid separation is key. It is indeed essential to separate the gas from the liquid at the sea bottom in order to pump the viscous liquid to the surface. However, beyond a depth of 3000 m, voluminous biphasic gravity separators are a big problem and an industrial challenge. Existing systems are based on the principle of decantation, but several constraints must be considered, i.e., residence time, the sporadic production of liquid and gas, sand management, etc. In this context, our methodology aims to exploit patents and find possible innovative solutions.

This chapter is organized as follows. Section 1.2 addresses what already exists in terms of evolution laws, rules, and design heuristics for analyzing and evaluating a technical system. We give a few examples from various authors who exploit patents using the evolution laws for different purposes. Section 1.3 briefly presents a problem-solving methodology used to recover pertinent patents that will be classified in a discovery matrix. In Sect. 1.4, we continue with our evolution trends proposal that will be applied to a case related to biphasic separators (Sect. 1.5). We conclude with a discussion and future prospects.

1.2 State of the Art: Anticipating the Evolution of Technical Systems

A trend can be defined as the progressive routing of an entity. In an engineering context, it can be defined as “an early identification of the gradual transformation of a technical system.” In effect, identifying the “technology trends” followed by a system provides designers with new ideas to innovate and, in some cases, enables them to solve complex technical problems.

Industrial property plays an essential role in problem-solving, innovation, and creativity; in fact, patents have served as a source of inspiration for deducing evolution trends followed by technical systems. Nowadays, several methods are used to exploit patent documents, such as evolution trends and several automatic techniques, frameworks, tools, etc., to assist design activities.

Table 1.1 TRIZ evolution laws

TRIZ Law	Description
Law of wholeness of system	The CTOC decomposition ^a comes from this law; it is to verify wholeness of the converters components, transmitter, operator, and control/command. An energy functional flow ensures the realization of the action
Law of energy conductivity	It is necessary to ensure continuity of energy flow among functional elements of the system (free energy path between components)
Law of coordination of rhythms	The frequencies and component behavior periodicity must contribute to a global optimum
Law of increase in the degree of perfection	Any system tends to evolve first by increasing complexity and then tends to be simplified
Law of uneven development of parts of a system's entities	Each entity has its own evolution, when the entity arrives at its decline, this blocks the evolution of the whole system
Law of transition from the macro-level to the micro-level	This law states the evolution to increased use of fields toward nanotechnology
Law of transition to a super-system	A system that has achieved its development limit will exchange functionalities with the surrounding environment. The final evolution is the integration into the surrounding environment
Law of dynamism and increase of controllability	The system passes from static to dynamic in order to act on the system; the energy fields go toward the immateriality to improve controllability
Law of increase of degree of ideality	The development of all systems tends to increase the degree of ideality (reduction of mass, volume, energy consumption, etc.)

^aThe CTOC method (Converter, Transmitter, Operator, Control/Command) was initially proposed by Pailhès et al. (2011)

The following sections address the origin of the laws, rules, and heuristics that make up our evolution trends proposal with some examples of their use.

1.2.1 Altshuller's Evolution Laws

In the 1940s, the Russian engineer and scientist, Genrich Altshuller, having studied more than 40,000 patents, developed objective laws (also known as the TRIZ evolution laws) that describe the evolution of technical systems and allow product designers to anticipate the evolution of a product. He relied on his observation, patent analysis, and the study of what exists (Altshuller 1984, 1994; Altshuller and Seredinski 2004). These laws are described in Table 1.1 by a former colleague of Altshuller, Salamatov (1996). The laws were originally presented in three groups: static, kinematic, and dynamic. In the context of this chapter, we have adapted the description of some of them.

In a more recent work, Mann (2002) sought to evolve the Soviet theory by adapting and complementing the classical TRIZ laws. He proposed a classification into 30 generic technical evolution trends and 20 commercial (business field) trends. Often encountered in the literature as Mann evolution trends, they refer to this author's classification into three categories: space, time, and interface.

Mann (2003) proposes a design method to support companies in identifying the relative maturity of their existing systems, and also in identifying areas where there is evolutionary potential. The author introduced the term "evolutionary potential," which is defined as the difference between the relative maturity of the current system and the point where it has reached the limits or bounds of each evolution trend. This method is mainly used for the evolution of complex technical systems. It enables industry, first, to identify areas where their technical systems can potentially evolve to create value and, second, to find out if the evolution limits of their technologies have already been reached.

Various patent analysis methods that look at technical evolutions are based on the TRIZ evolution laws. As a part of the design activities, these laws have been extensively used by many authors to identify evolution trends automatically in patent texts (e.g., Yoon et al. 2012; Park et al. 2013; Yoon and Kim 2011). In order to deduce technical evolutions, these authors exploit Mann's classification and propose several tools that use different computer techniques, especially in the field of computer linguistics.

By contrast, the evolution laws are also used by authors who employ nonautomatic methods. Based on the principle that the TRIZ evolution laws describe the state or situation of the evolution of a system or product, Zouaouaragab (2012) uses the evolution laws to predict future product generations. Drawing on the works of various authors, she has compiled several definitions of evolution laws, and models the first five laws. The aim of this approach is to guide designers toward the identification of the greatest number of possible developments of innovative products. This nonautomatic approach uses surveys and manual information extraction for data collection.

1.2.2 Polovinkin's Rules

The word "heuristic" (from the ancient Greek *Heurisko*) was coined by the French philosopher René Descartes. It means: "*Which serves to discover or the art or science of discovery and finding.*"

The heuristic method was founded in the former USSR where it was used extensively. Professor Alexander I. Polovinkin selected different heuristics from the problem-solving best practices used by engineers and USSR machine designers (Polovinkin 1991). According to Polovinkin, heuristics or "decision rules" contain brief guidelines to show designers in which direction they should look or how to transform a prototype to solve a given problem. They encourage designers to think,

Table 1.2 The 12 groups of Polovinkin's rules (Polovinkin 1988)

Group	Rule	Number
1	Transformation of shape	16
2	Transformation of structure	19
3	Transformation in space	16
4	Transformation in time	8
5	Transformation of motion and strength	14
6	Transformation of matter and substances	23
7	Differentiation	12
8	Quantitative changes	12
9	The use of preventive measures	22
10	The use of reserves	13
11	Transformations by analogy	9
12	Increased ease of manufacture	16

but they do not give the answer. These heuristics are general and are issued to students, beginner engineers, and inventors (Polovinkin 1988).

The various works and examples by Polovinkin are difficult to find; they are in Russian, which means they cannot be understood and applied by an international public. Through the efforts of some contemporary authors, Polovinkin's rules have been translated into English (Savransky 2000) accompanied by several examples (Savransky et al. 2000) and translated into French by Scaravetti (2004). We have directly translated certain passages from the original Russian texts (Valverde 2015).

The basics of heuristics are linked with the basics of industry. They consist of 180 rules, classified into 12 groups (Table 1.2). These are general rules applicable to machines, tools, appliances, technologies, etc.

The purpose of these rules is to help make problem-solving more effective by reusing past experience to generate solutions to new problems. The rules act as explicit instructions, i.e., examples that represent solutions to past problems act as sources of descriptions for other problems. These rules have a global character and meaning, a large spectrum of application, and can be related to heuristics as being rules that have not been proved (or cannot be proven), but which need no justification as they leave no room for doubt.

Polovinkin's rules have the advantage that they can be implemented without a defined methodological framework. Their application enables the covering of a broad spectrum within the space of possible solutions because of the generic and universal character of the rules. However, there is no formalization of the design problem to be solved, which can consequently result in a somewhat ineffective application of the rules.

Let us consider some of the many examples described by Polovinkin where application of the rules is relevant and feasible:

- Regarding group 8, "Quantitative changes," Rule 8.1 states: *To change dramatically (several times, dozens of times, and hundreds of times) one or more*

Table 1.3 Excerpt from Polovinkin’s rules, Rule 3 (de Carvalho et al. 2004)

Rule	Description
3	Transformation in space
3.1	To change traditional orientation of the system in space: horizontal instead of vertical or inclined; to turn the system on its side or upside down; to turn the system by rotation
3.2	To use a previously unused (i.e., an empty) space between subsystems. One subsystem can pass through a cavity that exists in the other subsystem
3.3	To unite known separate subsystems by locating one inside the other, as in Russian nested dolls (<i>Matrioshka</i>)
3.4	To change the settlement along one line by accommodation along a few lines or on planes. Inversion of expedient
3.5	To replace location on a plane by accommodation on several planes or in three-dimensional space; to proceed from one-layer configurations to multilayer. Inversion of expedient
3.6	To change the direction of action of an operation (or a whole process) or environment
3.7	To proceed from contact in a point to contact on a line; from contact on a line to contact on a surface; from contact on a surface to volumetric (spatial) contact. Inversion of expedient
3.8	To carry out interface on several surfaces
3.9	To bring instruments into the operative zone (the place where functions are fulfilled by tools) without moving other subsystems or the whole system
...	...

parameters of the object (its elements, the environment, etc.), for instance, a water jet of up to 10 megapascals erodes the soil. Increasing water pressure to 100 megapascals enables a water jet to cut stone and metal.

- The arc lamp was invented by the Russian inventor Pavel Yablochkov in 1875 (Julien 2000). In the original system, there were two carbon rods (arranged along a straight line, with one in front of the other or at an angle) and an electric arc was produced between them. To maintain this arc, the rods had to be brought close together so that they were at a (constant) distance, sufficient to ensure combustion. This was achieved using a special automatic regulator. Despite its success, in practice it had some major flaws due to the complexity of the regulators that were unreliable, and combustion of the electrodes was not uniform. At the time, a simple technical solution was required to ensure the correct combustion of the two-electrode lamp. To solve the problem, Polovinkin suggested using *the rules relating to transformation in space (3.1, 3.4, 3.7, and 3.9)* (Table 1.3). Yablochkov then realized that the electrodes should be placed close together in parallel, separated by consumable insulators.

de Carvalho et al. (2004) consider the TRIZ theory and its tools [the 40 inventive principles, the 76 standard solutions, Substance-Field (Su-field) and ARIZ¹] to be a

¹ARIZ is the acronym for the Russian: “Алгоритм решения изобретательских задач,” translated into English as “Algorithm of Inventive Problem Solving.”

very substantial, but unfinished, body of work, a methodology undergoing improvement which can be effectively completed by Polovinkin's rules. They present a smaller version with 121 heuristics classified into eight groups (the most relevant being in the TRIZ context), translated, adapted, and illustrated by different examples drawn from patent analysis. They introduce heuristics as rules, strategies, principles, or methods to increase efficiency in problem-solving. They claim that heuristics do not provide direct or precise answers, nor do they guarantee solutions to problems. Nevertheless, they do provide assistance that facilitates problem-solving.

To highlight the importance of these rules and of complementarity in design activities, it must be stressed that they complement the various existing approaches. A comparison by Savransky and Wei (2001) of the creative TRIZ principles and Polovinkin's rules shows that fewer than a third of the 121 heuristics compared are linked directly to the TRIZ principles, which means that the rest of the heuristics enhance these principles.

1.2.3 Design Heuristics

More recent work by the I2M-IMC department² (Calle-Escobar et al. 2014) uses Polovinkin's rules in a problem-solving context. The authors specify that, historically, problems have usually been approached either via the basic experience and know-how of the design engineers, or by arbitrary choices from suggestions by company managers (or key figures), or via the history of society. The authors stress the importance of establishing design rules backed by the knowledge of a number of stakeholders to guide designers through the choices they make. To achieve this, they suggest producing models that can be structured in the form of problem-solving strategies.

Heuristics refer to procedures or approaches that allow a designer to reach a solution to a particular problem. These heuristics are based on experience and observation rather than on an exhaustive process. In the design context, reference is made to technical or conceptual solutions that have been implemented and have already been tested in another domain or context, but which can be extrapolated to similar design problems. According to the authors, design rules are global in nature and have a wide spectrum of application.

They look at the eight groups proposed by de Carvalho et al. (2004) and also consider the ninth group defined by Savransky (2000) (Table 1.4).

The heuristics developed by I2M-IMC are based on TRIZ (evolution law, principles of innovation, standard solutions), Polovinkin's rules, and rules of the art of engineering and have been validated by different laboratory studies.

²Institute of Mechanics and Engineering—Bordeaux (I2M), Department of Mechanical Engineering and Design (IMC).

Table 1.4 Reduction of Polovinkin’s rules to nine groups (de Carvalho et al. 2004; Savransky 2000)

Group	Name of the group
1	Transformation of shape
2	Transformation of structures
3	Transformation in space
4	Transformation in time
5	Transformation of movements and mechanical actions
6	Transformation of materials
7	Differential resources
8	Quantitative modifications
9	Transformations related to evolutionary trends

To explain how a group of heuristics is constructed, we demonstrate how to construct heuristics for the modification of a component (Figs. 1.1 and 1.2). This modification may be local, global, or an adaptation of the component.

- The first sub-branch (local modification) is for solving the problem at the place where it occurs. Innovation principle 3 (TRIZ, local quality) is used with the proposition of the location of a function. The introduction of a local substance is directly linked with class 1 (and, of course, also with class 5) of TRIZ standard solutions.
- For a problem linked with coupling physical phenomena, the designer uses traditional decoupling techniques which introduce a very well-known principle—that of segmentation. This is why, in branch A.2 (Fig. 1.1), we propose to segment in succession the overall structure, the components, and finally the internal flows. The following levels of branch A.2 concern segmentation typologies. These heuristics are the result of innovation principles (1, 3, 7, 17, 24, 26, 30, 40), evolution trend 6 (bi- and polysystems), standard solutions 223 and 226, and also rules of the art of engineering.

In studies carried out at I2M-IMC, there are 78 design heuristics. When grouped together they comprise a decision tree, part of which is shown in Fig. 1.3.

These heuristics are given in the form of problem-solving strategies expressed by a sentence constructed from the cause/effect analysis performed by designers (Calle-Escobar et al. 2014).

A succession of choices is then produced for the user in the tree diagram. For example, depending on the branch, the directions that the designer could opt for could give the following sentence:

“Reduce the problem by acting on the system by modifying and adapting components by evolution of the shape in an alternative Symmetrical/Asymmetrical vision.”

A. Through the modification of the components	
A.1. Locally	
A.1.1.	Locating actions
A.1.2.	Introducing a substance (Locally)
A.2. Globally	
A.2.1. Through the segmentation of the structure of the components	
A.2.1.1.	By layers
A.2.1.2.	Into identical elements, hollow elements, by dissociating their functions or interpenetrating them
A.2.1.3.	Through porous media or the introduction of a void
A.2.2. Through the segmentation of the components	
A.2.2.1.	Through the division into independent, removable, modular or adjustable components
A.2.2.2.	Through the division into independent, increasingly smaller elements (solid to pellets, to powder, etc.)
A.2.2.3.	Into identical components in order to increase effectiveness
A.2.2.4.	Into different components with identical functions, different functions, inverse or opposite functions
A.2.2.5.	Making them evolve from homogenous to heterogeneous (or vice versa)
A.2.2.6.	Into components with independent functions, optimized and/or conditional (according to available resources, life situation)
A.2.2.7.	Into components with opposite characteristics (insulating/conductive, rigid/deformable)
A.2.3. Through the segmentation of the flows	
A.2.3.1.	By introducing a permanent or non-permanent flow (according to life situations, available resources)
A.2.3.2.	Virtually (infrared vision, ultraviolet, vibrating behavior) or using images or reflections for a change of scale
A.2.3.3.	By passing from a planar contact (uniform mechanical field) to a point contact (discrete mechanical field) or vice versa
A.2.3.4.	By passing from a deformable system to a rigid system by changing the behavior of components: flexion to tension + compression (lattice), then tension or compression only (preload) (or vice versa)

Fig. 1.1 Heuristic (A), branches one and two

The designer then has to interpret this explicit sentence in the context of design, in order to express solutions.

1.2.4 Patent Exploitation Through the Evolution Laws of Technical Systems

Exploiting patents using Altshuller's evolution laws and inventive principles is the subject of research of many authors working on problem-solving and design activities. Most of them attempt to extract useful information from patent documents and link it with the TRIZ evolution laws (Yoon et al. 2012; Park et al. 2013; Yoon and

A. Through the modification of the components	
A.1. Locally	
A.2. Globally	
A.3. Through the adaptation of the components	
A.3.1. Through the evolution of the flow	
A.3.1.1. Dynamizing the component	
A.3.1.1.1.	Passing from a rigid to an articulate system (1, 2 or n articulations); to a flexible/deformable system; to a fluid system (gas, liquid); to a field with controlled fields (or vice versa)
A.3.1.1.2.	Passing from a rigid to a deformable system through the modification of the behavior of the components, from traction or compression independently, to traction+compression (truss) and then flexion (or vice versa)
A.3.1.2. Through the coordination of rhythms	
A.3.1.2.1.	Coupling by phase, by opposing phase, by resonance or compensation
A.3.1.2.2.	Through the transformation of a continuous action into a periodical action (or vice versa)
A.3.1.2.3.	Through the modification of the frequency or amplitude of a periodical action or energy
A.3.1.2.4.	By increasing the frequency of vibration up to ultrasonic vibrations
A.3.1.3. Through the modification of movements between components	
A.3.1.3.1.	Through the substitution of a linear movement for a rotating movement (or vice versa)
A.3.1.3.2.	Through the introduction of internal movements
A.3.1.3.3.	Replacing sliders for bearings (or vice versa)
A.3.1.3.4.	With the purpose of not fighting against gravity (or centrifugal effects) or using gravity (or centrifugal effects)
A.3.1.4. Following the MATHEM logic of field evolution	
A.3.1.4.1.	Through the replacement or superposition of one mechanical flow for another mechanical flow (thermal, optical, chemical, acoustic, etc.)
A.3.1.4.2.	Through the utilization of a magnetic, electric or electromagnetic field
A.3.1.4.3.	Through the evolution of the field, from stationary to dynamic, constant to variable, random to structured (or vice versa)
A.3.1.5. For the reduction of deformations	
A.3.1.5.1.	Passing from a rigid to a deformable system through the modification of the behavior of the components, from traction or compression independently, to traction+compression (truss) and then flexion
A.3.2. Through the evolution of materials	
A.3.2.1. Towards standardization or diversification	
A.3.2.2. Towards porous materials (embedded or charged) or multimaterials	
A.3.2.3. Using coatings with different properties	
A.3.2.4. From rigid to deformable (or vice versa)	
A.3.2.5. From expensive to inexpensive (or vice versa)	
A.3.2.6. Using their differentiating properties (isotropic, anisotropic)	
A.3.2.7. According to their state (solid, liquid, gas, etc.)	
A.3.2.8. Changing phase	
A.3.2.9. Superposing the fields to modify their characteristics	
A.3.2.10. Towards materials with properties that change over time	
A.3.3. Through the evolution of the shape	
A.3.3.1. Changing the spatial dimension, from 1D to 2D, up to 3D (or vice versa)	
A.3.3.1.1.	Following the evolution: linear, circular, spiral (or vice versa)
A.3.3.1.2.	Following the evolution: linear, planar, curved (or vice versa)
A.3.3.2. Into an alternative vision	
A.3.3.2.1.	Symmetric/ Asymmetric
A.3.3.2.2.	Convex/Concave
A.3.3.3. Adapted to the materials	
A.3.3.3.1.	According to mechanical stress
A.3.3.3.2.	According to fabrication or industrialization
A.3.3.3.3.	In order to be coherent with the utilization of a coating
A.3.3.3.4.	Using shape memory
A.3.3.4. Optimized according to the requirements criteria	
A.3.3.4.1.	Mass
A.3.3.4.2.	Size
A.3.3.4.3.	Cost
A.3.3.4.4.	Requirements

Fig. 1.2 Heuristic (A), branch three

Kim 2011, etc.). Other authors attempt to classify patents according to the inventive principle or law that they follow (Loh et al. 2006; Li et al. 2012, etc.). In any case, the evolution laws are an interesting means to exploit patents.

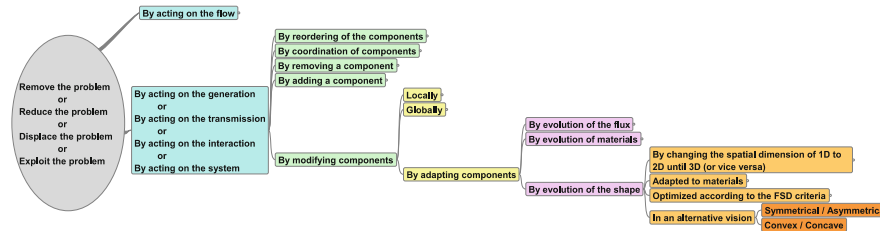

Fig. 1.3 Representation of one heuristic branch

A few relevant examples are addressed in the following subsections. These examples are neither the most current nor exhaustive; our aim is to highlight the relevance of laws, rules, principles, etc., in a patent exploitation context.

1.2.4.1 Patent Classification According to the TRIZ Inventive Principles

Various authors have sought to link the patent classification based on the IPC code to the different visions of TRIZ, with the aim of assisting TRIZ users.

Loh et al. (2006) suggest an automatic patent classification using the 40 inventive principles of the TRIZ theory. Through machine-learning techniques, they show the results of classifying according to the first six invention principles from USPTO³ patent documents.

Along the same lines, Li et al. (2012) present a more recent framework that incorporates models from machine learning, data mining, natural language processing, and patent citation metrics to extract patent data and classify them into several categories of inventiveness. They aim to classify patents according to their level of invention, known in the TRIZ context as LOI⁴ (to characterize the creativity of a solution concept). To overcome the common problem in patent searches of the large quantity of nonpertinent patents retrieved, the authors present a framework to assist designers in the selection phase, ranking patents as pertinent or “high value.” The authors hope to integrate their approach into future Computer-Aided Design (CAD) systems to provide designers with the means to find alternative solutions (the most innovative) and to stimulate their creativity in the design phase.

³United States Patent and Trademark Office.

⁴The Level of Invention is defined as the degree of inventiveness, that is to say, the relative degree of system changes compared to a previous system.

1.2.4.2 Applying TRIZ Trends for Technology Transfer and Technology Forecasting

By definition, technology is systematic knowledge applied in order to modify, control, or order elements of the physical or social environment. This includes material systems and regulation and management analysis systems.

When considering the history of our society, we can see that over a long period of time, people have adapted to rapid technological change. Our great-grandparents were born in the age of horse-drawn carriages, then motor transport, they saw the first man walk on the moon, and now they are witnessing the radical change in computers and information technologies. However, despite the impacts of technological change, companies and individuals have not learned much about how to anticipate and plan technology (Roper et al. 2011).

Nowadays, anticipating technology is more than a mere desire; it has become a real need for industries seeking to forecast technological leaps related to their systems and products. *Innovate or die* has become the motto of several companies seeking to survive in a competitive environment. In this context, some researchers are working on the identification of different fields where technologies might be transferred and also on technology forecasting.

For instance, the identification of areas in which a given technology can potentially be applied assumes increasing importance for industries. Park et al. (2013) maintain that companies have insufficient understanding of the potential applications of their technologies in other domains due to the abundance of technologies and technical terminologies in different industrial fields. The authors note that industrial technologies can be linked to different areas of application by applying a functional point of view as the functions used are generally similar. Their approach, based on extracting SAO⁵ structures, allows them to retrieve relevant information which is then transformed into knowledge to be used for future technology transfer. The authors adopted TRIZ evolution trends [redrawn from Mann (2002)] as criteria to evaluate technologies in patents. They claim that TRIZ evolution trends is a useful tool for technology evaluation and forecasting because almost every TRIZ trend follows the basic principle of the TRIZ philosophy, “*Increasing Ideality*,” which means that technology systems evolve towards increasing benefits while reducing harm, and that most technologies and systems evolve only in this direction.

Finally, Technology Forecasting (TF) is a process that anticipates the generic or specific meaning of the technological evolution of a product or family of products, and is focused on inventions and their innovations.

For Verhaegen et al. (2009) TRIZ evolution trends enables them to predict improvements by identifying the “evolutionary potential” of a family of products described by Mann (2003). Their approach seeks to categorize patents according to several known trends (based on the intrinsic skill of TRIZ experts). They analyze

⁵Subject-Action-Object.

patents using an algorithm based on text mining and natural language processing, which extracts relevant information about a product, which is then compared with the TRIZ trends.

They collect the patents concerned (product or family of products) from IPC codes (or other classifications) and the different sections of text in the patent. The patents that are retrieved are then marked (with a tagger) for parts of speech (POS), in order to identify the adjectives. These are then used to identify the TRIZ trends concerned and the trend phases in the patents, a task that is not automatic. The authors say that their method can be incorporated into the product design specification phase to assist design engineers.

There is a real interest on the part of several researchers and industrialists in identifying and classifying evolution trends from patent documents. In more recent studies, Yoon and Kim (2011) describe an automatic approach that consists of extracting binary relations from patents using natural language processing and semantic sentence similarity (or semantic proximity⁶) to then determine the specific TRIZ evolution trends. Their approach lacks some precision in terms of correctly identifying trends. To improve the initial approach, they propose a system for using SAO structures (Park et al. 2012).

A timeline analysis of patents to identify key technological points (density of patents found in a short period) is one of the interesting features of this approach. This enables us to identify promising technologies in areas that are underdeveloped technologically. Based on this method, the authors designed a “Technology Intelligence⁷” tool. The authors claim that this “TrendPerceptor” can analyze large amounts of information from which it extracts what is useful and thus assists designers with decision-making (technology assessment and forecasting) (Yoon et al. 2012).

1.3 Selecting, Analyzing, and Classifying Pertinent Patents for Patent Exploitation

In our previous work (Valverde et al. 2014), we proposed a problem-solving methodology which uses mainly energy-based functional decomposition and physical phenomena to analyze patents iteratively and thus find innovative concepts. This method allows users to select relevant keywords using a detailed analysis of the problem’s main function, related resources (available energies, external environments, space, time, etc.) and related physical keywords through functional

⁶This is the metric defined on a set of documents, terms or concepts. The notion of distance refers to the sense of similarity or semantic content.

⁷Technology intelligence is an activity that allows companies to identify opportunities and threats which could have either positive or negative effects. The aim is to systematically inform companies about the market environment, i.e. the latest techniques, competitors, potential partners, etc.

decomposition and a detailed physical analysis. The relevant selected keywords make up the knowledge base used to launch new searches, which in some cases focus the research and in others expand the research field. Pertinent recovered patents are classified into discovery matrices which can be exploited in timeline, allowing patent analysis in an evolutionary perspective (Valverde et al. 2016b).

This methodology was conceived in the IMC department (Valverde 2015), and brings together some aspects of the department's expertise and acquired knowledge. A brief description of this method is given in the next subsections.

1.3.1 General Description of the IMC Problem-Solving Methodology

The block diagram in Fig. 1.4 shows the procedure divided into three stages, each made up of several blocks or modules. It demonstrates the method proposed to find innovative solutions for a given industrial problem.

The first stage consists in defining the problem and the context. It is broken down into three blocks, the first being a detailed analysis of the function to be achieved, the second covers a thorough search of existing material, and the third relates to the recovery of the initial keywords to create a keyword database (knowledge base). First of all, the function to be processed is described in great detail, as we want to decompose the problem as much as possible in order to gain an exact understanding of the subject. We recover all the initial keywords linked directly to the problem but also to the context itself, i.e., external environments, areas of application, companies involved, etc. Secondly, a search of existing material is carried out, using the recovered and listed keywords. We provide the designer with the means to extend his search area into scientific journals, open archives, patent databases and search engines using automatic search tools designed for this purpose. A keyword database is created at this stage, and it is gradually added to each search iteration and reused to generate new requests.

In the second stage, a structural analysis of patents is carried out and the iterative search continues. The structural part examines in several phases and in detail the knowledge recovered in the previous stage, i.e., technologies and concepts. A single concept can be divided into several concepts represented by several functions. The exhaustive search for relevant keywords begins with an analysis of the functional flow required to carry out the function. The expected functioning will be described in a functional decomposition which will result in the selection of imposed or induced physical phenomena. These physical phenomena make up the knowledge base, along with improvement techniques and associated keywords. The energy-based functional decomposition gives us access to different keywords which lie outside the scope of the initial keywords. They derive from different types of converters from which we can select. This enables us to search for patents in different fields. The patent search based on keywords listed in the knowledge

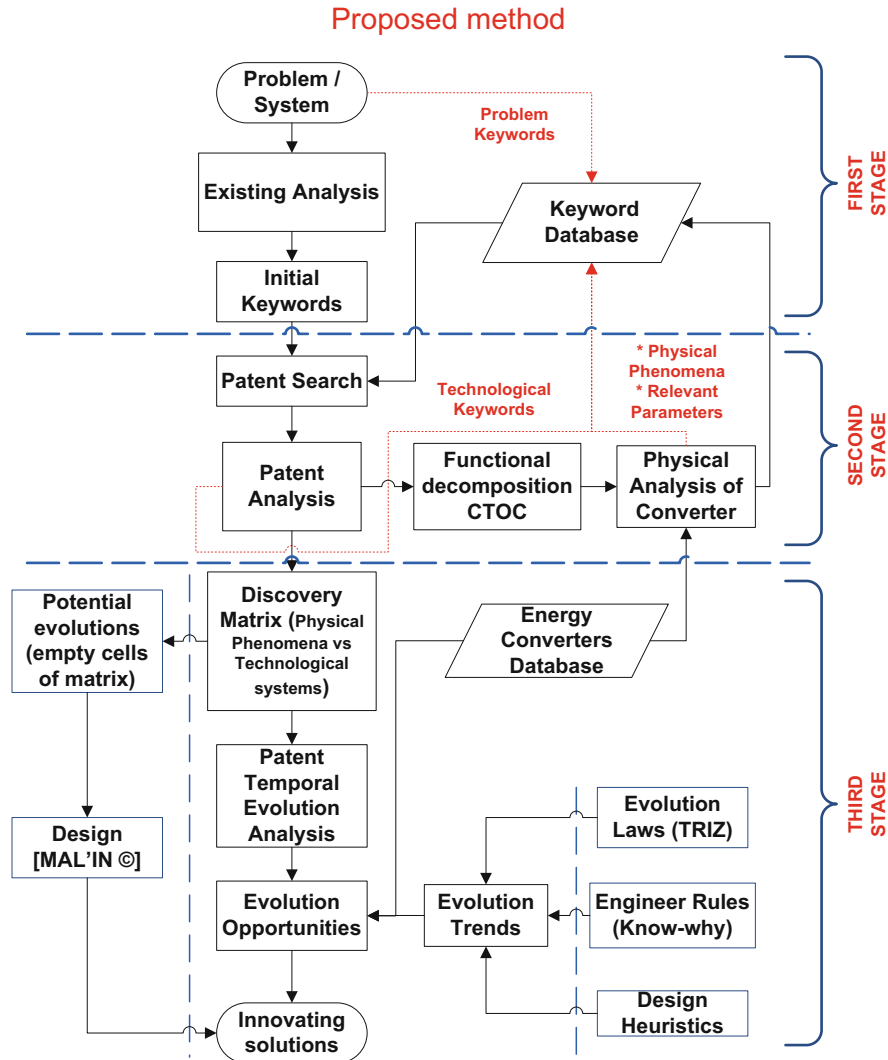

Fig. 1.4 Block diagram of the IMC method

base is carried out using the traditional patent databases. The search is therefore directed and framed. In this stage, a discovery matrix is constructed by crossing physical phenomena and the technological systems retrieved, so that the designer can classify the patents he considers to be pertinent. We then try to deduce evolution opportunities in order to move towards innovative solutions.

The third stage involves our innovation methods. It consists of exploiting the discovery matrix along three axes in order to define evolution opportunities and directions for innovation. First, we analyze empty cells, which correspond to

concepts that are not found, are nonexistent or which lie in the public domain. The possibility must be validated with innovative solutions for problem-solving such as MAL'IN⁸ (Pailhès and Nadeau 2007) (I2M-IMC). Pertinent patents are time-ranked to exploit the discovery matrix by evolution trends of technical systems. The second approach covers analysis by evolution trends constructed from the TRIZ theory evolution laws, rules of the art of engineering, and I2M-IMC design heuristics. The database of the physical effects of energy conversion completes the evolution opportunities in these systems, this is the third approach. This database is also used for the physical analysis in the second stage.

1.3.2 Formatting Patents for Exploitation: Discovery Matrix and the Timeline Classification

The discovery matrix has been presented initially as a classification tool of pertinent patents. It is constructed from a point of view of technologies vs. physical phenomena involved. Once the matrix contains a considerable amount of patents, it can be explored through an evolution trends perspective or from another point of view.

There are various possibilities for exploiting the matrix, i.e., by date of publication, by physical phenomenon, by technology used, by field of application, etc. The chosen classification provides users with various types of information, for example, classification by physical phenomenon shows the different phenomena used in the patented inventions, and reveals which physical phenomena are most used or least used to carry out the principal function.

Given the context of this chapter, it is appropriate to explore the matrix using a timeline to classify the patents. When the matrix has enough elements to analyze (convergence index of the method), we then carry out an in-depth analysis which provides the first opportunities for evolution in order to achieve innovative solutions.

The discovery matrix is used to carry out the timeline classification of pertinent inventions automatically. Figure 1.5 gives an overview of this concept. In certain cases, the timeline classification enables the designer to visualize obvious technological changes, e.g., changes in shape, addition of one or more components, division of elements of the system, etc. In other cases, the changes are less obvious, e.g., change in the frequency of an operation, improvement in energy flow, addition of materials, fibers, fabrics, etc. In all cases, a structured approach must be used to identify technological trends in order to gauge the next “technological leaps” in patented inventions.

⁸Software for inventive problem-solving, based on a method that combines functional analysis with idea-finding tools and concepts extracted from the TRIZ theory.

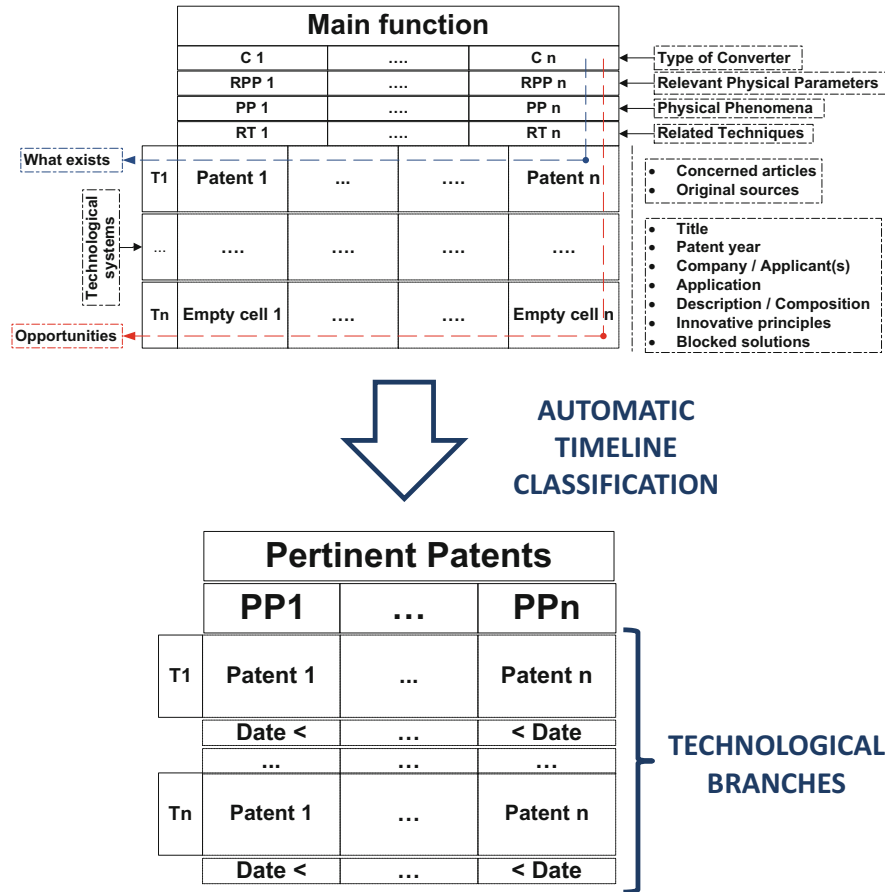

Fig. 1.5 Concept of the discovery matrix and patent timeline

1.4 A Proposition of Evolution Trends

In this section, our proposition of evolution trends is complemented by the rules of the art of engineering. These trends are presented in the form of eight cards which are part of an interactive tool to assist designers (Valverde 2015). To illustrate these trends here, we show some elements of the construction of Trend Four (T4). In the next section, we apply the evolution trends to a pair of technological branches in order to inspire possible hybrid solutions.

1.4.1 *Rules of the Art of Engineering (Engineering Best Practices)*

With several years of education behind them, years of experience in companies and techniques learned in the course of their careers, engineers acquire a specific know-how that we call the “rules of the art of engineering.”

Our evolution trends integrate different professional practices by several professional bodies, the standards used, and research studies and experience acquired by the I2M-IMC department, all of which make up the knowledge base that enables us to find standardized solutions for design or for solving new problems.

To illustrate certain rules, we look very generally at studies carried out jointly by IMC and the company Galtenco Solutions on designing a new generation of pressure vessels for the oil industry.

Martinez (2014) introduces different concepts in the design of a system subjected to external pressure (or external loading). To model the problem, he defines a pressure vessel with two zones, one zone under stress and one zone unstressed. It is the zone under stress that is subjected to external stresses and links with the reference material (e.g., soil), while the nonstressed zone houses technical systems or is used for storage. In this context, he emphasizes the importance of understanding how to direct mechanical flows and absorb strain energy.

He uses various rules of the art of engineering from the department’s knowledge base, of which some examples follow:

- Direct mechanical flow
 - Produce structures with bars working in traction or compression (lattice type); interactions should have a revolute joint behavior.
 - Produce shut-down systems and distribute stresses via segmented arcs which arch when compressed.
 - Produce granular areas to distribute stress locally.
 - Produce taut structures.
 - ...
- Produce a structure that is deformable locally to absorb strain energy and rigid overall for stability.
- Favor behavior in traction or compression for rigid structures and flexion behavior for deformable areas.
- ...

Table 1.5 shows an adaptation of several rules based on the work of Martinez. It covers various systems/technologies used as a source of inspiration in the design of a new generation of deep offshore pressure vessels (and which can be extrapolated to other issues). We are particularly interested in the design rules, some of which are included in our evolution trends.

It is important to clarify the main difference between heuristics and the rules of the art of engineering; the former describe proven findings, while the latter have a physical basis.

Table 1.5 Excerpt from engineering best practices related to pressure vessel design (Martinez 2014)

Domain/ Field	System/Object/ Product	Properties	Best practice
Aerospace and defense	Ceramics	Fragile nature, refractory properties, compressive strength, hardness	Prestress and/or confine ceramics to control their brittle behavior
Civil engineering	Segmented Arc (“Voussoirs” in French)/other modular elements	Discontinuous component at the microscopic level, mainly trapezoidal or rectangular geometry, usually made of concrete, etc.	To ensure the stability of the modular building elements, set up an external load that causes over-center locking (arching or “arc-boutement” in French) between components
Offshore and nuclear industry	Reinforced concrete vessel	Concrete has a fragile nature	Place steel bars to avoid shearing, preload them to increase performance
Deep water exploration	Ceramic submarine	Ceramic has a fragile nature, metal replacement for structural elements (steel and titanium)	To avoid bending stresses, split into several parts and introduce mobility
Military	Sandbags or Earthbags	Discontinuous component at the microscopic and macroscopic level, they do not have a linear-elastic behavior, low resistance facing tangential stress	Place fibers to avoid shearing
Pressure vessel	Stiffeners	Internal, external, rigid or deformable stiffeners, tubes, strips, sandwiches, mesh, honeycomb, composite, steel, etc.	Segmentation of the mechanical flow
Armors	Ceramic armor	Hardness, sintered material or powder, sometimes chemically bound to metals, plastics or composites	Prestress and/or confine ceramics to control their brittle behavior

1.4.2 Introduction of the Eight Cards of Evolution Trends

As we have already established, our eight evolution trend cards represent eight TRIZ theory evolution laws, some elements from the 12 groups of Polovinkin’s rules, several design heuristics, and several engineering best practices from different areas. They will be very useful in evaluating the different classified technologies that were found in the timeline of the patent analysis phase of the discovery matrix. Table 1.6 summarizes and provides a description of each group. Note that this classification is very similar to the eight TRIZ laws, because we have taken the foundations of these laws and expanded the original definition.

Table 1.6 Description of eight groups of the IMC evolution trends

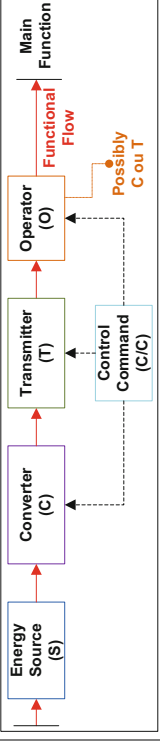
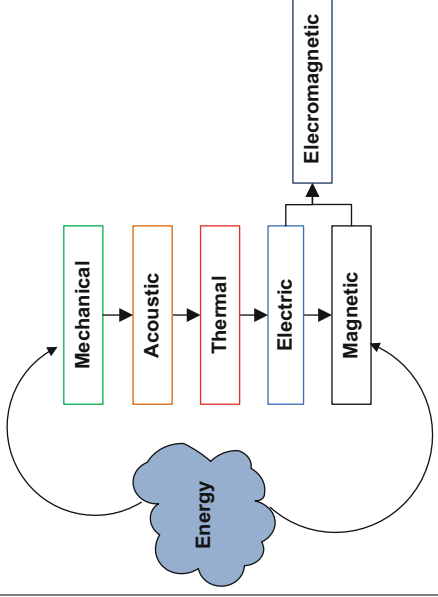
T	Title	Description
1	Source-Converter-Transmitter-Operator-Control/Command (SCTOC)	<p>The realization of a function requires an energy source (internal/external). This energy is converted (converter), transmitted (transmitter), and used to carry out the action (Operator). A Control/Command entity ensures the correct performance of the main function</p>  <p>The diagram illustrates the SCTOC process. It starts with an Energy Source (S) providing Energy 1 to a Converter (C). The Converter (C) outputs Energy 2 to a Transmitter (T). The Transmitter (T) outputs Energy 2 to an Operator (O). The Operator (O) outputs Energy 3 or 2 to the Main Function. A Control Command (C/C) block is connected to the Converter (C), Transmitter (T), and Operator (O). A dashed arrow labeled 'Possibly C ou T' points from the Control Command (C/C) block to the Operator (O).</p>
2	Energy conductivity	<p>A good system should effectively ensure the free passage of energy flow through the SCTOC components</p>  <p>The diagram shows a cloud labeled 'Energy' at the top. Below it, a sequence of boxes represents energy conversion stages: Mechanical, Acoustic, Thermal, Electric, and Magnetic. Arrows indicate the flow from Mechanical to Acoustic, Acoustic to Thermal, Thermal to Electric, and Electric to Magnetic. Below the Magnetic box is an arrow pointing to an 'Electromagnetic' box. A curved arrow at the bottom indicates a feedback loop from the Electromagnetic box back to the Energy cloud.</p>
3	Coordination of the rhythms	<p>The precondition for the evolution of a technical system is the voluntary matching or mismatch of the frequency, oscillations, vibrations, periodicity, or resonance of all parts of the technical system</p>

<p>4</p> <p>Increased level of perfection</p>	<p>Every system evolves by increasing its complexity and must then be simplified</p>	
<p>5</p> <p>Uneven development of the entities</p>	<p>Each entity of the system has its own evolution (nonuniform development of the system elements). The more uneven the evolution of entities, the more complex the system becomes. An entity that reaches its peak blocks the evolution of the system. Reducing complexity will simplify solving the technical and physical contradictions created</p>	<p>(continued)</p>

Table 1.6 (continued)

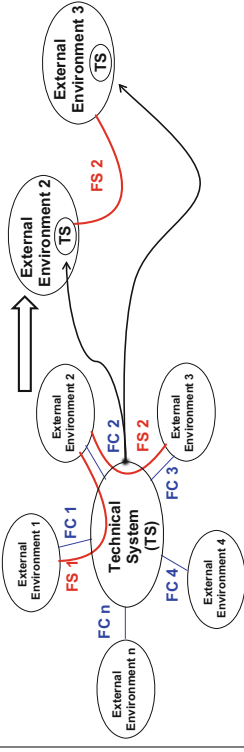
T	Title	Description
6	Transition to the external environments	<p>The evolution of a system goes towards the elimination of what is not requested in order to keep only what is strictly necessary. Eliminating what is not requested leads to the removal of external environments. At the end of the process, the initial product is absorbed by the last two external environments involved in the main function. Intermediate evolutions can occur by exchanging functionalities with the external environments</p> 
7	Transition from macro-level to micro-level	<p>Once an operational entity cannot be improved at the macro-level, it is still possible to make it evolve at the micro-level. The concept of macro- and micro-levels is directly related to the observed structural level (solid, granules, powder, gel, liquid, mist, fields, molecules, atoms, ions, electrons, etc.). This trend leads to increased use of immaterial fields which replace the physical entities</p>
8	Increased dynamism and level of controllability	<p>To expand or increase the efficiency of a system, its entities must evolve from static to dynamic (movable) to increase their controllability. Various stages of evolution are possible: Uncontrollable entities become controllable, mechanical fields are replaced by electromagnetic fields, entities become mutually compatible. Generally, the evolution of the system moves towards a reduction in human intervention</p>

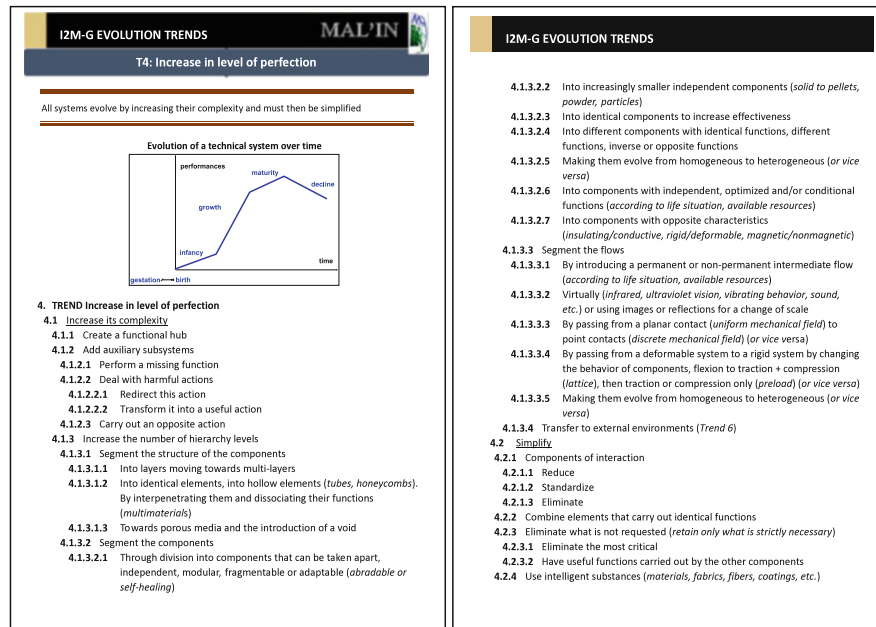

Fig. 1.6 Example of card showing evolution of trend four (T4)

As an example, Fig. 1.6 shows the card for trend four (T4). The increase in the degree of perfection establishes that all systems evolve by increasing their complexity and must then be simplified. This trend is illustrated with the different life stages of a technical system, from its birth until its decline.

On this card, design heuristics and rules of the art expand the level of detail of some evolution laws, giving us a more accurate view of the possible evolution of the technical system.

The S-curve in Fig. 1.6 is analyzed as follows: the first part concerns the birth of the product, i.e., the creation of the functional core, and then the product must evolve to reach new markets. In order to do this, it must increase in complexity to acquire new functions. Then, to retain its markets, it must become more simplified. The card defines the different stages and possible solutions.

The beginning of the evolution is an increase in complexity as the system must become multifunctional while avoiding any harmful effects. The performance of new functions will add auxiliary subsystems (T4.1.2). These auxiliary subsystems (T4.1.3) are necessary to perform any missing function while avoiding any adverse effects (TRIZ). These actions will then lead to the setting up of hierarchies and, of course, this will be with the aid of segmentation methods. The I2M-IMC heuristics already described will then be used to complete the trend analysis by classifying the segmentation of the structure of the components, the segmentation of the components or of the flows. The refinement of the different segmentation possibilities is borrowed from the rules of the art of engineering. We next come to simplification

(T4.2), which will reduce complexity by eliminating components or reducing them to a micro-level. The first components concerned are interaction components, which must be reduced, standardized, then eliminated. Next, the functional components are first segmented in the first phase, and must then be recombined or eliminated to retain only what is strictly necessary. Lastly, the final reduction consists in searching for solutions at the micro-level by using new materials which already incorporate functional possibilities.

The evolution trend cards are useful to assess technological evolution followed by technical systems found in relevant patents. In order to facilitate their use, the cards form part of an interactive tool that allows designers to browse more efficiently through the different trends.

The seven remaining cards can be found in doctoral studies by Valverde (2015). Concerning the application case of the bi-phasic separators, the utility of these evolution trends will become clear when pertinent patents are analyzed along a timeline.

1.5 Application Case: Deep Offshore Biphasic Separator

1.5.1 Context of the Problem

The application case relates to a biphasic separation system in deep offshore. Nowadays, offshore oil processing, at ever greater depths, has led the industry into the design of complex separation systems. Designers must develop separation systems with reduced mass and volume and improved performances, i.e., residence-time, slug⁹ management, etc.

Several factors must be considered when devising a new biphasic separation system. Among the most important are:

- Hydrates or crystallized salts.
- Management of sand entrained by fluids.
- Thermal fluids (avoid cooling the liquid in order to prevent hydrate formation).
- Slug management: At low liquid and gas flow rates, the flow regime is generally stratified, with the gaseous phase flowing at a faster rate above the liquid phase. At higher flow rates, the gas may be entrained in the liquid and waves are formed at a gas-liquid interface. When they fill the cross section of the pipeline, these waves form liquid slugs. As the flow rate of the gas phase is generally much higher than that of the liquid phase, the liquid slugs are accelerated by the gas phase to the same velocity. Such liquid slug flow regime can cause unstable conditions and handling problems for downstream installations.

⁹Sporadic production of liquid and gas.

There is extensive literature on the design of biphasic separators for use upstream of the multiphase pumps. A large number of patents and articles dealing with the subject indicate that no separator with satisfactory performance has yet been achieved (Tor et al. 2012).

1.5.2 Structuring the Discovery Matrix and the Timeline Classification

Structuring the discovery matrix is possible once the first and second stages of the IMC methodology have been carried out. Performing these two stages gives us, first, a collection of pertinent patents selected and analyzed by designers. Second, several technical and physical concepts are recovered through an iterative implementation of functional decomposition and a detailed physical analysis. In the following section, we present the structure and elements that form one discovery matrix related to biphasic separators.

1.5.2.1 Discovery Matrix Columns and Lines Structure

Concerning the structure of columns, Table 1.7 shows, in general, the physical phenomena involved in separating a biphasic mixture, looking at the dominant liquid flow and the dominant gas flow. The discovery matrix is made up of the type of converter, the pertinent physical parameter, the physical phenomena, and the associated techniques.

The principal function of the matrix is defined as the separation of biphasic mixtures. Different types of separation have been identified (fluid dominant and fluid entrained), i.e., Liquid/Gas, Gas/Liquid, Liquid/Liquid, Liquid/Solid, Gas/Solid, etc. Table 1.7 considers only two cases to illustrate the method and the structure of the matrix. The last part of the structuring will be to cross the families (technological branches) of technologies found (Table 1.8) with the pertinent physical parameters and phenomena.

The lines of the discovery matrix are structured in five branches identified during the iterative phase of research and analysis of the IMC method. In Table 1.8, each branch or “technological family” is complemented by special features found when analyzing patent documents; they generally refer to the shape of the components (Fig. 1.7).

1.5.2.2 Discovery Matrix Timeline Classification

As previously mentioned, the discovery matrix may now be exploited either by physical phenomenon or by patent release date. In the context of this study, it is

Table 1.7 Columns of the discovery matrix, biphasic separators G/L and L/G case

Separation of biphasic mixtures: G/L case				
Gas/Liquid				
Converters (Cs)	Relevant physical parameters (RPP)	Physical phenomena (PP)	Related techniques (RT)	
Static	ρ^a	Archimedes principle ^b		
Dynamic	ρ , Υ^c and Compactness (C^d)	Liquid inertia	Translation	Displacement in the opposite direction to movement of gas
			Rotation	Centrifugal
		Drop ^e		Limit friction
		Impact/Shock	Debonding	Dissociation
		Coalescence	Vibration	
Separation of biphasic mixtures: L/G case				
Liquid/Gas				
Cs	RPP	PP	RT	
Dynamic	ρ , Υ and C	Diffusion	Pressure gradient	
			Rotation	Centrifugal
		Impact/Shock	Perpendicular to flow	In the flow direction
		Coalescence	Demister ^f	
			Vibration	
		Deflection/Deviation	Centrifugal ^g	
Thermal gradient	Condensation			

^a Density

^b Gas/Liquid friction opposed to a buoyant force

^c Acceleration

^d Ratio between surface and volume

^e Used as a resource, the law of gravity

^f Removes entrained liquid droplets in a vapor stream

^g Change in direction

relevant to display pertinent patents in a timeline classification with their related technologies ordered in technological branches (B) (Fig. 1.8). This classification is performed automatically using IMC method tools. Through this kind of arrangement, different technology changes or evolutions followed by biphasic separation systems can be deduced by simple observation and a brief analysis. To illustrate this general analysis by observation, consider two technology branches, vessels (branch 2) and cyclones (branch 4):

- Decantation tanks. In our classification, we see that from 1973 systems were already using deep offshore with heat exchangers to control fluid thermics (GB1309826). In 2003, we continue with gravitational systems which are hybrids with systems using other separators to manage entrained sand (hydrocyclones) (WO03078793). Until 2012, we see a change in shape and also the introduction

Table 1.8 Lines of the discovery matrix, biphasic separators, G/L and L/G case

Separation of biphasic mixtures				
Gas/Liquid and Liquid/Gas				
Branch 1	Branch 2	Branch 3	Branch 4	Branch 5
Helices, Spirals, Helical section, Propellers	Cyclone, Hydrocyclone, Venturi	Bulkheads, Baffles, Deflectors, Fins, Trays, Blades, Pipes, Tubes, Plates	Container, Reservoir, Tank, Vessel	Various: Heat Exchanger, Electrostatic (Electrodes), T-Junction, Chemical Agent
Characteristics				
Variable pitch, spiral, etc.	Cone, Cylinder (“Rotary”), etc.	Inclined, Circumferential, Maze, Snail Shell, Guidance, Curved, Rotating Stairs, Helical Spiral, Verticals, etc.	Sedimentation, Settling, Decantation	Combination of various technological systems (in our classification, fewest of these were found)

of elements inside the decantation tanks to improve their performance (US2012000643).

- Cyclones and hydrocyclones. In 1987, a rotational system (vortex type) appeared that separates oil droplets from water (US4702837). In 2000, we had hybrid systems based on cyclones and other components (i.e., electrodes) (WO0074810). In 2004, several hydrocyclones were used in parallel to optimize the separation process (EP1393812). Then in 2011, hydrocyclone systems (in series or in parallel) incorporate chemical agents (US2011042288). In general, we observe the use of cyclone systems downstream from other separation systems.

A more structured analysis using the evolution trends must be performed in order to deepen the analysis of concepts, decipher the potential technological leaps, inspire us with new ideas, and identify evolution opportunities or innovative solutions (if they exist).

1.5.3 Exploiting the Discovery Matrix by Means of Evolution Trends

The five technological branches (families) classified in the discovery matrix can be exploited now through an evolution trends perspective. A general analysis of these branches, as we have seen in the examples, shows an evolution over time, i.e., the shape, the arrangement of components, materials, etc. The evolutions followed by these branches are analyzed and compared with our knowledge base and then translated into evolution trends. To illustrate this point in the following subsections,



















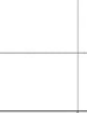

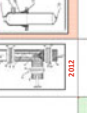
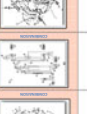







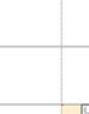















DISCOVERY MATRIX BYPHASIC SEPARATION Liquid / Gas											
Type	Relevant physical parameters	Static (ρ)			Dynamic (ρ, ν and compactness)						
		Archimedes			Liquid inertia			Drop	Collision	Coalescence	Vibration
Physical phenomena	By				Rotation						
Technology					Translation						
Pitch helices / Spiral / Helical Section	Technology										
		2004	2004	2004	2004	2004	2004	2004	2004	2004	2004
Cyclone/Hydrocyclone /Venturi/Cone cylinder ("rotary")	Technology										
		2002	2002	2002	2002	2002	2002	2002	2002	2002	2002
Wells / wells / Archimedes / Helices / Spiral / cones / cones / Tanks / small shells / circumferential / Lab yreth / small shells / Guidance / Cones / Transitions / Helical / spiral / Vertical	Technology										
		2006	2006	2006	2006	2006	2006	2006	2006	2006	2006
Miscellaneous / Combination (Heat exchanger / Separator (Cyclone) / Transition / Chemical Agent)	Technology										
		2012	2006	2002	2002	2006	2006	2002	2002	2006	2006
Container / Reservoir / Tank	Technology										
		2012	2006	2002	2002	2006	2006	2002	2002	2006	2006

Fig. 1.7 Example taken from discovery matrix of biphasic separators (predominantly liquid stream) (Green useful, orange might be useful, red not useful, white not defined)

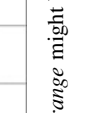
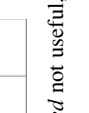
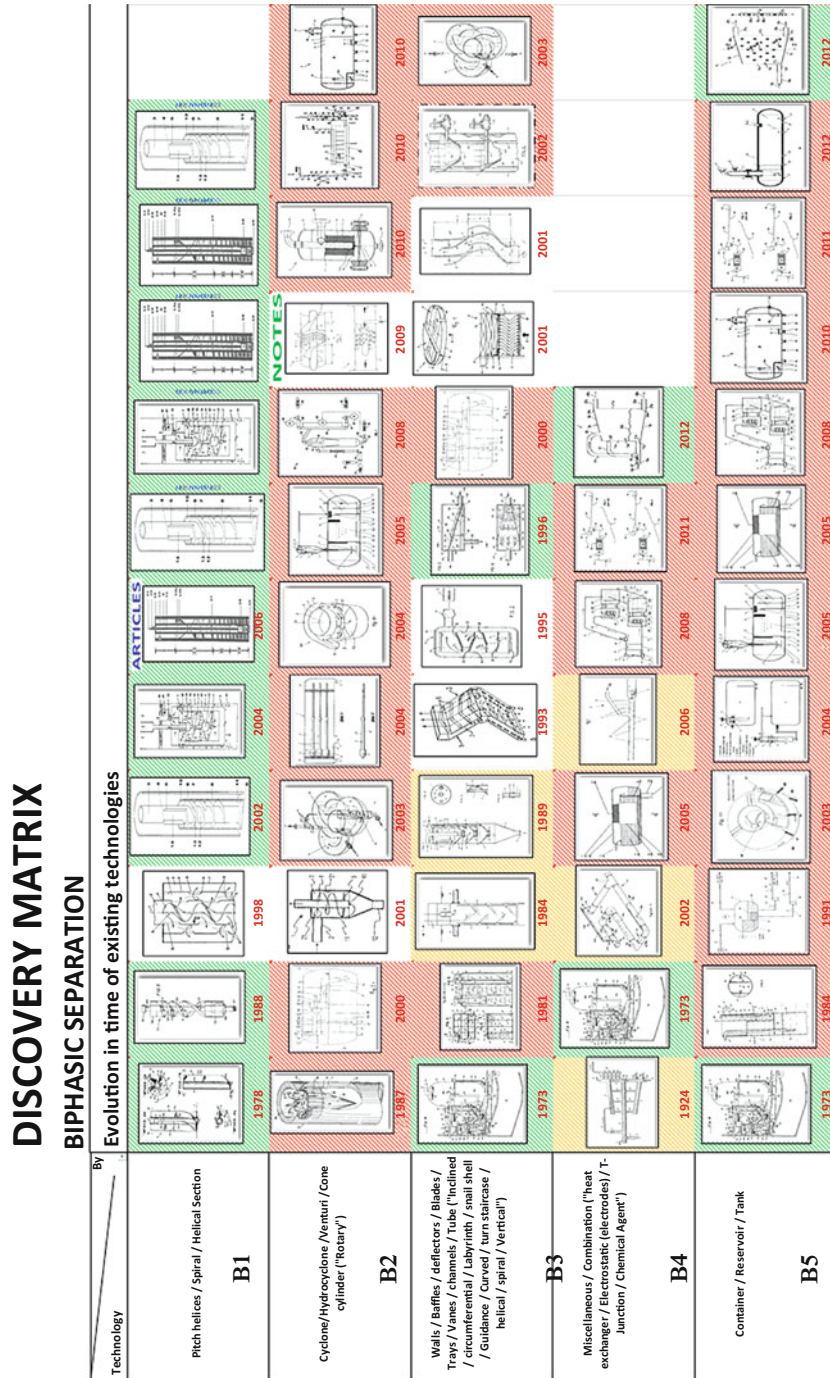

Fig. 1.8 Excerpt from patent timeline classification (Green useful, orange might be useful, red not useful)

we analyze branch 1 (helices, propellers, etc.), branch 3 (trays, deflectors, plates, etc.), and branch 4 (hybrid systems, combinations, etc.).

1.5.3.1 Analysis of Helical Systems (Branch 1)

From 1978 to 2006 (Fig. 1.9), patents dealing with biphasic separation by helical systems followed trend 6 (transition to external environments), T6.3 to be precise (evolving towards bi-poly-systems). In fact, we noticed that while the 1978 patent (CA1036077) consisted of a single type of helix with uniform pitch, all the others had several propellers with different characteristics.

Let us analyze the changes in each patent or group of patents according to the other trends (T1–T8).

A study of the completeness of the system (T1—Source, Converter, Transmitter, Operator, and Control) produces the following observations for all patents:

- The converter is always a pump.
- The transmitters are static.
- Separation is never controlled; this is an important area for change.

All helical systems generate losses through friction. Any reduction in these losses (T2—Energy conductivity) will favor systems that avoid systematic contact between the droplets and the metal structures, i.e., as soon as the droplets have been separated, they must be evacuated. Patent DE19650359A1 (Fig. 1.10a) recovers the droplets laterally, which reduces displacement. Patent RO119248B1 (Fig. 1.10b) uses gravity to help eliminate the droplets. The next change will be to eliminate these losses completely by letting the droplets fall (concept used in systems with plates).

The coordination of rhythms (T3) was present from the second patent that we found. There were double helices (in phase), helices with uniform pitch, and inverted helices (out of phase). These variations in pitch modified the displacement dynamics of the mixture. There are no dynamic components in these offshore systems; this avoids any problems in maintenance.

We noted that the complexity of the separator increased over time (T4—Increased level of perfection). Segmentation (T4.1.3—Increase the number of hierarchical levels) was used a lot, as mentioned previously. It is essential to incorporate hierarchy levels in order to avoid the risk of clogging due to the short-term transportation of large quantities of liquids (slugs), in other words, to anticipate when large volumes enter the system. We note that a hierarchy is in place in 2006 (Fig. 1.11) to deal with this problem: at the entrance the pitch of the helix is very steep. See Fig. 1.11 for an explanation of the hierarchy levels.

At first sight, trend T5, unequal development of entities, is not seen in the succession of patents in Fig. 1.9. If we put the systems into the context of offshore, we see that the helix diameters are small, which segments the separators. Offshore, having many separators is not an option. We therefore want a small number or even a single separator. There is therefore a contradiction associated with the

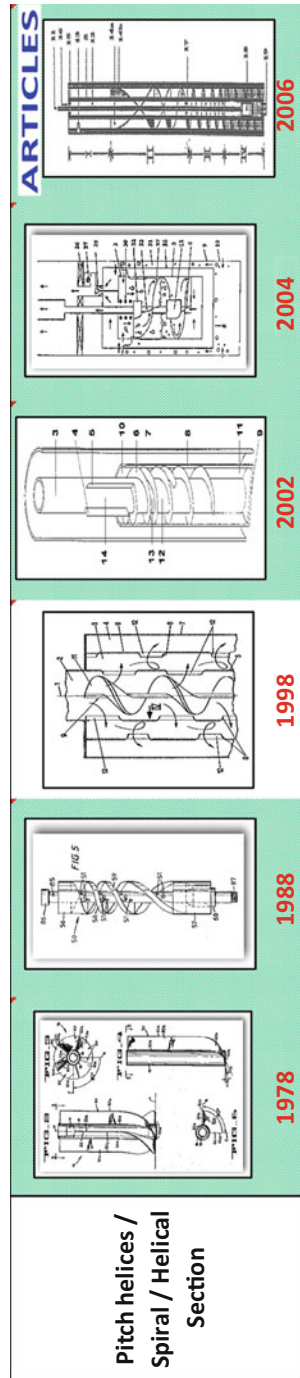

Fig. 1.9 Excerpt from the timeline of patents that contain helical elements (B1)

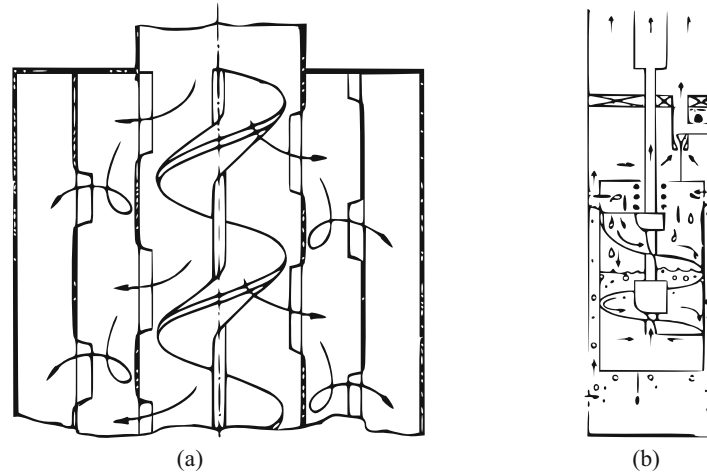

Fig. 1.10 (a) Patent DE19650359A1 (1998)—lateral recovery; (b) Patent RO119248B1 (2004)—recovery from below

development of small-diameter helices. For the concepts in our context to evolve, this contradiction has to be resolved.

There is no development expressed at the micro-level (T7—Transition from macro-level to micro-level) in the patents.

Trend T8 concerns the increase in dynamism and the level of controllability. From the beginning, we have seen that it is difficult to control separation efficiency. We must look at the effect of the evolution of the helices on separation. We note that the systems increase their dynamism by varying the shape (T8.4) of the helix and by segmentation which modifies the rhythm of droplet displacement up to Fig. 1.11, which includes two inverted helices with variable pitch (T3.1.2—Coupling in phase opposition). The increase in controllability now involves using new fields by superimposing effects that will initiate collisions and allow the droplets to coalesce. These fields, high frequencies for example, will be controllable.

1.5.3.2 Analysis of Plate Systems (Branch 3)

We now analyze patents involving plates Fig. 1.12. These patents have reached the public domain or will soon do so as the most recent is dated 1996.

Plate systems fall within trend T6 (Transition to the external environments), they have identical components with the same functionality to increase efficiency (T6.3.1), components that are following the concept of segmentation.

Analysis according to trend T1 (Source, Converter, Transmitter, Operator, and Control) is the same as for the helical systems, i.e., a lack of control.

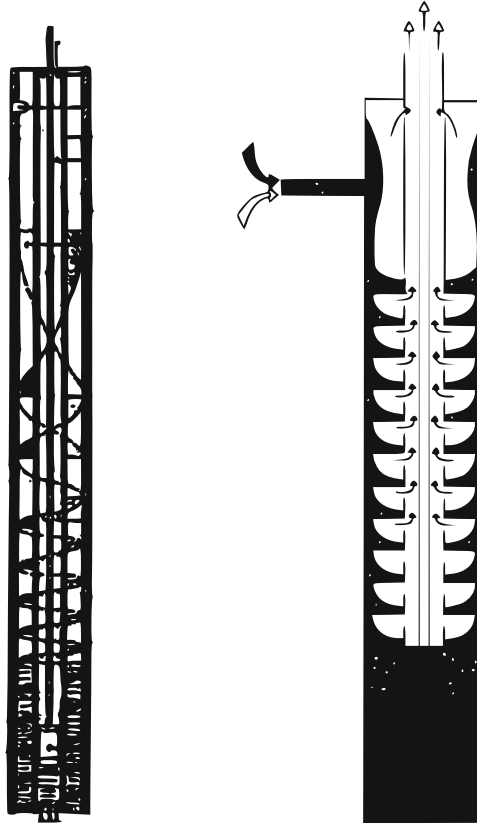

Fig. 1.11 Patent MY123978 (A) (2006): incorporation of hierarchy levels (Rosa et al. 2001)

However, energy losses (T2—Energy conductivity) are less as this is a hybrid concept: sliding along the plates and a drop between two plates, thus the liquid remains in contact with the plates for only a short time.

Apart from these two possibilities (slide and drop), no change in rhythm can be seen, which could be the case with changes in pitch. Similarly, there is no use of additional vibrating systems. Thus from the point of view of trend T3 (Coordination of the rhythms), there are possibilities for developments.

Increase in the level of perfection (T4) concerns segmentation, which is characteristic with plates (division into several entities, T4.1.3.1). This segmentation has evolved in the latest patents (Figs. 1.13a and 1.14) by incorporating the drilling of holes which will calibrate the droplets and cause them to fall. As in the case of the helical cyclones, the last patent (Fig. 1.14) includes management of the separation tables.

We observe no uneven development (T5) or transition to the micro-level (T7).

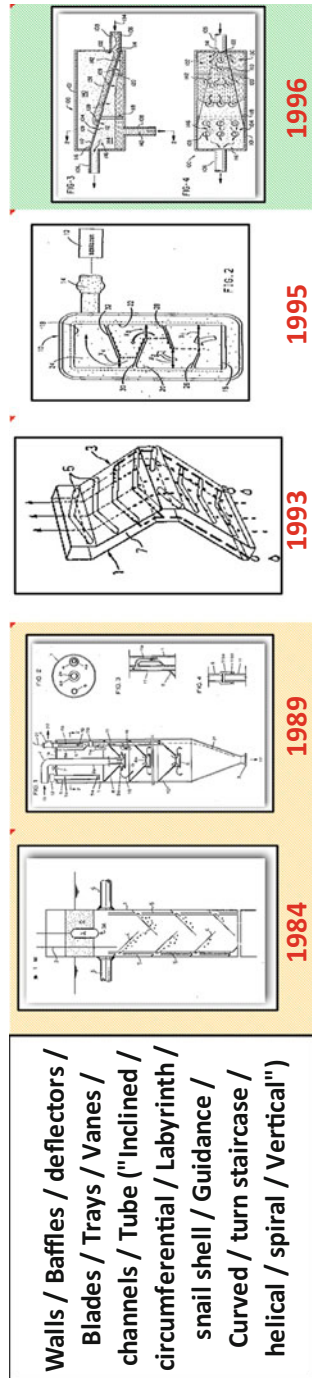
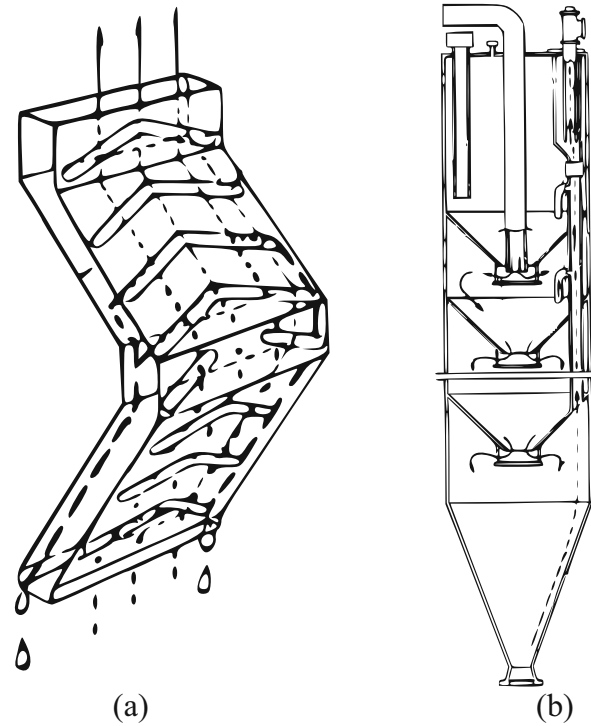

Fig. 1.12 Excerpt from the timeline of patents containing plate elements (B.3)

Fig. 1.13 (a) Patent DE4214094C1 (1993) Slugs management; (b) Patent US4816146A (1989): changes in shape



As was the case for the helices, we observe an increased dynamism as a result of change in shape (T8.4), from 2D to 3D (T8.4.4) until we find concave shapes (Fig. 1.13b, T8.4.3).

We paid particular attention to a patent invention from 1996 (Fig. 1.14) which is composed of polysystems and which is able to control slugs by means of an inverted plate.

1.5.3.3 Analysis of Hybrid Systems (Branch 4)

In this branch, we analyze patents concerning the combination of different concepts that produce hybrid systems to increase efficiency in the biphasic separation process. The combination of different technological systems allows designers to overcome the numerous constraints involved in offshore processes. Figure 1.15 shows branch 4, where we mainly identify storage tanks and T-junction systems combined with heat exchangers, storage tanks with hydrocyclones combined with chemical agents or high power electrodes, etc.

Fig. 1.14 Patent
US5507858A (1996): Slugs
management

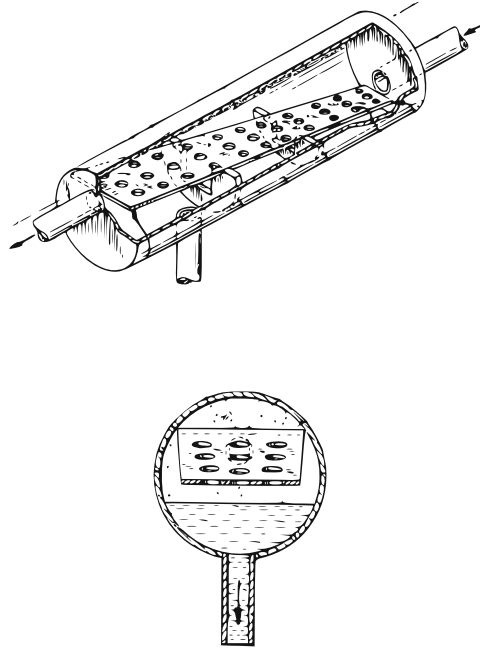

Once again, the evolution trends help us in qualifying the main changes observed in patents with the aim of being inspired by the technical solutions found in the technological branches.

In biphasic separation, we identify two main axes used in subsea facilities: gravity (i.e., settling tanks) and centrifugal (i.e., cyclones) separation. In the 1970s, a third axis was formally observed: the biphasic separation by T-junctions. They attracted great interest among petroleum engineers, as many T-junction systems have been used in the vast networks of pipelines in offshore processes for separating biphasic mixtures (de Oliveira 1992). They are considered ideal systems in subsea installations because of their simplicity, the limited number of components needed, their possible reuse in other exploitation fields, and a simplified control. These systems achieve an efficiency of separation of 85%; however, they are extremely sensitive to two-phase flow behavior (Margaris 2007). In the technological branch 4 of Fig. 1.15, we observe that T-junction systems appeared in 1924 for stratifying two fluids; in 2002, they were used to dissipate fluid slugs from gas pipelines; and in 2006, we identified several vertical degassing pipes. In this time span, we find again Trend 4 (Increased level of perfection), particularly the increase in the number of hierarchical levels (T4.1.3) and segmentation (T4.1.3.1). From 2008, we began to observe the integration of different systems for different functions (T6.3.4), which means T-junctions combined with sedimentation tanks and centrifugal components organized in modular sections. Lastly, in 2012, we continue with the integration of various systems (T6.3.4) such as Tanks,

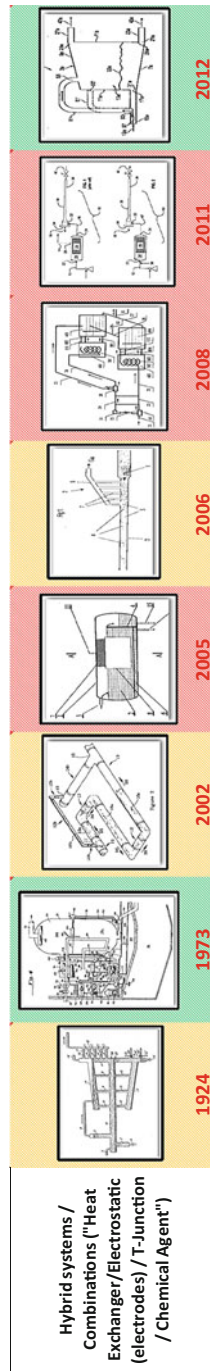

Fig. 1.15 Excerpt from the timeline of patents containing hybrid systems (B4)

T-junctions and Plates. We also note an evolution of the form (T8.4) through a modified settling tank adapted to deep offshore facilities (Compact separator) and several small tanks (segmentation principle, T4.1.3.1) linked in series to form a multi-stage separator to resolve the deep sea and slug problems, respectively.

Another hybrid concept is the integration of heat exchangers in order to thin liquids. Observing branch 4, we note in 1973 a system that combines settling tanks and heat exchangers for separating a three-phase mixture (gas, water, and oil). Heating is an interesting track because it allows prevention of the formation of hydrate plugs.

More interesting hybrid concepts found in branch 4 are the integration of high-voltage electrodes combined with settling tanks and baffles (2005). This invention uses an electrostatic field to promote drops coalescence. We note here the transition from a macro-level to the micro-level (T7) by the use of electric fields (T7.4.7). Finally, in 2011, we identified several settling tanks connected in series or in parallel (Segmentation T4.1.3.1), hydrocyclones (the vortex inside generates a centrifugal force), Coalescers (filters or baffles) and chemical agents to promote coalescence in the mixture. The chemical coalescent agents (polymers) or de-emulsifiers are used to coalesce insoluble particles (T7.4.6—Replace/Overlay mechanical flow by another, i.e., chemical, optical, acoustic, etc.).

1.5.4 Innovation Through the First Findings

The analysis of technological branches (from the discovery matrix classified in the timeline) using the evolution trends enables us to objectively identify trends followed by the patented inventions over time. This also gives some initial ideas and possible directions for innovation by taking into account the best solutions and looking toward hybridization (where several concepts are combined to carry out the desired function). Evolution trend analysis can also lead us to completely change the concept using new technologies.

1.5.4.1 Incremental Innovation: A Hybrid Solution

Our hybrid concept is illustrated in Fig. 1.16; it represents one of several possible conceptual solutions proposed to the oil industry. This hybrid concept is an alternative proposal to the use of a cyclone or a common settling tank (currently the most used).

Let us go over the essential concepts retrieved when analyzing by evolution trends: first, the incorporation of identical polysystems to increase the efficiency of an action (T6.3.1); next, trends toward segmenting one entity into several entities (T.4.1.3.1); then incorporating different systems with identical functions (T.6.3.2).

The constraints of working offshore generate a contradiction if we are using cyclones; our first proposal was based on the use of plates as this enables us to have

Fig. 1.16 First two-phase separator proposal

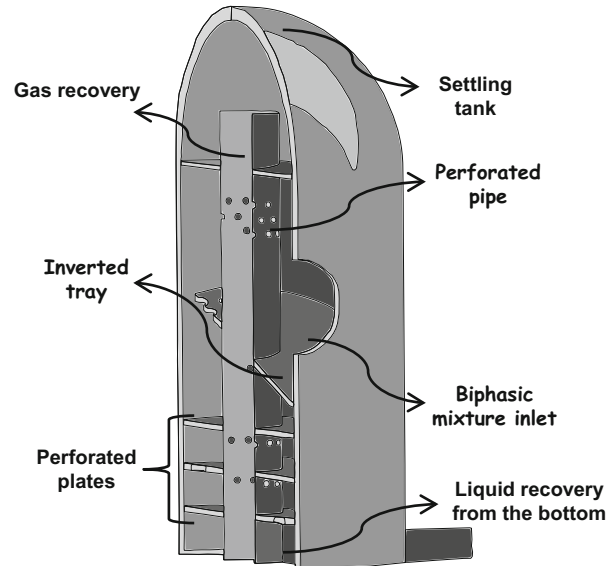

large diameters. Another restriction imposed by the oil industry was the use of settling tanks as those currently installed. Therefore, we should make a proposition based on an incremental innovation. The concept that was presented to the contractor involved a hybrid system, a gravity settling tank with plates, where fluid recovery is done from the bottom.

We start by taking relevant concepts found through patent analysis by evolution trends. Figure 1.16 shows a settling tank that incorporates horizontal perforated plates in order to refine the mixture separation; this concept was previously seen in Fig. 1.13 (trend towards identical polysystems—T6.3.1 and segmentation—T4.1.3.1). The mixture inlet is at the top, which means that it can then drop, thus promoting separation. The recovery of gas is done by means of a central tube; this solution is inspired by the lateral and internal recovery of Fig. 1.10a. Lastly, an inverted tray manages slug formation from the biphasic mixture due to the deceleration of the fluid; it also has perforations to promote biphasic separation before entering the horizontal plates where mixture separation will continue. This concept was inspired by the 1996 patent (Fig. 1.14) which will soon enter the public domain.

1.5.4.2 Breakthrough Innovation: Future Ideas

As seen previously, patent analysis by evolution trends offers us several interesting tracks that could inspire engineers in the design of a new biphasic separation device in order to go beyond what has been done up till now. The hybridization of

technologies is a clear trend (T6.3.4) observed throughout the timeline of the discovery matrix. Work might continue on the integration of different solutions to increase separation efficiency, which could lead us to the reduction or even the elimination of components, thus increasing the level of perfection in the system (T4). In the timeline, we also observed a trend going from a macro-level to a micro-level (T7) which implies the replacement of physical components (static or dynamic) by fields. The application of an electrical field to improve biphasic separation is a current trend which will be increasingly used in the future.

1.6 Conclusion and Discussion

We have produced evolution trend cards for technical systems based on the TRIZ evolution laws, Polovinkin's rules, design heuristics by the I2M department and the rules of the art of engineering. These cards are used to analyze evolution opportunities based on the knowledge derived from studying pertinent patents. Selecting the pertinent patents was based on a method perfected by the I2M research institute. It is presented here in the form of a discovery matrix which crosses patented technologies with the physical phenomena involved in or suggested by the method.

By applying the technique to the design of a liquid/gas separator for deep offshore, the relevance of this analysis becomes clear. Directions for technological systems (lines of the matrix) or physical possibilities (columns of the matrix) were observed. The timeline classification and the trend cards indicate possible developments. By crossing solutions we were able to propose hybrid solutions, one of which is illustrated here.

Our aim now is to ensure the completeness of our evolution trends proposal by applying other design rules. It would be worthwhile to test our trend cards against the communities currently working on patent exploitation and thus measure their degree of detail in design activities.

Work is currently under way to improve searches in more substantial databases and by using special algorithms (Valverde et al. 2016a). To develop the information in our cards, further studies are needed based on different industrial fields, and this work has already started (transformation of marine energy and telescopic access platforms).

References

- Altshuller GS (1984) Creativity as an exact science: the theory of the solution of inventive problems. Gordon and Breach Science Publishers. Available via <https://books.google.fr/books?id=ejJIIIj5m-UC>
- Altshuller GS (1994) In: Shulyak L (ed) And suddenly the inventor appeared TRIZ, the theory of inventive problem solving. www.triz.org

- Altshuller GS, Seredinski A (2004) 40 principes d'innovation: TRIZ pour toutes applications. Seredinski (Avraam). Available via <https://books.google.ca/books?id=emiLGQAACAAJ>
- Calle-Escobar M et al (2014) Heuristics-based design process. *Int J Interact Des Manuf (IJIDeM)* 1–18
- de Carvalho MA, Wei T, Savransky SD (2004) 121 heuristics for solving problems. Lulu Press Inc., USA
- Julien C (2000) Histoire de l'humanité. UNESCO, Paris
- Li Z et al (2012) A framework for automatic TRIZ level of invention estimation of patents using natural language processing, knowledge-transfer and patent citation metrics. *Comput Aided Des* 44(10):987–1010
- Loh HT, He C, Shen L (2006) Automatic classification of patent documents for TRIZ users. *World Patent Inf* 28(1):6–13
- Mann D (2002) Hands-on systematic innovation. CREAX Press, Ieper
- Mann DL (2003) Better technology forecasting using systematic innovation methods. *Technol Forecast Soc Change* 70(8):779–795
- Margaris DP (2007) T-junction separation modelling in gas-liquid two-phase flow. *Chem Eng Process Process Intensif* 46(2):150–158. Available via <http://linkinghub.elsevier.com/retrieve/pii/S0255270106001528>
- Martinez I (2014) Conception Innovante d'un réservoir à pression pour l'offshore profond. Bordeaux
- de Oliveira PJDSP (1992) Computer modelling of multidimensional multiphase flow and application to T-junctions. PhD Thesis, University of London
- Pailhès J, Nadeau J-P (2007) Innover en conception par les Méthodes d'Aide à L'INnovation MAL'IN. In: 7ème Congrès International de Génie Industriel. Troisrivières, Canada
- Pailhès J et al (2011) Energy based functional decomposition in preliminary design. *J Mech Des* 133(5):51011
- Park H et al (2012) A patent intelligence system for strategic technology planning. *Expert Syst Appl* 40(7):2373–2390
- Park H, Ree JJ, Kim K (2013) Identification of promising patents for technology transfers using TRIZ evolution trends. *Expert Syst Appl* 40(2):736–743
- Polovinkin AI (1988) Fundamentals of engineering creativity – for students of technical colleges. Mashinostroenie, Moscow
- Polovinkin A (1991) Theory of new technique design: laws of technical systems and their application. *Informelektro* 98–102 (in Russian)
- Roper AT et al (2011) Forecasting and management of technology. Wiley, New York
- Rosa E, França F, Ribeiro G (2001) The cyclone gas-liquid separator: operation and mechanistic modeling. *J Pet Sci Eng* 32(2–4):87–101. Available via <http://www.sciencedirect.com/science/article/pii/S0920410501001528>
- Salamatov YP (1996) A system of laws of technology evolution (Basics of the theory of technical system evolution), 2nd edn (in Russian). Institute of Innovative Design, Krasnoyarsk. Available via <http://www.trizmink.org/e/21101000.htm#toc>
- Savransky SD (2000) Engineering of creativity, introduction to TRIZ methodology of inventive problem solving. CRC Press, Boca Raton
- Savransky SD, Wei T-C (2001) Comparison of Polovinkin's heuristics with Altshuller's principles. *TRIZ J*. Available via <http://www.triz-journal.com/comparison-polovinkins-heuristics-altshullers-principles/>. Accessed 29 Sept 2015
- Savransky SD, de Carvalho MA, Wei T-C (2000) 100+ heuristics for systems transformations: a brief report of US Patent fund study. *TRIZ J*. Available via <http://www.triz-journal.com/100-heuristics-systems-transformations-brief-report-us-patent-fund-study/>. Accessed 29 Sept 2015
- Scaravetti D (2004) Formalisation préalable d'un problème de conception, pour l'aide à la décision en conception préliminaire. Arts et Métiers ParisTech
- Tor B, Torbjoern F, Bjoernar W (2012) Gas-liquid separator. United State patent US2012/000643

- Valverde U (2015) Méthodologie d'aide à l'innovation par l'exploitation des brevets et des phénomènes physiques impliqués. PhD Thesis, École Nationale Supérieure d'Arts et Métiers
- Valverde U et al (2014) Innovation through pertinent patents research based on physical phenomena involved. In: 24th CIRP design conference, 21, pp 515–520
- Valverde U, Virapin D et al (2016a) Incorporation of energetic functional decomposition and evolution trends in a technology intelligence approach. In: Virtual concept International Workshop 2016, major trends in product design, Bordeaux, France, 17–18 March. Springer
- Valverde U, Nadeau J-P, Scaravetti D (2016b) A new method for extracting knowledge from patents to inspire designers during the problem-solving phase. *J Eng Des*. doi:[10.1080/09544828.2017.1316361](https://doi.org/10.1080/09544828.2017.1316361) (in press)
- Verhaegen P-A et al (2009) Relating properties and functions from patents to TRIZ trends. *CIRP J Manuf Sci Technol* 1(3):126–130
- Yoon J, Kim K (2011) An automated method for identifying TRIZ evolution trends from patents. *Expert Syst Appl* 38(12):15540–15548
- Yoon, Janghyeok, Kim K (2012) TrendPerceptor: a property-function based technology intelligence system for identifying technology trends from patents. *Expert Syst Appl* 39(3): 2927–2938
- Zouaoua-ragab D (2012) Lois d'évolution de TRIZ pour la conception des futures générations des produits: Proposition d'un modèle.