



**HAL**  
open science

## Premixed flames in microgravity

Daniel Durox, Roger Prud'Homme, Philippe Scoufflaire

► **To cite this version:**

Daniel Durox, Roger Prud'Homme, Philippe Scoufflaire. Premixed flames in microgravity. Combustion Experiments during KC 135 Parabolic Flights, ESA SP 1113, 1989, 92 9092 008 4. hal-02172979

**HAL Id: hal-02172979**

**<https://hal.science/hal-02172979>**

Submitted on 11 Nov 2020

**HAL** is a multi-disciplinary open access archive for the deposit and dissemination of scientific research documents, whether they are published or not. The documents may come from teaching and research institutions in France or abroad, or from public or private research centers.

L'archive ouverte pluridisciplinaire **HAL**, est destinée au dépôt et à la diffusion de documents scientifiques de niveau recherche, publiés ou non, émanant des établissements d'enseignement et de recherche français ou étrangers, des laboratoires publics ou privés.

# PREMIXED FLAMES IN MICROGRAVITY<sup>1</sup>

D. Durox, Dr. R. Prud'homme, P. Scouflaire

CNRS/Laboratoire d'Aérotbermique, Meudon, France

## 1. INTRODUCTION

The influence of gravity on combustion phenomena is well known with regard to diffusion flames but it is more difficult to assess in the case of premixed flames. Although gravity can easily be considered in the equations, it has always been difficult to measure its exact influence on experiments. It is fairly certain that gravity has no influence on strongly turbulent flames in fast flow, but this is not true for match calmer flames in rather slow flows.

One of the main questions as far as combustion is concerned has always been to measure the laminar flame speed of fuel mixtures, and practically all the different methods used are hampered by gravity. One classical technique is to enclose the mixture in a pipe and to ignite it at one end. The laminar combustion velocity is then determined since the flame speed and the flame area are given. However, researchers have always observed that the shape of the flame was influenced by the direction of propagation in the vertical pipe and that it caused imprecisions in measurements. According to Combourieu [1] the downward propagation is much less stable and makes measuring more difficult. The front shapes are quite different in both cases with a match flatter profile when the flame is downward. Two additional effects exist which are difficult to control: a pressure increase in the tube and wall effects. Hamins et al. [2] in very recent study, measured the propagation speed of the flame, both upward and downward by igniting the mixture in the middle of the pipe and by controlling the pressure perfectly by means of a system of valves in plastic film. They found that the upwards flames ran faster than the downwards ones especially with extraordinarily rich or very lean mixtures. On the other hand, like Combourieu [1] they found no notable influence of gravity on the laminar flame speed. It must be noted, however, that their measurements of the laminar flame speed are different in the vicinity of stoichiometry according to the size of the pipe showing edge effects.

As far as we know there are very few studies on premixed flames in microgravity, and the ones being made are carried out in a drop tower and mainly deal with the problems of ignition and extinction of lean flames [3]. Ronney's study, [ focussing on the same phenomena, shows that gravitational forces have stabilising effect on flames spreading upwards. Studies on flame instability and particularly on cellular flames must also be mentioned since gravity has a stabilising effect on both phenomena. This can be proved by equations anti confirmed by experiments [5], [6].

However, experimental conditions on the ground is never perfect and therefore the effect of gravity cannot be correctly analysed. We think it interesting to observe Bunsen-type flames in microgravity at different pressures and with different mixture controls for three reasons: The first being to observe the effect of gravity on the flame shape, the second to see how the oscillation of the peak (visible on the ground for rather high flames) behaves during the period of microgravity, and the third to observe how rich enough flames (equivalence ratio >1,4) behave when there is no buoyancy effect.

---

<sup>1</sup> Published as the Chapter 1 of "Combustion experiments during KC-135 parabolic flights". ESA SP-1113. ISBN 92-9092-008-4 August 1989.

## 2. EXPERIMENTAL SET-UP

The experimental equipment has been devised in such a way that it could be used cooperatively by scientists from Bochum University, Imperial College and from

ESTEC. The other experiments bore upon a hot gas turbulent jet and upon combustion of solids.

Thus the main part of the system created by us has been made available to various experimenters.

A general view of our set-up is pr in photo 1. All the regulation and security control devices are up in a control desk (photo 2) fixed on to the structure.



*Photo 1. Experimental equipment.*

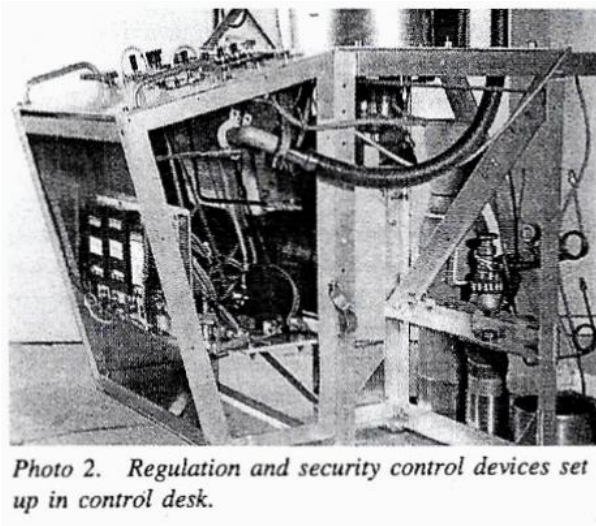

*Photo 2. Regulation and security control devices set up in control desk.*

### 2.1. Chamber and support

The system (see figure 1) is about 1.80 m high in all. The floor surface occupied is about 1x0,50 m and the total weight is 95 kg.

The combustion chamber (figure 2 and photo 3) - called multi-user combustion chamber or M.U.C.C. - is composed of a double stainless-steel wall. The inner wall is 1.5 mm thick and the outer wall 1.2 mm. The total height is 1m and the inner diameter is 0.3 m. Four portholes show easy optical access, two of them have a useful diameter of 150 mm, one a diameter of

120 mm and the last one a useful diameter of 200 mm. The latter is set up on a hinge and can thus be opened rapidly by means of four thumb screws. The panes are 19 mm thick and they are externally covered with a plastic-coated film resistant to explosive shocks and high temperatures. Four joining pipes of 40 mm diameter are drilled in one generatrix of the chamber and allow the installation of wires, probes, and various appliances.

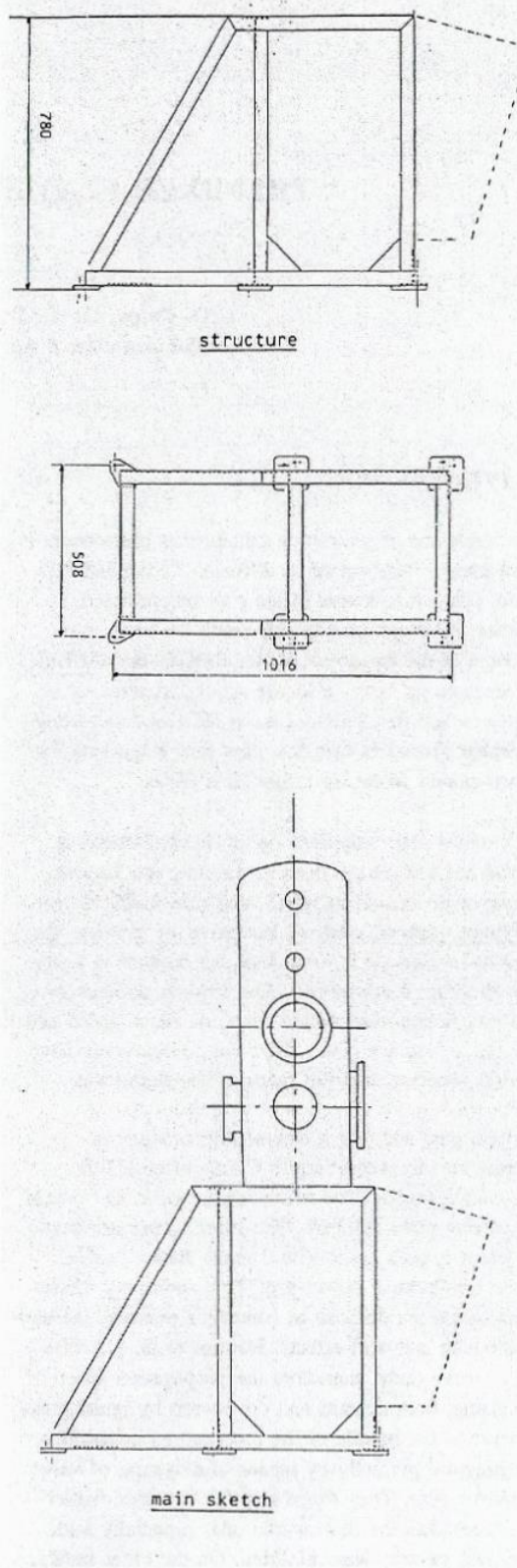

Figure 1. Sketch of the system.



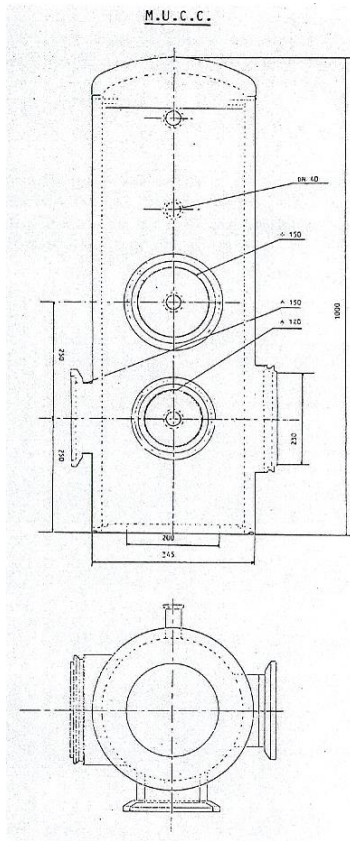

Figure 2. Multi-user combustion chamber (M. U C C.).

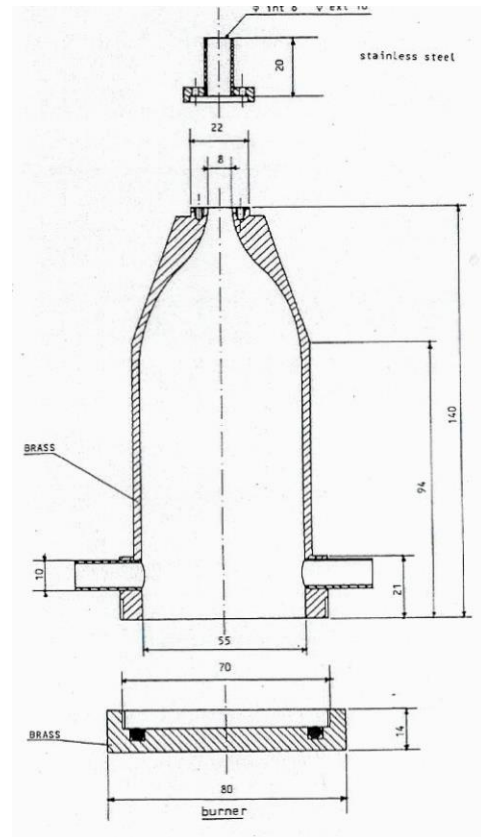

Figure 3. Cutaway view of the burner.

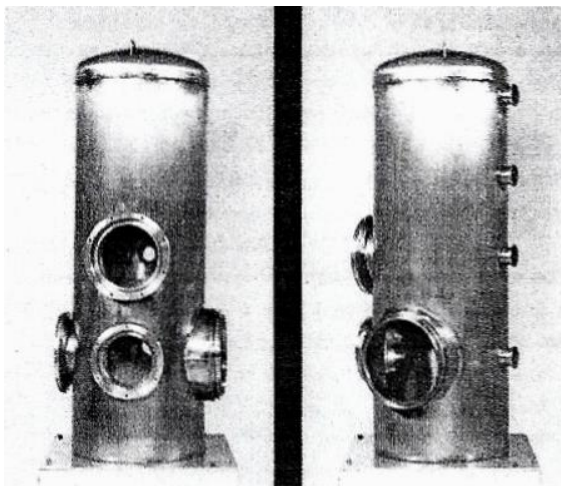

Photo 3. M.U.C.C.



Photo 4. The burner.

The chamber bottom is closed by a 19 mm thick duralumin circular plate which supports the various experiments provided. It can easily be removed in a downwards direction by means of three screws.

O-rings make the chamber leak-proof. It is tested to 6 bars anti to vacuum with the plate closed.

The structure is built with welded duralumin sectional planes, calculated in such a way that the whole frame can resist 9 g longitudinally and 3 g transversely. Holes made at the base of

the structure allow it to be fixed to the floor of the plane. Three gas bottles of reduced capacity (two cylinders of 1 m<sup>3</sup> and one of 50 l) are housed in the support of the structure.

## **2.2. Burner**

The Burner is shown in photo 4 taken through the porthole and its section is represented in figure 3. The main part is made of brass and the top of stainless steel. The lower part of the burner is closed by a screwed brass bottom. The gas enters through two diametrically opposed pipes. An extremely high converging ratio (area ratio = 47) provides a laminar flow and results in a very flat speed profile at the exit. The exit diameter is 8 mm.

The burner is fixed to the chamber closing plate with piezo electric ignitor at its side (photo 4) set on quarter-turn rotary engine which allows the flame to be lit at the beginning of the experiment. The gas pipes go through the plate into a 1 liter spherical premixing chamber located just under and attached to the plate so that the experiment can be changed quickly. The gas enters this chamber through two opposite pipes out of line with the diameter of the apparatus so that they create a cyclone inside.

## **2.3. Gas circuit**

Figure 4 shows a synoptic sketch of this circuit. There are three channels, the first coming from a fuel gas cylinder, (methane in this experiment campaign), the second from an air cylinder and the third from nitrogen cylinder to flush the experiment chamber quickly with a neutral gas.

There are pressure reducers on top of the three cylinders, as well as quarter-turn valves in the

different circuits which make it possible to cut off all the gas inlets quickly, and ten manual turn valves to adjust the fuel gas and air flows accurately. The nitrogen flows into the fuel pipe just before the premixing chamber and its inlet valve can be turned easily by any operator.

An electro valve, the electric functioning of which will be explained in the next paragraph, can automatically shut off the fuel inflow.

Gases are evacuated out of the plane through vent line. There are two possible exits from the chamber, one is equipped with a pressure regulator in order to keep an adjustable pressure inside the chamber, the other has been installed for safety reasons and allows by means of a manual quarter-turn valve a direct connection of the inside of the chamber with the outside of the plane where the pressure is very low (around 0.3 atm at 10000 m). Some tests showed that in cases of emergency it only takes two or three seconds to bring the pressure down to the level of pressure outside the plane.

A safety valve is fitted on the vent line parallel to the pressure regulator. It is adjusted to 1.5 bars absolute pressure and can create a direct connection with the outside of the plane should the pressure in the chamber reach this value.

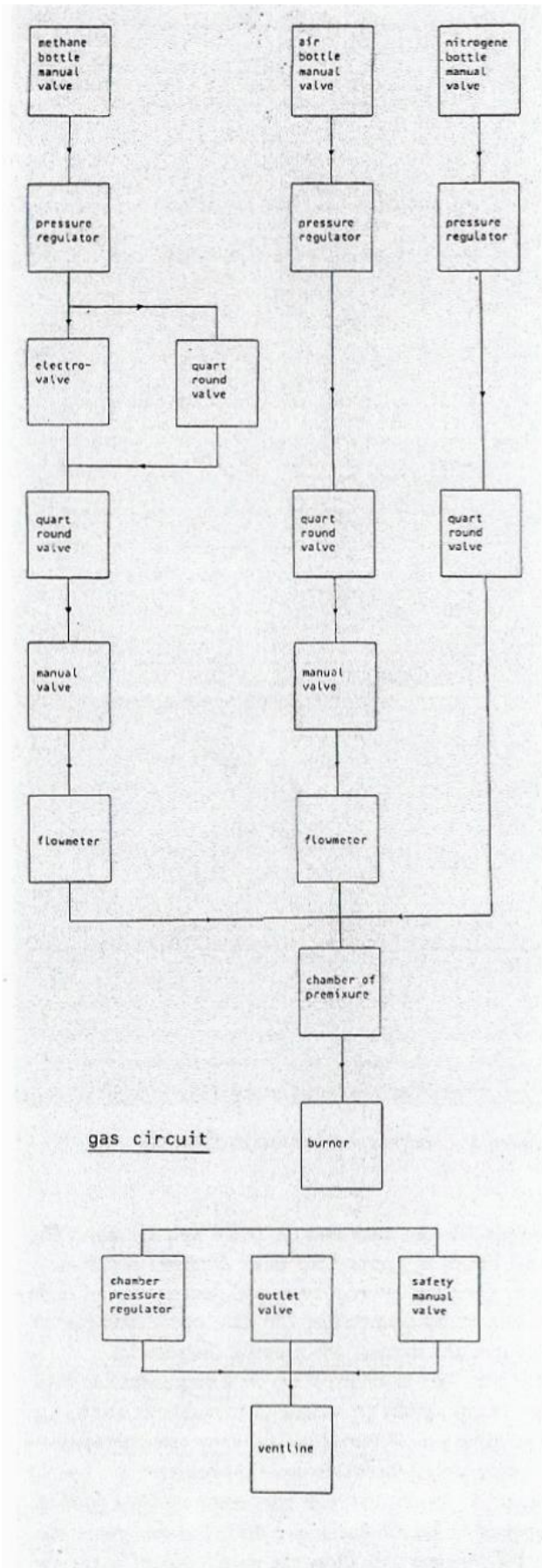

Figure 4. Synoptic sketch of the gas circuit.

## 2.4. Electric circuit and various safety means

A synoptic sketch (figure 5) shows the feeding of the different appliances. The two flow meters as well as the pressure regulator are supplied in 15 V (DC). The digital displays on the control desk are supplied by + 5 V DC. The quarter-turn engine which sends the igniter over the burner works in + 28V DC and is controlled from the desk (photo 5). The spark from the piezo electric is produced by an electronic igniter which is fed by a 9 V battery. The electronic igniter creating the high voltage is fixed inside the chamber so that interference inside the plane is avoided.

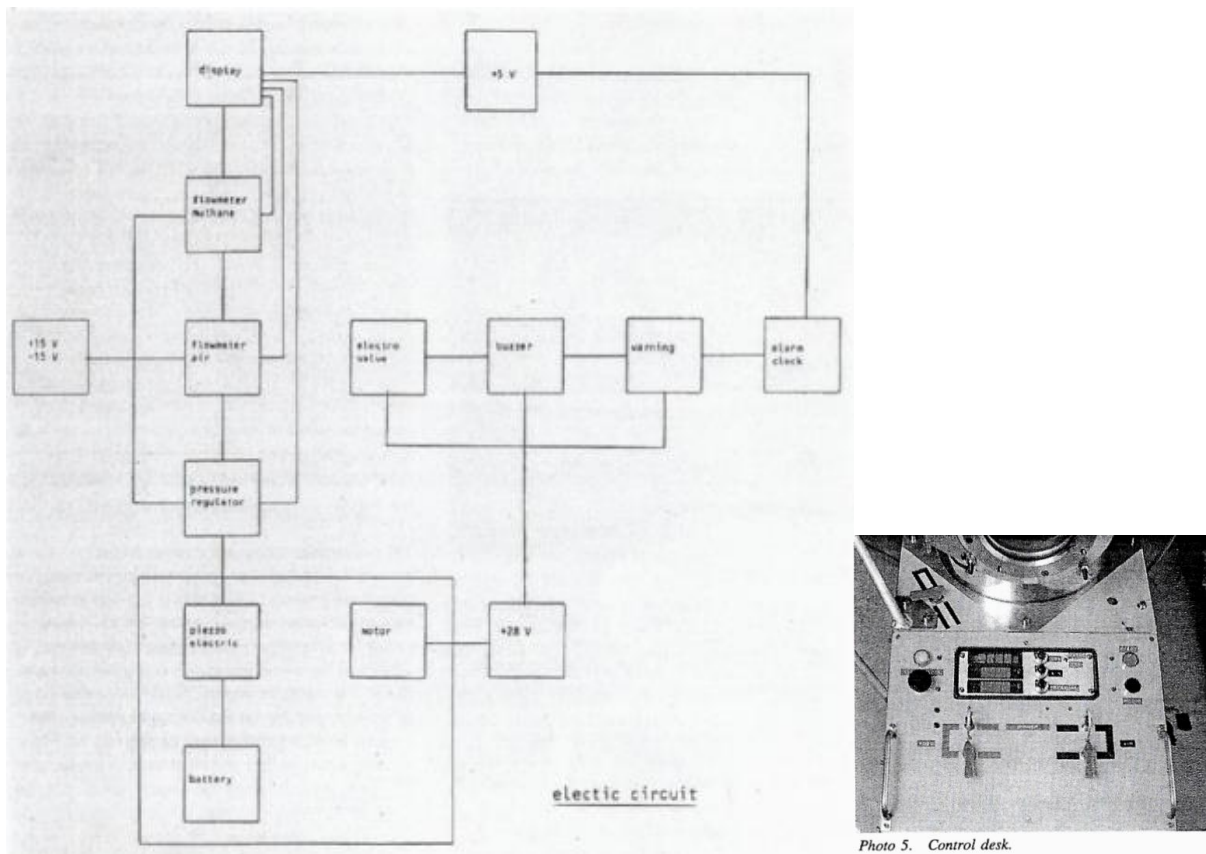

Figure 5. Synoptic sketch of the electric circuit.

An electric safety device is fitted on the fuel circuit (figures 4 and 5). It consists of a + 5V DC electric clock which has to be reactivated every 45 seconds. If this is not done during this interval, a sound alarm will go off and a lamp will light up on the control desk 15 seconds after triggering of the two systems. If there is still no intervention the electro-valve fitted on the circuit will close the circuit and will open only if the clock button is reengaged' to reactivate the system.

The electro-valve works with + 28V and is automatically shut off in the absence of feeding.



### 3. EXPERIMENTAL PROCEDURE

It has been decided, that on reaching the flight altitude the flame should be kept burning, if possible, during the whole duration of the experiments. in order to limit ignition procedures to a minimum.

As the chamber is small it is necessary to preheat the portholes in order to prevent the formation of too much condensation and to maintain good visibility. This is done from the outside of the chamber with an air heater which runs for a few minutes every quarter of an hour. This appliance is supplied with a 110V alternating current available in the plane.

The first stage of the ignition consists in connecting the appliances, the valves being closed. At about two minutes before the first parabola, the gas bottles (methane and nitrogen) are opened, and the pressure is adjusted to the required level in the chamber with the pressure regulator. Then the ignition procedure follows which involves opening the air circuit and adjustment of the flow, rotation of the igniter over the burner, setting of the clock, opening of the fuel-gas circuit and the ignition itself. Once die flame is properly stabilised, finer adjustments are being made according to the desired experimental conditions.

During the whole experiment a video film is shot with an 8 mm camera fitted in front of a porthole (photo 1). The battery allows shooting for 1½ h without interruption.

The various adjustments are made during the horizontal flight and kept constant during the whole time of the parabola. This makes it possible to have view of the flame at 1 g and at 0 g, but alto at 2 g during die ascent and descent phases of the plane. The duration of the parabola is about 1 min, that is to say 20 s at 2 g during die ascent, 20 s at 0 g at the parabola top and 20 s at 2 g during the descent. The 2 g are a perpendicular to the floor of the plane.

### 4. RESULTS

25 parabolas were flown during the April 21st, 1987 flight. The flame was blown out once just before the fourth parabola and it was blown out during the 0 g (zero gravity) period of the twenty first. Something interesting occurred at the twentieth parabola, the flame went out just before the ascent and it was possible to rekindle it without any difficulty or particular phenomenon in comparison with the kindling at 1 g. A table showing the results of this experiment in more detail can be found at the end of this paper (page 9).

Five series of experiments were made. The first was made a 1atm. with rich flames (1.6) reducing the flows at each parabola. The film shows that these flames are relatively drawn out and that there is a significant vertical vibration at the top on an area of about 1 or 2 mm during the 1 g phase, the vibration appearing to have rather a low frequency (a few hertz or a few dozens of hertz). During the 2 g phase, during both ascent and descent, the vibration increases la frequency but without apparently changing its amplitude. The flame is shown during parabola 1 in photo 6. For the first three parabolas at zero gravity the top vibration stops

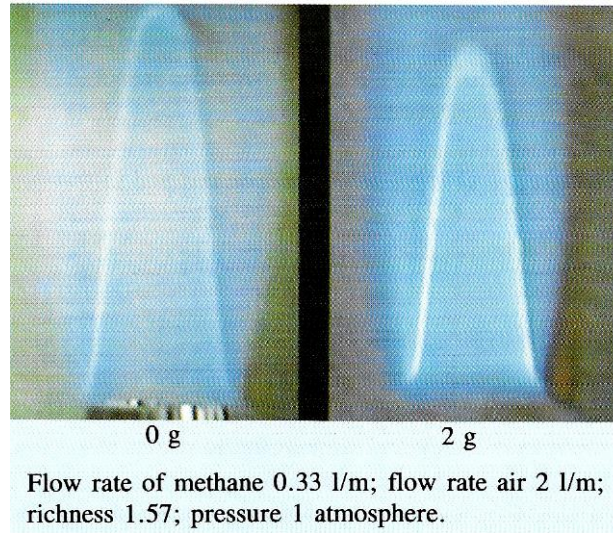

*Photo 6. The flame during parabola 1.*

completely and the flame swells and stretches upwards. It may have gigantic proportions and then go down but it remains bigger than a 1 g. The swelling movements appear to be awfully slow and totally random, a possible explanation being that the microgravity condition is not constant, not always stable and that it may provoke random movements of gas pockets. It is nonetheless true that an important enlargement of the flame surface is observed when dealing with a rich and rather a long flame. The flame vibration of the top is undoubtedly due to stretching provoked by the passage of extremely hot gas flows accelerated upwards by the buoyancy forces. The cause could also be an unstable system generated by the presence of burnt gas downstream the flame front which, after a while, rises faster as it is replaced by somewhat colder air, which modifies the thermic losses at the front of the flame and as a consequence the laminar flame speed.

The second series (parabolas 5 to 11) deals with the influence of the total flow at constant pressure (0.9 atm) and at an equivalence ratio close to stoichiometry (1.05). An example is

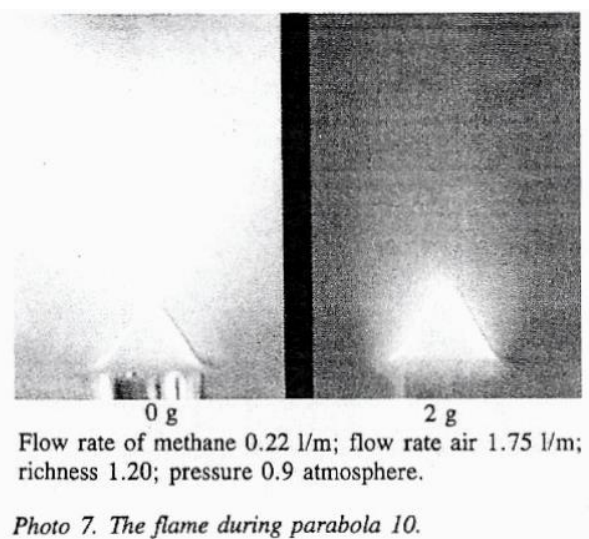

*Photo 7. The flame during parabola 10.*

shown in photo 7 taken during the 10<sup>th</sup> parabola. There is no vibration at the top as can be seen with the naked eye. (It does not mean that it does not occur with flames of equivalence

ratio 1, for it is possible to provoke vibration by increasing the flows considerably and as a consequence the sizes of the flame, but this has not been done during this campaign).

When watching the film sometimes noticeably light lateral movements of the flame during the 0-gravity period can be observed. A comparison of the flame heights between 2 g and 0 g shows that in this experimental configuration the flame is always slightly smaller and more condensed at 0 g than at 2 g. This phenomenon corresponds to a slightly faster laminar flame speed at 0 g. It has not yet been possible to measure this difference in speed precisely. It must also be noted that the top of the flame appears to have slightly longer curvature radius at 0 g, but this may be due to the fact that the flame is smaller.

The third series (parabolas 12 to 16) deals with flames with a constant equivalence ratio (1.05) and with flames at variable pressures (0.65 to 1 atm). The conclusions are the same as those concerning the previous series with slightly smaller flames at 0g. There does not appear to be any particular effect of the pressure in the passage 0 g - 2 g - 1 g.

In the fourth series (parabolas 17 to 20) the flows were varied, and the constant equivalence ratio (1.05) was maintained as well as the pressure between 0.65 and 0.7 atm. The same shortening effect of the flame at 0 g (photo 8) was observed.

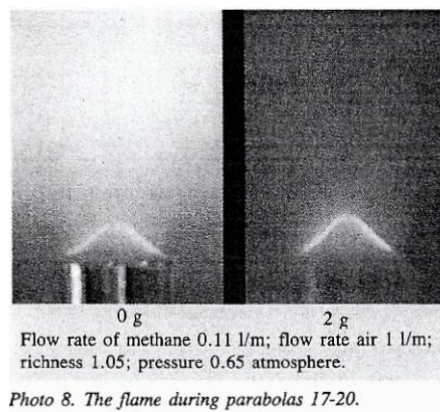

The last series (parabolas 21 to 25) deals with flames (1.6) at low pressure (0.7 atm) and with low flows to achieve short flames with no oscillation at the top. The conclusions are more difficult to draw in this configuration. It seems in fact that for two parabolas the flame, when passing from 2 g to 0 g, first shortens very slightly before growing to a much larger size than the flame at 2 g. In the other cases the flame immediately becomes much bulkier at 0 g. During the 0-gravity period the flame is rarely stable, and it swells and reduces according to the axis of the burner. As already seen in the first series, there is no doubt that there are some effects of a residual gravity which may sufficiently alter the buoyancy forces. These flames are in fact relatively rich and the diffusion and buoyancy phenomena are very important.

## CONCLUSION

These first experiments with premixed air/methane Bunsen-type flames in microgravity revealed several interesting phenomena:

- The flame pumping at the top, observed in high flames (obtained with an equivalence ratio of 1.6), is due to the buoyancy effect and instantaneously disappears as soon as the experiment is in microgravity. This phenomenon of flapping is also visible at 1 g in leaner but high enough flames,

- In the case of a stoichiometric combustion, a weak decrease of the flame area occurs between 0 g and 2 g. The flames are too thin and the velocity of the gases too fast for a buoyancy effect to operate inside the front. On the other hand, some thermal convective effects downstream the front or along the burner could explain what appears to be an increase of the burning velocity. This phenomenon will be studied in a further campaign of experiments.

- As far as rich flames are concerned, a strong swelling of the flame area has been observed, which involves a strong reduction of the burning process. This may also be true for short flames but needs to be confirmed.

The results will be processed later in order to make a comparison between the laminar flame speeds at 0 g, 1 g and 2 g. Some supplementary experiments should permit to better understand the pumping phenomenon. A theoretical model is now being developed along these lines. Other experiments in microgravity are necessary to confirm some observations and to test other conditions by varying chemical kinetics, flow rates and burner diameters.

## ACKNOWLEDGMENTS

D. Durox and P. Scoufflaire conceived the experimental study and were at the forefront in realising the multi-user combustion chamber (M.U.C.C.); they also were the researchers during the flight campaign. The study was carried out under the scientific responsibility of R. Prud'homme.

We thank the ESA and ESTEC staff for their support and their help, the Houston Nasa Center which provided the airplane, the 'Laboratoire des Prototypes' of CNRS which calculated and designed the M.U.C.C. and the General Services of CNRS (boiler trade, printing press and photography) for their assistance.

## REFERENCES

[1] J Combourieu, .1. - La propagation des déflagrations dans les mélanges combustibles gazeux aux pressions égales ou inférieures à la pression atmosphérique, Thesis, Paris, June 1960.

[2] Hamins, A., Heitor, M. and Libby, P.A. Gravitational effects on the structure and propagation of premixed flames, 37th Congress of the International Astronautical Federation, Innsbruck, Austria, October 4-11, 1986.

[3] Ronney, P.D. and Watchman, H.Y. Effect of gravity on laminar premixed gas combustion. I-Flammability limits and burning velocities, *Combustion and Flame*, **62**, 2, 1985.

[4] Ronney, P.D. Effect of gravity on laminar premixed gas combustion, II-Ignition and extinction phenomena, *Combustion and Flame*, **62**, 2, 1985.

[5] Pelce, P. and Clavin, P. Influence of hydrodynamics and diffusion upon the stability limits of laminar premixed flames, *Journal of Fluid Mech.*, **124**, 219-237, 1982.



[6] Pelce, P. Effect of gravity on the propagation of flames in tubes, *J. Physique*, **46**, 503-510, 1985.

Parabola N°	Flow rate velocity m/s	equivalence ratio	pressure
1	0.77	1.57	1
2	0.58	1.59	1
3	0.48	1.60	1
5	0.77	1.16	1
6	0.82	1.05	0.9
7	0.62	1.08	0.9
8	0.51	1.07	0.9
9	0.43	1.13	0.9
10	0.73	1.20	0.9
11	0.82	1.05	0.9
12	0.74	1.05	1
13	0.92	1.05	0.8
14	1.05	1.05	0.7
15	0.79	1.08	0.7
16	0.85	1.08	0.65
17	0.79	1.08	0.65
18	0.71	1.07	0.65
19	0.57	1.05	0.65
20	1.08	1.02	0.7
21	0.69	1.60	0.7
22	0.55	1.62	0.7
23	0.39	1.66	0.7
24	0.41	1.57	0.7
25	0.36	1.51	0.7

*Results of experiments carried out during the 25 parabolas flown during April 21st, 1987 flight.*