



HAL
open science

Autonomous, Short range Communication device

Ammar Ahmed, Jean-François Diouris, Jean-Yves Baudais

► **To cite this version:**

Ammar Ahmed, Jean-François Diouris, Jean-Yves Baudais. Autonomous, Short range Communication device. Fifth Sino-French Workshop on Information and Communication Technologies (SIFWICT 2019), Jun 2019, Nantes, France. hal-02167082

HAL Id: hal-02167082

<https://hal.science/hal-02167082v1>

Submitted on 28 Jun 2019

HAL is a multi-disciplinary open access archive for the deposit and dissemination of scientific research documents, whether they are published or not. The documents may come from teaching and research institutions in France or abroad, or from public or private research centers.

L'archive ouverte pluridisciplinaire **HAL**, est destinée au dépôt et à la diffusion de documents scientifiques de niveau recherche, publiés ou non, émanant des établissements d'enseignement et de recherche français ou étrangers, des laboratoires publics ou privés.

Autonomous, Short range Communication device

AMMAR AHMED

University of Nantes
CNRS - IETR

Nantes, France

ammarahmed24@gmail.com

J.F.DIOURIS

University of Nantes
CNRS - IETR

Nantes, France

jean-francois.diouris@univ-nantes.fr

J.Y.BAUDAIS

CNRS - IETR
Rennes, France

Jean-Yves.Baudais@insa-rennes.fr

Abstract—We consider an application where we want to determine the orientation of a battery-less device (a dice). The passive system is supplied with power and the communication is obtain through the change of the load, providing a short range autonomous communication and power transfer. Modeling of such system is crucial for the analysis of the task for the detection of the orientation with or without the need of sensor. The energy harvesting is one of the crucial step in achieving the goal of the such system and it is important to determine the impact of parameters such as distance, current and size in the system.

Index Terms—wireless power transfer, magnetic field density, coupling factor, resonance frequency.

I. INTRODUCTION

The first wireless power transfer (WPT) application development by Nikola tesla [1] opened new doors for transferring power. This technology was not explored during that time but since the past decade it has attracted a lot of attention. Since the integration of WPT in mobile phones, a lot of research is being done in the context of IOT. One of major application of WPT is wireless and non-invasive transfer of power to the pace makers permanently embedded on the patient's heart. Further applications are explored to apply such principle and enhance the ease and automation of connected objects.

This paper explores another application of wireless power transfer, which could be utilized in other applications as per need. The application is a simple dice game, in which the dice is thrown on to the table and the orientation of the dice is determined. A similar application was presented in [6] [7] which utilizes an RFID based system, and comprises an accelerometer sensor for the detection of orientation. The reading range in [6] is very small and the reader has to be brought near to the dice for each roll of the dice. The approach presented in this paper utilities magnetic coupling between two coils for power transfer as well as the detection of the orientation. The dice is a passive object and does not contain any on board power source. The power is supplied through the magnetic coupling. The transmitter coil transmits the energy, which is embedded in the board of the dice game, to the receiver coil in the dice. The orientation is determined by utilizing the load on the side of the orientation. For the correct determination of the orientation of the dice the amount of energy received should be determined.

The next section explores the model of the system under consideration. Then the model is validated by the practical implementation and a comparison is made.

II. MODEL OF THE APPLICATION

A. The Two coil Wireless power transfer system

In this section the simple two coil power transfer system [3] is analyzed as shown in the Fig. 1. M_{12} is the mutual inductance which is given by the relation.

$$M_{12} = k\sqrt{L_1 L_2} \quad (1)$$

Where k is the coupling factor between two coils.

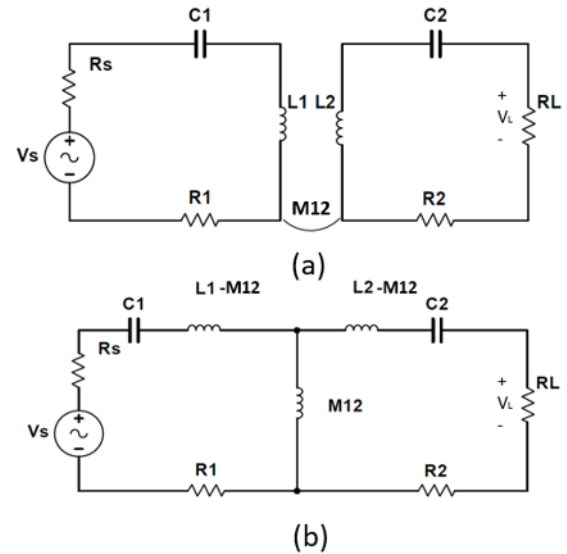

Fig. 1. (a) Two coil power transfer system (b) Equivalent T-model

I_1 and I_2 represents the current in the transmitter coil and receiver coil respectively which are defined in (5) and (6). V_S is the source voltage and V_L is the load voltage across the load R_L , the ratio is given in (4). Z_1 (2) and Z_2 (3) are the cumulative impedances at Tx and Rx coils.

$$Z_1 = R_S + R_1 + j\omega L_1 + \frac{1}{j\omega C_1} \quad (2)$$

$$Z_2 = R_L + R_2 + j\omega L_2 + \frac{1}{j\omega C_2} \quad (3)$$

$$\frac{V_L}{V_S} = \frac{j\omega M_{12} R_L}{Z_1 Z_2 + (\omega M_{12})^2} \quad (4)$$

$$I_1 = \frac{Z_2 V_s}{Z_1 Z_2 + (\omega M_{12})^2} \quad (5)$$

$$I_2 = \frac{j\omega M_{12} V_s}{Z_1 Z_2 + (\omega M_{12})^2} \quad (6)$$

Here, ω is the pulsation of the circuit.

B. Magnetic field density

To have a comprehensive analysis of the power harvesting, the first step is to determine the magnetic field density generated from the transmitter coil at different point. Since, the amount of magnetic field density will determine the amount of power received at the receiver coil. The model presented by [2] is utilized in this study which is also the basis of [5]. It follows the basic equations of Weber and then the geometry of the coil is taking into account to determine the magnetic field density.

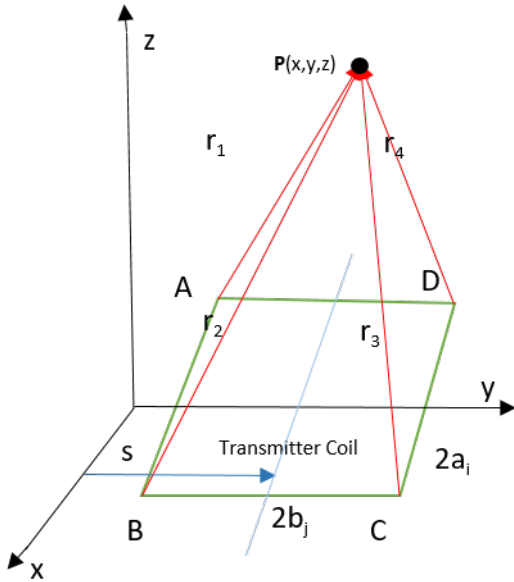

Fig. 2. Magnetic field density at point P

$$B_x = -\frac{\partial A_x}{\partial z}, B_y = -\frac{\partial A_y}{\partial z}, B_z = \frac{\partial A_y}{\partial x} - \frac{\partial A_x}{\partial y} \quad (7)$$

$$A_x = \frac{\mu_0 I_1}{4\pi} \ln \left[\frac{(r_1 + a + x)(r_3 - a + x)}{(r_2 - a + x)(r_4 + a + x)} \right] \quad (8)$$

$$A_y = \frac{\mu_0 I_1}{4\pi} \ln \left[\frac{(r_2 + b + y - s)(r_3 - b + y - s)}{(r_3 - b + y - s)(r_4 + b + y - s)} \right] \quad (9)$$

After putting (8) and (9) in (7) and taking derivatives we obtain the formula for the magnetic field density and a more computer program oriented formula :

$$B_z = \frac{\mu_0 I_1}{4\pi} \sum_{\alpha=1}^4 \left[\frac{(-1)^\alpha d_\alpha}{r_\alpha [r_\alpha + (-1)^{\alpha+1} C_\alpha]} - \frac{C_\alpha}{r_\alpha (r_\alpha + d_\alpha)} \right] \quad (10)$$

$$B_x = \frac{\mu_0 I_1}{4\pi} \sum_{\alpha=1}^4 \left[\frac{(-1)^{\alpha+1} z}{r_\alpha (r_\alpha + d_\alpha)} \right] \quad (11)$$

$$B_y = \frac{\mu_0 I_1}{4\pi} \sum_{\alpha=1}^4 \left[\frac{(-1)^{\alpha+1} z}{r_\alpha [r_\alpha + (-1)^{\alpha+1} C_\alpha]} \right] \quad (12)$$

B_x, B_y and B_z are the magnetic field density at a point due coming from each direction. For multiple turn coil, the (10), (11) and (12) are multiplied by number of turns. Also, here r_1, r_2, r_3 and r_4 are the distances to the point P(x,y,z) from each corner as shown in the Fig. 2 and are defined as :

$$r_1 = \sqrt{(a+x)^2 + (y+b-s)^2 + z^2}$$

$$r_2 = \sqrt{(a-x)^2 + (y+b-s)^2 + z^2}$$

$$r_3 = \sqrt{(a-x)^2 + (y-b-s)^2 + z^2}$$

$$r_4 = \sqrt{(a+x)^2 + (y-b-s)^2 + z^2}$$

and,

$$C_1 = -C_4 = a + x, C_2 = -C_3 = a - x$$

$$d_1 = d_2 = y + b - s, d_3 = d_4 = y - b - s$$

Where s represents the displacement from the center on the Y-axis. The total magnetic field density in each direction (13) and the magnitude is given by (14)

$$\mathbf{B} = B_x \mathbf{i} + B_y \mathbf{j} + B_z \mathbf{k} \quad (13)$$

$$\|\mathbf{B}\| = \sqrt{B_x^2 + B_y^2 + B_z^2} \quad (14)$$

For this particular application we simulated the behavior of the magnetic field density generated by the transmitter coil which is shown in Fig. 3 and Fig. 4. This relation is further used to estimate the induced voltage in the further section.

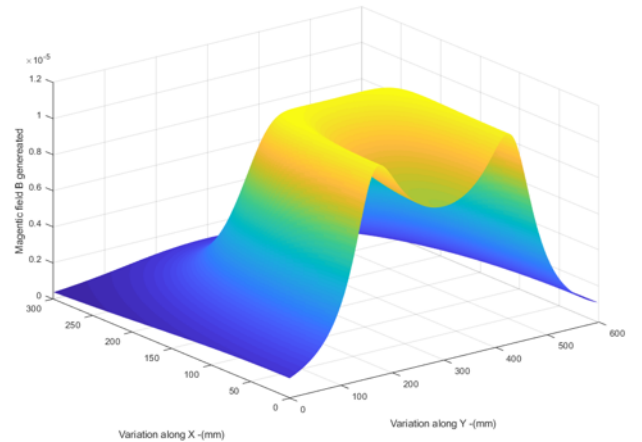

Fig. 3. Magnetic field density generated by rectangular coil.

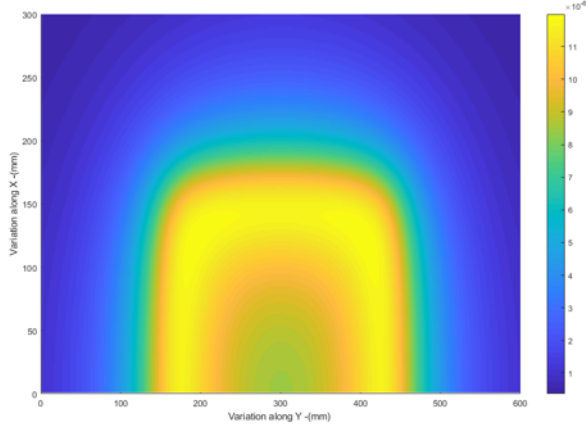

Fig. 4. Magnetic field density generated by rectangular coil (Top view).

C. Determining Mutual Inductance

Mutual inductance (1) of rectangular coil is different from circular coil. To determine the coupling factor, an analytic model [4] is considered and coupling factor of a single coil is calculated as shown in the Fig. 5 and then number of turns of transmitter and receiver coils are integrated to calculate the total mutual inductance, which is as follows. The magnetic flux is determined for each side of the coil using Biot-Savart law.

$$\phi_{ij} = \int_{S_j} \mathbf{B}_i \cdot d\mathbf{S}_j = \int_{S_j} B_{iz} \cdot dS_j = \int_{S_j} B \cdot \cos\theta \cdot dS_j \quad (15)$$

We can solve this equation by taking one side each at a time and then sum all the results to get the desired mutual inductance. The B_{CD-z} calculation is given as:

$$\phi_{CD-z} = \int_{-d_j}^{d_j} dy \int_{-c_j}^{c_j} B_{CD-z} dx \quad (16)$$

$$\begin{aligned} \phi_{CD-z} = & \frac{\mu_0}{2\pi i} \left[\sqrt{(b_i + d_j)^2 + z^2 + (a_i + c_j)^2} \right. \\ & - (a_i + c_j) \cdot \operatorname{arctanh} \frac{a_i + c_j}{\sqrt{(b_i + d_j)^2 + z^2 + (a_i + c_j)^2}} \\ & - \sqrt{(b_i + d_j)^2 + z^2 + (a_i - c_j)^2} \\ & + (a_i - c_j) \cdot \operatorname{arctanh} \frac{(a_i - c_j)}{\sqrt{(b_i + d_j)^2 + z^2 + (a_i - c_j)^2}} \\ & - \sqrt{(b_i - d_j)^2 + z^2 + (a_i + c_j)^2} \\ & + (a_i + c_j) \cdot \operatorname{arctanh} \frac{a_i + c_j}{\sqrt{(b_i - d_j)^2 + z^2 + (a_i + c_j)^2}} \\ & \left. + \sqrt{(b_i - d_j)^2 + z^2 + (a_i - c_j)^2} \right. \\ & \left. - (a_i - c_j) \cdot \operatorname{arctanh} \frac{a_i - c_j}{\sqrt{(b_i - d_j)^2 + z^2 + (a_i - c_j)^2}} \right] \quad (17) \end{aligned}$$

Here we have the flux produced by one side and the contribution of the remaining sides can be calculated as shown in Fig. 5. To calculate the remaining three sides the similar methodology can be applied and then by replacing a_i with b_i , and c_j with d_j in equation to get ϕ_{BC-z} .

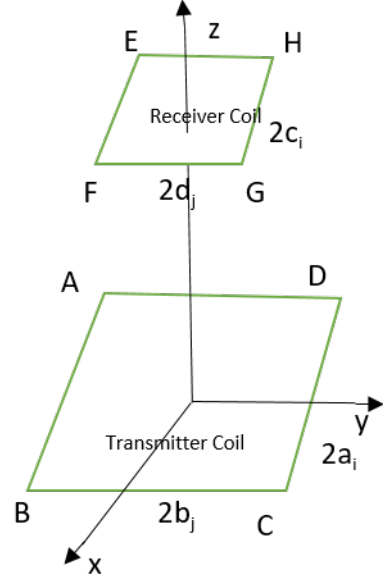

Fig. 5. Rectangular Tx and Rx coils.

Also, we have $\phi_{AB-z} = \phi_{CD-z}$ and $\phi_{DA-z} = \phi_{BC-z}$. The overall magnetic flux is given by.

$$\phi_{ij} = \phi_{AB-z} + \phi_{CD-z} + \phi_{DA-z} + \phi_{BC-z}$$

Hence, the mutual inductance is given by $M_{ij} = \phi_{ij}$. For the multiple number of turns of transmitter N_T and receiver coil N_R , the total mutual inductance is given as

$$M = \sum_{i=1}^{N_T} \sum_{j=1}^{N_R} M_{ij} \quad (18)$$

III. EXPERIMENTAL RESULTS

To calculate the voltage induced in the receiver coil, across the load resistance we need to take into account other parameters such as quality factor (Q), Resonance frequency (f_0) and the area of the receiver coil (S).

$$f_0 = \frac{1}{2\pi\sqrt{LC}} \quad (19)$$

$$Q = \frac{1}{R} \sqrt{\frac{L}{C}} \quad (20)$$

The output voltage is defined as :

$$V_0 = 2\pi f_0 Q S B_0 \cos\alpha \quad (21)$$

The voltage induced is directly proportional to the angle of the arriving signal and the angle of the receiver antenna

coil. The maximum voltage is induced when the coil is perpendicular to the arriving magnetic field where $\alpha=0$. The Fig. 6 and Fig. 7 represents the amount of voltage induced from center of the coil to the both ends of the coil in the horizontal axis and the upper half of the vertical axis, keeping the distance between the the coils constant. The similarity between magnetic field density and induced voltages could be seen, as they have quite similar curves.

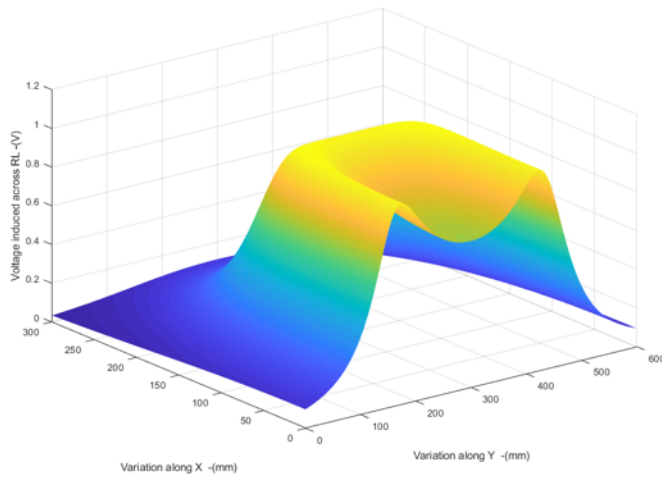

Fig. 6. Voltages induced in the receiver coil.

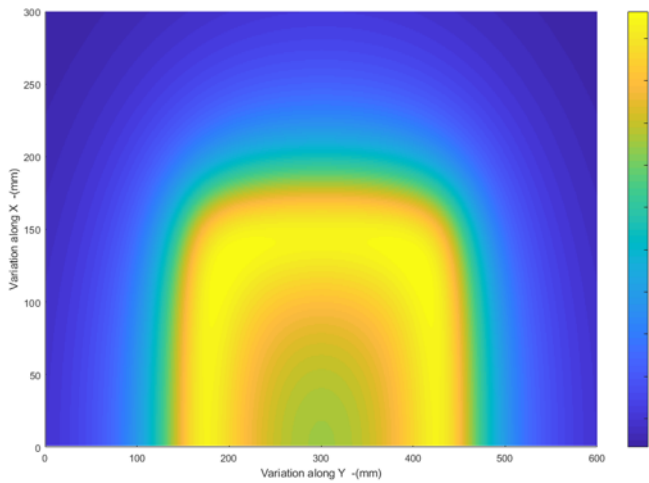

Fig. 7. Voltages induced in the receiver coil (Top view).

The experimental setup in Fig. 8 was used to validate the results. The results obtained are shown in the Fig. 9. The measured values were taken at receiver coil at the height of 4.5 cm from the surface of the transmitter coil. The two curves are not matched exactly in the Fig. 9, the relative error is accounted to be around 20 percent, which could be reduced while operating at a lower height and optimizing certain parameters in Table I. The experimental results are

TABLE I
PARAMETERS USED IN THE EXPERIMENTAL SETUP.

Parameter	Values	Parameters	Values
R_s	50Ω	R_L	120Ω
L_1	3.2 mH	L_2	$290 \mu\text{H}$
C_1	0.52 nF	C_2	5.868 nF
R_1	120Ω	R_2	50Ω
z	4.5 cm	f_0	122 kHz

taken by fixing the x and z -axis and the variation of the receiver coil along the y-axis.

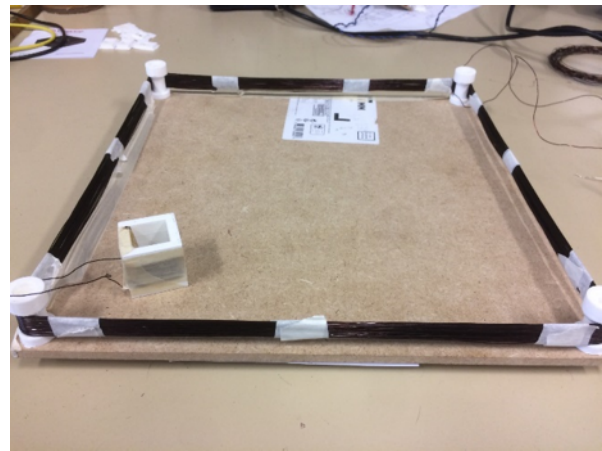

Fig. 8. Tx and Rx coil used in experiment.

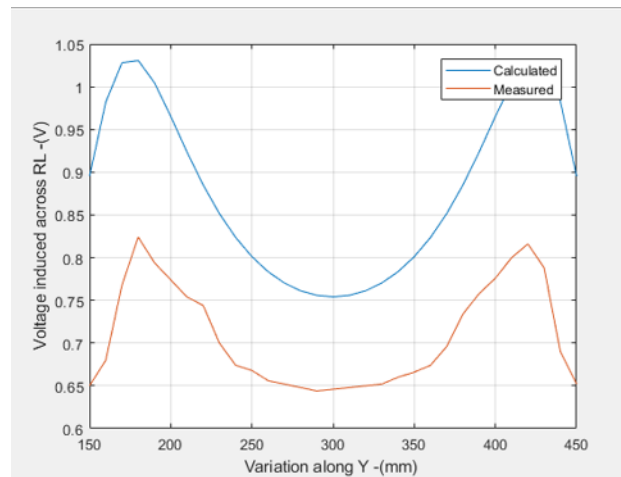

Fig. 9. Calculated and measured induced voltages.

CONCLUSION

In this preliminary work we have modeled the transmission of power between two coils, designed for a dice game application. In next work we will see the possibility to determine the dice orientation with this system. Further results will be presented during the conference.

REFERENCES

- [1] Tesla, Nikola. "Apparatus for transmitting electrical energy." U.S. Patent No. 1,119,732. 1 Dec. 1914.
- [2] Misakian, Martin. (2000). Equations for the Magnetic Field Produced by One or More Rectangular Loops of Wire in the Same Plane. *Journal of Research of the National Institute of Standards and Technology*. 105. 10.6028/jres.105.045.
- [3] Y. Cao and J. A. A. Qahouq, "Evaluation of maximum system efficiency and maximum output power in two-coil wireless power transfer system by using modeling and experimental results," 2017 IEEE Applied Power Electronics Conference and Exposition (APEC), Tampa, FL, 2017, pp. 1625-1631.
- [4] Y. Cheng and Y. Shu, "A New Analytical Calculation of the Mutual Inductance of the Coaxial Spiral Rectangular Coils," in *IEEE Transactions on Magnetics*, vol. 50, no. 4, pp. 1-6, April 2014, Art no. 7026806.
- [5] Mocholí Belenguer, Ferran Salcedo, Antonio Milián, Víctor Arroyo-Nunez, Jose. (2018). Double Magnetic Loop and Methods for Calculating Its Inductance. *Journal of Advanced Transportation*. 2018. 1-15.
- [6] S. Sasaki, T. Seki and S. Sugiyama, "Batteryless Accelerometer Using Power Feeding System of RFID," 2006 SICE-ICASE International Joint Conference, Busan, 2006, pp. 3567-3570.
- [7] S. Sasaki et al., "Batteryless-Wireless MEMS Sensor System with a 3D Loop Antenna," *SENSORS*, 2007 IEEE, Atlanta, GA, 2007, pp. 252-255.