



HAL
open science

Beyond Unpredictability: The Importance of Reproducibility in Understanding the Protein Corona of Nanoparticles

Sandra Galmarini, Usawadee Hanusch, Manon Giraud, Noelie Cayla, Diego Chiappe, Nadia von Moos, Heinrich Hofmann, Lionel Maurizi

► **To cite this version:**

Sandra Galmarini, Usawadee Hanusch, Manon Giraud, Noelie Cayla, Diego Chiappe, et al.. Beyond Unpredictability: The Importance of Reproducibility in Understanding the Protein Corona of Nanoparticles. *Bioconjugate Chemistry*, 2018, 29 (10), pp.3385-3393. 10.1021/acs.bioconjchem.8b00554 . hal-02163525

HAL Id: hal-02163525

<https://hal.science/hal-02163525>

Submitted on 8 Mar 2021

HAL is a multi-disciplinary open access archive for the deposit and dissemination of scientific research documents, whether they are published or not. The documents may come from teaching and research institutions in France or abroad, or from public or private research centers.

L'archive ouverte pluridisciplinaire **HAL**, est destinée au dépôt et à la diffusion de documents scientifiques de niveau recherche, publiés ou non, émanant des établissements d'enseignement et de recherche français ou étrangers, des laboratoires publics ou privés.

Beyond unpredictability: the importance of reproducibility in understanding the protein corona of nanoparticles

Sandra Galmarini¹, Usawadee Hanusch², Manon Giraud², Noëlie Cayla², Diego Chiappe³, Nadia von Moos², Heinrich Hofmann² and Lionel Maurizi^{2,4}*

1: Building Energy Materials and Components, Eidgenössische Materialprüfungs- und Forschungsanstalt (EMPA), CH-8600 Dübendorf, Switzerland

2: Laboratory of Powder Technology, Ecole Polytechnique Fédérale de Lausanne, CH-1015 Lausanne, Switzerland

3: Proteomics Core Facility, Ecole Polytechnique Fédérale de Lausanne, CH-1015 Lausanne, Switzerland

4 : Laboratoire Interdisciplinaire Carnot de Bourgogne, UMR 6303, CNRS, Université Bourgogne Franche-Comté, BP 47870, F-21078 Dijon Cedex, France

Abstract

While it is well established that the surface of a nanoparticle plays a pivotal role for the protein corona, the vast number of proteins present in biological media render general conclusions about affinities between nanoparticle surfaces and proteins non-trivial. Recently published articles

increasingly reveal differences between systems and an ever increasing number of influencing factors for the protein corona. In contrast, the present study posits that the reported differences may, at least in part, be due to poor experimental design, which leads to biased results.

The present study investigates protein adsorption onto silica nanoparticles with different chemical groups on the surface by the statistical analysis of triplicate measurements as well as control measurements. We demonstrate that 60 % of the identified protein types did not have any significant affinities for the nanoparticles. Of the remaining 40%, 60% were driven by surface charges and only 40% preferentially adsorbed onto specific surface groups. Furthermore, we found that of the 20 most abundant proteins in the serum, only five bound to the nanoparticles studied here. We illustrate the importance of control replicate experiments to avoid exaggerated differences between systems and to properly quantify the differences and similarities between comparable systems.

Introduction

The development of nanoparticles (NPs) for biomedical purposes has seen an exponential growth over the last two decades¹⁻⁴. The novel and customizable specific physico-chemical properties brought about by their nanometric size enable innovations in numerous medical and biological fields such as diagnosis, specific targeting and therapy. However, even though their tiny sizes and promising properties bear the potential for huge changes to the future of medicine, many questions with regard to their behavior within living systems remain to be answered. Most recently, it has become clear that describing preferential biological affinities of nanoparticles solely by the properties of their surface coatings is too simplistic an approach in the light of newest findings showing that surfaces interacting with living systems will be screened by a corona of adsorbed proteins^{5,6}. The view that nanoparticles, once in contact with biological

fluids, will interact with proteins and form a protein corona⁷⁻¹¹, which directly influences their biological behavior is now widely accepted^{9,12-15}. Nevertheless, understanding the interactions between nanoparticles and proteins remains a challenge and the investigation of influencing parameters of the protein corona¹⁶ has gained increasing attention within the scientific community. Based on current literature, the main factors influencing the protein corona include surface charges^{17,18}, surface polarity¹⁹⁻²¹ as well as particle size^{22,23}. Moreover, the chemical nature of the coatings themselves has also been shown to have an important influence^{19,24,25}. Other recent studies focused on the influence of the environment on protein adsorption, such as physiological differences in biological fluids^{26,27}. However, apart from very few exceptions^{21,28}, most studies generally conclude that coronas are different, without going into any details or further analyses of the results. This is, amongst other things, likely due to the vast number of proteins present in biological media which renders general conclusions about affinities between nanoparticle surfaces and proteins non-trivial. In fact given the huge size of the property space for nanoparticles in biological environments, a way forward might be data driven artificial intelligence methods, such as machine learning algorithms, generating models with good predictivity and some degree of interpretability²⁹. However, this approach, while probably the fastest way to develop initial data that regulatory bodies may find useful, is dependent on high quality data (protein corona composition) and needs complementary methods for validation and true understanding. In this context there is a growing body of literature emphasizing the importance of the precise measurement of conditions and the transient nature of the protein corona itself^{11,30-33}. Yet, few studies focus on experimental reproducibility and completely neglect the importance of control measurements required for proper analyses^{34,35}, which is

crucial for the correct interpretation of results. To our knowledge, this is the first study to include both triplicates as well as control measurements, which is unprecedented so far.

Silica nanoparticles have been extensively researched. Literature suggests that the main parameters that affect the protein corona in a given medium under given conditions include surface charges¹⁹, particle size^{22,23} the chemical nature of the coatings themselves and the types of chemical groups present at the surface. There is also evidence that the surface group affects the composition of the protein corona on silica nanoparticles¹⁹. However, the particles which were investigated in this specific study differed in various aspects (i.e. hydrodynamic diameter, zeta potential), which complicates final conclusions. To our knowledge, the only study in which NPs with identical charge and size and different surface groups have been investigated, has been authored by Lundqvist *et al.* for two types of polystyrene particles²¹.

In the present study, the effects of small changes in surface chemistry on the interactions between proteins and nanoparticle were scrutinized. Concurrently, the importance of reproducibility as well as of control experiments was also investigated. To this end, magnetic silica bead nanoparticles were selected with three types of strongly hydrophilic chemical surface groups representing the most abundant chemical groups providing negative charges: hydroxyl (OH), carboxyl (COOH) and a mixture of thiols and carboxyl (COOH and SH). The size and zeta potential of the different particles under investigation were identical, i.e. within the error of measurement. The selected nanoparticles were incubated in fetal bovine serum (FBS) at pH 7.4, washed on a magnetic reactor and analyzed by liquid chromatography/mass spectroscopy to identify the proteins present, according to similar procedures found in the literature^{11,36-38}. All experiments were run in triplicates to assess the reproducibility of the method by statistical analysis. In addition, control experiments without NPs were included to test for the presence of

proteins in the absence of NPs, *e.g.* due to the specific adsorption onto the magnetic separator device during the washing steps.

We show the importance of statistical analyses to separate the noise from results when identifying the proteins present in the protein corona. Furthermore, we also quantify the impact of a small change in the surface chemistry on the composition of the protein corona and discuss the effects of charges on proteins. Finally, we demonstrate how crucial control experiments are to draw unbiased conclusions on the protein corona.

Results and discussion

The following three types of magnetically labelled silica nanoparticles (NPs) were used in the experiments: naked and functionalized with citrates or dimercaptosuccinic acid (DMSA). The resulting surface chemistries of the three particles were -OH (hydroxyl groups on naked-NPs: NPs-OH), -COOH (carboxyl groups on citrate-NPs: NPs-COOH) and a mixture of -COOH and -SH (carboxyl and thiols groups on DMSA-NPs: NPs-COOH/SH). The coatings were verified by X-Ray photoelectron spectrometry (XPS Table S1 in supporting information). The three types of NPs had the same hydrodynamic diameter (measured by Dynamic Light Scattering: DLS at pH 7.4), within the accuracy of the measurement (Figure 1). This was expected because the molecules used to coat the NPs are very small. Since the small organic molecules at the surface are not visible by transmission electron microscopy (TEM), the diameter measured by this method remains unchanged. The zeta potentials of the different NPs were also within the error of measurement (between -25 and -29 ± 3 mV, Figure 1), indicating a surface charge that is independent of the coating under physiological conditions.

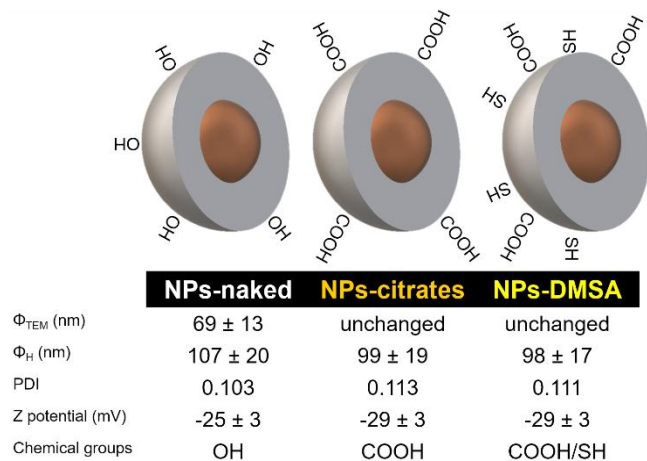

Figure 1. Nanoparticles (NPs) of functionalized silica beads with embedded iron oxide cores. These NPs are functionalized with either citrates, dimercaptosuccinic acid (DMSA) or not functionalized (naked). The diameter of the particles as measured by Transmission Electron Microscopy (Φ_{TEM}) is unchanged for all particles as the small organic groups at the surface are not visible by TEM. The hydrodynamic diameter (Φ_H) as well as the measured zeta potentials are similar for all NPs analyzed. The only difference is the chemical groups present at the surface. (PDI: polydispersity index)

Statistical analysis was used to interpret the results. Out of the 269 proteins analyzed, only 143 could be identified with sufficient probability and of those identified, only 102 unique proteins have known properties (38%) and were identified in a statistically relevant and reproducible manner within the triplicates. This highlights the importance of replicates in protein interaction experiments to remove those proteins (126 out of 269) that can only be found sporadically and not in a reproducible or statistically relevant manner. In fact, the mass spectroscopy results are quite noisy, especially for proteins present in small quantities. A lack of replicates will lead to an exaggeration of the differences between samples due to noise. However, scarcely any study accounts for this circumstance by running triplicates in the mass spectroscopy and protein identification experiments, probably due to the costly nature of these experiments. In fact, out of the last 20 publications on protein corona, only two identified proteins based on triplicates^{39,40}

(according to Web of Knowledge, accessed on 12th August 2018). Our results indicate that the omission of triplicates to account for analytical noise may lead to supposed and exaggerated differences between different systems.

While the restriction to known proteins (102 out of 143) allows a discussion of the influence of factors such as the overall charge of the proteins, it does not influence the general trends discussed below, as can be found in the comparison between the statistics of the full and reduced set of proteins presented in the supporting information (Table S2, S3 and S4).

The relative frequency of the most abundant, unique and identified proteins in the analyzed systems (>1%, corresponding to 35 types of proteins) are shown in Figure 2. It is interesting to note that 6 of these proteins (5.9 % of known, unique protein types) were also found in the control experiment without nanoparticles in the system (Figure 2). This indicates that these proteins at least partially adsorbed onto the tubing and the coil of the magnetic separator (see details in the materials and methods) used for the washing of the nanoparticles, rather than onto the NPs themselves. In fact, for four of these proteins (Apolipoprotein A-I excluded), the relative quantities found in the presence of nanoparticles were less than without NPs. Due to the semi-quantitative nature of the applied analysis, in which only relative and not absolute quantities of proteins are measured, one could argue that the total quantity of the proteins in the control experiment might have been less and thus the observations for the NPs may still be valid. However, the fact that among these serum albumin was the most frequent protein, and that the ratio between the proteins remained roughly the same for all experiments (Alpha-1-antitrypsin/serum albumin = 16-17%, KRT6A protein/serum albumin = 11-15%, Transthyretin/serum albumin = 2-4 %) indicates that the quantities of at least four of the proteins mainly stemmed from interactions with the device used during the washing step. It is also

interesting to see that two of these proteins are part of the most abundant proteins in the serum. As a matter of fact, the number of elution steps was carefully optimized so as to wash out the excess proteins, without also removing the proteins of the protein corona (see materials and methods and supporting information). However, if proteins adsorb equally strongly onto the separating device used during the elution step, they will also be found in the nanoparticle suspensions recuperated at the end of the washing for further experiments. Also, the washing was optimized to remove as little as possible of the hard protein corona while at the same time removing as many of the surrounding proteins as possible. However, a complete separation is not realistic and thus there still might have been some few surrounding proteins even at the optimal washing point. Thus, control experiments are extremely important to identify the proteins that are not part of the NP protein corona but form a “fake corona”. In spite of this fact, none of the last 20 publications on protein coronas report any control experiments and no other published work is known to the authors which includes control experiments (according to Web of Knowledge, accessed on 12th August 2018).

Thus, our results show that control experiments and reproducibility are crucial for unbiased and reliable results on the protein corona. Based on our findings, the nanoparticles studied here clearly interact with 96 out of the 102 unique and known identified proteins, since they were only detected in statistically relevant quantities in the presence of NPs.

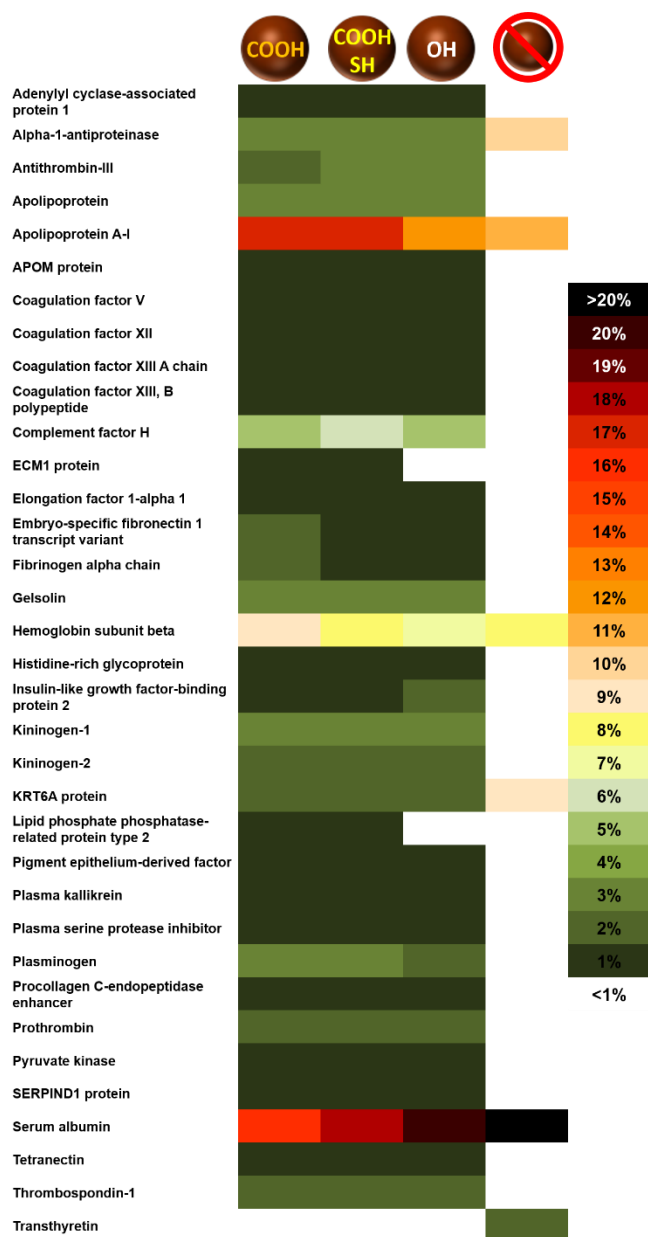

Figure 2. Level of abundance of the proteins in the protein corona of NPs-COOH, NP-COOH/SH, NPs-OH and the device only determined by proteomic analyses. The most abundant proteins present in the analyzed systems (more than 1%) are represented. Most of these are found on all the nanoparticles, whatever their surface functionalization.

To further understand the protein-NP interactions, the 96 remaining types of proteins were divided into 4 different groups (see materials and methods and supporting information Table S2 for more details):

- 1) proteins found on all the nanoparticles in equal quantities whatever their functionalization (non-specific interactions);
- 2) proteins only found in the presence of -COOH and/or -SH groups;
- 3) proteins found in larger quantities in the presence of -COOH and/or -SH groups;
- 4) proteins found in larger quantities on naked NPs, indicating a larger affinity for -OH groups.

The results are detailed in Figure 3-a and -b.

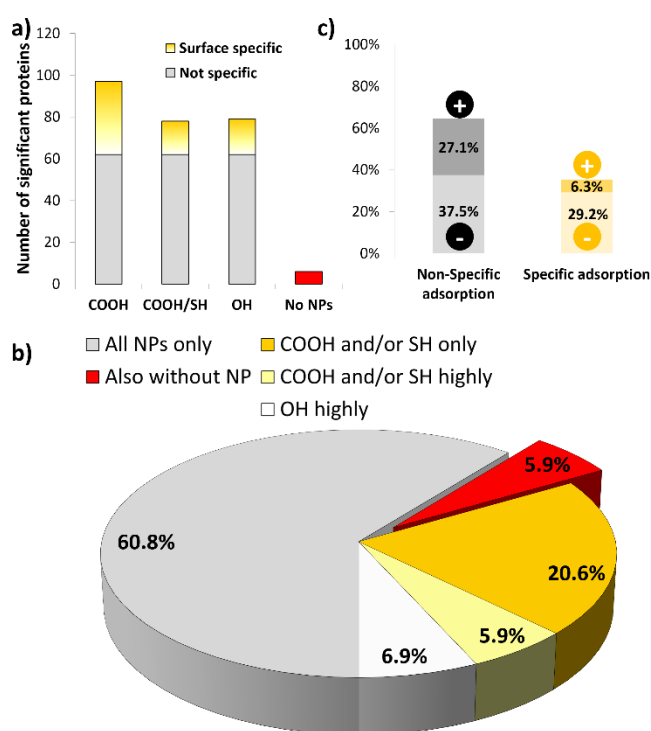

Figure 3. Reproducible protein corona analyses on the surface of functionalized nanoparticles. a) Number of proteins found per type of NP and in the control experiments; b) Pie chart showing the proportion of proteins in the control experiments, on all nanoparticles or with the different chemical groups of the coatings according to the statistical analysis; c) repartition of the charges of proteins found significantly on the nanoparticles with and without surface group specificity.

The first group with 62 proteins (61%) is the largest and is composed of proteins found in equal amounts on all particles whatever the surface functionalization. All of the most abundant

proteins not found in the control experiment (see Figure 2) belong to this category. This indicates that a large part but not the entire protein corona is indeed controlled by general NP properties such as charge, hydrophilicity and size. Indeed, this percentage is higher compared to that reported by Lundqvist *et al.*²¹, even though we did not only look for the presence of a protein but also compared differences in relative frequencies. However, in that particular study, the particle size and zeta potential varied more than for the particles studied here. In addition, even though the measurements for the general pattern, and band intensities on the 1D gels were repeated at least twice, the identification of the proteins by mass spectroscopy was only performed once, which, as shown above, is likely to exaggerate differences between particle types to some extent. For the remaining 34 protein types, specific interactions with the different surface groups were observed: 21 of the proteins were significantly present only with either citrate and/or DMSA functionalization. The amount of these proteins in the corona was always higher in the presence of citrates compared to DMSA. 18 of the protein types in this group were even only found in significant amounts in the presence of citrates. A further 6 proteins, although also present in systems with naked NPs, were found in significantly higher amounts in the presence of citrates and DMSA coated particles, again with higher interactions in the presence of citrates than of DMSA. This finding suggests that these proteins possess specific affinities for the –COOH groups at the surface.

For the last group comprising 7 proteins, higher amounts were found in the presence of naked compared to coated particles (both citrates and DMSA). Thus, it can be assumed that these proteins have a high affinity for the –OH groups at the surface.

Based on these observed specific interactions, we can conclude that the carboxylic acid coating increases the number of protein types interacting with the surface (Figure 3-a). Surprisingly, no

proteins were found to have higher affinity for DMSA than for citrates. Since DMSA and citrates both have -COOH groups (2 and 3, respectively), we conclude that the -SH groups did not show any positive effects on the adsorption of these proteins and may have even had a negative effect since 18 proteins adsorbed only onto COOH-NPs but not onto COOH/SH-NPs. However, it may have well been possible that that the -SH groups of this type of DMSA coated NPs were not available at the surface for specific binding to proteins. Also, since all proteins which were found to interact more strongly with the surface of naked NPs were also found in the presence of coatings, we assume that the coatings did not completely screen the NP surface and that some -OH surface groups were still available for adsorption of proteins.

This demonstrates that the chemical groups play an important role for the adsorption of almost 40% of the protein types found in the protein coronas during this study. Even though the influence of surface chemistry has already been shown by previous studies^{17,41-43}, this is the first time, to our knowledge, its impact has been quantified for such similar particles.

To further dissect the protein corona, we looked at the charges of the proteins discussed here. Of the 96 proteins in the protein corona, 34 were globally positively (35%) and 62 were negatively charged proteins (65%). The percentage was even more extreme if we consider the 29 most abundant proteins in the corona (excluding proteins adsorbed on the device, Figure 2). Of these, only 9 (i.e. 31 %) were positively charged. Thus, even though the nanoparticles were negatively charged, the majority of the proteins in the corona also seem to have been globally negatively charged. This is probably due to the large proportion of negatively charged proteins in the serum. However, 81% of the globally positively charged proteins in the corona (or 26 out of 34) were found to bind non-specifically to all types of NPs, representing 42% of all non-specifically bound protein types found in this study. Thus, it seems that for non-specific interactions the

charge is an important factor. In contrast, the proteins showing specific affinities were mainly negatively charged (82%), suggesting a weaker influence of charge in this case and an adsorption which is not governed by coulombic forces. The repartition of charges of the proteins found is shown in Figure 3-c.

Based on our findings, the influence of surface properties and chemical groups on the diversity of proteins interacting with the nanoparticles (in terms of number) is as follows in order of importance: Charges > COOH > OH > SH.

However, even though coating groups are of less importance than the charge, coating groups are essential to predict the protein corona. What is more, many factors are still unclear and further research is clearly needed.

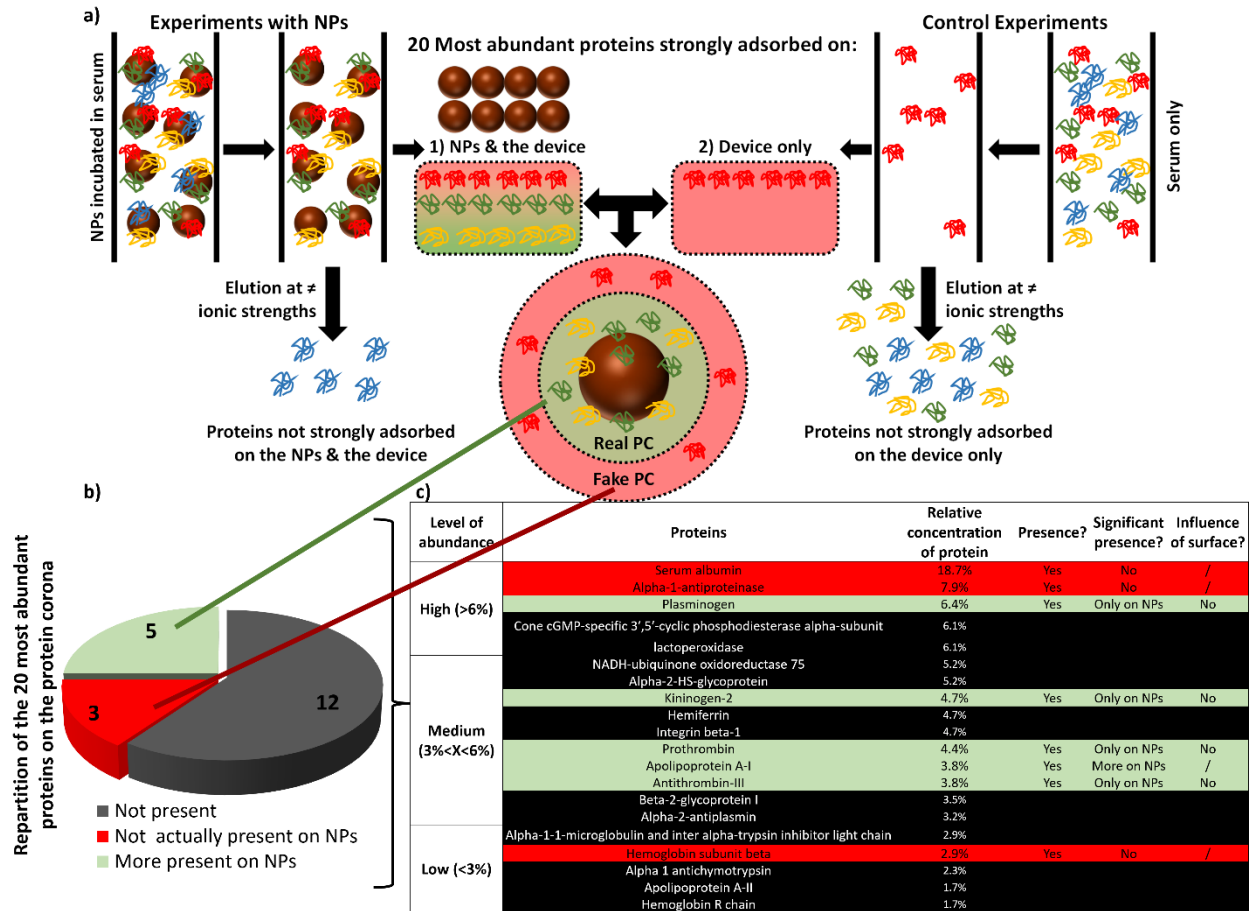

Figure 4. Results for the 20 most abundant proteins in FBS demonstrating the importance of control experiments for protein corona (PC) analyses. a) Schematic view of the method used to characterize the protein corona of different nanoparticles (NPs). NPs incubated in fetal bovine serum (FBS) were trapped in a tube inside a magnetic reactor. After the elution step, the NPs with their protein corona were removed from the reactor and the proteins contained in the system were analyzed. The same procedure was performed with only FBS and in the absence of NPs as a control experiment. b) Distribution of the 20 most abundant serum proteins: 1) found in the protein corona of the NPs (light green), 2) found more frequently in control experiments than in the presence of NPs (red) and 3) not found in a reproducible manner at all (black). Only 8 proteins were detected in a reproducible manner that was statistically significant and of those, 5 had preferential affinities for NPs. c) List of the 20 most abundant proteins with their relative proportions in the serum (from ^{19,44}) as well as the category under which they fall (see color code above).

Finally, it is very interesting to note that out of the 6 proteins identified in the control experiment, 4 belong to the 20 most abundant proteins present in FBS based on previous

studies^{19,44} (Figure 4). The 20 most abundant proteins found in FBS, constituting close to 97% (in mass)⁴⁴ of the proteins present in the serum can be divided into three groups based on their abundance, namely highly abundant (> 6%), moderately abundant (3 to 6%) and least abundant (< 3%). Out of these 20 proteins, only 8 were systematically present in a statistically significant manner (Figure 4-b and c). As mentioned above, half of these 8 proteins were also present in the control experiments without NPs. Indeed, except for the apolipoprotein A-I, the other 3 of the 4 proteins observed in the control experiments (including the 2 most abundant proteins Albumin and Alpha-1-antitrypsin) were equally abundant both in the presence and absence of NPs, indicating that they do not interact with the NPs. Lastly, the 5 proteins which were found in the protein coronas, including apolipoprotein A-I, did not show any specificity to the surface coatings of the NPs but were all amongst the most abundant in the protein corona (Figure 2). Based on these findings, it seems that preferential affinities of these proteins to chemical groups on nanoparticle surfaces can be excluded. However, while the abundance of the proteins in the serum did not govern the types of proteins detected in the corona, it was clearly and not surprisingly a main factor in the relative frequency of adsorbed proteins. This means that the composition of the serum will have an important effect on the composition of the corona. Therefore, the composition of the corona cannot be directly compared between studies using different types of serum. On the other hand, it can be supposed that the amount of specific / non-specific protein adsorption is similar for different serums, since this is a property averaged over a large number of protein types, but this remains to be validated.

Furthermore, the fact that three of the 20 most abundant proteins, including Albumin and Alpha-1-antitrypsin (representing more than 25% of the proteins from serum), were found in the control experiment stresses the importance of control replicates. As a matter of fact, Albumin

is usually always found on the surface of silica nanoparticles^{17,42,43,45-47}, whatever their functionalization. The current findings indicate that there is no albumin adsorption on the nanoparticles studied here and thus seems irrelevant for understanding the behavior of these NPs. The fact that in studies without control experiment, albumin is present in an almost systematic manner and has often been found to adsorb on similar nanoparticles as the ones studied here, underlines the need for more frequent and systematic control experiments when characterizing the protein corona. The results reported here demonstrate the primordial importance of sufficient replicates and proper control replicates for the identification and quantification of individual proteins in protein coronas. We also emphasize that the type of tubing will considerably affect the outcome. The results of the control experiment reported here are only valid for the particular experimental set-up reported herein. Thus, in order to correct for any potential bias, proper control experiments need to be run for every testing set-up under the exact same testing conditions.

Conclusion

The protein corona is key to better understand interactions between nanomaterials and proteins in biological fluids but this promising, multidisciplinary research field still faces substantial challenges. It is still often difficult to directly compare results from different studies. Moreover, recent research efforts revealed a tremendous diversity and variation of the composition of protein coronas in different systems and fueled the discovery of an ever increasing number of determining factors. This study demonstrates the utmost importance of replicate measurements and statistical analyses in separating the noise from true differences between systems. In the experimental system described here, 60% of the proteins were only detected sporadically and not in a statistically reproducible manner.

What is more, the inclusion of a sufficient number of replicates and control experiments allows the quantification of differences in composition of protein coronas in different systems. Of the protein types identified in a reproducible manner, 60% interacted in a non-specific way with all three surface-treated NP types studied here. This interaction was likely charge driven. The remaining 40% of the detected protein types showed specific interactions with small chemical groups at the nanoparticle surfaces (-COOH, -OH and -SH). It is our hope that this study helps lead the way forward towards reducing the unwieldy number of possible determining factors to a practicable number of main factors.

Finally, it is also crucial to consider the impact of the experimental set-up, as was demonstrated by the most abundant proteins (albumin included), which were more abundant in the control experiment without NPs than in their presence. Without proper control experiments, this class of highly abundant proteins could bias and confound the results and obstruct the proper understanding of the protein corona. Thus, the inclusion of control experiments is expected to significantly improve the comparability of results between different studies. Together with the reproducibility, this is of high importance for producing the large, reliable and comparable set of high quality data that is required for data driven artificial intelligence methods.

In conclusion, we believe that there is an urgent need for standardized procedures, comprising carefully and well-conceived experimental design with proper controls, which produce statistically robust and reproducible results within and between studies, to improve our understanding of the protein corona.

Materials and methods

Nanoparticle synthesis

Chemical references are given in the supporting information. Silica encapsulating iron oxide nanoparticles (SPIONs) were synthesized according to a previously described method⁴⁸. The obtained silica magnetic beads are called nanoparticles (NPs) throughout the manuscript. They contain around 8 mg of nanoparticles / mL and 0.5 mg_{Fe}/mL.

The NPs were then modified with citrates and DMSA. 10 mL of NPs were mixed with 10 mL of acidic solution at around 38 mmol L⁻¹ (73.5mg of citric acid and 70mg of DMSA in 10 mL of H₂O, respectively). The pH of the solution was verified and adjusted to above 3 with 0.1 M HCl and 0.1 M NaOH to avoid dissolution of the iron oxide nanoparticles. The nanoparticles were washed by centrifugation at 30'000 g in DI water until the pH reached the pH of DI water (around pH 5.5). Finally, the pH of the resulting NPs-naked (NPs-OH), NPs-citrate (NPs-COOH) and NPs-DMSA (NPs-COOH/SH) dispersions were adjusted to pH 7.4 with 0.1M HCl and 0.1M NaOH solutions before further use and characterization (detailed in the supporting information).

Incubation of NPs with proteins

To measure protein interactions with the three differently coated, negatively charged NPs, the NPs were put in contact with Fetal Bovine Solution (FBS). Based on previous experience from our research our group^{12,19,38}, reproducible results are achieved by incubation of NPs with the serum during 1h at a ratio of 2.8 mL FBS per m² of nanoparticles²¹ at pH 7.4. The NP volumes were adjusted to 1 mL of serum in order to keep the ratio of 2.8 mL FBS/m². Each incubation experiment was repeated three times. FBS without NPs was also used as a control for proteins found independent of the presence of NPs.

Protein corona elution

After incubation, around 1.2 mL of serum with or without NPs were loaded into a 0.5 mL FEP tube (Fluorinated ethylene propylene from Saint Gobain Performance Plastics™ ref: C200320X08010) with an Iron/Nickel coil (Fe_{52%}/Ni_{48%} from Goodfellow, ref: 198-542-54) in its center, which was then placed into a magnetic reactor previously developed^{38,49} (Figure 5). This particular FEP was selected for its low affinity to proteins⁵⁰. Three loadings of approximately 0.4/0.5 mL were performed with 15 minutes breaks in between to allow magnetic attraction to occur between the NPs, protein mixture and the magnetized coil.

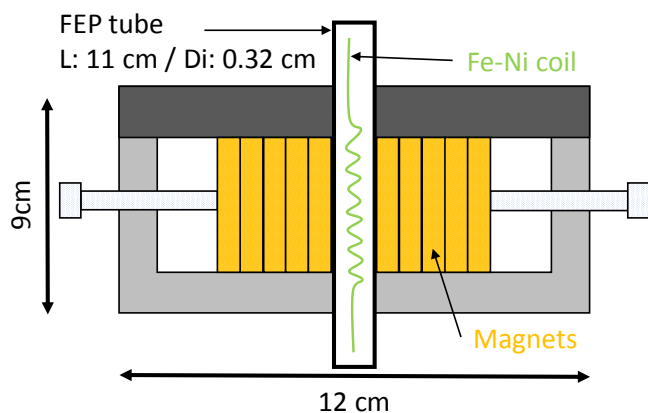

Figure 5. Magnetic device used to load magnetic nanoparticles and separate their protein corona. (FEP: Fluorinated ethylene propylene; Fe-Ni: Iron (52%) / Nickel (48%) alloy; Di: Inner Diameter)

Subsequently, the trapped NPs with serum proteins were washed at 0.5 mL/min with a peristaltic pump at 10 column volumes (10*0.5 mL) of PBS 1X (PBS 0) and 10 column volumes of PBS 1X with NaCl solution at 2M. This procedure removed excess and unbound proteins (see supporting information). After removal of the magnetic field, the NPs with the tightly bound proteins were removed from the column for further analyses. This step was repeated for every treatment (NPs-OH, NPs-COOH and NPs-COOH/SH prepared in triplicates) and for FBS only as a control (12 samples in total).

Protein corona analyses

First, the proteins from the 12 samples were separated by a one-dimension SDS-PAGE analysis (sodium dodecyl sulphate polyacrylamide gel electrophoresis). Then, LC-MS² (Liquid Chromatography Mass Spectroscopy) separations were performed on a Dionex Ultimate 3000 RSLC nano UPLC system (Thermo Fischer Scientific) on-line connected with an Orbitrap Elite Mass Spectrometer (Thermo Fischer Scientific) to quantify the different proteins present. The full procedures of SDS-page and LC-MS² are described in the supporting information.

The signal to noise ratio of the protein analysis was quite high. The results varied strongly between the three replicates. Therefore, a multiple linear regression was used to determine statistically relevant results and differences between the different particles as well as the control measurements. The limit of statistical relevance was the t-test statistic of > 0.01 . However, since a large number of parameters were analyzed independently, there is still some probability that a (small) number of the observed trends could be false positives. Therefore, we limited our discussion to different groups of proteins rather than focusing on single proteins. The full details of the statistical analyses are provided in the supporting information.

ASSOCIATED CONTENT

Supporting Information

Full experimental procedures as well as supporting data are available in the supporting information PDF file.

AUTHOR INFORMATION

Corresponding Author

*lionelmaurizi@gmail.com

Author Contributions

The manuscript was written through contributions of all authors. All authors have given approval to the final version of the manuscript.

Funding Sources

This work as supported by the Nanodiara FP7 Project of the EU Framework 7 Programme.

ACKNOWLEDGMENT

We would like to acknowledge the Nanodiara FP7 Project of the EU Framework 7 Programme, Contract no. NMP4-LA-2009-228929, and the Swiss National Science Foundation (SNSF), for their financial support.

REFERENCES

- (1) Halbreich, A.; Roger, J.; Pons, J. N.; Geldwerth, D.; Da Silva, M. F.; Roudier, M.; Bacri, J. C. Biomedical Applications of Maghemite Ferrofluid. *Biochimie* **1998**, *80* (5–6), 379–390.
- (2) Gupta, A. K.; Naregalkar, R. R.; Vaidya, V. D.; Gupta, M. Recent Advances on Surface Engineering of Magnetic Iron Oxide Nanoparticles and Their Biomedical Applications. *Nanomed.* **2007**, *2* (1), 23–39.
- (3) Vermeij, E. A.; Koenders, M. I.; Bennink, M. B.; Crowe, L. A.; Maurizi, L.; Vallée, J.-P.; Hofmann, H.; van den Berg, W. B.; van Lent, P. L.; van de Loo, F. A. The In-Vivo Use of Superparamagnetic Iron Oxide Nanoparticles to Detect Inflammation Elicits a Cytokine Response but Does Not Aggravate Experimental Arthritis. *PloS One* **2015**, *10* (5), e0126687.
- (4) Loiseau, A.; Boudon, J.; Mirjolet, C.; Créhange, G.; Millot, N. Taxane-Grafted Metal-Oxide Nanoparticles as a New Theranostic Tool against Cancer: The Promising Example of Docetaxel-Functionalized Titanate Nanotubes on Prostate Tumors. *Adv. Healthc. Mater.* **2017**, *6* (16).
- (5) Lynch, I.; Dawson, K. A. Protein-Nanoparticle Interactions. *Nano Today* **2008**, *3* (1), 40–47.
- (6) Forest, V.; Pourchez, J. Preferential Binding of Positive Nanoparticles on Cell Membranes Is Due to Electrostatic Interactions: A Too Simplistic Explanation That Does Not Take into Account the Nanoparticle Protein Corona. *Mater. Sci. Eng. C-Mater. Biol. Appl.* **2017**, *70*, 889–896.

- (7) Wolfram, J.; Yang, Y.; Shen, J.; Moten, A.; Chen, C.; Shen, H.; Ferrari, M.; Zhao, Y. The Nano-Plasma Interface: Implications of the Protein Corona. *Colloids Surf. B-Biointerfaces* **2014**, *124*, 17–24.
- (8) Paula, A. J.; Martinez, D. S. T.; Araujo Junior, R. T.; Souza Filho, A. G.; Alves, O. L. Suppression of the Hemolytic Effect of Mesoporous Silica Nanoparticles after Protein Corona Interaction: Independence of the Surface Microchemical Environment. *J. Braz. Chem. Soc.* **2012**, *23* (10), 1807–1814.
- (9) Aoyama, M.; Hata, K.; Higashisaka, K.; Nagano, K.; Yoshioka, Y.; Tsutsumi, Y. Clusterin in the Protein Corona Plays a Key Role in the Stealth Effect of Nanoparticles against Phagocytes. *Biochem. Biophys. Res. Commun.* **2016**, *480* (4), 690–695.
- (10) Lesniak, A.; Fenaroli, F.; Monopoli, M. R.; Aberg, C.; Dawson, K. A.; Salvati, A. Effects of the Presence or Absence of a Protein Corona on Silica Nanoparticle Uptake and Impact on Cells. *Acs Nano* **2012**, *6* (7), 5845–5857.
- (11) Kokkinopoulou, M.; Simon, J.; Landfester, K.; Mailänder, V.; Lieberwirth, I. Visualization of the Protein Corona: Towards a Biomolecular Understanding of Nanoparticle-Cell-Interactions. *Nanoscale* **2017**, *9* (25), 8858–8870.
- (12) Sakulkhu, U.; Maurizi, L.; Mahmoudi, M.; Motazacker, M.; Vries, M.; Gramoun, A.; Beuzelin, M.-G. O.; Vallée, J.-P.; Rezaee, F.; Hofmann, H. Ex Situ Evaluation of the Composition of Protein Corona of Intravenously Injected Superparamagnetic Nanoparticles in Rats. *Nanoscale* **2014**, *6* (19), 11439–11450.
- (13) Deng, Z. J.; Liang, M.; Monteiro, M.; Toth, I.; Minchin, R. F. Nanoparticle-Induced Unfolding of Fibrinogen Promotes Mac-1 Receptor Activation and Inflammation. *Nat. Nanotechnol.* **2011**, *6* (1), 39–44.
- (14) Zyuzin, M. V.; Yan, Y.; Hartmann, R.; Gause, K. T.; Nazarenus, M.; Cui, J.; Caruso, F.; Parak, W. J. Role of the Protein Corona Derived from Human Plasma in Cellular Interactions between Nanoporous Human Serum Albumin Particles and Endothelial Cells. *Bioconjug. Chem.* **2017**, *28* (8), 2062–2068.
- (15) de Puig, H.; Bosch, I.; Carré-Camps, M.; Hamad-Schifferli, K. Effect of the Protein Corona on Antibody–Antigen Binding in Nanoparticle Sandwich Immunoassays. *Bioconjug. Chem.* **2017**, *28* (1), 230–238.
- (16) Hadjidemetriou, M.; Kostarelos, K. Nanomedicine: Evolution of the Nanoparticle Corona. *Nat. Nanotechnol.* **2017**, *12* (4), 288–290.
- (17) Kurtz-Chalot, A.; Villiers, C.; Pourchez, J.; Boudard, D.; Martini, M.; Marche, P. N.; Cottier, M.; Forest, V. Impact of Silica Nanoparticle Surface Chemistry on Protein Corona Formation and Consequential Interactions with Biological Cells. *Mater. Sci. Eng. C* **2017**, *75*, 16–24.
- (18) Huehn, D.; Kantner, K.; Geidel, C.; Brandholt, S.; De Cock, I.; Soenen, S. J. H.; Gil, P. R.; Montenegro, J.-M.; Braeckmans, K.; Muellen, K.; et al. Polymer-Coated Nanoparticles Interacting with Proteins and Cells: Focusing on the Sign of the Net Charge. *Acs Nano* **2013**, *7* (4), 3253–3263.
- (19) Sakulkhu, U.; Mahmoudi, M.; Maurizi, L.; Coullerez, G.; Hofmann-Antenbrink, M.; Vries, M.; Motazacker, M.; Rezaee, F.; Hofmann, H. Significance of Surface Charge and Shell Material of Superparamagnetic Iron Oxide Nanoparticle (SPION) Based Core/Shell Nanoparticles on the Composition of the Protein Corona. *Biomater. Sci.* **2015**, *3* (2), 265–278.

- (20) Monopoli, M. P.; Walczyk, D.; Campbell, A.; Elia, G.; Lynch, I.; Baldelli Bombelli, F.; Dawson, K. A. Physical–Chemical Aspects of Protein Corona: Relevance to in Vitro and in Vivo Biological Impacts of Nanoparticles. *J. Am. Chem. Soc.* **2011**, *133* (8), 2525–2534.
- (21) Lundqvist, M.; Stigler, J.; Elia, G.; Lynch, I.; Cedervall, T.; Dawson, K. A. Nanoparticle Size and Surface Properties Determine the Protein Corona with Possible Implications for Biological Impacts. *PNAS* **2008**, *105* (38), 14265–14270.
- (22) Tenzer, S.; Docter, D.; Rosfa, S.; Wlodarski, A.; Kuharev, J.; Rekić, A.; Knauer, S. K.; Bantz, C.; Nawroth, T.; Bier, C.; et al. Nanoparticle Size Is a Critical Physicochemical Determinant of the Human Blood Plasma Corona: A Comprehensive Quantitative Proteomic Analysis. *ACS Nano* **2011**, *5* (9), 7155–7167.
- (23) Piella, J.; Bastús, N. G.; Puntès, V. Size-Dependent Protein–Nanoparticle Interactions in Citrate-Stabilized Gold Nanoparticles: The Emergence of the Protein Corona. *Bioconjug. Chem.* **2017**, *28* (1), 88–97.
- (24) Gunkel, G.; Huck, W. T. S. Cooperative Adsorption of Lipoprotein Phospholipids, Triglycerides, and Cholesteryl Esters Are a Key Factor in Nonspecific Adsorption from Blood Plasma to Antifouling Polymer Surfaces. *J. Am. Chem. Soc.* **2013**, *135* (18), 7047–7052.
- (25) Moyano, D. F.; Saha, K.; Prakash, G.; Yan, B.; Kong, H.; Yazdani, M.; Rotello, V. M. Fabrication of Corona-Free Nanoparticles with Tunable Hydrophobicity. *Acs Nano* **2014**, *8* (7), 6748–6755.
- (26) Maiorano, G.; Sabella, S.; Sorce, B.; Brunetti, V.; Malvindi, M. A.; Cingolani, R.; Pompa, P. P. Effects of Cell Culture Media on the Dynamic Formation of Protein-Nanoparticle Complexes and Influence on the Cellular Response. *Acs Nano* **2010**, *4* (12), 7481–7491.
- (27) Bonvin, D.; Aschauer, U.; Alexander, D. T. L.; Chiappe, D.; Moniatte, M.; Hofmann, H.; Mionić Ebersold, M. Protein Corona: Impact of Lymph Versus Blood in a Complex In Vitro Environment. *Small* **2017**, *13* (29), 1700409.
- (28) Bonvin, D.; Aschauer, U. J.; Bastiaansen, J. A. M.; Stuber, M.; Hofmann, H.; Mionić Ebersold, M. Versatility of Pyridoxal Phosphate as a Coating of Iron Oxide Nanoparticles. *Nanomaterials* **2017**, *7* (8), 202.
- (29) Bai, X.; Liu, F.; Liu, Y.; Li, C.; Wang, S.; Zhou, H.; Wang, W.; Zhu, H.; Winkler, D. A.; Yan, B. Toward a Systematic Exploration of Nano-Bio Interactions. *Toxicol. Appl. Pharmacol.* **2017**, *323*, 66–73.
- (30) Ke, P. C.; Lin, S.; Parak, W. J.; Davis, T. P.; Caruso, F. A Decade of the Protein Corona. *ACS Nano* **2017**.
- (31) Giudice, M. C. L.; Herda, L. M.; Polo, E.; Dawson, K. A. *In Situ* Characterization of Nanoparticle Biomolecular Interactions in Complex Biological Media by Flow Cytometry. *Nat. Commun.* **2016**, *7*, 13475.
- (32) Forest, V.; Pourchez, J. The Nanoparticle Protein Corona: The Myth of Average. *Nano Today* **2016**, *11* (6), 700–703.
- (33) Docter, D.; Westmeier, D.; Markiewicz, M.; Stolte, S.; Knauer, S. K.; Stauber, R. H. The Nanoparticle Biomolecule Corona: Lessons Learned - Challenge Accepted? *Chem. Soc. Rev.* **2015**, *44* (17), 6094–6121.
- (34) Bonvin, D.; Chiappe, D.; Moniatte, M.; Hofmann, H.; Ebersold, M. M. Methods of Protein Corona Isolation for Magnetic Nanoparticles. *Analyst* **2017**.

- (35) Docter, D.; Distler, U.; Storck, W.; Kuharev, J.; Wünsch, D.; Hahlbrock, A.; Knauer, S. K.; Tenzer, S.; Stauber, R. H. Quantitative Profiling of the Protein Coronas That Form around Nanoparticles. *Nat. Protoc.* **2014**, *9* (9), 2030–2044.
- (36) Mahmoudi, M.; Lynch, I.; Ejtehadi, M. R.; Monopoli, M. P.; Bombelli, F. B.; Laurent, S. Protein–Nanoparticle Interactions: Opportunities and Challenges. *Chem. Rev.* **2011**, *111* (9), 5610–5637.
- (37) Simberg, D.; Park, J.-H.; Karmali, P. P.; Zhang, W.-M.; Merkulov, S.; McCrae, K.; Bhatia, S. N.; Sailor, M.; Ruoslahti, E. Differential Proteomics Analysis of the Surface Heterogeneity of Dextran Iron Oxide Nanoparticles and the Implications for Their in Vivo Clearance. *Biomaterials* **2009**, *30* (23–24), 3926–3933.
- (38) Sakulku, U.; Mahmoudi, M.; Maurizi, L.; Salaklang, J.; Hofmann, H. Protein Corona Composition of Superparamagnetic Iron Oxide Nanoparticles with Various Physico-Chemical Properties and Coatings. *Sci. Rep.* **2014**, *4*, 5020.
- (39) Sousa, M. de; Martins, C. H. Z.; Franqui, L. S.; Fonseca, L. C.; Delite, F. S.; Lanzoni, E. M.; Martinez, D. S. T.; Alves, O. L. Covalent Functionalization of Graphene Oxide with D-Mannose: Evaluating the Hemolytic Effect and Protein Corona Formation. *J. Mater. Chem. B* **2018**, *6* (18), 2803–2812.
- (40) Zhang, H.; Peng, J.; Li, X.; Liu, S.; Hu, Z.; Xu, G.; Wu, R. A Nano-Bio Interfacial Protein Corona on Silica Nanoparticle. *Colloids Surf. B Biointerfaces* **2018**, *167*, 220–228.
- (41) Mamaeva, V.; Sahlgren, C.; Linden, M. Mesoporous Silica Nanoparticles in Medicine—Recent Advances. *Adv. Drug Deliv. Rev.* **2013**, *65* (5), 689–702.
- (42) Ge, C.; Tian, J.; Zhao, Y.; Chen, C.; Zhou, R.; Chai, Z. Towards Understanding of Nanoparticle-Protein Corona. *Arch. Toxicol.* **2015**, *89* (4), 519–539.
- (43) Mortensen, N. P.; Hurst, G. B.; Wang, W.; Foster, C. M.; Nallathamby, P. D.; Retterer, S. T. Dynamic Development of the Protein Corona on Silica Nanoparticles: Composition and Role in Toxicity. *Nanoscale* **2013**, *5* (14), 6372–6380.
- (44) Zheng, X.; Baker, H.; Hancock, W. S.; Fawaz, F.; McCaman, M.; Pungor, E. Proteomic Analysis for the Assessment of Different Lots of Fetal Bovine Serum as a Raw Material for Cell Culture. Part IV. Application of Proteomics to the Manufacture of Biological Drugs. *Biotechnol. Prog.* **2006**, *22* (5), 1294–1300.
- (45) Izak-Nau, E.; Voetz, M.; Eiden, S.; Duschl, A.; Puentes, V. F. Altered Characteristics of Silica Nanoparticles in Bovine and Human Serum: The Importance of Nanomaterial Characterization Prior to Its Toxicological Evaluation. *Part. Fibre Toxicol.* **2013**, *10*, 56.
- (46) Docter, D.; Bantz, C.; Westmeier, D.; Galla, H. J.; Wang, Q.; Kirkpatrick, J. C.; Nielsen, P.; Maskos, M.; Stauber, R. H. The Protein Corona Protects against Size- and Dose-Dependent Toxicity of Amorphous Silica Nanoparticles. *Beilstein J. Nanotechnol.* **2014**, *5*, 1380–1392.
- (47) Clemments, A. M.; Botella, P.; Landry, C. C. Spatial Mapping of Protein Adsorption on Mesoporous Silica Nanoparticles by Stochastic Optical Reconstruction Microscopy. *J. Am. Chem. Soc.* **2017**, *139* (11), 3978–3981.
- (48) Maurizi, L.; Sakulku, U.; Crowe, L. A.; Dao, V. M.; Leclaire, N.; Vallée, J.-P.; Hofmann, H. Syntheses of Cross-Linked Polymeric Superparamagnetic Beads with Tunable Properties. *RSC Adv.* **2014**, *4* (22), 11142–11146.
- (49) Salaklang, J.; Steitz, B.; Finka, A.; Neil, C. P. O.; Moniatte, M.; Vlies, A. J. V. der; Giorgio, T. D.; Hofmann, H.; Hubbell, J. A.; Petri-Fink, A. Superparamagnetic

Nanoparticles as a Powerful Systems Biology Characterization Tool in the Physiological Context. *Angew Chem Int Ed* **2008**, *47*, 7857–7860.

- (50) van Wachem, P. B.; Vreriks, C. M.; Beugeling, T.; Feijen, J.; Bantjes, A.; Detmers, J. P.; van Aken, W. G. The Influence of Protein Adsorption on Interactions of Cultured Human Endothelial Cells with Polymers. *J. Biomed. Mater. Res.* **1987**, *21* (6), 701–718.

SYNOPSIS (TOC figure)

