



**HAL**  
open science

## Structure observer-based controller for delayed systems with two unstable poles and minimum phase zeros

Carlos Daniel Vázquez, David Novella, Basilio del Muro, Olivier Sename, Luc Dugard, Juan Francisco Márquez

► **To cite this version:**

Carlos Daniel Vázquez, David Novella, Basilio del Muro, Olivier Sename, Luc Dugard, et al.. Structure observer-based controller for delayed systems with two unstable poles and minimum phase zeros. IFAC TDS 2019 - 15th IFAC Workshop on Time Delay Systems, Sep 2019, Sinaia, Romania. 10.1016/j.ifacol.2019.12.224 . hal-02158088

**HAL Id: hal-02158088**

**<https://hal.science/hal-02158088v1>**

Submitted on 17 Jun 2019

**HAL** is a multi-disciplinary open access archive for the deposit and dissemination of scientific research documents, whether they are published or not. The documents may come from teaching and research institutions in France or abroad, or from public or private research centers.

L'archive ouverte pluridisciplinaire **HAL**, est destinée au dépôt et à la diffusion de documents scientifiques de niveau recherche, publiés ou non, émanant des établissements d'enseignement et de recherche français ou étrangers, des laboratoires publics ou privés.

# Structure observer-based controller for delayed systems with two unstable poles and minimum phase zeros.

Carlos Daniel Vázquez\* David Novella\*\* Basilio del Muro\*  
Olivier Sename\*\* Luc Dugard\*\* Juan Francisco Márquez\*

\* *Escuela Superior de Ingeniería Mecánica y Eléctrica, Unidad Culhuacan, Instituto Politécnico Nacional, Santa Ana 1000, México D.F., 04430, México (e-mail: carlos\_daniel\_vaz@hotmail.com)(e-mail: bdelmauro@yahoo.com)(e-mail: jfcomr23@yahoo.com.mx).*

\*\* *Univ. Grenoble Alpes, CNRS, Grenoble INP, GIPSA-lab, 38000 Grenoble, France (e-mail: dnovellar@gmail.com)(e-mail: olivier.sename@gipsa-lab.grenoble-inp.fr)(e-mail: luc.dugard@gipsa-lab.grenoble-inp.fr)*

---

**Abstract:** This paper analyse the problem of control and stabilization of a particular class of Linear Time Invariant (LTI) systems. The system under consideration has two unstable poles,  $n$  real stable poles,  $m$  minimum phase zeros plus time delay. An observer based controller with four tunable gains is proposed as control strategy in order to ensure stable behaviour of the closed loop system. Sufficient conditions for the existence of the proposed scheme are shown in terms of the upper limit of time delay size and the poles and zeros position. The controller parameters are tuned using hinfstruct which is a non-smooth  $H_\infty$  optimization method. The proposed control strategy it is applied to an unstable linearized model of a continuously stirred tank reactor (CSTR) in order to show the effectiveness of the proposed design scheme. Numerical results are presented.

*Keywords:* Time-delay, Observers, zeros, H-infinity, stability.

---

## 1. INTRODUCTION

One way to define time-delay in the context of control system theory is the time interval from the application of a control signal to any observable change in the process variable (Wang et al., 1999). Such a phenomenon can be found in several engineering processes, for example: material and information transmission, biological embedded systems, biochemical and chemical process (Wu et al., 2015).

There exist different systems with two unstable poles and minimum phase zeros with time-delay. In chemical industry, a common example is the CSTR (Bequetten, 2003). In the military field, the dynamical model of a ballistic missile has similar characteristics (H, 1991). Then, the problem of stabilization of this class of systems becomes an interesting topic and explicit stabilizability results for many unstable processes are not available yet.

Few works have addressed the problem of delayed unstable systems with zero dynamics. In (Kwak et al., 2000), the authors face the problem of stabilization for first and second order systems using a P controller as control strategy. An extended result can be seen in (Lee and Wang, 2010), where the authors analyse a high order system by simple controllers. It is important to highlight that the mentioned works only consider the problem when one minimum phase zero is involved in the original plant.

In real cases, in addition to stability, it is also necessary to guarantee typical design requirements such as speed of response, control bandwidth, disturbance rejection, and robustness unmodeled dynamics. To meet these requirements,  $H_\infty$  theory is a powerful technique used to design robust controllers for linear systems under uncertainties, parameter variations, and disturbances.

The objective of this paper is two-fold: First we propose sufficient conditions in order to stabilize a specific class of delayed systems with two real unstable poles,  $n$  stable poles and  $m$  minimum phase zeros ( $m < n + 2$ ), using a structured observer-based controller with four tunable gains. Then a systematic design procedure of the control gain is proposed in the  $H_\infty$  framework. Since the controller is structured, the non smooth  $H_\infty$  synthesis proposed in (Apkarian and Noll, 2006) has been considered, hinfstruct is an extension of the  $H_\infty$  central design method (Bouzaïd et al., 2015). One of the main advantages of hinfstruct method is to choose the order and the structure of the desired controller.

An illustrative example is considered to highlight the interest of this work, in particular compared with a full order  $H_\infty$  controller.

The remainder of the paper is organized as follows: In Section 2, we present the problem statement. In section 3, we present some preliminary results on stabilization of time-delay systems with zero dynamics. Section 4 provides

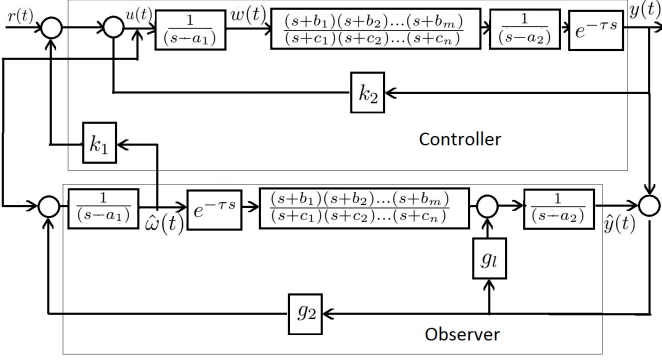

Fig. 1. Control strategy proposed.

the control strategy proposed. The standard formulation of structured  $H_\infty$  synthesis and  $H_\infty$  control design procedure are given in Section 5. An example and numerical simulation are shown in Section 6. Finally, we provide some conclusions in Section 7.

## 2. PROBLEM STATEMENT

Let us consider the class of a Single-Input Single-Output (SISO) systems with delay in the direct path, two unstable poles,  $m$  minimum phase zeros and  $n$  real stable poles given in the form:

$$G(s)e^{-\tau s} = \frac{\prod_{l=1}^m (s + b_l)}{(s - a_1)(s - a_2) \prod_{i=1}^n (s + c_i)} e^{-\tau s} \quad (1)$$

where  $a_1, a_2, m, n > 0, m < n + 2$  and  $a_1 \geq a_2$ .  $G(s)$  is the delay-free transfer function and  $\tau > 0$  is the time-delay. Also consider the observer based controller scheme show in in Fig. 1.

The objective is provide a control strategy (i.e to find parameters  $k_1, k_2, g_1$  and  $g_2$ ) in order to stabilize the closed-loop system shown in Fig. 1.

## 3. PRELIMINARY RESULTS

This section presents preliminary result used later to obtain the main results of the paper. Consider the high-order unstable system given by:

$$\frac{Y(s)}{U(s)} = H(s) = \frac{\prod_{l=1}^m (s + b_l)}{(s - a) \prod_{i=1}^n (s + c_i)} e^{-\tau s} \quad (2)$$

where  $a, m, \tau > 0$  and  $n \geq 0$ . Applying a traditional control strategy based on an output feedback of the form:

$$U(s) = C(s)[R(s) - Y(s)] \quad (3)$$

which yields to the closed-loop transfer function:

$$\frac{Y(s)}{R(s)} = \frac{C(s)H(s)}{1 + C(s)H(s)} \quad (4)$$

The following result is related to the stability of the closed-loop transfer function (4).

*Lemma 1.* Consider the delayed system (2) and the proportional output feedback shown in (3), the associated closed-loop is stable if :

$$\tau < \frac{1}{a} + \prod_{l=1}^m \frac{1}{b_l} - \prod_{i=1}^n \frac{1}{c_i} \quad (5)$$

$$\frac{\prod_{l=1}^m b_l^2}{a^2 \prod_{i=1}^n c_i^2} > \sqrt{\frac{\prod_{l=1}^m (\omega_c^2 + b_l^2)}{(\omega_c^2 + a^2) \prod_{i=1}^n (\omega_c^2 + c_i^2)}} \quad (6)$$

where  $\omega_c > 0$  is the frequency at which the phase angle is  $-\pi$ . We will demonstrate that the Nyquist plot of the controller system encircles once the critical point in counterclockwise guaranteeing the closed-loop stability according to the Nyquist stability criteria.

**Proof.** To obtain this encirclement, it is required to have two intersections with the real negative axis, one intersection should occur into  $[-\infty, -1]$  and the second one should be appear into  $[-1, 0]$ . That is:  $M_H(\omega_{c1}) > 1, \Phi_H(\omega_{c1}) = -\pi, M_H(\omega_{c2}) < 1, \Phi_H(\omega_{c2}) = -\pi$

where  $M_H(\omega)$  denote the magnitude of  $H(j\omega)$  given by:

$$M_H(\omega) = \sqrt{\frac{\prod_{l=1}^m (\omega^2 + b_l^2)}{(\omega^2 + a^2) \prod_{i=1}^n (\omega^2 + c_i^2)}} \quad (7)$$

$\omega_{c1}, \omega_{c2}$  are non-negative crossover frequencies and  $\omega_{c1} < \omega_{c2}, \Phi_H(\omega)$  denote the phase of  $H(\omega)$  given by:

$$\phi_H(\omega) = -(\pi - \tan^{-1} \frac{\omega}{a}) + \tan^{-1} \sum_{l=1}^m \frac{\omega}{b_l} - \tan^{-1} \sum_{i=1}^n \frac{\omega}{c_i} - \omega\tau \quad (8)$$

Let us assume that the conditions of Lemma 1 are satisfied. From (8) we can see that the phase trajectory begins at  $\phi_H(0) = -\pi$ , therefore  $\omega_{c1} = 0$ . This implies the first required intersection with the negative real axis. A growing of  $\phi_H(\omega)$  is required since  $\phi_H(0) = -\pi$ , this implies  $\frac{d\phi_H(\omega)}{d\omega} |_{\omega \rightarrow 0} > 0$ . If the derivative of phase is always non-positive, then only phase lag happens, and any encirclement around the critical point can only be clockwise. In this way we evaluate:  $\frac{d\phi_H(\omega)}{d\omega} |_{\omega \rightarrow 0} = \frac{1}{a} + \prod_{l=1}^m \frac{1}{b_l} - \prod_{i=1}^n \frac{1}{c_i} - \tau > 0$ . Thus, it is clear that under condition (5), there is a growing of  $\phi_H(\omega)$  since  $\phi_H(0) = -\pi$ .

Let us analyse the adequate performance of the magnitude. The value of the magnitude  $M_G(\omega)$  with  $\omega = 0$  is  $M_G(0) = \frac{\prod_{l=1}^m b_l^2}{a^2 \prod_{i=1}^n c_i^2}$ . Then, in order to archive the closed-loop stabilization, assuming condition (6) we assure that the  $M_G(\omega)$  is a decreasing function for  $\omega \approx 0$  obtaining a correct direction of the Nyquist trajectory if the conditions (5) and (6) are met. This result is an extended version of the conditions given in (Vazquez-Rosas et al., 2017).

## 4. CONTROL STRATEGY PROPOSED

To handle the problem of stabilization of time delay systems shown in Eq (1), an observer based control strategy

is proposed. The principal idea is to get an non-delayed estimation of the internal variables of the system to be used as control signals for the real process. Regardless of the order of the system, the scheme use only four tunable gains in order to obtain a stable behaviour of the closed-loop system.

*Lemma 2.* Consider the observer based controller scheme shown in Fig. 1. There exist constants  $g_1$ ,  $g_2$ ,  $k_1$  and  $k_2$  such that the closed-loop system is stable if:

$$\tau < \frac{1}{a_1} + \prod_{l=1}^m \frac{1}{b_l} - \prod_{i=1}^n \frac{1}{c_i} - \frac{1}{\beta} \quad (9)$$

and

$$\frac{\prod_{l=1}^m b_l^2}{a_1^2 \beta^2 \prod_{i=1}^n c_i^2} > \sqrt{\frac{\prod_{l=1}^m (\omega_c^2 + b_l^2)}{(\omega_c^2 + a_1^2)(\omega_c^2 + \beta^2) \prod_{i=1}^n (\omega_c^2 + c_i^2)}} \quad (10)$$

**Proof.** The details of the proof are described in (Novella-Rodrguez et al., 2014). The observer based controller proposed satisfies the separation principle (Kailath., 1980), i.e. the controller and the observer can be designed independently. The stability of the observer scheme is enough to assure an adequate error convergence, that is:

$$\lim_{t \rightarrow \infty} [\hat{\omega}(t) - \omega(t)] = 0$$

Therefore, there exist proportional gains  $g_1$ ,  $g_2$ ,  $k_1$  and  $k_2$  such that the closed-loop system is stable if the conditions of Lemma 2 are satisfied.

We can design the controller and the observer separate, such that the closed-loop systems of the complete controller-observer scheme it is stable. Using the preliminary results, we will show the stability conditions for the controller scheme, next we will show the stability conditions for the observer scheme.

Let us consider the controller scheme strategy shown in Fig. 1, we can formulate the next result:

*Lemma 3.* Consider the delayed system (1) and the control scheme shown in Fig 1. There exist constants  $k_1$  and  $k_2$  such that the close-loop system is stable if :

$$\tau < \frac{1}{a_2} + \prod_{l=1}^m \frac{1}{b_l} - \prod_{i=1}^n \frac{1}{c_i} - \frac{1}{\beta} \quad (11)$$

and

$$\frac{\prod_{l=1}^m b_l^2}{a_2^2 \beta^2 \prod_{i=1}^n c_i^2} > \sqrt{\frac{\prod_{l=1}^m (\omega_c^2 + b_l^2)}{(\omega_c^2 + a_2^2)(\omega_c^2 + \beta^2) \prod_{i=1}^n (\omega_c^2 + c_i^2)}} \quad (12)$$

where  $\beta$  being a positive real constant.

**Proof.** Consider the delayed system (1) and the state feedback controller shown in Fig. 1, with a constant gain  $k_1 > a_1$ . The closed loop transfer function of the system can be written as follows:

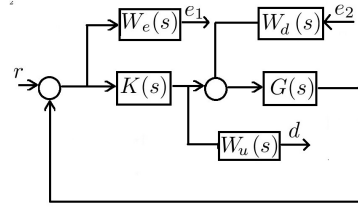

Fig. 2. Closed-loop scheme with the weighting transfer functions.

$$\frac{Y(s)}{R(s)} = \frac{\prod_{l=1}^m (s + b_l) e^{-\tau s}}{(s + \beta)(s - a_2) \prod_{i=1}^n (s + c_i) + \prod_{l=1}^m (s + b_l) e^{-\tau s}} \quad (13)$$

with  $\beta = k_1 - a_1$ , note that  $\beta$  is a free parameter function of  $k_1$ , with  $\beta > 0$  the system only has one unstable pole and  $n + 1$  stable poles. If exist  $\beta$  such that satisfies the condition (11) and (12) and taking account the Lemma 1, we can assure a stable behaviour of the closed-loop system by P controller.

Let us consider the static output injection scheme shown in Fig. 1, we can formulate the next result:

*Lemma 4.* Consider the delayed system (1) and the observer scheme shown in Fig 1. There exist constants  $g_1$  and  $g_2$  such that the close-loop system is stable if the conditions (11) and (12) are true.

**Proof.** The proof can be easily derived from a dual procedure of the previous result.

Reminding the stability conditions stated previously in Lemma 3 and Lemma 4, the observer time-delay condition is more restrictive than the controller time-delay stability conditions that is:

$$\frac{1}{a_2} + \prod_{l=1}^m \frac{1}{b_l} - \prod_{i=1}^n \frac{1}{c_i} < \frac{1}{a_1} + \prod_{l=1}^m \frac{1}{b_l} - \prod_{i=1}^n \frac{1}{c_i}$$

Thus, if the stability conditions of the observer are satisfied, automatically the conditions of the controller are satisfied to. Therefore, there exist a proportional gains  $k_1$ ,  $k_2$ ,  $g_1$ , and  $g_2$ , such that the closed-loop system is stable if the conditions shown in Lemma 2 are true.

## 5. $H_\infty$ CONTROL DESIGN PROCEDURE

### 5.1 Background on $H_\infty$ control

Mixed sensitivity optimization is a useful design tool that allows simultaneous design for performance and robustness. In Fig. 2 we can see the generalized plant for  $H_\infty$  mixed sensitivity problem where  $G(s)$  is the open loop plant,  $K(s)$  is the controller that combines all tunable control elements. Each control element of  $K(s)$  is assumed to be linear time invariant,  $W_e$ ,  $W_u$ ,  $W_d$  are weights for specify the system performance,  $d$  is the disturbance input,  $u$  is the control input,  $y$  is the measured output,  $e_1$  and  $e_2$  are regulated outputs and  $r$  is the reference input. The transfer matrix from  $r$  and  $d$  is given by:

$$\begin{bmatrix} e_1 \\ e_2 \end{bmatrix} = \begin{bmatrix} W_e S & W_e S G W_d \\ W_u K S & W_u T W_d \end{bmatrix} \begin{bmatrix} r \\ d \end{bmatrix} \quad (14)$$

Where  $S = (1 + GK)^{-1}$  is the sensitivity function and  $T = KGS$  is the complementary sensitivity function. The main result of  $H_\infty$  standard problem is: for  $\gamma$  as small as possible, find a stabilizing controller  $K(s)$  such that:

$$\left\| \begin{bmatrix} W_e S & W_e S G W_d \\ W_u K S & W_u T W_d \end{bmatrix} \right\|_\infty < \gamma \quad (15)$$

We can use the optimum  $H_\infty$  controller theory described in order to find an optimal fixed-structure controller. In this work we use the hinfstruct function in order to minimize the  $H_\infty$  norm of the plant with respect to the tunable controller gains. Hinfstruct applies non-smooth optimization to find the free parameters of a prescribed controller structure. The function can be use for simple gain controllers, fixed state-space or transfer function (Apkarian and Noll, 2006).

## 5.2 Proposed design procedure

*Approximation of the time delay.* It is necessary to point out that the controller  $K(s)$  cannot be analytically designed if the time delay involved in the process is treated strictly (Zhang, 1998). Consider a Pade approximation in the form:

$$e^{-\tau s} \approx G_p = \frac{1 - k_1 s + k_2 s^2 + \dots + (-1)^q k_q s^q}{1 + k_1 s + k_2 s^2 + \dots + k_q s^q} \quad (16)$$

where  $q$  is the approximation order to be chosen. The coefficients  $k_i$  depend of  $q$  and  $\tau$  and are determined from a Taylor series expansion of the transcendental function. When an approximation of the time delay is introduced, the plant (1) becomes:

$$G(s)e^{-\tau s} \approx G(s)G_p(s) \quad (17)$$

With the rational transfer function (17) a controller using  $H_\infty$  theory may now be calculated.

*Augmented plant structure.* The Fig. 3 shown an alternative configuration of the observer scheme. Where  $G_O$  represent a subsystem that contains the next elements of the system (20): Transfer function of the stable poles and minimum phase zeros given by:  $\frac{\prod_{l=1}^m (s+b_l)}{\prod_{i=1}^n (s+c_i)}$ , transfer function of the pade-approximation  $G_p$ , the transfer function of the unstable pole  $a_1$  given by:  $\frac{1}{(s-a_1)}$ . While the subsystem  $K_O$  contains: Tunable gains  $g_1, g_2$  and transfer function of the unstable pole  $a_2$  given by:  $\frac{1}{(s-a_2)}$ . An alternative configuration of the controller scheme can be easily derived from a dual procedure of the previous result.

The alternative representations of the observer and controller scheme keeps the same dynamic behaviour with the signals  $\omega, \hat{\omega}, y$  and  $\hat{y}$  of the original proposal shown in Fig. 1 and represent one way to build the augmented system (nominal system + weighting functions).

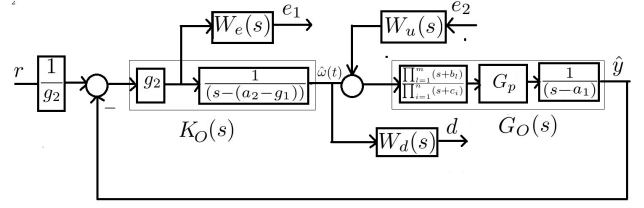

Fig. 3. Closed-loop with the weighting transfer function of the alternative observer scheme representation.

*Weighting functions selection.* The weighting functions  $W_e, W_u, W_d$  are selected taking account the basic requirement of mixed-sensitivity design (Lundstrm et al., 1991). The weighting function  $W_e$  represents the performance objective of the error sensitivity function  $S(s)$ , it should work as a lowpass-filter in order to reduce the error sensitivity in the low frequency range for output disturbance rejection.  $W_e$  is defined in the next form (Skogestad and Postlethwaite, 2005):

$$W_e(s) = \frac{1}{M_s} \frac{s + \omega_b M_s}{s + \omega_b \varepsilon} \quad (18)$$

where  $\omega_b$  is the lowest allowable bandwidth of the system it is chosen close to the minimum required bandwidth.  $M_s$  is the maximum allowable peak for the frequency response of the sensitivity function.

The weighting function  $W_u$  should be a high-pass filter in order to guarantee the stability of the controlled system under diverse operating conditions. The weighting function  $W_u$  is defined as follows:

$$W_u(s) = \frac{1}{\varepsilon_u} \frac{s + \frac{\omega_h}{M_u}}{s + \frac{\omega_h}{\varepsilon_u}} \quad (19)$$

where  $\varepsilon_u > 0$  it must be chosen as a small constant in order ensure good rejection of measurement errors. The pulsation  $\omega_h$  limits the bandwidth and must be chosen sufficiently far from the desired grid frequency for closed loop control.  $M_u$  represent the effort of the controller. The principal effect of the weighting function  $W_d$  is to ensure rejection of disturbances, it is chosen here as a constant function.

*Controller designed using hinfstruct.* The controller is synthesized by hinfstruct method for convergence to a feasible solution until the cost function  $\gamma$  is minimized.

For run the hinfstruct instruction, in addition to provide the augmented plant and the required structure of the controller, it is necessary provide an initial controller as a starting point. The initial controllers values can be selected using the gains where the system (2) is stable. The following procedure is proposed in order to obtain gains  $g_l$  and  $g_2$  such that the closed loop system is stable. The value of the proportional gain  $g_l$  can be stated as follows:

$$g_1 = \frac{1}{\frac{1}{a_2} + \prod_{l=1}^m \frac{1}{b_l} - \prod_{i=1}^n \frac{1}{c_i} - \tau} + \varepsilon$$

$$g_2 = \frac{\prod_{l=1}^m (b_l)}{g_1 \prod_{i=1}^n (a_i)} + \varepsilon$$

with  $\varepsilon$  being a positive real constant. Hence, applying a continuity argument on  $g_1$  and  $g_2$ , is always possible to choose a  $\varepsilon$  small enough such that the gains stabilize the system. The indicated values ensure a stable behaviour of the closed-loop system and represent a good start point of the initial controller in order to find the optimal values of the tunable gains. The values for  $k_1$  and  $k_2$  can be easily derived from a dual procedure of the previous result.

## 6. EXAMPLE

**Example 1:** Application to a linearizing model of CSTR with zero dynamics by numerical simulation. We illustrate the design of the controller through the following example.

Now, consider the example proposed in (Novella-Rodríguez et al., 2014). In this example the flow rate is the manipulated variable and the temperature of the CSTR is the controlled variable. The linearization of the equation assuming a measurement delay of 54 min gives the transfer function model as:

$$G(s) = \frac{-4.7475(s + 3.129)}{(s - 0.5545)(s - 0.09395)(s + 6.394)} e^{-0.9s} \quad (20)$$

The stability condition given in Lemma 2 is satisfied, therefore there exists an observer based structure as shown in the Fig. 1 with proportional gains  $g_1$ ,  $g_2$ ,  $k_1$  and  $k_2$  such that the resulting closed-loop system is stable.

The weighting function  $W_e(s)$  is calculated with the next parameters:  $M_s = 1.2$ ,  $\omega_b = 0.1$ ,  $\varepsilon = 0.0103$ . The weighting function  $W_u(s)$  is calculated with the next parameters:  $M_u = 10$ ,  $\omega_h = 10$ ,  $\varepsilon = 0.0001$ . And  $W_d(s) = 0.001$ .

Following the methodology shown in section 5 and using a Pade-approximation with order  $q = 9$ , the calculated gains for the example 1 are shown in Table 1.

Table 1. calculated gains for the example 1

Gains	Values
$g_1$	816.7051
$k_1$	101.6702
$g_2$	-544.9466
$k_2$	-64.8597

Additionally we compute a full-order  $H_\infty$  controller with the hinfsyn function of the Robust Control Tool-box for the example 1 using the same weight functions and the same order of Pade-approximation in order to make a comparison between the proposed control strategy using hinfstruct like a tool to calculate the tunable gains and hinfsyn instruction to calculate one controller. The full order  $H_\infty$  controller obtained with hinfsyn is an eighth order controller. The simulations are carried out using Matlab©/Simulink.

### 6.1 Frequency response

Fig. 4 show the shape of the complementary sensitivity  $T$ , which also corresponds to the closed loop transfer function.

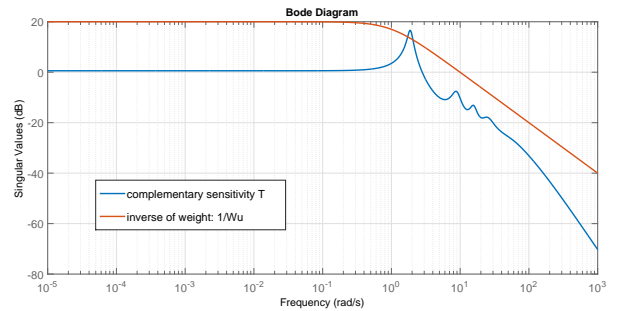

Fig. 4. Frequency response : complementary sensitivity function

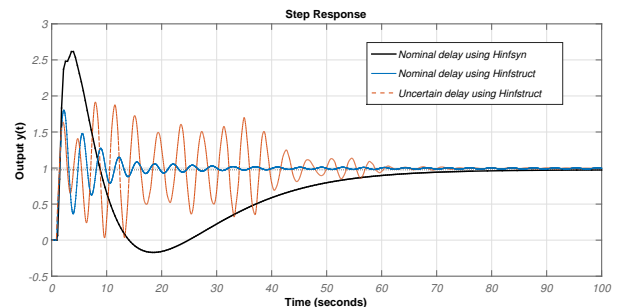

Fig. 5. Closed-loop behavior of the example 1 with a delay uncertainty of 5 percent

This indicates that the selected weighting functions for controller design using hinfstruct have achieved the goal of command tracking.

### 6.2 Time response

Due to the use of a delayed observer in this work, the uncertainties in the time-delay of the plant may cause oscillations or even instability. Fig. 5 shows the effect of delay mismatches between the plant nominal delay and the observer delay. Solid line indicates the simulation with nominal values of the time delay in the plant. The dashed line shows the response of the system when the time-varying uncertain delay is introduced to the process. The time-delay in the plant can be considered as  $\tau(t) = 0.9 + \delta(t)$ , where  $\delta(t)$  is pseudo-random binary signal scaled to a magnitude of 0.05.

The results show that the methodology shown in Section 5 using hinfstruct is significantly faster and provide a minor overshoot than hinfsyn. The error introduced by the rational approximation will not cause instability in the proposed method.

## 7. CONCLUSION

The paper described a control design of an observer based controller scheme that guaranteed the stabilization of delayed systems with two unstable poles,  $n$  stable poles and  $m$  minimum phase zeros using only 4 tunable gains. Based on the  $H_\infty$  control theory the controller gains are tuned using hinfstruct optimization. The conditions that guarantee the stability of the closed-loop system are derived in terms of the upper limit of time delay size and the poles and zeros position.

Parameter uncertainty has been considered in the numerical simulations and demonstrate the effectiveness of the method. Our test demonstrates that hinfstruct together with the control strategy proposed is faster and present a minor overshoot when compared to hinfsyn for the example used.

## 8. BIBLIOGRAPHY

### REFERENCES

- Apkarian, P. and Noll, D. (2006). Nonsmooth optimization for multidisk h synthesis. *European Journal of Control*, 12(3), 229 – 244.
- Bequetten, B.W. (2003). *Process Control. Modeling, Design and Simulation*. Prentice Hall Internacional.
- Bouزيد, A.M., Sicard, P., Chriti, A., Bouhamida, M., and Benghanem, M. (2015). Structured hdesign method of pi controller for grid feeding connected voltage source inverter. In *2015 3rd International Conference on Control, Engineering Information Technology (CEIT)*, 1–6.
- H, B. (1991). *Automatic control of aircraft and missiles*. Wiley-interscience publicationl.
- Kailath., T. (1980). *Linear Systems*. Prentice Hall, USA.
- Kwak, H.J., Sung, S.W., and Lee, I.B. (2000). Stabilizability conditions and controller design for unstable processes. *Chemical Engineering Research and Design*, 78(4), 549 – 556.
- Lee, S.C. and Wang, Q.G. (2010). Stabilization conditions for a class of unstable delay processes of higher order. *Journal of the Taiwan Institute of Chemical Engineers*, 41(4), 440 – 445.
- Lundstrm, P., Skogestad, S., and Wang, Z.Q. (1991). Performance weight selection for h-infinity and -control methods. *Transactions of the Institute of Measurement and Control*, 13, 241–252.
- Novella-Rodrguez, D., del Muro-Cullar, B., and Sename, O. (2014). Observer based scheme for the control of high order systems with two unstable poles plus time delay. *Asia-Pacific Journal of Chemical Engineering*, 9.
- Skogestad, S. and Postlethwaite, I. (2005). *Multivariable feedback control: Analysis and Design*. John Wiley.
- Vazquez-Rosas, C., del Muro-Cullar, B., and MARquez Rubio, J. (2017). Stability conditions for unstable high order systems with minimum-phase zeros plus time delay.
- Wang, Q.G., Lee, T.H., and k.Tan, K. (1999). *Finite-Spectrum Assignment for Time-Delay Systems*. Springer-Verlag, London.
- Wu, L., Lam, H.K., Zhao, Y., and Shu, Z. (2015). Time-delay systems and their applications in engineering 2014. *Mathematical Problems in Engineering*, 2015, 1–3.
- Zhang, W.D. (1998). Analytical design methods for process control.