



HAL
open science

Development of a microfluidic preconcentration device for sub-ppb level detection of BTEX

Irene Lara-Ibeas, Alberto Rodríguez-Cuevas, Vincent Person, Stéphane Colin,
Lucien Baldas, Stéphane Le Calvé

► To cite this version:

Irene Lara-Ibeas, Alberto Rodríguez-Cuevas, Vincent Person, Stéphane Colin, Lucien Baldas, et al..
Development of a microfluidic preconcentration device for sub-ppb level detection of BTEX. European
workshop on Low-cost Sensors and Microsystems for Environment Monitoring, May 2019, Toulouse,
France. hal-02149549

HAL Id: hal-02149549

<https://hal.science/hal-02149549v1>

Submitted on 6 Jun 2019

HAL is a multi-disciplinary open access archive for the deposit and dissemination of scientific research documents, whether they are published or not. The documents may come from teaching and research institutions in France or abroad, or from public or private research centers.

L'archive ouverte pluridisciplinaire **HAL**, est destinée au dépôt et à la diffusion de documents scientifiques de niveau recherche, publiés ou non, émanant des établissements d'enseignement et de recherche français ou étrangers, des laboratoires publics ou privés.

Development of a microfluidic preconcentration device for sub-ppb level detection of BTEX

Irene Lara-Ibeas^{1,2}, Alberto Rodríguez-Cuevas³, Vincent Person³, Stéphane Colin², Lucien Baldas², Stéphane Le Calvé^{1,2}

¹ICPEES, Université de Strasbourg, CNRS (UMR 7515) France

²Institut Clément Ader (ICA), Université de Toulouse, INSA, ISAE-SUPAERO, Mines-Albi, UPS, Toulouse, France,

³In'Air Solutions, 25 Rue Becquerel, 67087 Strasbourg, France

INTRODUCTION

Nowadays, **indoor air pollution** has become a major concern for society due to its significant impact on human health leading to **3.8 million premature deaths** every year [1]. Among the broad variety of contaminants identified in indoor air, **benzene, toluene, ethylbenzene and xylenes (BTEX)** require particular attention since BTEX exposure has been associated with the development of numerous pathologies including asthma, kidney damage or neurological problems. In the case of **benzene**, more serious effects such as **leukaemia** had led the European Union to establish in 2013 a threshold limit value of **5 g m⁻³ (1.6 ppb)** [2] for this pollutant in public buildings. In France, this limit was decreased to **2 g m⁻³ (0.6 ppb)** in 2016. Hence, in order to check if indoor air quality (IAQ) is in accordance with the recent legislation, **on-site rapid and sensitive analysis** is required.

FABRICATION

Design of the preconcentration device

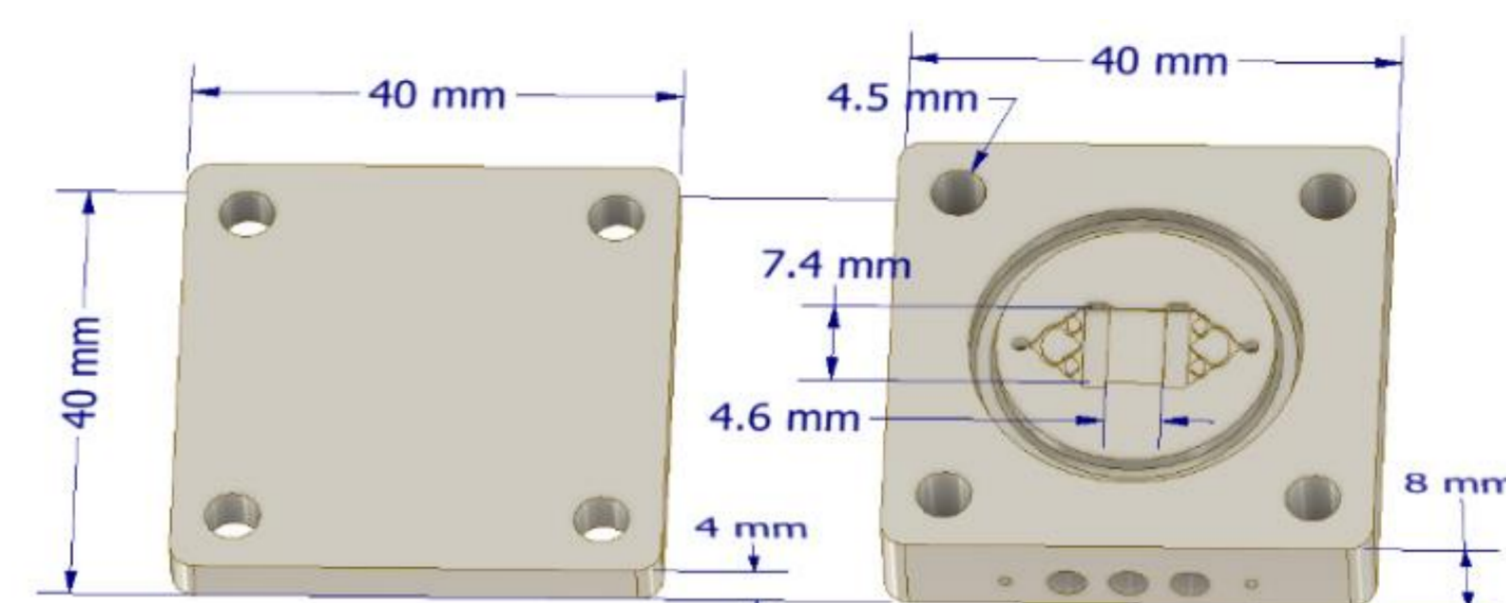

Material: aluminium

Mass: 54.9 g

Adsorbent: 5.8 mg of Basolite® C300

Heating system: 3 heating cartridges (70 W)

Temperature ramp: 150 °C/min

Microfluidic cavity

Symmetrical manifold fluidic system to promote a **uniform flow** distribution through the adsorbent bed.

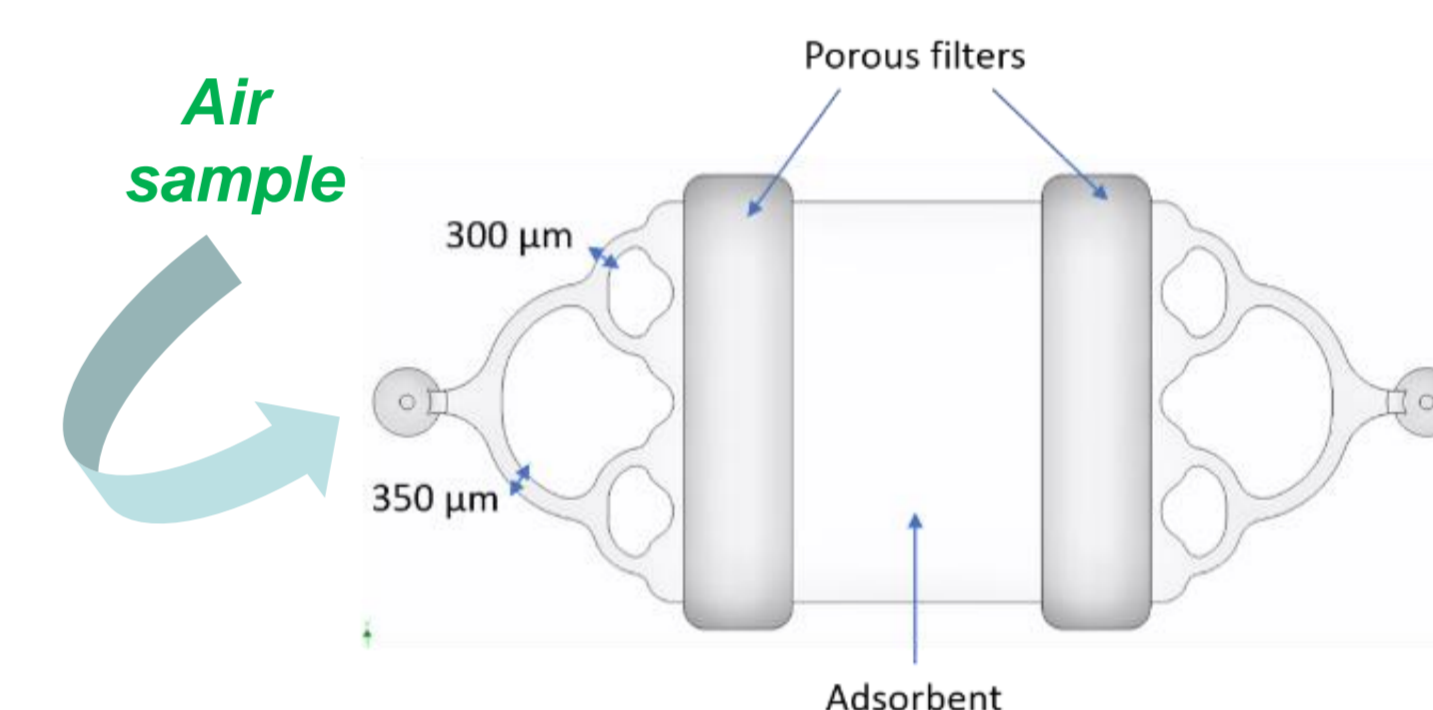

RESULTS

The signal obtained with the **GC prototype** equipped with a **preconcentrator (PC)** is clearly improved:

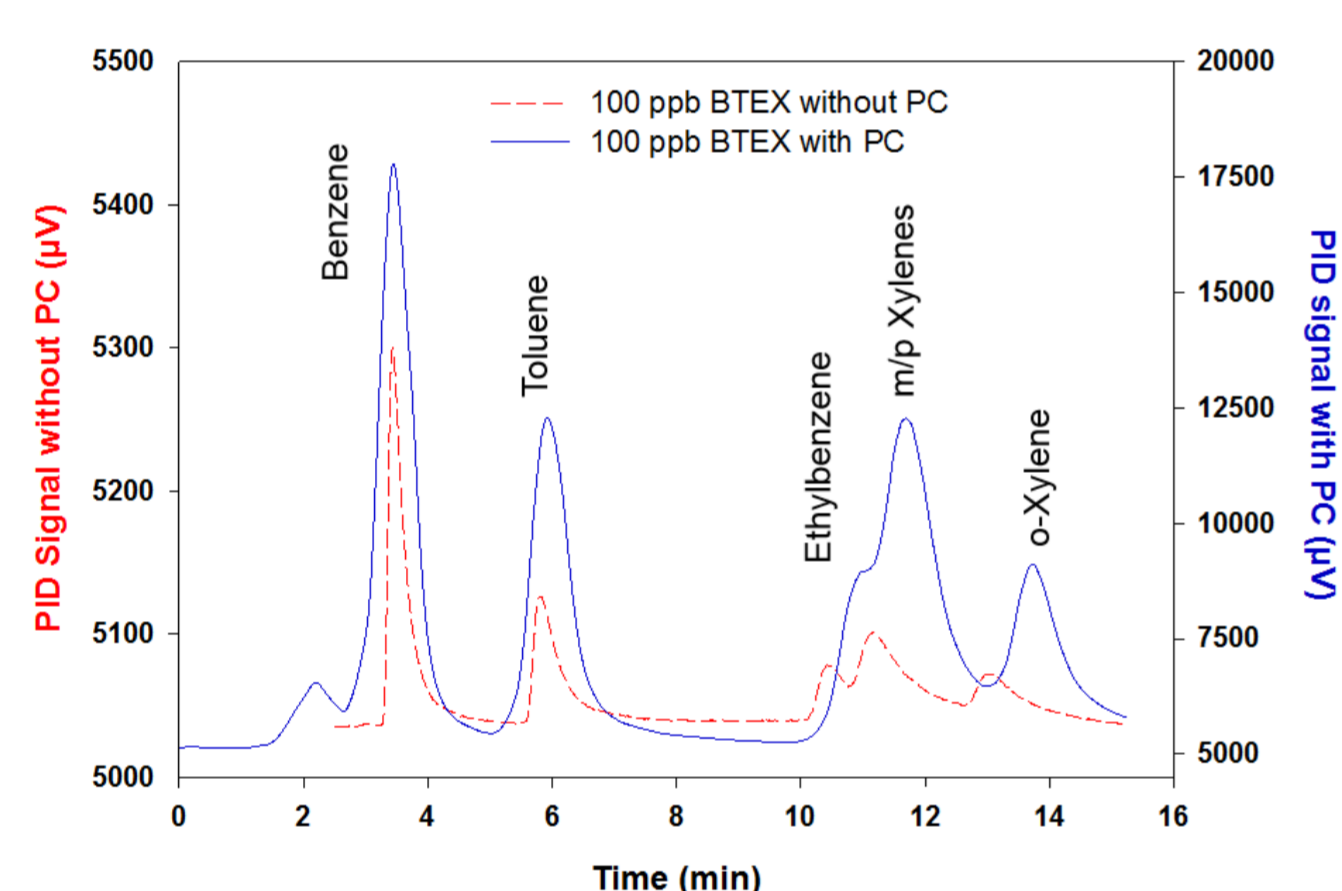

Numerous experiments were conducted to evaluate the performances of the new **GC prototype** :

Repeatability

To evaluate the repeatability of the device, **ten 20 mL samples containing 100 ppb of BTEX** were consecutively injected. Between two consecutive injections, a cleaning step was conducted. **Relative standard deviations (RSD)** of peak area and retention time were calculated:

RSD (%)	Benzene	Toluene	Ethylbenzene	m/p Xylenes	o-Xylene
Retention time	0.5	0.7	1.7	1.4	1.4
Peak area	3.8	6.3	11.0	14.7	13.4

Linearity

Different volumes varying from 5– 80 mL of a 100 ppb standard gaseous mixture of BTEX were injected in duplicate at a fixed flow rate of 5 mL/min.

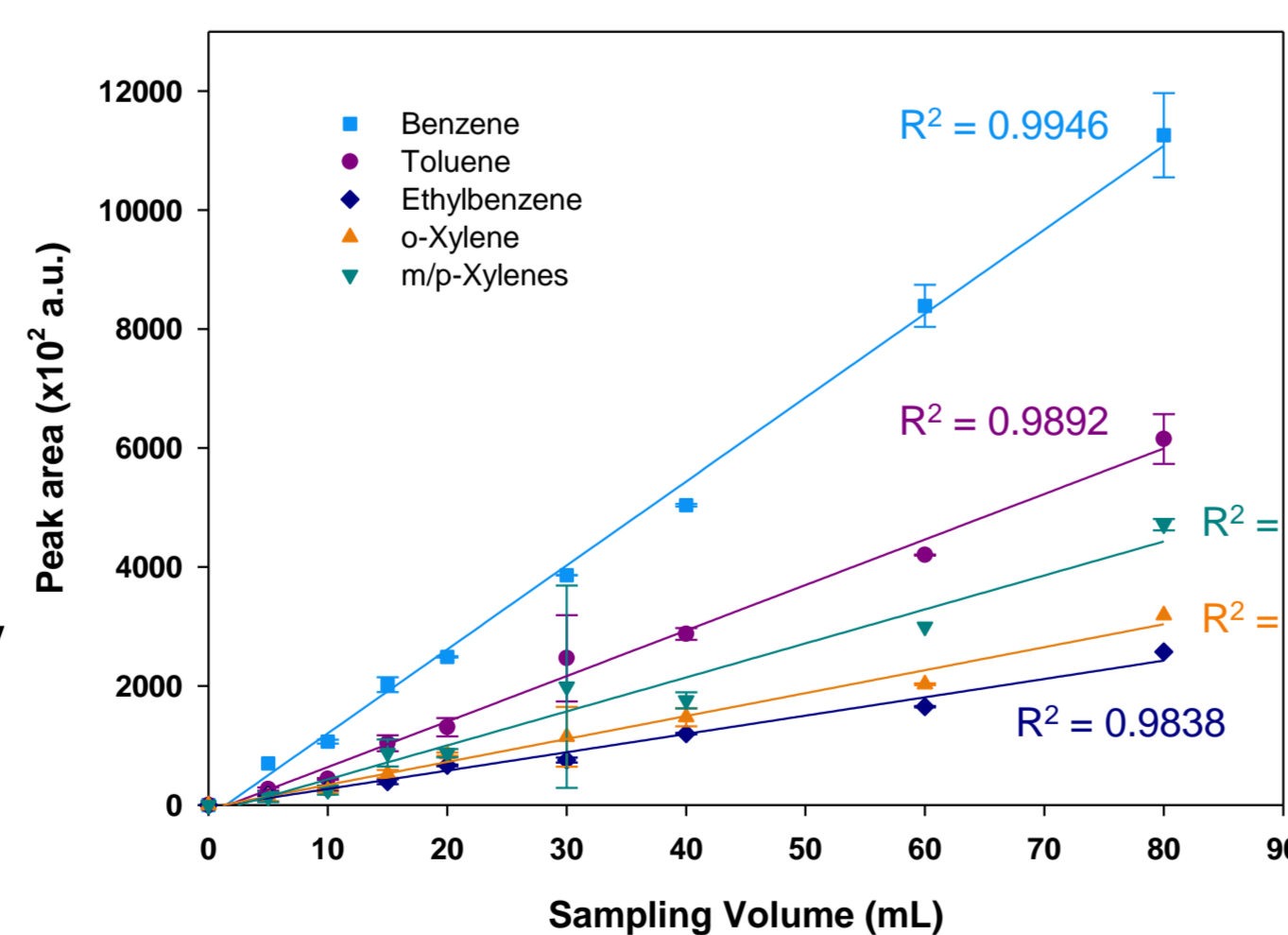

Peak areas increase proportionally with the corresponding sampling volumes

OBJECTIVES

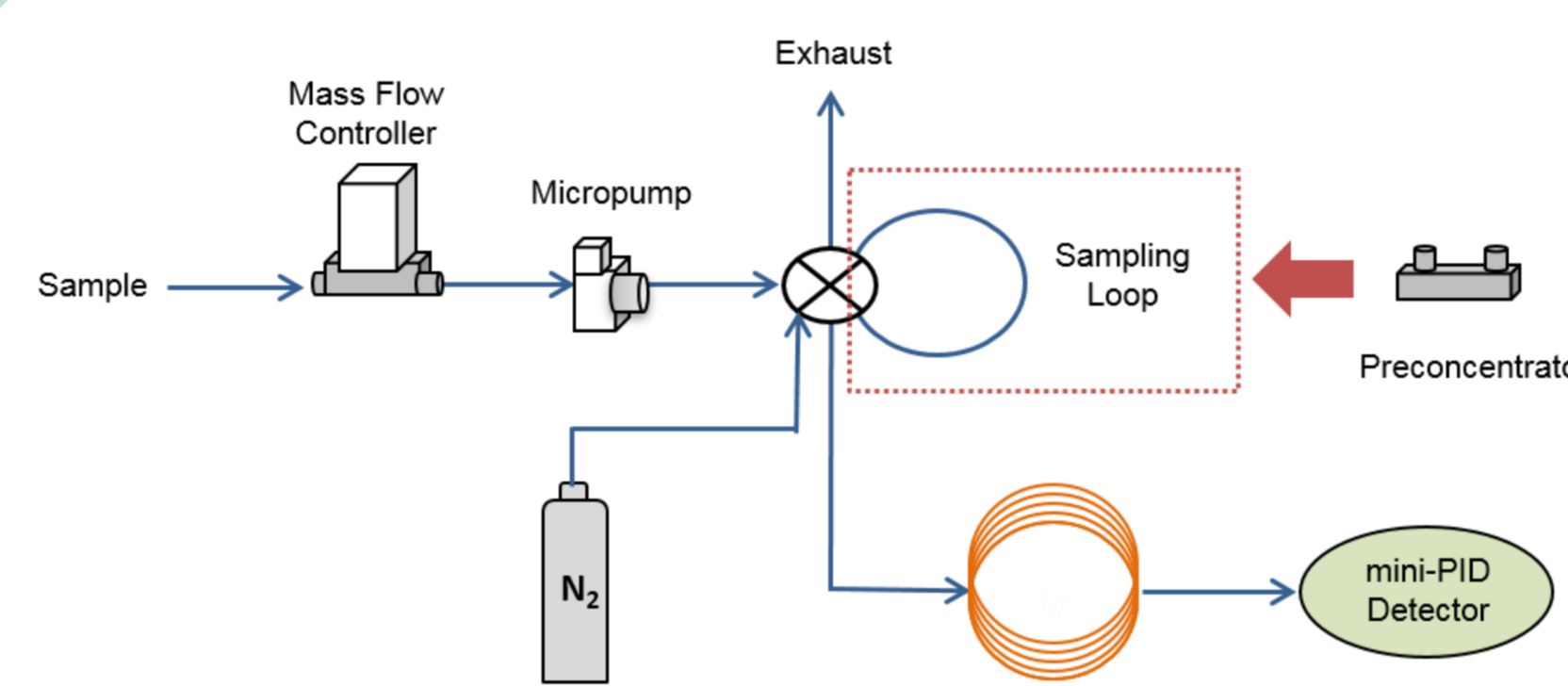

Schematic diagram of miniaturized Gas Chromatograph (GC) developed by our team [3]

In this work, the 200 µL GC sampling loop has been replaced by a preconcentrator to improve the **limit of detection (LOD)** of the portable GC to **sub-ppb levels** keeping:

- High time resolution (10 – 20 min)
- Low gas carrier consumption (< 3 mL min⁻¹)
- Portability (weight < 5 kg)

Calibration curves and LOD

Calibration was performed using different gaseous concentrations of the targeted compounds ranging from **2.5–100 ppb**:

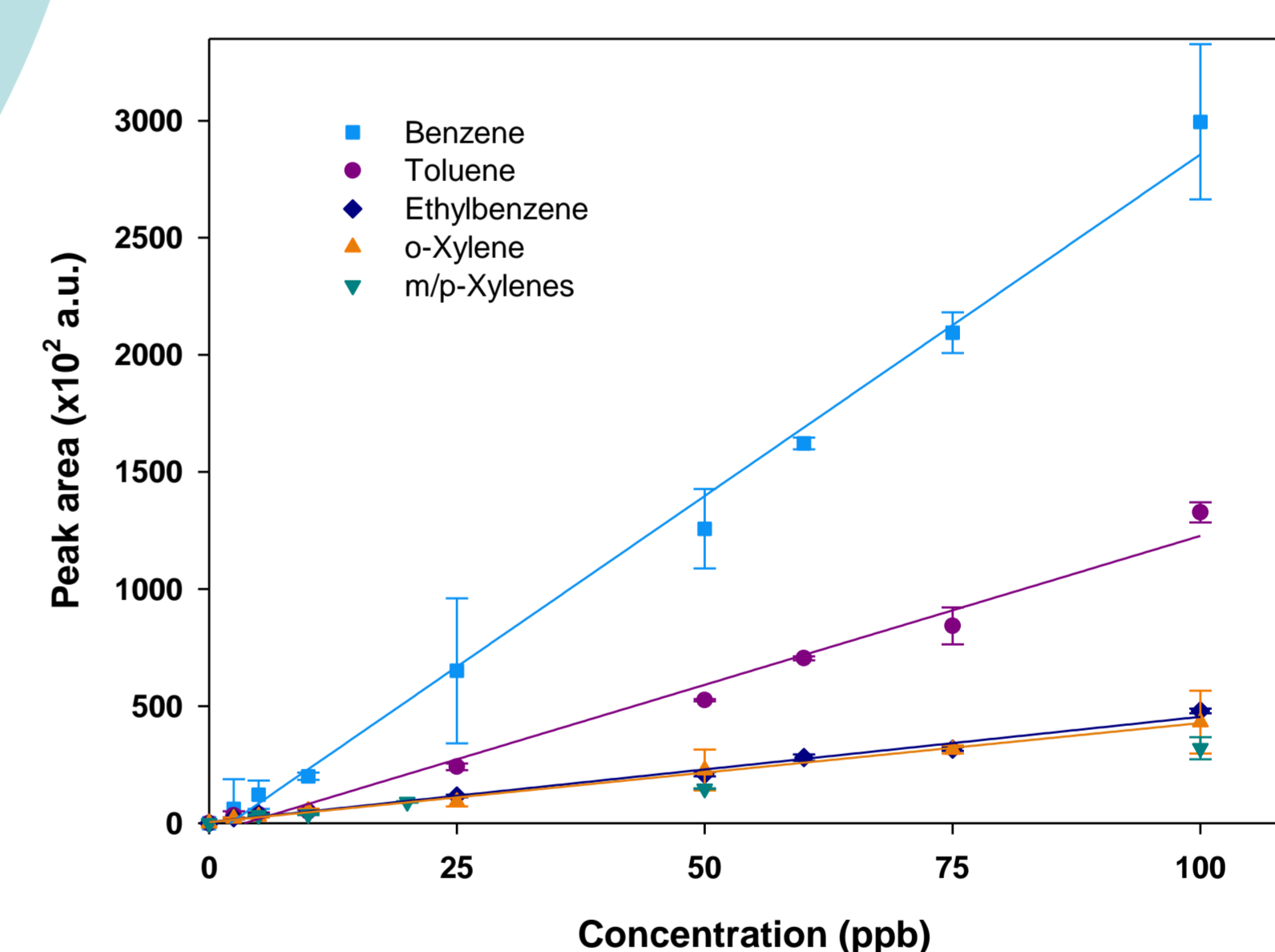

The peak area increases linearly with the injected concentrations

Compound	Calibration Equation	R ²	LOD 1 (ppb) (This Work)	LOD 2 (ppb) [24]	Ratio LOD 2 / LOD 1
Benzene	y = 2828.2 x	0.9913	0.20	0.72	3.6
Toluene	y = 1206.3 x	0.9777	0.26	1.16	4.46
Ethylbenzene	y = 454.2 x	0.9895	0.49	2.10	4.40
m/p-Xylenes	y = 311.9 x	0.9959	0.80	1.40	1.75
o-Xylene	y = 427.0 x	0.9949	1.70	2.63	1.55

LOD were calculated from **S/N = 3** for the two lowest injected concentrations (2.5 and 5 ppb)

CONCLUSIONS AND PERSPECTIVES

We reported the development of a **compact GC prototype** for near-real time BTEX analysis in **sub-ppb range**. Using a 20 mL sampling volume, BTEX analysis was conducted in **19 min** and corresponding **detection limits of 0.20, 0.26, 0.49, 0.80 and 1.70 ppb** were calculated for **benzene, toluene, ethylbenzene, m/p-xylenes and o-xylene**, respectively. Considering the extremely low detection limit achieved by this prototype, it becomes possible to extend its use to other fields of application such as the food industry, early cancer diagnosis or explosives detection, by measuring other VOCs families and/or by changing the nature of adsorbent. Several improvements can be proposed for future versions of the compact GC including **miniaturization of the preconcentrator and the separation column** on the one hand in order to achieve faster heating, which would lead to faster desorption and then to thinner chromatographic peaks and on the other hand, to reduce the total analysis time. In addition, the miniaturization of both components will reduce the energy consumption of the prototype, increasing its **autonomy** and improving its **portability**.