



**HAL**  
open science

## Site wide heat integration in eco-industrial parks considering variable operating conditions

Christina Kachacha, Alaa Farhat, Zoughaib Assaad, Cong Toan Tran

### ► To cite this version:

Christina Kachacha, Alaa Farhat, Zoughaib Assaad, Cong Toan Tran. Site wide heat integration in eco-industrial parks considering variable operating conditions. *Computers & Chemical Engineering*, 2019, 126, pp.304-320. 10.1016/j.compchemeng.2019.04.013 . hal-02148706

**HAL Id: hal-02148706**

**<https://hal.science/hal-02148706v1>**

Submitted on 22 Oct 2021

**HAL** is a multi-disciplinary open access archive for the deposit and dissemination of scientific research documents, whether they are published or not. The documents may come from teaching and research institutions in France or abroad, or from public or private research centers.

L'archive ouverte pluridisciplinaire **HAL**, est destinée au dépôt et à la diffusion de documents scientifiques de niveau recherche, publiés ou non, émanant des établissements d'enseignement et de recherche français ou étrangers, des laboratoires publics ou privés.



Distributed under a Creative Commons Attribution - NonCommercial 4.0 International License

# Site wide heat integration in eco-industrial parks considering variable operating conditions

*Christina Kachacha<sup>a</sup>, Alaa Farhat,<sup>b</sup> Assaad Zoughaib<sup>c</sup>, Cong Toan Tran<sup>d</sup>*

*a Mines ParisTech, PSL Research University, CES- Centre d'efficacité énergétique des systèmes, Z.I. Les glaises- 5, rue Léon Blum, 91120 Palaiseau, France, christina.kachacha@mines-paristech.fr*

*b Mines ParisTech, PSL Research University, CES- Centre d'efficacité énergétique des systèmes, Z.I. Les glaises- 5, rue Léon Blum, 91120 Palaiseau, France, alaasfarhat@gmail.com*

*c Mines ParisTech, PSL Research University, CES- Centre d'efficacité énergétique des systèmes, Z.I. Les glaises- 5, rue Léon Blum, 91120 Palaiseau, France, assaad.zoughaib@mines-paristech.fr*

*d Mines ParisTech, PSL Research University, CES- Centre d'efficacité énergétique des systèmes, Z.I. Les glaises- 5, rue Léon Blum, 91120 Palaiseau, France, cong-toan.tran@mines-paristech.fr*

## **Abstract:**

One powerful way to improve energy efficiency in industry is through Heat Integration. The heat recovery application was extended to multiple processes in eco-industrial parks offering important energy efficiency improvements. Many methodologies have been developed to apply the side wide heat integration concept; it sets energy target for the heat exchange that can be achieved between the processes using a common utility system. Nevertheless, deviations of operating parameters such as supply and target temperatures and flow rates from nominal values are an everyday reality, thus the assumption of specific operation modes of the sites in heat integration methodologies that have been developed is not sufficient to justify investments especially with all the interactions between the interdependent processes that can occur. Consequently, any suggested design of heat transport network must be able to operate in all encountered operating conditions. The present work uses a mathematical optimization approach based on a mixed integer linear programming MILP model for the synthesis of heat exchange and transport networks between multiple processes covering energetic and economic aspects and employing the multi period approach to represent the variability of streams. The methodology is illustrated by applications to two case studies of virtual eco-industrial parks.

## **Keywords:**

Energy efficiency, heat integration, eco-industrial Park, multi-period approach, MILP

## **1 Introduction**

The increasing demand for energy associated with fossil fuels consumption, mainly related to the economic and demographic growth and the threat of global warming due to greenhouse gas emissions encourage global efforts in industries to increase their energy efficiency. At first, process heat integration strategies have been developed extensively as they bring solutions to industrial energy efficiency problems with methods for heat recovery by connecting hot and cold streams of a process thus achieving a reduction in the net energy consumption at a single process scale. Several methods have been reported to solve the problem of the synthesis of heat exchanger network (HEN) for an optimal selection of the matches for heat exchange between hot and cold streams of the process in order to reduce the overall external heating and cooling utilities. These methods are divided into heuristics based on thermodynamic approaches and mathematical optimization sequential and simultaneous design approaches [1], [2], [3] [4] to consider the tradeoff between energy and cost of units and heat exchangers. The developed methods for HEN were extended to take into consideration variations in operating conditions which may be encountered for several reasons (seasonal variations, change in product demand etc.) by adopting the multi period operations in the sequential synthesis methods [5] , [6] and in simultaneous synthesis approaches [7], [8]. Recently an extended synthesis method was developed; the simplified stage wise superstructure of Yee and Grossman [3] for the optimization of the heat exchanger network at the process scale was extended to include multi period process stream parameters and multiple options of utilities while including renewable energy sources

[9]. On the other hand, in [10] a MINLP model was developed for a simultaneous process synthesis and heat integration of unclassified process streams by using a classification binary variables to represent the hot/cold stream.

Lately, further developments have focused on exploring energy collaboration between closely located industrial sites thus forming an eco-industrial park. In fact, heat recovery between multiple processes can offer additional energetic and economic efficiency improvements to what is obtained at the process scale. In this perspective, the concept of the extension of Heat integration application from process scale to total site scale was proposed originally by Linhoff and Dhole [11] to provide energy targets for heat recovery between multiple plants and to design the utility systems to satisfy the heating and cooling demand of the processes. The Total site analysis(TSA) is based on a graphical tools to target the amounts of excess heat generated from one process that can be delivered to another process with a heat deficit using a common network ( e.g. steam, hot water, hot oil). For this evaluation, a combination of grand composite curves of the individual processes is used to plot total site profiles and thus depicting the total heat surplus available and the total heat deficit of the processes in a total site.

Varnabo et al. in [12] modified the traditional Total site targeting by specifying individual DT<sub>min</sub> values for integrated processes and for the heat exchange with the site utilities which may provide a better estimation of heat recovery targets and more appropriate evaluation of tradeoff between capital cost and energy gain. The energy targeting procedure was developed through mathematical programming approaches using in [13] LP and MILP models to optimize the location of the tertiary network. Hackl et al. in [14] applied TSA for heat integration in a chemical cluster in Sweden and have shown the benefits of energy collaboration between different plants to improve energy efficiency. Also, this method was applied on a Japanese large scale steel plant by Matsuda and al. in [15] where they identified a large amount of energy savings potential. Another application to TSA was developed by Bandyopadhyay et Al. [16] to estimate the cogeneration potential of the site using the site utility grand composite curves. At first, the TSA concept was applied on industrial processes; however recently Perry et Al. [17] extended its application to include processes from other sectors: residential, business, services and agriculture termed as Locally Integrated Energy Sectors LIES. Further extension to TSA are proposed by [18]; they incorporate renewable energy and account for the variation of heating and cooling demands; they used time slices to represent the variation and include heat storage in the heat cascade principle. A review of the methodologies for energy targeting using the Total site heat integration that are based on Pinch analysis and mathematical programming methods was presented in [19] and suggestions are proposed to increase the integration by including renewables energy resources. In addition, in [20] , the authors introduced a new approach for total site energy integration where the heat can be used to generate cooling using absorption chiller and electric compression chiller. Chew et Al. in [21] listed the industrial issues in the use of TSA that can affect the implementation of the heat integration in a total site like: operational, design and economic issues and developed a matrix to weight the impact of these issues using an heuristic approach. Liew et al, [22] proposed four total site sensitivity tables as a tool to assess the effect of operational changes and variations like plant shutdowns on utility requirement. Process modifications through an extension of the plus minus principle to total site was studied to maximize energy saving of the multiple plants energy integration in [23] and to target decreasing the capital cost of heat transfer units [24]. In [25] the conventional method that uses the total site profile to set the energy targets based on the heat excess and heat deficit of the processes was improved and a new realistic targeting approach with lower targets is proposed; the latter includes isothermal and non-isothermal common utility system .

All the previously mentioned methods both thermodynamic and mathematical programming approaches were useful for establishing energy targets for the heat recovery thus a minimum heating and cooling utilities for the total site. However, it must be extended to take into account the heat exchangers areas and thus the associated capital costs particularly for indirect heat exchange using intermediate recovery loops that requires the installation of two heat exchangers one at the site source and the other at the site sink. In addition, the pipeline required for the heat transport and the connections between the processes and the utility system have to be included in developed methods.

Therefore a more realistic evaluation of the tradeoff between the energetic gain of heat recovery and the investment costs can be achieved.

In [26] the authors developed a convex nonlinear programming optimization model with a piecewise relaxation to reduce the computational time for the design of a heat recovery loop that include the cost of heat exchangers, piping and pumping as an new approach for low grade heat integration between multiple plants. Recently Farhat [27] proposed a methodology based on the exergy minimization for indirect heat integration between multiple processes while simultaneously including multiple energy conversion systems. The methodology was completed by an economic feasibility evaluation that includes heat exchanger cost and the piping network associated with the heating network.

On the other hand, it is worth stating that most of the developed tools, energy targeting methodologies or the mathematical programming approaches used fixed operating conditions to design a configuration of the heat transport network that is useful for operation under nominal parameters of the processes characteristics. Nevertheless, deviations of operating parameters such as supply and target temperatures and flow rates from nominal values may occur; these variations of the properties of processes that can be caused by economic factors, weather conditions, technical issues or maintenance operations can deprive the network of its economic and energetic performance especially with the complexity of the installed heat integration system at this scale that include major interactions between different industrial actors. Consequently, including this aspect of variability at the design phase is fundamental in order to suggest a design of heat transport network that is able to operate effectively in all encountered operating conditions. To address this issue and complete the existing methodologies, the multi period approach is adopted to represent the variations of the operating conditions. Inspired from the use of the multi period approach in process scale HEN design, the latter will be used to solve the problem of operating conditions change in heat integration problems at the total site scale. In fact, this approach allows the representation of the variations and fluctuations in the operating conditions that can be encountered by a series of different set of static conditions as input for the model. The optimization model will search simultaneously in all the integrated periods to establish an optimal network from the energy and economic point of view. This contribution enable the integration of the variability at the design phase in order to suggest a design of heat transport network that is able to operate effectively in all encountered operating conditions.

Therefore, the aim of this work is to develop a simultaneous model for a more complete synthesis of the heat transport network between multiple processes feasible for each period with minimum total annual cost consisting of utility cost, heat exchanger cost, piping cost and pumping cost. In particular, the following issues are to be addressed and to be considered during the development of the model:

- Different set of variations in the operating conditions are considered using the multi period approach.
- The temperatures of the transport networks are the key variables to be optimized
- A superstructure of the heat exchangers installed between the selected streams and the heating network to establish the exchange.
- Hydraulic aspects that include the pipe network to be installed between the plants by taking into account the geographical placement of the processes. This extension is important because it can represent more realistic tradeoff between the capital cost and the energetic gain since the length of the pipeline has a significant impact on the capital cost.

Mathematical optimization approach based on a mixed integer linear programming (MILP) model is developed because it represents the complex problem in a systematic way by decomposing it into a set of equations and by including specific features in the objective function to be optimized. These equations describe the system's operation, constraints and limits to which the variables are subjected to. Although, the equations are not all linear, the choice of a linear programming formulation guarantees a higher numerical robustness and a convergence of the solution. Therefore non linear problem's constraints must be linearized which increases the difficulty in the problem formulation.

The equations of the model are written in the Gnu Mathematic Programming Language (GMPL) language, CPLEX is used as solver for this optimization problem.

The multi-period methodology is tested on two literature case studies. The examples are used to demonstrate the capability of the model to include variations in the operating conditions and to characterize this variation with a specific duration instead of using nominal parameters in the design phase. The model investigates the technical and economical feasibility of the installation of recovery networks that is able to operate in the defined periods. The user can specify the variations for each process and include it as conditions within the periods. In this paper, the examples are extracted from the literature review where they were used for heat integration at the total scale using nominal parameters. In order to show the model capabilities, additional random variations for the operating conditions of the processes were chosen to demonstrate the capability of the model presented in this paper.

## 2 Mathematical Formulation

The proposed strategy aims to solve a MILP optimization model for multi-period multi-plant indirect heat integration using intermediate transport networks whose mathematical formulations is presented in this section. This model is adapted from the MILP model proposed by Farhat [28]. In this model, the non linear equations are linearized by a certain number of assumptions. The temperature of the intermediate network is a key variable for the heat integration between multiple processes to be optimized. A unique discrete temperature scale is built using a fixed step defined by the user in order to obtain a liner formulation of the problem which gives high robustness of the solution. This discretization increases the solution time but allows a more precise and accurate optimal solution. A small set of temperatures limits the choice of the network's temperature obtained and improving the discretization increases the calculation time. In addition, the binary variables are used for heat exchanger's areas and velocity at each pipe. These binary variables are added to identify a unique interval characterized by an upper and lower bound where the cost function and the hydraulic model are linearized. This linearization effect to the calculation accuracy has been discussed by Farhat paper. Here below the adapted model formulation is summarized.

The eco industrial park consists of a number of processes (*groups*) where each individual process ( $m \in groups$ ) own a set of hot process streams and cold process streams ( $o \in streams_m$ ) to be cooled or heated from its supply temperature  $T_{in,o}$  to its target temperature  $T_{out,o}$ , the streams are also characterized by a heat capacity flow rate (CP) and a minimum temperature difference  $\Delta T_{min}$  for the heat exchange between the streams within each process. Each period ( $p \in P$ ) has its own set of streams characteristics in order to represent the variability of these parameters using the multi period approach. It is noted that in the chosen approach multi process heat integration implementation is focused on without taking into account the full integration of the plants.

First of all, a global unique temperature scale in decreasing order is built using shifted input and target temperatures of hot (equations 1) and cold streams of each process (equations 2) to assume that all streams can take part in the internal heat exchange of the process and all streams have the ability to exchange with a certain tertiary network. The N different temperatures obtained are sorted in descending order to get N-1 intervals of the scale.

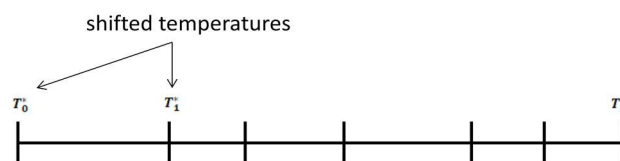

Figure 1: Initial temperature scale

For hot streams

$$T_{in}^* = T_{in} - \frac{\Delta T_{min}}{2}$$

$$T_{out}^* = T_{out} - \frac{\Delta T_{min}}{2}$$
(1)

For cold streams

$$T_{in}^* = T_{in} + \frac{\Delta T_{min}}{2}$$

$$T_{out}^* = T_{out} + \frac{\Delta T_{min}}{2}$$
(2)

It should be noted that the network temperature is a variable to be optimized and different constraints, such as energy balance or heat exchanger surface calculation, are non linear with regard to temperature. In order to keep the model linear, it is necessary to create a set of predefined values from which the network temperature can be chosen. To obtain this set of values, sub-divisions is introduced between two consecutives temperature of the initial scale (Figure 1) so that the temperature interval becomes smaller than a step  $\Delta T$  fixed by the user (see Figure 2). With smaller  $\Delta T$ , higher accuracy of the model can be attained, but the calculation time becomes longer.

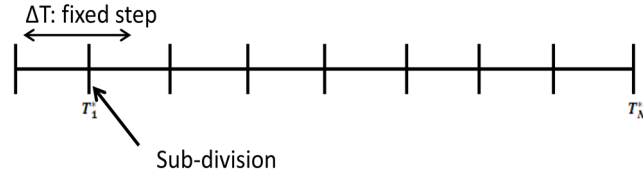

**Figure 2: Final temperature scale**

Heat integration between plants is considered indirect through the installation of at least one network to extract the excess heat from a plant called source and deliver it to the sink plant with heat deficit using intermediate fluids such as steam, hot water or oil. At high temperatures steam is widely used for the transfer of latent heat at a fixed temperature. At lower temperatures heat exchange can be done using liquids for the transfer of sensible heat and more energy recovery can be accomplished. In our model, both types of networks (steam and liquid) are considered and the deciding factor between the two options is process characteristics that point towards the more suitable solution.

Each network is characterized by its temperature(s) that is variable to be optimized by the model; the liquid networks have an upper ( $Tu_{net}$ ) and lower temperature ( $Tl_{net}$ ) therefore, the combination of two temperatures from the original temperature range is used to define the possible operating temperatures; whereas for steam networks those values are assumed identical ( $T_{net}$ ) by considering only the latent heat exchange and similarly the definition of the possible operating temperatures are deduced from the temperature set used previously to build the temperature scale.

Yet, for a realistic exchange between the streams and the intermediate networks, a minimum temperature difference  $\Delta T_{net}$  between the operating temperatures of any process' stream and those of the network is required twice, once at the plant which provides heat to the network and the other is at the plant which gains heat from the network. For any possible combination of heat exchange between a specific network's temperature ( $net \in networks$ ) and a specific temperature interval ( $n \in N - 1$ ) of process stream equations (3) and (4) must be respected when heat is supplied from the network to the stream, when a network withdraws heat from a plant at an interval ( $n$ ) equations (5) and (6) must be respected.

Liquid network

$$Tu_{net} \geq T_n + \Delta T_{net}$$

$$Tl_{net} \geq T_{n+1} + \Delta T_{net}$$

$$T_n \geq Tu_{net} + \Delta T_{net}$$

$$T_{n+1} \geq Tl_{net} + \Delta T_{net}$$

Steam network

$$T_{net} \geq T_n + \Delta T_{net}$$
(3)

$$T_{net} \geq T_{n+1} + \Delta T_{net}$$
(4)

$$T_n \geq T_{net} + \Delta T_{net}$$
(5)

$$T_{n+1} \geq T_{net} + \Delta T_{net}$$
(6)

The intermediate fluid can exchange heat with all the cold streams in sink plant or all the hot streams in source plant, thus heat exchanger networks superstructure is needed also to be optimized. In other hand, transferring and recovering heat requires heat exchangers of reasonable size. To be able to calculate the area of the exchangers and to keep the model linear, a pre-calculation of the logarithmic mean temperature difference LMTD is executed for all feasible heat exchange options; the latter includes all heat exchange combinations between possible network installation and all possible temperature intervals  $nn$  and  $ns$  of each stream (o). Equation (7) and (8) represents the calculation of LMTD in case of a cold/hot stream exchanging heat between two temperature intervals ( $nn$  and  $ns$ ) with a liquid network (7) and steam network (8).

$$lmtd_{p,net,m,nn,ns,o} = (Tu_{net} - T_{p,m,nn,o}) - (Tl_{net} - T_{p,m,ns,o}) / \ln((Tu_{net} - T_{p,m,nn,o}) / (Tl_{net} - T_{p,m,ns,o})) \quad (7)$$

$$lmtd_{p,net,m,nn,ns,o} = (T_{net} - T_{p,m,nn,o}) - (T_{net} - T_{p,m,ns,o}) / \ln((T_{net} - T_{p,m,nn,o}) / (T_{net} - T_{p,m,ns,o})) \quad (8)$$

( $\forall p \in P, \forall m \in groups, \forall o \in streams_m, \forall net \in Networks, \forall nn, ns \in N - 1$ )

It should be noticed that the intervals  $nn, ns$  are bounded by the specific stream's inlet  $T_{in}$  and outlet temperatures  $T_{out}$

In addition, the model takes into consideration geographical aspects. The pre-planned geographical location of each process as well as the potential pipe routings allows defining a set of nodes  $NODES$  with a specification of the geographical coordinates of each one ( $X_{node}, Y_{node} / node \in NODES$ ). The user defines a set of possible paths ( $path \in PATHS$ ) that connects two nodes and each one can be characterized by its length ( $l_{path}$ ) that is pre calculated using nodes coordinates. The model will choose the best routing for the heat transport network. In addition, in each path an assumption of positive flow direction from node with lower index to the node with higher index of the path. Therefore, the sign of the variable representing heat flowing in a certain path  $qch_{path}$  denotes the flow direction of the flow in the specified path. Figure 3 shows three possible piping paths to link two processes A and B that are presented at node 1 and 2. These parameters will be used in hydraulic modeling of the piping system.

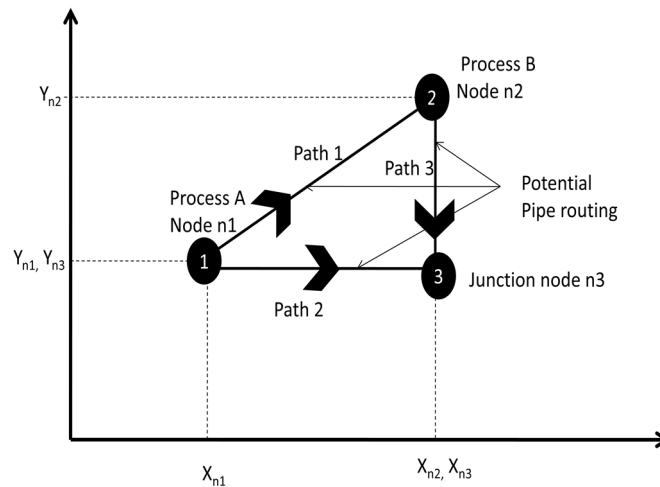

Figure 3: Geographical representation

## 2.1 Energy Balance in each temperature interval

As previously mentioned, heat integration within each plant  $m$  for each temperature interval  $n$  is assumed accomplished. Therefore, each interval  $n$  is represented by the sum of all the streams' enthalpies contributing at the specific interval  $q_{p,m,n}$  ( $\forall p \in P, \forall m \in groups, \forall n \in N - 1$  hot streams enthalpies are considered to be positive while those of cold streams are negative) that determine whether the interval has a surplus of heat or is in deficit depending on the sum's sign, thereby the resulting heat cascade and GCC areas can be exploited in order to analyze the possibilities for heat exchange with the network.

At first, to be able to study the different opportunities of installation of heat recovery networks on the temperature scale while satisfying the heating and cooling requirement of all streams of each process, an energy balance at each temperature interval of the scale is written for the components interacting at the defined interval: heat excess or requirement  $q_{p,m,n}$ , heat supplied ( $qpn_{p,m,n,net}$  for liquid intermediate networks or  $qps_{p,m,n}$  for steam networks) or received ( $qnp_{p,m,n,net}$  liquid intermediate networks or  $qsp_{p,m,n}$  for steam networks) from the network, the energy that remains is cascaded to lower temperatures, usually called the remainder, and is represented by  $r_{p,m,n}$  (equation 10). In each period for every plant, at the highest interval, hot local utility  $qs_{p,m}$  can be added to complement the heat demand (equation 9) and it is associated to each process independently to the network, also a cold utility  $qw_{p,m}$  at the lowest intervals can be included to close the energy balance and fulfil the cooling demands (equation 11). The cold utilities used to cool down the process can be an ambient source (e.g. air cooler or cooling water) or a refrigeration system when the stream to be cooled is colder than the ambience. Figure 4 shows the heat balance at the intervals of the discrete temperature scale.

For  $n = 0$

$$qs_{p,m} + r_{p,m,n} = q_{p,m,n} + qpn_{p,m,n,net} - qnp_{p,m,n,net} + qps_{p,m,n} \quad (9)$$

For  $n \in N - 1 / n \neq 0$  and  $n \neq N - 1$  :

$$r_{p,m,n} - r_{p,m,n-1} = q_{p,m,n} + qpn_{p,m,n,net} - qnp_{p,m,n,net} - qsp_{p,m,n-1} + qps_{p,m,n} \quad (10)$$

For  $n = N - 1$

$$-r_{p,m,n-1} = q_{p,m,n} + qpn_{p,m,n,net} - qnp_{p,m,n,net} - qsp_{p,m,n-1} + qps_{p,m,n} + qw_{p,m} \quad (11)$$

These equations are valid for  $\forall p \in P$  and  $m \in groups$

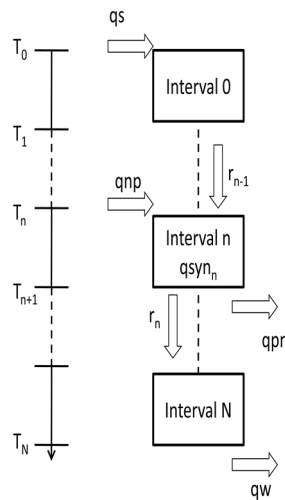

Figure 4: Energy balance at each interval

## 2.2 Heat exchange via network



The site wide heat integration performed between different processes is considered to be indirect via intermediate heat recovery networks that can be liquid or steam. In what follows, we present how to model these networks.

### 2.2.1 Liquid networks

The tertiary network installed between the plants to ensure the energy transfer does not store energy. Thus the sum of the heat supplied from all plants to the network is equal to the sum of heat transferred from the network to all plants in each period.

$$\sum_{m \in \text{groups}, n \in N-1} qpn_{p,m,n,net} = \sum_{m \in \text{groups}, n \in N-1} qnp_{p,m,n,net} \quad \forall p \in P, \forall net \in \text{networks} \quad (12)$$

All potential combination of networks within the defined research domain are examined by the solver, accordingly, the results will consist in a large number of networks with small capacities which is not realistic. To limit the number of networks, binary variables are introduced that will indicate their existence.

$$\sum_{m \in \text{groups}, n \in N-1} qpn_{p,m,n,net} - Qmax * \text{binarynetworks}_{p,net} \leq 0 \quad (13)$$

$\forall p \in P, \forall net \in \text{networks}$

where  $Qmax$  is a very high value, or the maximum heat transfer rate that a network is not allowed to exceed. We can observe that when  $qpn$  is not null (it means that there exists a network), then  $\text{binarynetworks}$  must be equal to 1.

The sum of all binary variables must be less than a maximum number of allowed networks to be installed fixed by the user  $Nbresmax$ ;

$$\sum_{net \in \text{networks}} \text{binarynetworks}_{p,net} \leq Nbresmax, \forall p \in P \quad (14)$$

In addition, the number of networks chosen by the model to be installed is the same in all periods and the can be done using the following equation:

$$\sum_{net \in \text{networks}} \text{binarynetworks}_{p,net} \leq \sum_{net \in \text{networks}} \text{binarynetworks}_{p+1,net}, \forall p \in P - 1 \quad (15)$$

With these additional constraints, only interesting installations will be defined while unlikely configurations are eliminated.

### 2.2.2 Steam networks

For a shared steam network, unlike the liquid recovery network, a potential centralized steam site utility  $qsteamutility_{p,n}$  is considered and may be used in order to provide the additional heat needed at each interval. The total heat needed to be delivered to the processes represents the capacity of the network of specific temperature  $qnetwork$  (equation 16)

$$\sum_{m \in \text{groups}} qsp_{p,m,n} = qnetwork_{p,n}, \forall p \in P, n \in N - 1 \quad (16)$$

The following equation (17) ensures that the heat delivered from a network is either supplied from the centralized utility or recovered from other processes.

$$q_{network_{p,n}} = q_{steamutility_{p,n}} + \sum_{m \in groups} q_{sp_{p,m,n}}, \forall p \in P, n \in N - 1 \quad (17)$$

Binary variable is also introduced to limit the number of steam networks and the capacity at each temperature interval using equation (18), (19) and (20).

$$q_{network_{p,n}} - Q_{max} * binarynetworks_{p,n} \leq 0, \forall p \in P, n \in N - 1 \quad (18)$$

$$\sum_{net \in N-1} binarynetworks_{p,n} \leq Nbresmax, \forall p \in P \quad (19)$$

$$\sum_{net \in N-1} binarynetworks_{p,n} \leq \sum_{net \in N-1} binarynetworks_{p+1,n}, \forall p \in P - 1 \quad (20)$$

## 2.3 Economic cost of utilities

At first, the costs involved in heat transport network are divided between operating costs that are cumulated over a time period and capital or investment costs. In other words, investment costs and operating cost are expressed in different time scale. Thus, in order to present all costs on the same scale, an actualisation factor is multiplied to the operating cost.

$$actu = \sum_{y=1}^{integration\ period} (1 + taux)^{-y} \quad (21)$$

where  $taux$  is the interest rate.

The operational cost of utilities used to satisfy the heating demand is one component of the objective function to be minimized and it is calculated using equation 22 where  $NbOpHours$  is the number of operating hours per year and  $lp_p$  is the ratio of the duration of the period  $p$  to the sum of the duration of all periods

$$\begin{aligned} costutilities = & \sum_{p \in P, m \in groups} q_{sm} * costutility * actu * NbOpHours * lp_p \\ & + \sum_{p \in P, m \in groups, n \in N-1} q_{steamutility_{p,n}} * coststeamutility_n * actu \\ & * NbOpHours * lp_p \end{aligned} \quad (22)$$

The  $coststeamutility_n$  can vary according to the temperature of the steam and is calculated using this equation:  $coststeamutility_n = \frac{0.2}{1500} * T_n - 0.01, \forall n \in N - 1$

## 2.4 Heat exchangers modelling and cost

### 2.4.1 Heat exchangers modelling

Each hot and cold stream (o) of all processes can be part of the heat exchange with the networks; the heat exchanged with each network could take place on the intervals of the temperature scale of each individual stream (o) that respect the thermodynamic criteria of positive temperature difference with the network temperature. The sum of the potential heat exchange in all the streams belonging to the same plant (represented in equation 23 and 24 using  $qpne$  and  $qnpe$  to characterize the exchange between a specific stream o at specific intervals) with a network net should be equal to the heat exchange between a network and a plant

$$\forall p \in P, m \in groups, n \in N - 1, net \in networks$$

$$\sum_{nn \in N-1, ns \in N-1, o \in \text{streams}_m, i \in I} qpne_{p,m,n,net,ns,nn,o,i} = qpn_{p,m,n,net}, \quad (23)$$

$$\sum_{nn \in N-1, ns \in N-1, o \in \text{streams}_m, i \in I} qnpe_{p,m,n,net,ns,nn,o,i} = qnp_{p,m,n,net}, \quad (24)$$

where  $ns$  and  $nn$  are the temperature's indices to determine the interval at which the stream exchanges heat as shown in figure 5.

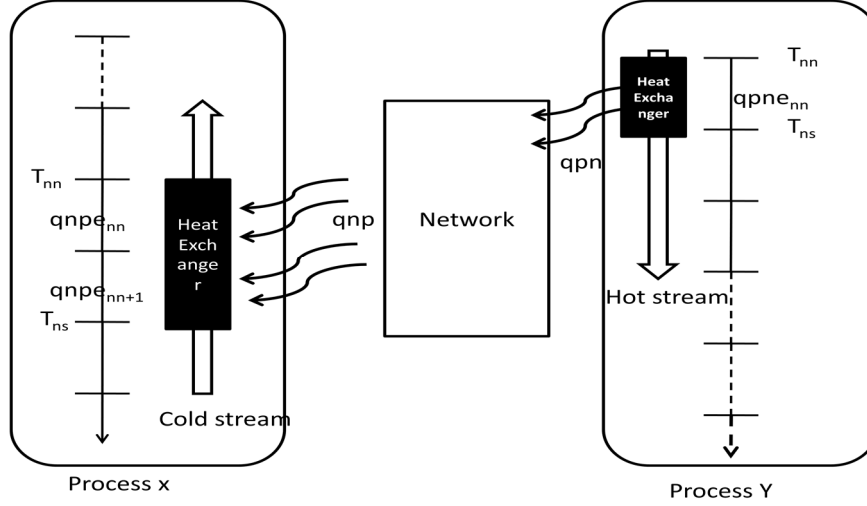

Figure 5: heat exchanger superstructure

It should be noticed that an additional index  $i$  is added to the variable  $qpne$  and  $qnpe$  which will be used in the calculation of the cost of the heat exchanger and explained in section 2.4.2.

In another hand, equation 25 guarantees that the heat exchanged by a specific hot stream with the networks between two intervals is less than or equal to the heat surplus presented by this specific stream within these intervals. In fact, the contribution of a stream  $o$  that belong to a process  $m$  at each interval  $n$  ( $qo_{p,m,n,o}$ ) is pre calculated and is used in the equation 25 and 26. Similarly, the capacity supplied to a cold stream between two intervals is less than or equal to the heat deficit within these intervals (equation 26).

$$qpne_{p,m,n,net,ns,nn,o,i} \leq \sum_{d=nn}^{ns} qo_{p,m,d,o}, \quad (25)$$

$$\forall p \in P, m \in \text{groups}, n \in N-1, net \in \text{networks}, nn \in N-1, ns \in N-1, o \in \text{hotstreams}_m, i \in I$$

$$qnpe_{p,m,n,net,ns,nn,o,i} \leq - \sum_{d=nn}^{ns} qo_{p,m,d,o}, \quad (26)$$

$$\forall p \in P, m \in \text{groups}, n \in N-1, net \in \text{networks}, nn \in N-1, ns \in N-1, o \in \text{coldstreams}_m, i \in I$$

The following constraints (27, 28) ensure that heat will be supplied only to the streams' intervals above the pinch point; equally heat is withdrawn from streams' intervals below the pinch point of each process.

$$qpne_{p,m,n,net,ns,nn,o,i} = 0 \quad \text{when } ns > \text{pinch} + 1, \quad (27)$$

$$\forall p \in P, m \in \text{groups}, n \in N-1, net \in \text{networks}, nn \in N-1, ns \in N-1, o \in \text{hotstreams}_m, i \in I$$

$$qnpe_{p,m,n,net,ns,nn,o,i} = 0 \quad \text{when } nn < \text{pinch}, \quad (28)$$

$$\forall p \in P, m \in \text{groups}, n \in N-1, net \in \text{networks}, nn \in N-1, ns \in N-1, o \in \text{coldstreams}_m, i \in I$$

where  $pinch$  represents the temperature interval index of the pinch point

Then the heat exchanger area  $Apne$  that delivers heat to the networks or  $Anpe$  that receives heat from the network from a defined stream between two specific intervals is calculated using the pre calculated  $lmtd$  and  $U$  the overall heat transfer coefficient, fixed by user.

$$Apne_{p,m,n,net,ns,nn,o,i} = \frac{qpne_{p,m,n,net,ns,nn,o,i}}{U * lmtd_{p,m,res,ns,nn}}, \quad (29)$$

$$\forall p \in P, m \in groups, n \in N - 1, net \in networks, nn \in N - 1, ns \in N - 1, o \in hotstreams_m, i \in I$$

$$Anpe_{p,m,n,net,ns,nn,o,i} = \frac{qnpe_{p,m,n,net,ns,nn,o,i}}{U * lmtd_{p,m,res,ns,nn}}, \quad (30)$$

$$\forall p \in P, m \in groups, n \in N - 1, net \in networks, nn \in N - 1, ns \in N - 1, o \in coldstreams_m, i \in I$$

The formulation lead to a large number of possible temperature couples for all streams that can be included, especially if its number is high. However, the additional  $\Delta T_{net}$  required between the streams' and intermediate network to have realistic heat exchangers shifts the temperature of hot streams downwards and cold streams temperature upwards which will reduce the range of possible heat exchange. Another way to decrease the computational time is by prioritizing combination with higher driving force that eventually need lesser area to accomplish the heat exchange. It is used when only one network is implemented for the heat recovery, thus to attain a high temperature difference for example between a hot stream and a network, the highest interval for hot streams within the allowed domain is kept mainly. Eventually binary variables can be added to specify the number of heat exchangers that can be installed.

#### 2.4.2 Heat exchangers cost function

The investment cost of heat exchangers that is part of the CAPEX (capital expenses) is included in the objective function to minimize. In fact, mainly the cost of heat exchanger depends on its material and the type of the exchanger. The cost of a single heat exchanger with surface area  $A$  can be calculated using the following simple non linear equation 31

$$Costexchangers = a + b * A^c \quad (31)$$

where a,b,c are parameters that vary according to the material and technology. However to keep the linearity of the model, a piecewise linearized cost function is used and its general form:

$$Costexchangers = F_i + V_i * A \quad for \ A \in (A_i, A_{i+1}) \quad (32)$$

where  $F_i$  and  $V_i$  are parameters; and the index  $i$  represents the surface's interval to which the exchanger belongs to. The parameters  $F$  and  $V$  can be calculated via the spline interpolation technique over the original non linear relation. Binary variables are added to identify a unique interval to which each calculated heat exchanger area belongs (equations (33-38)) where the sum of all binary variables for all intervals  $i$  is less or equal to one.

For hot streams:  $\forall p \in P, m \in groups, n \in N - 1, net \in networks, nn \in N - 1, ns \in N - 1, o \in hotstreams_m, i \in I$

$$Apne_{p,m,n,net,ns,nn,o,i} \leq A_i * binaryexchangerpn_{p,m,n,net,ns,nn,o,i}, \quad (33)$$

$$Apne_{p,m,n,net,ns,nn,o,i} \geq A_{i+1} * binaryexchangerpn_{p,m,n,net,ns,nn,o,i}, \quad (34)$$

$$\sum_i binaryexchangerpn_{p,m,n,net,ns,nn,o,i} \leq 1 \quad (35)$$

For Cold streams:  $\forall p \in P, m \in groups, n \in N - 1, net \in networks, nn \in N - 1, ns \in N - 1, o \in coldstreams_m, i \in I$

$$Anpe_{p,m,n,net,ns,nn,o,i} \leq A_i * binaryexchanger_{p,m,n,net,ns,nn,o,i} \quad (36)$$

$$Anpe_{p,m,n,net,ns,nn,o,i} \geq A_{i+1} * binaryexchanger_{p,m,n,net,ns,nn,o,i} \quad (37)$$

$$\sum_i binaryexchanger_{p,m,n,net,ns,nn,o,i} \leq 1 \quad (38)$$

Figure 6 represents the discretized intervals for the surface of the heat exchanger and its corresponding coefficients for the calculation of the cost.

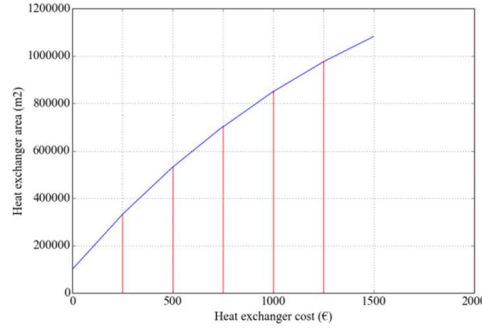

**Figure 6: heat exchanger surface cost linearized function**

On the other hand, the binary variables are multiplied to the fixed cost in order to prevent adding cost to the objective function and the final heat exchangers cost function written in the model is represented in equation 39.

$$\begin{aligned}
 & costexchangers \\
 & = \left(\frac{1}{P}\right) \\
 & * \left( \sum_{p \in P, m \in groups, net \in networks, nn \in N-1, ns \in N-1, o \in streams_m, i \in I} (Apne_{p,m,n,net,ns,o,i} * V_i \right. \\
 & + binaryexchanger_{p,m,n,c,d,ns,nn,o,i} * F_i) \\
 & + \sum_{p \in P, m \in groups, net \in networks, nn \in N-1, ns \in N-1, o \in streams_m, i \in I} (Anpe_{p,m,n,net,ns,o,i} * V_i \\
 & + binaryexchanger_{p,m,n,c,d,ns,nn,o,i} * F_i))
 \end{aligned} \quad (39)$$

The equations described in this section correspond to the case with liquid heat recovery network. Yet a similar set of equations is written to model the heat exchange between the hot and cold process streams with the steam networks, to specify the heat exchangers superstructure and to estimate its costs.

## 2.5 Hydraulic Modeling

The indirect heat exchange between different plants requires piping networks. The model considers the available paths and the restriction flow on routes defined by the designer, determines the best pipe routing depending on the distances between plants within the eco-park and sizes the pipes needed in order to select an optimal heat recovery network operating over all the considered periods. The hydraulic equations include: heat balance at nodes, pressure equilibrium, calculation of velocity in pipes and its diameter.

### 2.5.1 Heat balance at nodes

As mentioned before, the geographical positioning of the plants and the potential pipe routing allows the determination of junctions and nodes where heat flows through the network. The connection between the nodes represents a piping path and is defined by two nodes. Equation 40 insures that at each node the energy balance is respected (no heat storage is considered): the sum of all the flows entering a node  $n$  should be equal to those leaving it; since each plant is modeled as a node heat supplied to a plant or withdrawn from the plant at a node  $n$  will be transferred to other nodes through the paths ( $qch_{path}$ ) connected to that node. Figure 7 shows a possible contribution of a plant at a node. In fact  $qch_{path}$  is given a positive sign for paths when the flow is entering the node  $n$  and a negative sign when the flow is leaving the node  $n$  and these conventional directions are predefined as mentioned in paragraph 2.

$$\sum_{paths \in PATHS} qch_{p,path,net} + \sum_{m \in groups, n \in N-1} qpn_{p,m,n,net} - \sum_{m \in groups, n \in N-1} qnp_{p,m,n,net} = 0, \quad (40)$$

$\forall p \in P, net \in networks, node \in NODES$

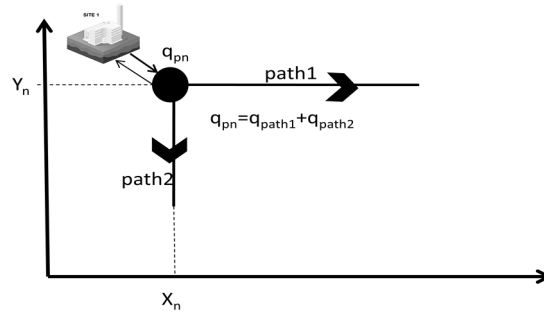

Figure 7: Example of a plant contribution at a node

## 2.5.2 Velocity and pipe diameter calculation

The sizing of pipes required for the indirect network installation between multiple plants depends on the mass flow rate of the fluid flowing through the defined paths. A larger diameter indicates a higher investment of pipeline. In addition, higher flow rate requires more power for transportation, resulting in a higher pump investment and power cost. Consequently, the dimensions of pipes of each potential installation are calculated and its costs are minimized in the objective function.

Firstly, the mass flow rate is calculated from the heat capacity in paths using equation:

$qch_{path} = \dot{m} * \Delta h$  where  $\Delta h$  is the enthalpy variation during heat transfer.  $\Delta h = c_p * \Delta T$  where  $c_p$  is the specific heat capacity and  $\Delta T$  is the network temperature difference for liquid networks and  $\Delta h$  is the latent heat for networks using steam. Then, the following equation is used to calculate the velocity and the diameter at each path.

$$\frac{qch_{p,path,net}}{\Delta h} = \rho * \sum_{z \in diam, v \in V} (Vp_{p,net,v,z,path} + Vn_{p,net,v,z,path}) * a_z, \quad (41)$$

$\forall p \in P, net \in networks, path \in PATHS$

$\rho$  is the density of the fluid flowing in a pipe characterized by  $a_z$  the cross-sectional area  $a_z = \pi * D_z^2 / 4$ . The model will choose one diameter for each path from a predefined set  $diam$ . In fact, the pipes to be used and installed have fixed diameter sizes  $D$  defined by the user and each diameter is characterized by its linear meter cost; hence the use of the index  $z$  for the diameter. The model chooses a specific couple of diameter/velocity for each pipe. In addition, the velocity obtained is characterized with an index  $v$  that specify an interval the continuous variable velocity. Indeed, this method is required because of the linearization of the pressure drop equation as a function of the velocity. The proper limit of the velocity of fluid flowing in a path is divided on several consecutive intervals  $v$  characterized by an upper  $V1_v$  and lower bound  $V2_v$  values. Likewise  $qch_{p,path,net}$ , the velocity in a

specific path can be positive ( $Vp$ ) or negative ( $Vn$ ), the model choose one velocity variable ( $Vp$  or  $Vn$ ) for each path which will determine the direction of the flow relatively to the one defined by the indexes of the path's nodes. Also, binary variables are used in equation (42, 43, 44, and 45) to determine the velocity interval and in equation 46 to ensure a selection of a unique couple velocity-diameter for each path for a specific period and network.

$\forall p \in P, net \in networks, v \in V, z \in diam, path \in PATHS$

$$Vp_{p,net,v,z,path} \leq V1_v * binaryvp_{p,net,v,z,path} \quad (42)$$

$$Vp_{p,net,v,z,path} \geq V2_v * binaryvp_{p,net,v,z,path} \quad (43)$$

$$Vn_{p,net,v,z,path} \geq -V1_v * binaryvn_{p,net,v,z,path} \quad (44)$$

$$Vn_{p,net,v,z,path} \geq -V2_v * binaryvn_{p,net,v,z,path} \quad (45)$$

The sum of the corresponding binary variables for one path should be equal or less than one and hence the model chooses a specific interval and a single direction in a certain path for each period and network.

$$\sum_{v \in V, z \in diam} binaryvp_{p,net,v,z,path} + \sum_{v \in V, z \in diam} binaryvn_{p,net,v,z,path} \leq 1, \quad (46)$$

$\forall p \in P, net \in networks, path \in PATHS$

Two additional constraints are added for the excluded paths fixed by the user in the input parameters. This constraint sets the velocity binary to zero for all excluded paths.

$$\forall p \in P, net \in networks, z \in diam, v \in V, path \in PATHS / path \text{ is excluded from the study} \\ binaryvp_{p,net,v,z,path} = 0 \quad (47)$$

$$binaryvn_{p,net,v,z,path} = 0 \quad (48)$$

### 2.5.3 Economic cost of piping

The cost of pipes can be calculated using the equation 49 in which all binary variables associated to velocity of all paths are multiplied to path's length  $l$  and the linear cost of the picked diameter.

$$costpipes = \left(\frac{1}{P}\right) * \sum_{p \in P, net \in networks, v \in V, z \in diam, path \in PATHS} l_i \\ * (binaryvp_{p,net,v,z,path} + binaryvn_{p,net,v,z,path}) * price_z \quad (49)$$

### 2.5.4 Pressure drop and pumping power calculation for networks using liquid as heat transfer medium

#### 2.5.4.1 Pressure drop

To complete the hydraulic modeling, pressure drop calculations are added to the model. Pressure drop due to friction loss in a pipe (head loss) is calculated commonly using the non linear equation in 50.

$$H = f * \left(\frac{l * V^2}{D * 2 * g}\right) \quad (50)$$

Where: H head loss, f friction factor, l length, D inner diameter of pipe, V velocity, g gravitational acceleration.

Nevertheless, in this MILP model, pressure drop calculation is linearized in terms of velocity using a piecewise linearization approach so that to get a higher accuracy and the general form in replaced by

equation 51. In fact, the *binaryvp* /*binaryvn* are multiplied to the constant of the linearized function so the pressure drop would set up to 0 when the velocity is null. Also both velocity variables *Vp* and *Vn* are used for each *path* only one of them is non zero.

$$H_{p,net,path} = f * \left(\frac{l}{2 * g}\right) * \sum_{z \text{ in diam}} \frac{1}{D_z} * \sum_{z \in diam, v \in V} (A_v * V_{p,net,v,z,path} + B_v * \text{binaryvp}_{p,net,v,z,path} - A_v * V_{n,net,v,z,i} + B_v * \text{binaryvn}_{p,net,v,z,path}), \forall p \in P, net \in networks, path \in PATHS \quad (51)$$

In fact, linearization consists in finding the continuous linear function using curve fitting and thus the coefficients  $A_v$  and  $B_v$  for each velocity interval.

In addition, in network piping design, pressure drop equilibrium within loops should be considered. A closed loop is several paths of pipes that begins and ends at the same node. The user defines a set of loops *LOOPS* and their corresponding paths. The pressure drop between two nodes in the loop is the same whatever the paths that connect these nodes. When closing the loop, the Kirchhoff law allows to represent this pressure drop equilibrium and this is written in the model using equation 52 where *S* is used for sign convention.

$$\sum_{path \in LOOPS} H_{p,net,path} * S_{loop,path} = 0, \forall p \in P, net \in networks, loop \in LOOPS \quad (52)$$

However some potential paths are not included ( their binary is null) in the piping network which will lead to no flow thus a null pressure drop within a loop which will makes the Kirchhoff law not true. For this reason, each pipe is associated with a potential closed valve and this is interpreted by adding very large pressure losses coefficient *Hs* into the pressure losses equation which will lead to a virtual very small flow passing in such paths with null binaries.

$$H = (Hs + f) * \left(\frac{l}{D}\right) * \left(\frac{V^2}{2 * g}\right) \quad (53)$$

#### 2.5.4.2 Pumping power

The pumping power needed to perform heat transportation can also be calculated, using the pressure drop in pipes and the volumetric flow rate of liquid, the original form of the equation is presented in equation 54.

$$Pumping = f * \left(\frac{l * V^2}{D * 2 * g}\right) * V * A \quad (54)$$

In the model the previous equation is replaced by the linearized form represented in equation 55 to obtain the pumping power needed for each period

$$Pumping_{p,net,path} = f * \left(\frac{l}{D * 2 * g}\right) * A * \sum_{z \in diam, v \in V} (AA_v * V_{p,net,v,z,path} + BB_v * \text{binaryvp}_{p,net,v,z,path} - (AA_v * V_{n,net,v,z,path} - BB_v * \text{binaryvn}_{p,net,v,z,path}), \forall p \in P, net \in networks, path \in PATHS \quad (55)$$



Where  $AA_v$  and  $BB_v$  represent the coefficients of linearization determined using a similar curve fitting approach of the previous paragraph. However, pumping cost is different from that of heat exchangers and pipes because it is part of the operational costs which are cumulated over time and is calculated using equation 56.

$$\begin{aligned} \text{costpumping} = \text{costelecenergy} & \sum_{p \in P, \text{net} \in \text{networks}, \text{path} \in \text{PATHS}} \text{actu} * \text{NbOpHours} * l p_p \\ & * \text{pumping}_{p, \text{net}, \text{path}} \end{aligned} \quad (56)$$

### 2.5.5 Pressure drop calculation for networks using steam as heat transfer medium

For the networks using steam the Unwin formula [29] presented in equation 57 is used to calculate the pressure losses.

$$dp = 0.6753106 * (\rho * V * A)^2 * l * \left( \frac{1 + \frac{91.4}{D}}{\text{rho}} \right) / D^5 \quad (57)$$

$dp$  is the pressure drop in Pa,  $\rho$  is the fluid's density.

Since, the heat recovered or supplied can be affected by the saturation temperature change due to the pressure losses in steam networks the pressure and saturation temperature drop are considered to determine the heat transfer feasibility and the heat exchanger design.

Thereby, at each node, the pressure is calculated using equation

$$dp_{\text{path}} = P_{\text{node1}} - P_{\text{node2}}$$

To calculate the saturation temperature as a function of pressure, the thermodynamic properties of steam are used to create a piecewise linear function  $T_{\text{node}} = f(P_{\text{node}})$ .

### 2.6 Unique investment for heat exchangers and pipes in all periods

Despite periodic variations, an optimal network for heat recovery is chosen and that is feasible in all periods: the heat exchangers areas, the piping routes and their diameters are determined and cannot vary for each period. A set of equations is introduced in the model in order to consider the same exchangers areas to be installed for all periods. The sum of heat exchangers areas installed for a fixed group  $m$  at a specific steam  $o$  have the same values in all periods of operation. These constraints ensure that the topology of the network is the same for all periods, even if its working condition varies.

$$\begin{aligned} \forall p \in P, m \in \text{groups}, o \in \text{hotstreams}_m \\ \sum_{n, \text{nn}, \text{ns} \in N-1, \text{net} \in \text{networks}, i \in I} A p n e_{p, m, n, \text{net}, \text{ns}, \text{nn}, o, i} \\ = \sum_{n, \text{nn}, \text{ns} \in N-1, \text{net} \in \text{networks}, i \in I} A p n e_{p+1, m, n, \text{net}, \text{ns}, \text{nn}, o, i} \end{aligned} \quad (58)$$

$$\begin{aligned} \forall p \in P, m \in \text{groups}, o \in \text{coldstreams}_m \\ \sum_{n, \text{nn}, \text{ns} \in N-1, \text{net} \in \text{networks}, i \in I} A n p e_{p, m, n, \text{net}, \text{ns}, \text{nn}, o, i} \\ = \sum_{n, \text{nn}, \text{ns} \in N-1, \text{net} \in \text{networks}, i \in I} A n p e_{p+1, m, n, \text{net}, \text{ns}, \text{nn}, o, i} \end{aligned} \quad (59)$$

Similarly, the following equations are introduced so that the model chooses the same pipe routing in all periods.

$$\forall p \in P, z \in \text{diam}, \text{path} \in \text{PATHS}$$

$$\sum_{net \in networks, v \in EV} binaryvp_{p,net,v,z,path} = \sum_{net \in networks, v \in EV} binaryvp_{p+1,net,v,z,path} \quad (60)$$

$$\sum_{net \in networks, v \in EV} binaryvn_{p,net,v,z,path} = \sum_{net \in networks, v \in EV} binaryvn_{p+1,net,v,z,path} \quad (61)$$

## 2.7 Objective function

The purpose of this model is to determine a configuration of the heat recovery network operable for all the periods representing the varying operating conditions while minimizing the total cost that includes the heat exchangers to be installed, the networks pipes and the operating costs of the utilities needed to satisfy all process requirements. Total cost includes capital and operating cost expressed on the same time scale.

$$cost = costpumping + costpipes + costexchangers + costutilities \quad (62)$$

## 2.8 Case studies

The developed model described here before is applied to two case studies showing its capability for the design of heat recovery networks with both liquids and steam.

### 2.8.1 Liquid heat recovery network case study

The case study presented in this section involves three industrial processes. The purpose of this case study is, using the described model, to investigate the technical and economical feasibility of the installation of a tertiary heat recovery liquid network that is capable of operating under different operating conditions.

The studied processes are initially described in [23], the geographical positioning of the processes within the site is proposed in figure 8.

	Stream	T <sub>in</sub> (°C)	T <sub>out</sub> (°C)	CP (kW/°C)
Process A	H1	230	55	200
	H2	155	80	733,3
	C1	120	270	-296,8
	C2	70	150	-750
Process B	H1	240	200	800
	H2	230	70	187,5
	H3	150	60	444,4
	C1	50	210	-500
	C2	90	250	-312,5
Process C	H1	250	90	274
	H2	220	80	428,6
	C1	150	260	-390,9

**Table 1: Streams' characteristics at nominal condition**

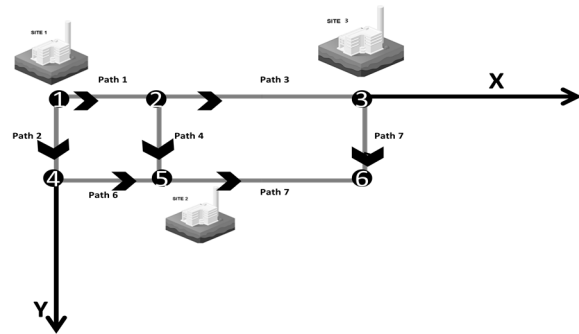

**Figure 8: Geographical positioning of the processes**

In the first step, the optimization was performed with one single period using the nominal parameters of the process streams (table 1). In addition, the maximum number of allowed networks is set to 1, the maximum and minimum allowed temperature of the network are set 170°C and 130°C respectively and the maximum and minimum network temperature difference are set to 30°C and 3°C.

Economically, the operating cost integration period is 100 months and the actualization rate is assumed 0.3% monthly.

	Process A	Process B	Process C
Interaction with network(MW)	2.6	10.5	-13.1
Heat exchanger area installed (HXA)(m <sup>2</sup> )	133.7	373.8	472.9
Local hot utility(MW)	36.3	27.4	15.2

**Table 2: Results for nominal conditions**

One liquid network is selected to recover heat from process C and supply it to process A and B; the hot water network temperatures are 155°C (supply) to 145°C (return). The area of each heat exchanger is determined and the detailed results are summarized in table 2. Hot utility is installed at each process to complement the heating demand.

It should be noticed that for the calculation of costs of pipes included in the objective function the data in table 3 representing the costs pipes according to their sizes and is used for the calculation of the cost of pipes is used.

Diameter (m)	Linear meter cost (€/m)
0.05	430
0.10	519
0.15	420
0.2	519
0.25	699
0.3	827
0.35	983
0.4	1200

**Table 3: Diameter size of pipes and its costs**

In the second step, several variations in the operating conditions of the processes that may usually occur are introduced as periods in order to demonstrate the capability of the model to ensure an optimal design handling multi-period variations.

The variations include:

- An increase in heating demand of process A (increase in mass flow rate of cold stream C2) in second period (cases 1-4).
- Variations in process B (stream C1) are considered: an increase in heating needs (case 5) and a decrease in heat demand (case 6)

For the cases 1 to 4, the heat load variations of stream A-C2 are given in table 4.

Resolving the multi-period MILP, for cases 1 and 2, results in the same network temperatures as in the nominal case and the heat circulated in the network are the same at both periods in both cases. The results are detailed in Table 5 where CP of stream C2 is at nominal condition for the first period and 790 (kW/°C) and 850 (kW/°C) in the second period respectively in cases 1 and 2. Note that the two periods are of equal duration.

	Case 1		Case 2		Case 3		Case 4	
$lp_{p1} = lp_{p2} = 0.5$	P1	P2	P1	P2	P1	P2	P1	P2
Process A: C2 nominal CP=750 (kW/°C)	750	790	750	850	750	1050	750	1200

**Table 4: Description of variations in different cases**

	Case1			Case2		
	Process A	Process B	Process C	Process A	Process B	Process C
Interaction with network(kW)	2.6	10.5	13.1	2.8	10.3	13.1
Heat exchanger area installed(m <sup>2</sup> )	133	370.9	471.8	141.6	365	471.8
Local hot utility(kW) (period1)	36.3	27.4	15.2	36.3	27.4	15.2
Local hot utility(kW) (period2)	36.9	27.4	15.2	39.7	27.4	15.2

**Table 5: Network results for cases 1,2**

The small increase of the mass flow rate of C2 process A (case 1) is compensated by the local hot utility in the corresponding period, however a larger increase of the mass flow rate of the cold stream C2 (case 2) justifies an increase in the surface of the exchanger installed to recover more energy from the process C that is compensated by less heat provided to Process B.

	Case3						Case4					
	Process A		Process B		Process C		Process A		Process B		Process C	
	P1	P2	P1	P2	P1	P2	P1	P2	P1	P2	P1	P2
Q (MW)	5.4	10.2	7.8	9.5	13.1	19.7	6.7	13.4	6.4	7.2	13.1	20.6
A (m <sup>2</sup> )	272.6	272.6	395.8	395.8	858.6	858.6	343.6	343.6	279.1	279.1	858.6	858.6
HU (MW)	36.3	42.9	29.9	30.5	15.2	15.2	36.3	51.5	31.3	30.5	15.2	16.7

**Table 6: Network results for cases 3,4**

The results for a significant increase, in the second period, in mass flow rate of A-C2 (case3: CP = 1050 (kW/°C), Case4: CP=1200(kW/°C)) are presented in table 6. In fact, in these cases, the algorithm determines a larger exchanger for an increased heat recovery and adapts the working temperatures of the network for the first period 155° to 145° whereas for the second period the temperature of the network is 155 °to 135°; since it is a liquid network a large temperature difference in a network allows the use of smaller pipes as it also allows higher energy recovery. Any other heat demand is provided by local boilers.

	Case5			Case6		
	Process A	Process B	Process C	Process A	Process B	Process C
Interaction with network(MW)	0	19.1	19.1	2.6	10.5	13.1
Heat exchanger area installed(m <sup>2</sup> )	0	735.4	735.4	133.6	370.8	471.8
Local hot utility(kW)	38.9	30.5	15.2	36.3	27.4	15.2
	38.9	38.5	15.2	39.7	19.9	15.2

**Table 7: Network results for case 5, 6**

Table 7 shows the results when variations in process B (stream C1) are considered where in case 5 there is an increase in heating needs while in case 6 there is a decrease in heat demand. Indeed, with an increase in heating demand of process B, the model will no longer consider heat supply for process A thus avoiding the cost of the installation of pipes. All the heat will be delivered to process B to cope with the heating demand increase in the second period. In case 6, the resulting configuration is identical to the one obtained in the nominal case.

## 2.8.2 Steam Case Study

The case study presented in this section involves two industrial processes presented in [22] . The purpose of this case study is, using the described model, to minimize the utility consumption by

investigating the heat recovery opportunities across two individual process plants through a steam network and its utility that is capable of operating under different operating conditions. The nominal parameters of streams' characteristics of the processes are presented in table 8. All heat is supplied using recovery network or site utility networks and local hot utilities for each process are not allowed.

	Stream	T <sub>in</sub> (°C)	T <sub>out</sub> (°C)	CP (kW/°C)	ΔT <sub>min</sub>
Process 1	A1	200	100	20	20
	A2	150	60	40	20
	A3	50	120	-70	20
	A4	50	220	-15	20
Process 2	B1	200	50	3	10
	B2	240	100	1,5	10
	B3	200	119	23	10
	B4	30	200	-4	10
	B5	50	250	-2	10

Table 8: Streams' characteristics

The geographical positioning and all available and potential pipe routings of the processes are shown in figure 9 and table 9. Nodes 1 and 5 correspond to the location of processes 1 and 2 respectively. The other nodes represent connection of two or more pipes and could be the location of the network utility.

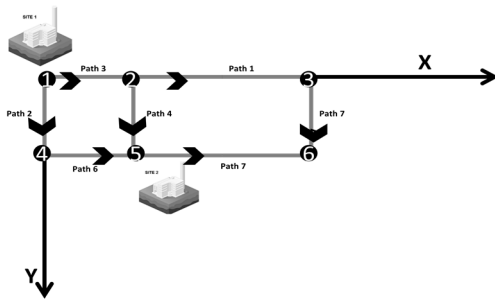

Figure 9 : Geographical positioning of the processes

Nodes	Coordinates	X	Y	Process
1		0	0	A
2		500	0	
3		1500	0	
4		0	-500	
5		500	-500	B
6		1500	-500	

Table 9: geographical coordinates

Three possible scenarios are considered in the case study for the placement of the site central utilities:

- Scenario 1: when all utilities are placed at node 1
- Scenario 2: when all utilities are placed at node 2
- Scenario 3: when all utilities are placed at node 3
- Scenario 4: when all utilities are placed at node 5

In the first step, the optimization was performed with one single period using the nominal parameters of the process streams (table 8). Economically, it is assumed that the operating cost integration period is 150 months and the actualization rate is 0.3% monthly. A maximum number of three steams networks is allowed. The maximum allowable saturation temperature drop in the network is set at 5 ° C. The costs of pipes are calculated according to their sizes using the same date of table 3.

The model is run for the 4 considered scenarios. The same result is obtained for scenario 1 and 3, in terms of network flow capacities, but the piping architecture is evidently not the same. The results for scenario 1 and 3 are shown in table 10 and for scenario 2, 4 in table 11; the tables summarizes the properties of each network and the interaction between the networks and the plants. Figure 10 and 11 represent the GCC of each process where heat received is shown in red while heat withdrawn is shown in blue. The same networks temperatures are found for the 4 scenarios, however the load distribution over the three steam networks varies allowing to optimize the piping needed.

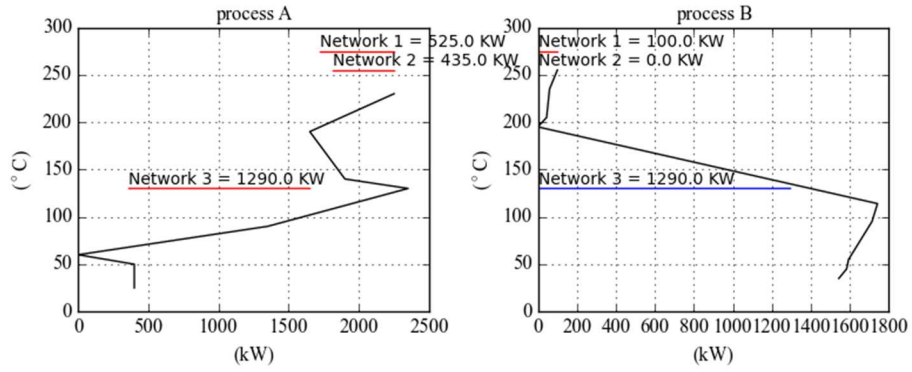

Figure 10 : GCC scenario 1,3

Capacity(kW)	Network 1	Network 2	Network 3
	275°C	255°C	130°C
Process 1	525	435	1290
Process 2	100	0	-1290
Network utility	625	435	0

Table 10 : Results for nominal conditions scenario1,3

Capacity(kW)	Network 1	Network 2	Network 3
	275°C	255°C	130°C
Process 1	0	600	1650
Process 2	100	0	-1290
Utility capacity	100	600	360

Table 11 : Results for nominal conditions scenario2,4

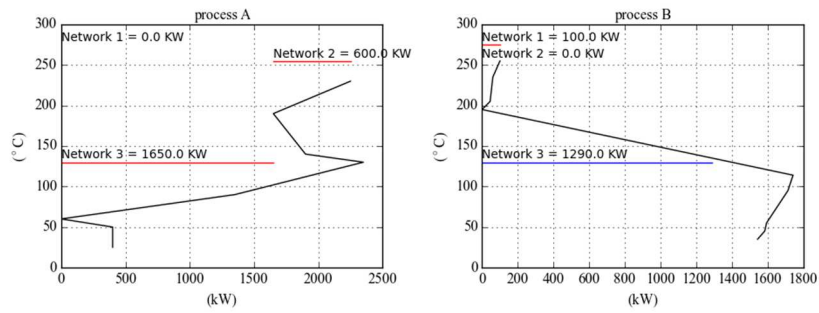
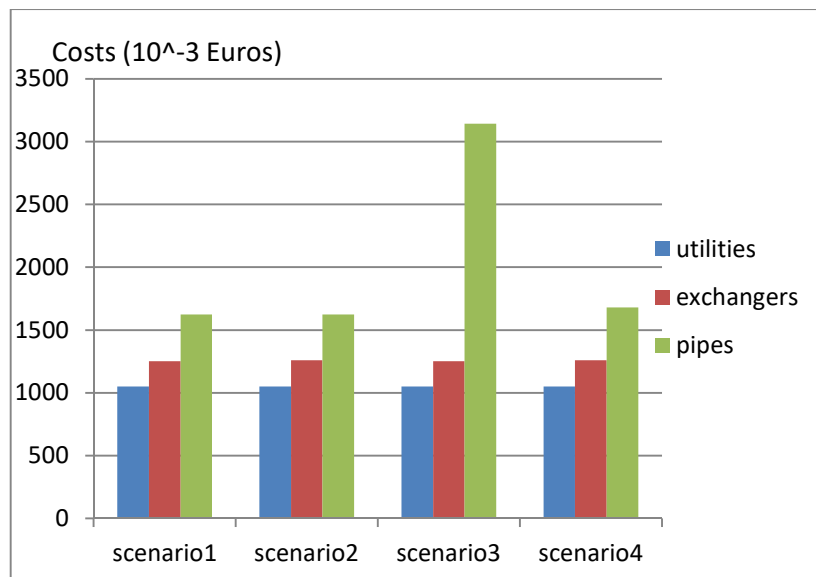

Figure 11 : GCC Scenario2,4

The following graph in figure 12 compares the cost of utilities, heat exchangers and piping needed for each scenario.



**Figure 12: Comparison of cost for the four scenarios**

With nominal operating parameters, for all four cases, the same need for utilities is identified since the heat recovery is the same and a single cost for heat is used (0.03euros/kWh). In scenario 2 and 4, higher costs of heat exchangers is noticed; in fact higher heat capacity (1650 kW) is delivered to process 1 from network 3 (1290 kW for scenario 1 and 3) that is supplied from process 3 and from a site utility thus the need of an additional heat exchanger and thereby a higher cost. For scenario 1 a pipe system is needed to deliver heat from central utility (network 1) at node 1 to node 5. Similarly for scenario 2, equivalent routes are found since the location of the site utility is in the middle between the two processes (piping routes: between node (1, 2) and between (2,5)). In addition the same routing is chosen for the heat recovery of network 3 for both scenarios, thus the same cost of piping is noticed for scenario 1 and 2. On the other hand, in case 3 additional pipes are needed since the location of the site utilities is far from both processes.

**Equal periods duration case**

In a second step, a decrease of 30% of the heat capacity flow rate of process 2 hot stream B2 is considered. Two periods of same duration (same weight) are used; the variations are included in the second period and nominal parameters are used in the first period.

The results show a different temperature of the second network for each period for scenario 1 and scenario 2 (figure 13), the level of the heat supply to processes for the first period is shown in red and in dashed green for the second period. The results are detailed in table 12 and 13. In fact, the amount of heat received by each process varies with the change of the temperature of the network and the temperature ranges of the streams included in the heat exchanger. On the other hand, an optimal choice of site utilities is proposed for each period especially to compensate the decrease of heat recovery from process B for the third network.

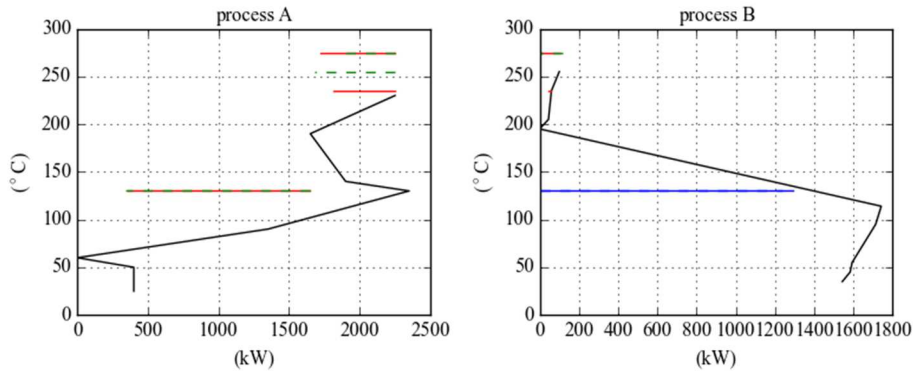

**Figure 13 : GCC scenario 1,2,4**

	Period 1			Period 2		
Capacity	Net 1	Net 2	Net 3	Net 1	Net 2	Net 3
kW	275°C	235°C	130°C	275°C	255°C	130°C
Pro1	525	435	1290	450	468.24	1331.75
Pro2	88.55	11.45	-1290	120	0	-1236.8
Utility	613.55	446.45	0	570	468.24	94.90

**Table 12 : Network’s characteristics and interaction with the processes for scenario 1**

	Period 1			Period 2		
Capacity	Net 1	Net 2	Net 3	Net 1	Net 2	Net 3
kW	275°C	235°C	130°C	275°C	255°C	130°C
Pro1	564.9	322.73	1362.34	600	163.77	1486.22
Pro2	60.1	39.9	-1290	45	75	-1236.8
Utility	625	362.65	72.34	645	238.7	249.37

**Table 13 : Network’s characteristics and interaction with the processes for scenario 2,4**

For scenario 3 (figure 14, table 14), the load is withdrawn from process B in both periods. This load (1260 kW) is slightly lower than the 1290 kW recovered when nominal parameters are used for the simulation due to the decrease of available heat in process B in the second period. Unlike scenario 1

and scenario 2 no utility is added for network 3 because site utilities will be far which will result in higher investment costs for piping and heat exchanger installation (figure 15).

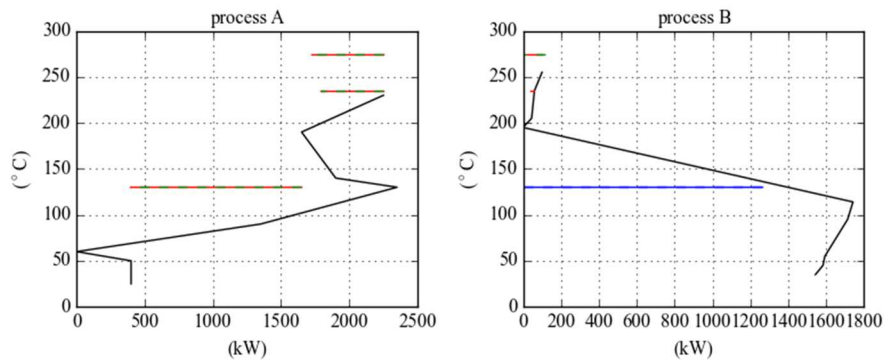

Figure 14 : GCC scenario 3

	Period 1			Period 2		
	Net 1 275°C	Net 2 235°C	Net 3 130°C	Net 1 275°C	Net 2 235°C	Net 3 130°C
Process1	525	465	1260	525	465	1260
Process2	79.12	20.88	-1260	120	0	-1260
Utility capacity	604.12	485.88	0	645	465	0

Table 14 : Network's characteristics and interaction with the processes for scenario 3

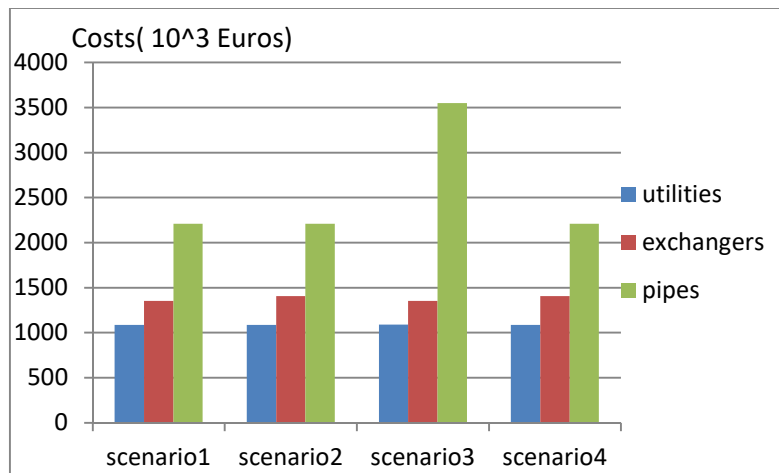

Figure 15: Comparison of cost for the three scenarios

### Unequal periods duration case

In this section, the two periods considered are not of same duration. We consider that the decrease of the heat capacity flow rate of process 2 hot stream B2 occurs only 10% of the time and in the 90% left nominal parameters are involved. For the same four scenarios of placement of central utilities the results are summarized in table 15 and 16 for scenarios 1, 2 and 4 and in table 17 for scenario 3.

	Period 1			Period 2		
	Net 1 275°C	Net 2 235°C	Net 3 130°C	Net 1 275°C	Net 2 255°C	Net 3 130°C
Pro1	525	435	1290	525	384.13	1340.86
Pro2	88.55	11.45	-1290	120	0	-1236.85
Utility capacity	613.55	446.45	0	645	384.13	104.01

Table 15 : Network's characteristics and interaction with the processes for scenario 1

	Period 1			Period 2		
	Net 1 275°C	Net 2 235°C	Net 3 130°C	Net 1 275°C	Net 2 255°C	Net 3 130°C
Pro1	564.9	362.18	1322.88	600	163.77	1486.22
Pro2	60.1	39.9	-1290	45	75	-1236.8
Utility capacity	625	402.11	32.88	645	238.7	249.37

Table 16 : Network's characteristics and interaction with the processes for scenario 2,4



Small differences are noticed between the two cases (equal and unequal periods), variations in the distributions of the heat on the three networks for the four scenarios. Just like the previous case, the temperature of the second network in the second period has changed in order to cope with the variation of the heat supply decrease. Figure 16 compares the operating costs between nominal, two periods of same duration and for the case where variations occur in a small time fraction. Utilities are added in the second period to compensate the inability of the process 2 to supply the same heat as in the nominal case, thus the increase in the operating cost and especially for the case of equal periods.

	Period 1			Period 2		
	Net 1 275°C	Net 2 235°C	Net 3 130°C	Net 1 275°C	Net 2 235°C	Net 3 130°C
Process1	525	465	1260	525	465	1260
Process2	88.54	11.45	-1260	120	0	-1260
Utility capacity	613.54	476.45	0	645	465	0

Tableau 17: Network's characteristics and interaction with the processes for scenario 3

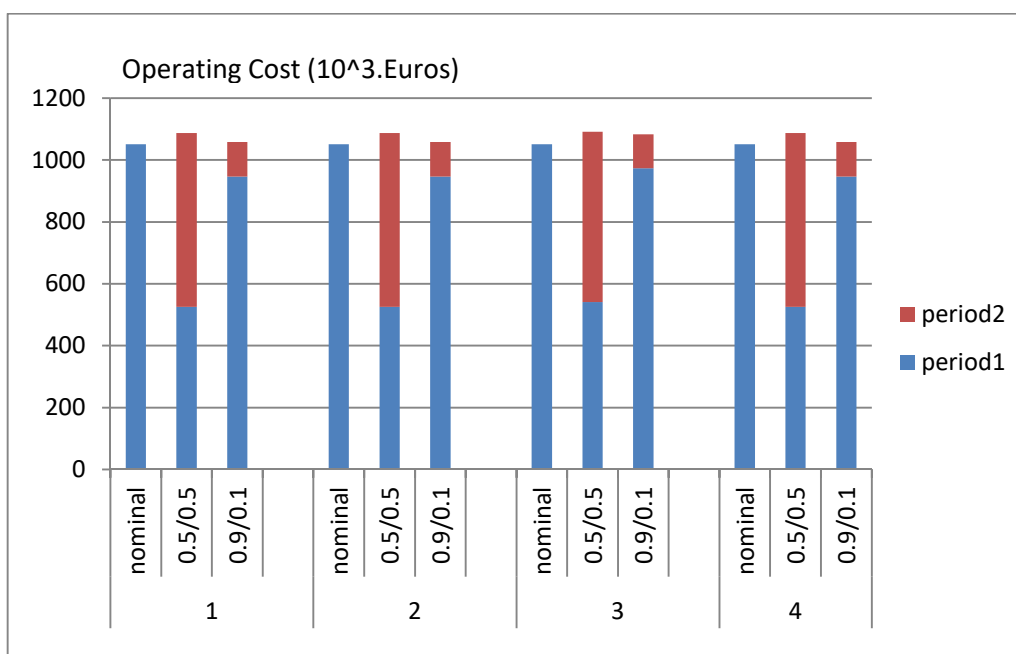

Figure 16 : Comparison of operating cost in nominal and two cases of duration of the variation

Duration of periods	nominal				0.5/0.5				0.9/0.1			
Scenarios	1	2	3	4	1	2	3	4	1	2	3	4
Total cost (10 <sup>3</sup> Euros)	3925	3933	5445	3989	4649	4704	5992	4704	4620	4675	5984	4675

Tableau 18 : Total cost for each case for each scenario

Table18 represent total cost in case of variations for each scenario. It should be noticed that even the variation for a small period of time (10%), implies higher cost compared to the nominal case.

### 3 Conclusions

The present work uses a mathematical optimization approach based on a MILP model for the synthesis of heat exchangers and transport networks between multiple processes; it employs the multi period

approach to include the variations of the operating conditions of the processes in the design procedure. The optimization model searches simultaneously in the integrated period to establish the optimal configuration of the tertiary heat recovery network with best economic and energetic performance that can handle the variability's is obtained with specifications on the type, capacity and temperature of the network as well as the amount of heat transferred between the processes and the network. The resulted heat transport network is able to operate effectively in all the defined periods of operation. Moreover, the model's output provides detailed solution on the selection of heat exchangers areas and their location on process' streams to establish the exchange between process streams and the selected network. Furthermore, the developed model investigates hydraulic and geographical aspects and determines the pumping power needed and piping system to be installed between the plants. The model optimizes an economical objective function composed of network investment costs and utility operation costs. The multi-period model has been demonstrated on two case studies of virtual eco-industrial parks. Processes from literature are used to build the case studies. The case studies compare configurations obtained with nominal parameters and configurations obtained with specific variations in operating conditions; it shows the effect resulted on the choice of network's temperature, on the interaction between the network and the processes, on the dimensions of heat exchangers and pipes and therefore on the costs involved.

### Nomenclature:

*binarynetworks* Binary variable to indicate the presence of a network  
*binaryexchangerpn* , *binaryexchangernp* Binary variable to indicate the presence of a heat exchanger  
*binaryvvp* , *binaryvvn* Binary variable to indicate the presence of a flow in a certain path

CP heat capacity flow rate kW/C  
 $qs$  ,  $qw$  Hot, Cold utility (kW)  
 $\Delta T_{min}$  Minimum temperature difference for internal heat exchange  
 $\Delta T_{net}$  Minimum temperature difference for heat exchange with intermediate network  
CAPEX Investments costs  
 $T_{in}$  Stream inlet temperature  
 $T_{out}$  Stream outlet temperature  
 $Tu_{net}$  Network upper temperature  
 $Tl_{net}$  Network lower temperature  
*lmtd* Logarithmic mean temperature difference (K)  
*l* Length  
*qch* Heat flowing in a certain path  
*q* Sum of streams' enthalpies (heat excess or deficit)  
 $qpn$  ,  $qnp$  Heat delivered, supplied to liquid network (kW)  
 $qps$  ,  $qsp$  Heat delivered, supplied to steam network (kW)  
*r* Remainder heat cascaded to the lower interval  
 $Qmax$  Maximum energy availability  
*Nbresmax* Maximum number of networks  
*qsteamutility* Capacity of site utility  
*qnetwork* Capacity of the network  
*pinch* Pinch location at the temperature scale  
*actu* Actualisation parameter  
*taux* Interest rate  
*costutilities* Cost utilities  
*Costexchangers* Cost of heat exchangers  
*NbOpHours* Number of operating hours

$lp$  Ratio of the duration of the period  
 $qpne$  Heat received by a stream in defined temperature intervals (kW)  
 $qnpe$  Heat supplied by a network to a stream in defined temperature intervals (kW)  
 $qo$  Heat surplus presented by a specific stream within an interval  
 $Anpe, Apne$  Heat exchanger area installed between a cold, hot stream and the network ( $m^2$ )  
 $U$  exchanger heat transfer coefficient ( $kW/m^2.K$ )  
 $F$  Fixed cost for heat exchangers  
 $V$  Variable cost for heat exchangers  
 $A_i$  Lower limit for heat exchanger area at interval  $i$   
 $\rho$  Density of the fluid  
 $a$  Cross-sectional area  
 $Vp, Vn$  Velocity in pipes  
 $V1, V2$  Upper and lower limit of the velocity interval  
 $costpipes$  Cost of pipes  
 $H$  Friction head  
 $g$  Gravitational acceleration  
 $costpumping$  Pumping Cost  
 $A, B$  Coefficients of linearization for pressure drop calculation  
 $AA, BB$  Coefficients of linearization for pumping calculation  
**Subscripts:**  
 $p$  Period  
 $m$  Process  
 $n, mn, ns$  Temperature interval  
 $o$  Stream  
 $path$  Path  
 $net$  Network  
 $node$  Node  
 $z$  Diameter  
 $v$  Velocity

#### 4 References

- [1] S. Papoulias and I. Grossmann, "A structural optimisation approach in process synthesis-2, Heat recovery networks," *Computers and Chemical Engineering*, vol. 7, no. 6, pp. 707-721, 1983.
- [2] A. Ciric and C. Floudas, "Heat exchanger network synthesis without decomposition," *Computers and Chemical Engineering*, vol. 15, no. 6, pp. 385-396, 1991.
- [3] T.F.Yee and I. Grossmann, "Simultaneous optimisation models for heat integration," *Computer and Chemical Engineering*, vol. 14, no. 10, pp. 1165-1184, 1990.
- [4] A. Barbaro and M. J. Bagajewicz, "New rigorous one-step MILP formulation for heat exchanger network synthesis," *Computers and Chemical Engineering*, vol. 29, no. 9, pp. 1945-1976, 2005.
- [5] J. Cerda, M. Galli and M. Isla, "Synthesis of flexible heat exchanger networks—I. Convex networks," *Computers and chemical engineering*, vol. 14, no. 2, pp. 197-211, 1990.
- [6] A. Mian, E. Marteli and F. Maréchal, "Framework for the Multiperiod Sequential Synthesis of Heat Exchanger Networks with Selection, Design, and Scheduling of Multiple Utilities," *Industrial and Engineering Chemistry Research*, vol. 55, no. 1, pp. 168-186, 2016.
- [7] A. Isafiade and D. Fraser, "Interval based MINLP superstructure synthesis of heat exchanger networks for multi-period operations," *Chemical Engineering Research and Design*, vol. 88, no. 10, pp. 1329-1341, 2010.
- [8] D. Jiang and C.-T. Chang, "An algorithmic approach to generate timesharing schemes for multi-period HEN designs," *Chemical Engineering Research and design*, vol. 93, pp. 402-410, 2015.

- [9] A. Isafiade, M. Short and Z. K. Milos Bogataj, "Integrating renewables into multi-period heat exchanger network synthesis considering economics and environmental impact," *Computers and Chemical Engineering*, vol. 99, pp. 51-65, 2017.
- [10] L. Kong, V. Avadiappan, K. Huang and C. Maravelias, "Simultaneous chemical process synthesis and heat integration with unclassified hot/cold process streams," *Computers and Chemical Engineering*, vol. 101, pp. 210-225, 2017.
- [11] V. Dhole and B. Linnhoff, "Total site targets for fuel, co-generation emissions, and cooling," *Computers and Chemical Engineering*, vol. 17, pp. S101-S109, 1993.
- [12] P. S. Varbanov, Z. Fodor and J. J. Klemes, "Total Site targeting with process specific minimum temperature difference ( $\Delta T_{min}$ )," *Energy*, vol. 44, no. 1, pp. 20-28, 2012.
- [13] H. Roderer and M. Bagajewicz, "Targeting procedures for energy savings by heat integration across plants," *AIChE Journal*, vol. 45, pp. 1721-1742, 1999.
- [14] R. Hackl, E. Anderson and S. Harvey, "Targeting for energy efficiency and improved energy collaboration between different companies using total site analysis(TSA)," *Energy*, vol. 36, no. 8, pp. 4609-4615, 2011.
- [15] K. Matsuda, S. Tanaka, M. Endou and T. Liyoshi, "Energy saving study on a large steel plant by total site based pinch technology," *Applied Thermal Engineering*, vol. 43, pp. 14-19, 2012.
- [16] S. Bandyopadhyay, J. Varghese and V. Bansal, "Targeting for cogeneration potential through total site integration," *Applied Thermal Engineering*, vol. 30, no. 1, pp. 6-14, 2010.
- [17] S. Perry, J. Klemes and I. Bulatov, "Integrating waste and renewable energy to reduce the carbon footprint of locally integrated energy sectors," *Energy*, vol. 33, pp. 1489-1497, 2008.
- [18] P. S. Varbanov and J. J. Klemes, "Integration and management of renewables into Total Sites with variable supply and demand," *Computers and Chemical Engineering*, vol. 35, pp. 1815-1826, 2011.
- [19] P. Y. Liew, W. L. Theo, S. R. W. Alwin, J. S. Lim, Z. A. Manan, J. J. Klemes and P. S. Varbanov, "Total Site Heat Integration planning and design for industrial, urban and renewable systems," *Renewable and Sustainable Energy Reviews*, vol. 68, pp. 964-985, 2017.
- [20] P. Y. Liew, T. G. Walmsley, S. R. W. Alwi, Z. A. Manan, J. J. Klemes and P. S. Varbanov, "Integrating district cooling systems in Locally Integrated Energy Sectors through Total Site Heat Integration," *Applied Energy*, vol. 184, pp. 1350-1363, 2016.
- [21] K. H. Chew, J. J. Klemes, S. R. W. Alwi and Z. A. Manan, "Industrial implementation issues of total site heat integration," *Applied Thermal Engineering*, vol. 61, pp. 17-25, 2013.
- [22] P. Y. Liew, S. R. W. Alwi, P. S. Varbanov, Z. A. Manan and J. J. Klemes, "A numerical technique for total site sensitivity analysis," *Applied Thermal Engineering*, vol. 40, pp. 397-408, 2011.
- [23] K. H. Chew, J. J. Klemes, S. R. W. Alwi and Z. A. Manan, "Process modifications to maximise energy savings in total site heat integration," *Applied Thermal Engineering*, vol. 78, pp. 731-739, 2014.
- [24] K. H. Chew, J. J. Klemes, S. R. W. Alwi and Z. A. Manan, "Process modification of Total Site Heat integration profile for capital cost reduction," *Applied Thermal Engineering*, vol. 89, pp. 1023-1032, 2015.
- [25] A. Tarighaleslami, T. Walmsley, M. Atkins, M. Walmsley, P. Y. Liew and J. Neale, "A Unified Total Site Heat Integration targeting method for isothermal and non-isothermal utilities," *Energy*, vol. 119, pp. 10-25, 2017.
- [26] C. Chang, X. Chen, Y. Wang and X. Feng, "An efficient optimization algorithm for waste Heat Integration using a heat recovery loop between two plants," *Applied Thermal Engineering*, vol. 105, pp. 799-806, 2016.
- [27] A. Farhat, A. Zoughaib and K. E. Khoury, "A new methodology combining total site analysis with exergy analysis," *Computers and Chemical Engineering*, pp. 216-227, 2015.

- [28] A. Farhat, A. Zoughaib et K. El Houry, «Heating and cooling networks design algorithm for site wide energy integration,» Pau- France, 2015.
- [29] M. Nayar, Piping Handbook, MCGRAW-HILL, 2000.