



**HAL**  
open science

## On the use of Reed-Solomon codes in Space-Time coding

Massinissa Lalam, Karine Amis Cavalec, Dominique Leroux

### ► To cite this version:

Massinissa Lalam, Karine Amis Cavalec, Dominique Leroux. On the use of Reed-Solomon codes in Space-Time coding. 16th international IEEE International Symposium on Personal, Indoor and Mobile Radio Communications (PIMRC), Sep 2005, Berlin, Germany. <10.1109/PIMRC.2005.1651393>. <hal-02134136>

**HAL Id: hal-02134136**

**<https://hal.science/hal-02134136v1>**

Submitted on 16 Jun 2022

HAL is a multi-disciplinary open access archive for the deposit and dissemination of scientific research documents, whether they are published or not. The documents may come from teaching and research institutions in France or abroad, or from public or private research centers.

L'archive ouverte pluridisciplinaire HAL, est destinée au dépôt et à la diffusion de documents scientifiques de niveau recherche, publiés ou non, émanant des établissements d'enseignement et de recherche français ou étrangers, des laboratoires publics ou privés.



Distributed under a Creative Commons CC BY-NC 4.0 - Attribution - Non-commercial use - International License

# On the use of Reed-Solomon codes in Space-Time Coding

M. LALAM, K. AMIS, D. LEROUX

GET-ENST Bretagne, TAMCIC (UMR 2872 CNRS), SC Department  
Technopole Brest Iroise, CS 83818 - 29238 Brest Cedex 3, FRANCE  
e-mail: massinissa.lalam@enst-bretagne.fr

**Abstract**—In this paper, we present an original use of Reed-Solomon (RS) codes as Space-Time Block Codes (STBCs) and compare them to orthogonal STBCs (OSTBCs). Due to their symbol structure, they can have a representation close to that of an STBC. RS codes are admittedly more complex to decode as they have no orthogonal properties. However, they offer much higher coding rates. In addition, a wide range of these codes can be easily generated. To decode them, we have developed a new algorithm using a sliding encoding-window (SEW), which is combined with the decoding-based Chase algorithm. We compare the RS(15,7) code to the Alamouti one, both having an equivalent coding rate. Its performance compared to Alamouti gets better as the receive diversity increases. Moreover, RS codes do not require the channel to remain constant over the code duration. In fact, they offer better results if the channel changes rapidly, which can be obtained virtually by introducing interleaving.

**Index Terms**—Multiple-Input Multiple-Output (MIMO), Space-Time Block Code (STBC), Reed-Solomon (RS) code, Chase algorithm, Sliding Encoding-Window

## I. INTRODUCTION

In a Multiple-Input Multiple-Output (MIMO) transmission, orthogonal space-time block codes (OSTBCs) [1] are mainly used because of their decoding simplicity thanks to their orthogonal structure. However, their spectral efficiencies are relatively poor compared to transmissions without space-time coding as the number of transmit antennas increases.

To achieve higher spectral efficiency, we propose to use a Reed-Solomon (RS) code [2] as a space-time block code (STBC). By changing the parameters of these codes, we can achieve a wide range of coding rates. Moreover, they offer symbol protection and have a block representation close to that of an STBC. To evaluate their performance, we compare them to the well-known Alamouti scheme [3].

We found a similar approach in [4] for instance, where the decoding algorithm is based on a modified list-based sphere decoder [5]. Martin *et al.* choose an RS code such that one modulation symbol corresponds to one symbol of the code, while we show in this paper that it is more efficient to choose an RS code such that the set of modulation symbols sent by the transmit antennas corresponds to one symbol of the code.

We proposed also a new encoding-based algorithm to decode RS code, which easily produces a list of codewords and can be combined with a decoding-based algorithm such as Chase [6].

This paper is organized as follows. Part II presents OSTBCs and RS codes and focuses on RS-STBC representation simi-

larity. Part III describes the MIMO transmission scheme used, while part IV deals with RS decoding, based on the Chase algorithm combined with encoding techniques. Part V presents simulation results in comparison with the Alamouti scheme and the importance of respecting the RS/STBC configuration to obtain better performance. Part VI concludes this paper by summarizing major results and proposing future work.

## II. SPACE-TIME BLOCK CODE

### A. OSTBC

We denote  $n_t$  the number of transmit antennas and  $n_r$  the number of receive antennas. According to [1] an OSTBC coding  $U$   $M$ -ary modulation symbols  $\mathbf{S} = \{s_k\}_{1 \leq k \leq U}$  must verify:

$$\mathbf{C}\mathbf{C}^H = \sum_{k=1}^U |s_k|^2 \mathbf{I}_{n_t} \quad (1)$$

where  $\mathbf{C} = \{c_{ij}\}_{1 \leq i \leq n_t, 1 \leq j \leq K}$  is an OSTBC built over  $n_t$  transmit antennas, sent during  $K$  modulation symbols of duration  $T_s$  and  $\mathbf{I}_n$  represents the  $n \times n$  identity matrix. Each space-time coded symbol  $c_{ij}$  is a combination of the modulation symbols and their conjugates.

We define the OSTBC coding rate  $R_s$  as the number of useful modulation symbols  $\mathbf{S}$  over the number of space-time coded symbols used in an OSTBC  $\mathbf{C}$ .

$$R_s = \frac{U}{n_t K} \quad (2)$$

We assume a flat fading channel with no attenuation between each transmit antenna and receive antenna and without inter-symbol interference.

We use the same energy to transmit  $U$  useful modulation symbols (average power  $P_s$ ) as  $n_t K$  space-time coded symbols (average power  $P_c$ ). If an error correcting code with a coding rate  $R_c$  is used, then the average signal to noise ratio (SNR) per receive antenna is given by:

$$\begin{aligned} SNR &= \frac{P_r}{P_N} = \frac{n_t P_c}{P_N} = \frac{U P_s}{K P_N} \\ &= bn_t R_s R_c \frac{E_b}{N_0} \end{aligned} \quad (3)$$

where  $P_r$  is the average signal power received per receive antenna,  $P_N$  is the average complex additive white Gaussian

noise (AWGN) power,  $E_b$  is the energy per bit,  $N_0$  is the one-side complex AWGN power spectral density and  $M = 2^b$  is the modulation order.

Applying (2) to typical OSTBCs shows that these codes offer a poor coding rate (e.g.  $R_s = 0.1875$  for  $\mathcal{H}_4$  defined in [1]). To overcome this, we propose to use RS codes as STBCs instead of OSTBCs. Therefore one modulation symbol corresponds to one space-time coded symbol ( $R_s = 1$ ). Only the RS coding rate  $R_c$  is used in the global coding rate transmission.

### B. RS code as STBC

A Reed-Solomon code built over the Galois Field  $\mathcal{GF}(2^m)$  and noted  $RS(n, k)$  is a  $q$ -ary code, where  $q = 2^m = n + 1$ . It has an error correction capability  $t = (n - k)/2$  symbols, each symbol being an element of  $\mathcal{GF}(2^m)$ . One symbol is represented by a unique set of  $\log_2(n + 1) = m$  bits and is called a  $q$ -ary symbol.

We note  $\mathbf{c} = \{c_j\}_{1 \leq j \leq n}$  an RS codeword, where  $c_j = \{c_j^i\}_{1 \leq i \leq m}$  is the  $j^{\text{th}}$   $q$ -ary symbol and  $c_j^i \in \{0, 1\}$ .

$$\mathbf{c} = \begin{pmatrix} c_1^1 & \cdots & c_n^1 \\ \vdots & & \vdots \\ c_1^m & \cdots & c_n^m \end{pmatrix} \quad (4)$$

The  $m \times n$  matrix representation of  $\mathbf{c}$  can be associated with a spatial representation of an RS code if  $m$  bits are transmitted through the  $n_t$  antennas every  $T_s$ . In this case,  $c_j$  is mapped to  $\mathbf{s}_j = \{s_j^i\}_{1 \leq i \leq n_t}$  at time  $jT_s$ . One  $q$ -ary symbol is sent by the  $n_t$  transmit antennas (cf. Fig. 1).

In this configuration, we have:

$$n + 1 = M^{n_t} \Leftrightarrow m = n_t b \quad (5)$$

We call a *super-symbol* the set of  $n_t$   $M$ -ary modulation symbols transmitted during  $T_s$  and denote  $\mathcal{A}_b$  the set of modulation symbols. Assuming (5), there exists a bijection between the set of  $q$ -ary symbols  $\mathcal{GF}(q)$  and the set of super-symbols  $\mathcal{A}_b^{n_t}$ .

A super-symbol being a  $q$ -ary symbol, it will benefit from the RS code protection, which can correct up to  $t$  wrong symbols, whatever the error pattern inside the symbol is (1 to  $m$  wrong bits). Intuitively we think that given a number of transmit antennas and an RS code, one modulation checking (5) should perform well.

## III. TRANSMISSION SCHEME

### A. Transmitter

At the transmitter side, bits are coded with an RS scheme, interleaved by  $\Pi$  (per bit or per  $q$ -ary symbol) and mapped to a Gray scheme over an  $M$ -QAM. Modulation symbols are multiplexed on the transmit antennas to form the vector  $\mathbf{s}_t = \{s_t^i\}_{1 \leq i \leq n_t}$ , sent at time  $tT_s$  as shown in Fig. 1.

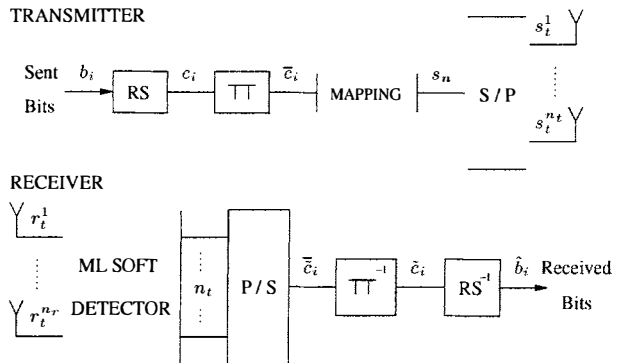

Fig. 1. RS as STBC transmission scheme

### B. Channel

If clock and carrier are perfectly recovered, the MIMO channel is assumed to be an independent Rayleigh block fading channel represented by  $\mathbf{H}_t$ , a  $n_r \times n_t$  matrix at time  $tT_s$ . The channel is constant over  $\tau T_s$  and each path between a transmit antenna and a receive antenna has a unitary average power. The received vector  $\mathbf{r}_t = \{r_t^j\}_{1 \leq j \leq n_r}$  is given by:

$$\mathbf{r}_t = \mathbf{H}_t \mathbf{s}_t + \mathbf{n}_t \quad (6)$$

where  $\mathbf{n}_t = \{n_t^j\}_{1 \leq j \leq n_r}$  is the complex AWGN.

### C. Receiver

Demapping is performed by a near-ML detector providing soft outputs for every coded bit sent (approximated log-likelihood ratios as defined in [7]). After the disinterleaving stage  $\Pi^{-1}$ , these outputs feed an RS decoder.

## IV. RS DECODING ALGORITHM

### A. Chase algorithm

One key point in this transmission system is the RS decoder. We use the second form of the Chase algorithm based on the algebraic Berlekamp-Massey (BM) algorithm [8].

The decoder chooses among the soft inputs  $\tilde{\mathbf{c}}$  the  $n_d$  least reliable independent positions (LRIPs). It decodes the  $2^{n_d}$  test sequences corresponding to all possible patterns for the  $n_d$  values (0 or 1) with an algebraic algorithm, such as the BM.

Decoded word  $\mathbf{c}$  is then stored in  $\mathcal{C}_{n_d}$  only if it is a codeword. The decoder output  $\hat{\mathbf{c}}$  is selected according to:

$$\hat{\mathbf{c}} = \underset{\mathbf{c} \in \mathcal{C}_{n_d}}{\text{argmin}} \|\mathbf{2c} - \mathbf{1} - \tilde{\mathbf{c}}\|^2 \quad (7)$$

where  $\|\cdot\|^2$  is the Euclidean distance.

For an adequate value for  $n_d$  (close to the error correction capability), this algorithm is near-optimal for a binary block code. However, using it for a  $q$ -ary block code such as an RS code requires testing the  $n_d$  least reliable  $q$ -ary symbols, corresponding to  $2^{mn_d}$  decodings. The RS decoder will perform 65536 decodings for  $m = 4$  and  $n_d = 4$ . This process being too computationally expensive, we use the same approximation made in [9] by choosing the  $n_d$  least reliable bits of  $\tilde{\mathbf{c}} = \{c_j^i\}_{1 \leq i \leq m, 1 \leq j \leq n}$  (16 decodings in our example). This choice leads to a sub-optimal algorithm.

### B. The sliding encoding-window algorithm

At high SNR, it appears that all decoded sequences are equal to the same codeword with the Chase-2 algorithm. To increase the codeword diversity, we have developed an algorithm based on encoding techniques: the sliding encoding-window (SEW) algorithm. The SEW algorithm exploits the  $q$ -ary systematic and cyclic properties of an RS code, but processes at the binary level, to quickly generate codewords that are “close” to the received word  $\tilde{\mathbf{c}}$ .

We recall that in systematic coding the information part is visible in the codeword, generally at the beginning or the end of the codeword. With a cyclic  $q$ -ary code, any permutation over  $q$ -ary symbols of a codeword is still a codeword.

Let  $\mathbf{W}$  be a block of  $km$  bits extracted from  $\tilde{\mathbf{c}}$  and  $n_e \leq km$  be the number of the LRIPs inside  $\mathbf{W}$ . By permuting the modulated values ( $\pm 1$ ) at the  $n_e$  LRIPs and encoding the thresholded result, we produce  $2^{n_e}$  codewords which are “close” to the hard decision of  $\tilde{\mathbf{c}}$  (at least  $km - n_e$  bits are identical). These codewords are stored in a set named  $\mathcal{C}_{n_e}$ .

As we use systematic coding, we only introduce codeword diversity over the  $(n - k)m$  bits symbols forming the redundancy part. To have diversity over all bits, we exploit the  $q$ -ary cyclic property of the RS code. We cyclically shift  $\mathbf{W}$  over  $\tilde{\mathbf{c}}$  and compute the same encoding operation until all bits are covered. We call  $\mathbf{W}$  the sliding encoding-window.

Due to systematic coding, the codewords obtained must also be cyclically shifted so that their  $km$ -length information part matches the position of  $\mathbf{W}$  in  $\tilde{\mathbf{c}}$ . We store shifted codewords in  $\mathcal{C}_{n_e}$ .

If the SEW algorithm is used alone, then the decoder output  $\hat{\mathbf{c}}$  verifies the following equation:

$$\hat{\mathbf{c}} = \operatorname{argmin}_{\mathbf{c} \in \mathcal{C}_{n_e}} \|\mathbf{2c} - \mathbf{1} - \tilde{\mathbf{c}}\|^2 \quad (8)$$

We can show that we have  $\lceil \frac{n}{n-k} \rceil$  windows to process, where  $\lceil \cdot \rceil$  is the upper integer part, and that we have introduced at least  $2^{n_e}$  different codewords in  $\mathcal{C}_{n_e}$ .

We note that we keep the same code generator to create the list of candidates, while it has to be re-computed in encoding-based algorithms such as the OSD [10]. Moreover, the whole algorithm can be highly parallelized, as we perform the same process on different inputs derived from the received word.

### C. Chase-2 and SEW combination

In our case, we combine the Chase algorithm with the SEW algorithm to decode the received word  $\tilde{\mathbf{c}}$ . We note  $\mathcal{C}_{n_d, n_e} = \mathcal{C}_{n_d} \cup \mathcal{C}_{n_e}$ . The RS decoder output is now selected according to:

$$\hat{\mathbf{c}} = \operatorname{argmin}_{\mathbf{c} \in \mathcal{C}_{n_d, n_e}} \|\mathbf{c} - \tilde{\mathbf{c}}\|^2 \quad (9)$$

We use two transmit antennas, a QPSK modulation and the systematic RS code  $RS(15, 7)$ . The channel changes every  $T_s$  ( $\tau = 1$ ). The Chase algorithm with  $n_d = 4$  is combined with the SEW algorithm with  $n_e \in \{8, 12, 14, 16\}$ .

We significantly improve the performance as shown in Fig. 2. We have a gain of almost 1.9 dB and 3.4 dB at a BER of  $10^{-3}$  by combining Chase ( $n_d = 4$ ) with SEW ( $n_e = 8$ ) and SEW ( $n_e = 12$ ) respectively. For  $n_e \geq 12$ , we do not significantly improve the decoding efficiency.

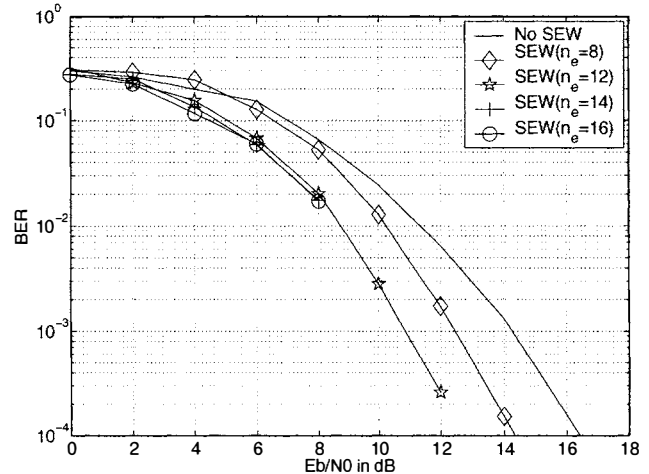

Fig. 2. BER vs  $E_b/N_0$  - QPSK (2Tx, 1Rx) on an independent Rayleigh fading channel ( $\tau = 1$ ) - Influence of the SEW algorithm combined with Chase ( $n_d = 4$ )

As one RS encoding is a less complex operation (using shift registers) than one RS decoding, the use of the SEW algorithm brings codeword diversity and efficiency with a minimum complexity cost.

## V. SIMULATION RESULTS

We use a scheme with two transmit antennas, an  $M$ -QAM modulation and the systematic RS code  $RS(15, 7)$  ( $R_c = 0.4667$ ). The channel changes every  $\tau T_s$ . The RS decoder uses the Chase algorithm with  $n_d = 4$  positions (16 decodings) and the SEW algorithm with  $n_e = 12$  ( $2^{12} = 8192$  encodings) to maintain a reasonable complexity. The Alamouti scheme is also simulated. The global efficiencies are almost the same for the two schemes:  $R_c R_s = 0.4667 * 1 = 0.4667$  for the RS-based STBC and  $R_c R_s = 1 * 0.5 = 0.5$  for the Alamouti STBC. The channel state information is assumed perfectly known at the receiver side. The average signal power received on each receive antenna is unitary ( $P_r = 1$ ).

### A. Importance of the bijection

We use a QPSK and a 16-QAM for the modulation. No interleaving is done between coding and mapping. Results are given in Fig. 3.

In the QPSK case, the  $q$ -ary symbol set and the super-symbol set have the same cardinality ( $\operatorname{card} \mathcal{GF}(16) = \operatorname{card} \mathcal{A}_2^2 = 16$ ). Therefore modulation symbols sent through transmit antennas take advantage of the symbol protection provided by the RS code. The  $RS(15, 7)$  offers better performance than the Alamouti code after  $E_b/N_0 = 9.8$  dB, corresponding to a BER of almost  $5 \cdot 10^{-3}$ .

In the 16-QAM case, the  $q$ -ary symbol has a lower cardinality than the super-symbol set ( $\operatorname{card} \mathcal{GF}(16) < \operatorname{card} \mathcal{A}_4^2 = 256$ ): two  $q$ -ary symbols are sent at a time. The super-symbol protection provided by the RS code does not exist in this case. This lack of protection seems to have a real impact on the performance, since the RS curve is 6 dB away

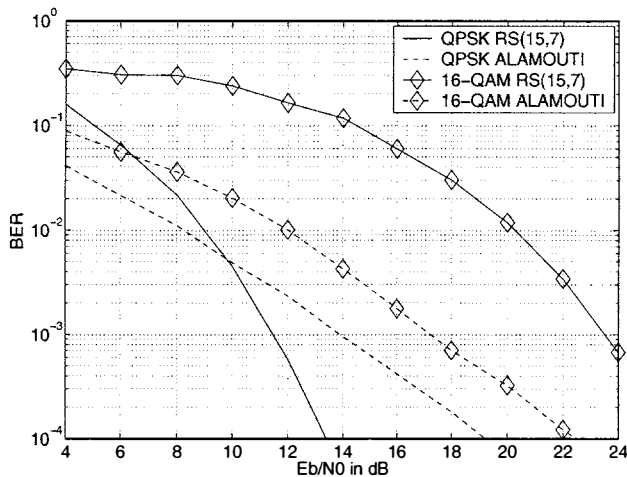

Fig. 3. BER vs  $E_b/N_0$  - QPSK and 16-QAM (2Tx,1Rx) on an independent Rayleigh fading channel ( $\tau = 2$ ) - Influence of the modulation

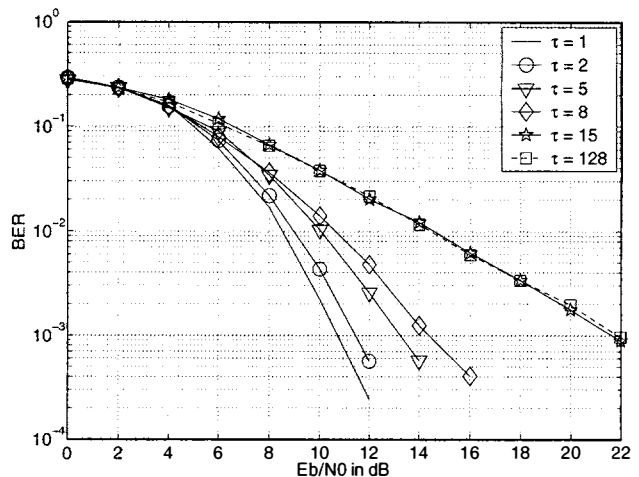

Fig. 4. BER vs  $E_b/N_0$  - QPSK (2Tx,1Rx)  $RS(15,7)$  on an independent Rayleigh fading - Influence of the fading

from Alamouti's for a BER of  $10^{-3}$ . By extrapolation we can estimate that the RS curve intercepts Alamouti's after  $E_b/N_0 = 26$  dB, corresponding to a BER close to  $10^{-5}$ . In this case using this configuration instead of the Alamouti scheme is clearly not a good option.

In a MIMO transmission using a fixed RS code as a STBC and a fixed number of antennas, performance will be better if the modulation verifies (5). In the following, we use two transmit antennas ( $n_t = 2$ ), a QPSK ( $q = 2$ ) and the  $RS(15,7)$  code ( $m = 4$ ) so that (5) holds.

### B. Channel variation

Linear decoding of OSTBCs assumes that the channel remains constant during the code duration  $KT_s$ , while there is no such constraint with RS codes. Moreover the RS performance (Fig. 4) is better in presence of fast Rayleigh fading (small  $\tau$ ), which was a predictable result. The probability that the channel is severe enough to corrupt the  $n$   $q$ -ary symbols of a codeword is lower if the fading is faster. To virtually create a fast fading channel at the receiver side, we can introduce an interleaver after the RS coding. As the curves for  $\tau \geq n$  are identical to the curve obtained for  $\tau = n$ , a square interleaver working on  $q$ -ary symbols must be at least  $n \times n$  for the RS code considered ( $n = 15$ ).

### C. Interleaver

We have an independent Rayleigh fading channel constant over  $8T_s$  ( $\tau = 8$ ) and one receive antenna. The diagonal interleaver  $\Pi$  is either a  $30 \times 30$  bit or a  $15 \times 15$   $q$ -ary symbol interleaver, both working on the same number of bits (900), since  $m = 4$  for  $RS(15,7)$ .

Interleaving increases the BER performance as shown in Fig. 5 with a gain of almost 4 dB for a BER of  $10^{-3}$  for both interleavers. For  $E_b/N_0$  lower than 8 dB, the  $q$ -ary symbol interleaver performs slightly better than the bit interleaver, while afterward they seem to be equivalent.

It appears that bit interleaving at this level of the transmitter is not an interesting option, as it breaks the  $q$ -ary symbol (set

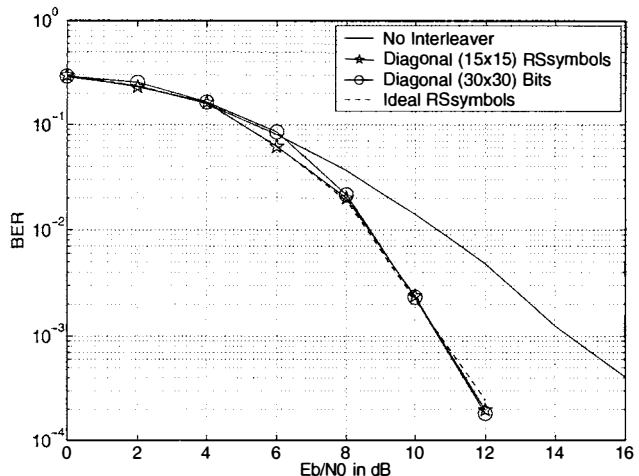

Fig. 5. BER vs  $E_b/N_0$  - QPSK (2Tx,1Rx)  $RS(15,7)$  on an independent Rayleigh fading channel ( $\tau = 8$ ) - Influence of the interleaver

of  $m = 4$  successive bits). Therefore a super-symbol is no longer the direct mapping of a  $q$ -ary symbol even with (5) fulfilled. The diagonal  $q$ -ary symbol interleaver retains the super-symbol protection. Moreover, its curve is the same as the ideal  $q$ -ary symbol interleaver curve for the channel considered ( $\tau = 8$ ).

### D. Receiver diversity

We increase the number of receive antennas from 1 to 4. The BER vs  $E_b/N_0$  is plotted in Fig. 6 with Alamouti performance as a reference. We use the diagonal  $(15 \times 15)$   $q$ -ary symbol interleaver.

Table I gives the SNR after which the RS curve becomes better than the Alamouti one and its corresponding BER for each number of receive antennas.

For RS curves, passing from 1 to 2, from 2 to 3 and from 3 to 4 receive antennas leads to a gain of 8.6 dB, 2.4 dB and 2 dB respectively. Most of the gain is achieved

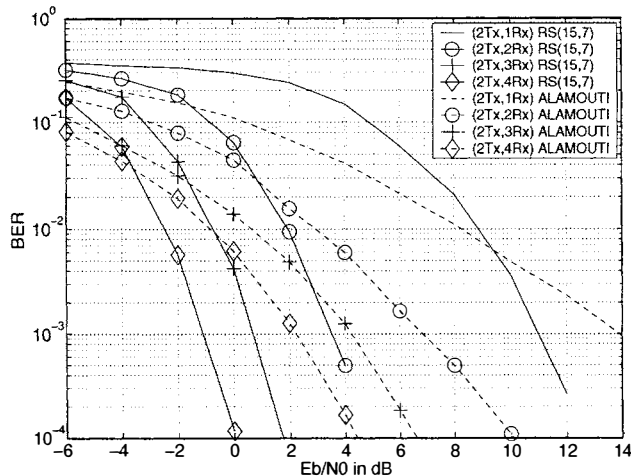

Fig. 6. BER vs  $E_b/N_0$  - QPSK on an independent Rayleigh fading channel ( $\tau = 2$ ) - Receiver diversity

$n_r$	$E_b/N_0$	BER
1	9.4 dB	$6 \cdot 10^{-3}$
2	1.2 dB	$2.8 \cdot 10^{-2}$
3	-1.6 dB	$2.7 \cdot 10^{-2}$
4	-3.6 dB	$3.7 \cdot 10^{-2}$

TABLE I  
RECEIVER DIVERSITY RESULTS

with the introduction of a second receive antenna. Moreover, with more than two receive antennas, the intersection BER remains around  $3 \cdot 10^{-2}$ . We gain only on the SNR threshold by increasing the receive diversity. We note that for the same number of receivers we have a constant gap  $\Delta E_b/N_0 = 3$  dB between the RS and Alamouti curves at a BER of  $10^{-3}$ .

The reception diversity increases the slope of the RS curve, decreasing the SNR threshold from which the RS scheme becomes better than the Alamouti one. However, performance is improved significantly by adding a second receive antenna.

## VI. DISCUSSION

### A. Conclusion

We have highlighted some advantages of using RS codes as STBCs. Although their decoding is more complex than that of OSTBCs, they offer higher coding rates and performance, especially with receiver diversity. We have also introduced a new decoding technique to improve their decoding. The SEW algorithm easily generates a large set of potential codewords by exploiting the cyclic and systematic properties of an RS code.

If the RS code family (which means  $\mathcal{GF}(2^m)$ ), the number of transmit antennas  $n_t$  and the modulation order  $M = 2^b$  hold (5), then we obtain a configuration similar to that of an STBC. The choice of  $k$  will then define the spectral efficiency and the code performance of  $RS(n, k)$ .

Moreover, the decoding rules of an OSTBC assume that the channel remains constant during  $KT_s$ , while there is no such

constraint for an RS code. In fact the lower  $\tau$ , the better the RS performance. With a block fading channel (high  $\tau$ ), a  $q$ -ary symbol interleaver virtually creates faster channel fading (smaller  $\tau$ ) at the receiver side. Therefore it improves the RS performance without breaking the bijection between  $q$ -ary symbols and super-symbols.

### B. Future work

At this moment, many points remain to be investigated. First, we could introduce an error correcting code (convolutional code, block code, etc.) before the space-time code and optimize the interface between these two stages.

We could also increase the number of transmit antennas and choose an adapted RS code if we keep the same modulation. For the modulation symbol detection, we use the near-optimal ML decoder. However, as the modulation order and the number of transmit antennas increase, the complexity grows exponentially. To reduce this complexity, we could use a sub-optimal algorithm such as the sphere decoder and evaluate the resulting performance.

Finally, we could evaluate in greater detail the performance of the SEW algorithm, for instance, the generation of soft outputs: as the SEW algorithm created a large set of candidates, its soft outputs must be more reliable than typical decoding-based algorithms such as the Chase algorithm.

## VII. ACKNOWLEDGMENT

The authors would like to thank the Brittany regional council for the funding of this study. They also wish to thank the reviewers for their comments, which improved the presentation of this paper.

## REFERENCES

- [1] V. Tarokh, H. Jafarkhani, and A.R. Calderbank. Space time block codes from orthogonal designs. *IEEE Trans. on Inform. Theory*, 45(5):1456–1467, July 1999.
- [2] I.S. Reed and G. Solomon. Polynomial codes over certain finite fields. *J. Soc. Ind. Appl. Math.*, 8:300–304, June 1960.
- [3] S. M. Alamouti. A simple transmit diversity technique for wireless communications. *IEEE Journal on Selected Areas on Communications*, pages 1451–1458, October 1998.
- [4] P. A. Martin and D. P. Taylor. High-throughput error correcting space-time block codes. *IEEE Communications Letters*, 8(7):458–460, November 2003.
- [5] B. Hochwald and S. Ten Brink. Achieving near capacity on a multiple-antenna channel. *IEEE Trans. on Communications*, 51(3):389–199, March 2003.
- [6] D. Chase. A class of algorithms for decoding block codes with channel measurement information. *IEEE Trans. Inform. Theory*, 18(1):170–182, January 1972.
- [7] P. Robertson, E. Villebrun, and P. Hoeher. A comparison of optimal and sub-optimal map decoding algorithms operating in the log domain. *IEEE International Conference on Communications*, 2:1009–1013, June 1995.
- [8] E.R. Berlekamp. *Algebraic Coding Theory*. Mc Graw Hill, 1968.
- [9] O. Aitsab and R. Pyndiah. Performance of reed-solomon block turbo code. *Global Telecommunications Conference*, 1:121–125, November 1996.
- [10] M.P.C. Fossorier and Shu Lin. Soft-decision decoding of linear block codes based on ordered statistics. *IEEE Trans. on Inform. Theory*, 41(5):1379–1396, September 1995.