



HAL
open science

Oxyfuel combustion and reactants preheating to enhance turbulent flame stabilization of low calorific blast furnace gas

Abou Bâ, Armelle Cessou, Niomar Marcano, Faustine Panier, Rémi Tsiava, Guillaume Cassarino, Ludovic Ferrand, David Honoré

► To cite this version:

Abou Bâ, Armelle Cessou, Niomar Marcano, Faustine Panier, Rémi Tsiava, et al.. Oxyfuel combustion and reactants preheating to enhance turbulent flame stabilization of low calorific blast furnace gas. *Fuel*, 2019, 242, pp.211-221. 10.1016/j.fuel.2019.01.023 . hal-02126811

HAL Id: hal-02126811

<https://hal.science/hal-02126811v1>

Submitted on 23 Dec 2020

HAL is a multi-disciplinary open access archive for the deposit and dissemination of scientific research documents, whether they are published or not. The documents may come from teaching and research institutions in France or abroad, or from public or private research centers.

L'archive ouverte pluridisciplinaire **HAL**, est destinée au dépôt et à la diffusion de documents scientifiques de niveau recherche, publiés ou non, émanant des établissements d'enseignement et de recherche français ou étrangers, des laboratoires publics ou privés.

Oxyfuel combustion and reactants preheating to enhance turbulent flame stabilization of low calorific blast furnace gas

Abou BÂ¹, Armelle CESSOU¹, Niomar MARCANO², Faustine PANIER², Rémi TSIAVA²,
Guillaume CASSARINO³, Ludovic FERRAND³, David HONORE^{1*}

¹ Normandie Univ, INSA Rouen, UNIROUEN, CNRS, CORIA, 76000 Rouen, France

² Air Liquide CRCD Paris-Saclay, 78354 Les Loges en Josas, France

³ CMI GreenLine Europe, 78280 Guyancourt, France

* Corresponding author

Tel.: +33-232959852

Fax: +33-232959780 .

E-mail address: david.honore@coria.fr

1 **Abstract**

2 The need for the reduction of the environmental impact of combustion systems in terms of pollutant emissions and
3 preservation of non-renewable resources forces to consider the improvement of energy efficiency and to turn
4 towards alternative fuels in industrial combustion furnaces. However, their use may be an issue because of their
5 low calorific value (LCV) compared to traditional natural gas (NG). The present work considers the combination
6 of oxyfuel combustion with fuel and/or oxygen preheating in order to increase thermal efficiency by heat recovery
7 and enhance LCV oxyfuel flame stabilization, without using a supporting fuel as NG. The study is focused on
8 Blast Furnace Gas (BFG) which has one-tenth the heating value of NG.

9 This assessment starts with thermochemical calculations of major flame properties at several reactant temperatures.
10 Two fundamental flame configurations are simulated: a fully premixed 1D flame for the determination of adiabatic
11 temperature, thermal thickness and laminar burning velocity, and a counter-flow diffusion flame for the
12 determination of extinction strain rates. The results show that significant enhancement of oxyfuel flame properties
13 can be obtained thanks to the preheating of BFG and oxygen. The effect of such preheating is then experimentally
14 studied at laboratory-scale (25 kW) using a tri-coaxial burner generating a non-premixed turbulent BFG-O₂ flame.
15 The burner geometry consists of an annular BFG injection surrounded by an inner central oxygen injection and an
16 external annular oxygen injection. Based on a critical Damköhler number, a theoretical analysis of the stabilization
17 limit for a turbulent diffusion BFG-O₂ flame with preheated reactant is described and used as a criterion to calculate
18 the burner dimensions. Detailed flame characteristics are investigated from measurements of flue gas emissions
19 and OH* chemiluminescence imaging. From these, the analysis of flame stability diagrams as function of reactant
20 velocities, thermal power, oxygen distribution and preheating temperatures points out the limits of flame stability
21 and the stable combustion regimes achieved at the different operational conditions. Regarding the emissions, very
22 low levels of pollutant emissions such as CO and NO_x are achieved in most cases. Further analysis of the results
23 shows that transitions between the various types of flames are controlled by a critical convection velocity in the
24 BFG - oxygen mixing layer. This is quantified from the measurements and matches with the theoretical prediction.

25 Complementary large-scale experiments are performed on a semi-industrial facility, with identical burner
26 geometry, scaled-up to 180 kW using the velocity criterion. The flames show similar structures as obtained at
27 laboratory scale, demonstrating the benefit of preheated oxyfuel combustion for the stabilization of LCV flames.
28 These results validate the analysis of the physical phenomena controlling the limit of stability of BFG oxyfuel
29 flames, as well as the burner design strategy of preheated oxyfuel combustion adapted to low calorific fuels, and
30 the scale-up criteria used for this particular case.

31

32 **Keywords:** *oxyfuel combustion ; low calorific fuel ; blast furnace gas ; heat recovery ; preheated combustion ;*
33 *oxygen*

34

35 **1. Introduction**

36 The need for the reduction of the environmental impact of combustion systems in terms of pollutant emissions and
37 preservation of primary resources forces to consider the energy efficiency improvement and to turn towards
38 alternative fuels in industrial combustion furnaces. Defined as possible substitutes to fossil fuels, gaseous
39 alternative fuels comprise several kinds of fuels, such as: syngas issued from biomass, landfill biogas, by-products
40 gas from industrial plants, etc. Despite the large variation of their compositions, one common feature of these
41 alternative fuels is their low calorific value that has a strong impact on flame stabilization and pollutant emissions.
42 The present study is focused on blast furnace gas (BFG) produced in the steel making industry, which has one of
43 the lowest calorific value within the alternative fuel gases, due to the large concentration of inert gases on its
44 composition. The BFG is known to be one of the most difficult by-product fuels to provide stable flame and safe
45 combustion [Komori 2003, Li 2015, Giles 2016]. In practical applications, BFG is usually burn with supported
46 fuel such as natural gas [Gicquel 2003], or coke oven gas [Hou 2011]. Even if using pure oxygen as oxidizer
47 enhances flame stabilization due to the absence of inert nitrogen, oxyfuel combustion of BFG may still require the
48 support of high calorific fuel [Paubel 2007]. From an energetic point of view, air preheating by flue gases heat
49 recovery is a convenient way to increase global thermal efficiency of combustion units, and also to enhance flame
50 stabilization. Such heat recuperative systems have been recently developed to preheat pure oxygen for applications
51 in glass melting furnaces [Joumani 2010]. Moreover, preheating of BFG can be also envisaged to enhance flame
52 stabilization [Moon 2014].

53 In this context, the present work studies the effect of the combination of oxyfuel combustion and reactants
54 preheating for turbulent flame stabilization with low calorific value. The initial step includes thermochemical
55 calculations of oxyfuel BFG flames performed at several reactant initial temperatures to quantify the potential
56 benefit of these parameters. A theoretical analysis of the stability for a BFG-O₂ diffusion flame in the shear layer
57 is used to design a tri-coaxial burner. Following to this, the physical phenomena leading the BFG-O₂ turbulent
58 flame stability are experimentally studied using OH* chemiluminescence imaging and flue gas emissions
59 measurements. Lastly, up-scaling effect is characterized from complementary experiments performed on a semi-
60 industrial facility.

61 **2. Oxyflames properties of several low calorific value (LCV) fuels**

62 Table 1 compares BFG compositions and characteristics to three other alternative fuels: biogas, syngas, coke oven
 63 gas (COG) and methane. BFG is characterized by its high concentration of inert species (N_2 , CO_2), the absence of
 64 methane and a very low H_2 content. It has also very low calorific value corresponding to one-tenth the one of
 65 methane. These characteristics lead to very low laminar burning velocities S_L (Figure 1), as obtained from
 66 simulation of a mono-dimensional stationary and stabilized laminar premixed flame at 298 K and atmospheric
 67 pressure, using the COSILAB[®] software. As no detailed kinetic mechanism has been yet validated in such specific
 68 conditions of oxyfuel combustion of LCV gases with fuel and oxygen preheating, initially, this simulation was
 69 performed using four different mechanisms such as GRI Mech 3.0, Davis, OpenSmoke and Sun mechanisms, with
 70 no major differences between the results [Bâ 2015, Bâ 2017]. The Davis mechanism [Davis 2005], however,
 71 initially developed and validated for CO and H_2 fuel mixtures, has been chosen since it has been validated at the
 72 closest conditions of fuels composition and reactant temperature [Wang 2012].

73 Table 1. Compositions and main properties of typical biogas, syngas, coke even gas (COG)
 74 and blast furnace gas (BFG) compared to methane

	Fuel	Methane	Biogas	Syngas	COG	BFG
Concentrations (% vol.)	CH_4	100	52	7	28	-
	H_2	-	-	9	62	5
	CO	-	-	14	6	23
	CO_2	-	40	20	4	23
	N_2	-	8	50	-	49
Net Calorific Value [kWh/m ³ (n)]		9.94	5.17	1.44	4.75	0.95
Density [kg/m ³]		0.67	1.20	1.18	0.38	1.27
Stoichiometric mixture fraction Z_s [-]		0.34	0.48	0.20	0.24	0.88

75 The laminar burning velocity S_L with the equivalence ratio is presented on Figure 1 for oxyfuel flames of different
 76 fuels such as methane, biogas, syngas, BFG and COG, using the compositions given in Table 1. These are
 77 compared to a CH_4 -air flame, representative of gaseous fossil fuel (natural gas) combustion with air at ambient
 78 temperature as traditional oxidiser. For all these cases, the S_L curve presents the traditional bell shape, but with a
 79 maximum on the lean side for the oxyfuel flames, except for COG- O_2 flame. For the latter, very high values of
 80 laminar burning velocity are reached because of the large concentration of hydrogen in coke oven gas. Such
 81 laminar burning velocity of several meters per second - as for CH_4 - O_2 flame - ensures the strength of these oxyfuel
 82 flames thanks to the use of pure oxygen as oxidiser. As biogas is a 50:50 mixture of methane with CO_2 and N_2
 83 inert gases (Table 1), the laminar burning velocity of biogas oxyfuel flame is still very high. For syngas- O_2 flame,

84 the range of S_L is also sufficiently large to ensure flame stabilization when pure oxygen is used as oxidizer. Oxyfuel
 85 flames of syngas can then be envisaged with or without reactants preheating for industrial applications, despite its
 86 low calorific value. Moreover, operation in the lean conditions can be attractive to reduce NO_x emissions, since
 87 the burning velocity is still large enough for very lean mixtures. Laminar burning velocity is no longer high for
 88 the BFG-O₂ mixture. In this case, S_L is almost constant over the equivalence ratio range calculated [0.4 – 1.3],
 89 showing like for the syngas a possible application to lean combustion. However, the S_L values are too moderate to
 90 guarantee a reliable use in industrial applications, either without reactant heating or having a support with higher
 91 calorific value gases.
 92 These results show that oxyfuel combustion is a convenient technology to guarantee the stabilization of LCV fuels
 93 flames as biogas or syngas. However, additional heat supply might be required for BFG flames.

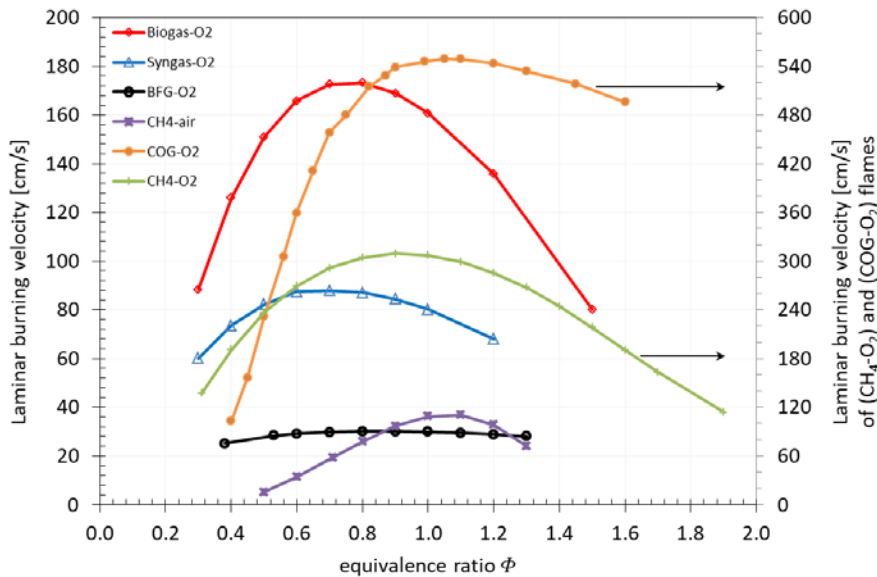

94
 95 Figure 1. Laminar burning velocity S_L vs. equivalence ratio at ambient temperature ($T_{pr} = 300$ K) for different oxyfuel flames and a CH₄-air
 96 flame. (left axis for biogas-O₂, syngas-O₂, BFG-O₂, and CH₄-air flames – right axis for CH₄-O₂, and COG-O₂ flames).

97 **3. Effects of reactants preheating on BFG oxyfuel flame properties**

98 **3.1. Adiabatic temperature and emissions**

99 Figure 2 presents the calculated adiabatic temperature T_{ad} of BFG-O₂ stoichiometric mixture, as well as the major
 100 species molar fractions at equilibrium for several preheating temperatures T_{pr} . The adiabatic flame temperature
 101 increases quasi-linearly with the temperature, from $T_{ad} = 2020$ K at $T_{pr} = 300$ K to $T_{ad} = 2325$ K at $T_{pr} = 900$ K.
 102 The increase of initial temperature T_{pr} leads to slightly decreases of CO₂ and H₂O molar fractions because of their
 103 thermal dissociations, with the correlated increases of CO and H₂ molar fractions in the equilibrium gas
 104 composition. The high concentration of nitrogen ($[N_2] = 49\%$ vol.) in BFG has a significant impact on NO

105 formation. This shows that reactants preheating might have a potential impact on pollutant emissions such as CO
 106 and NO, and that would have to be considered during development of practical applications.

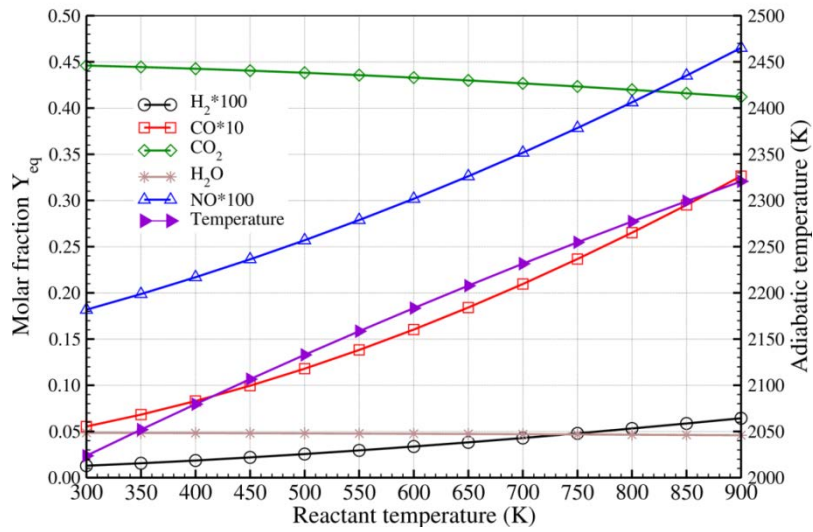

107
 108 Figure 2. Adiabatic temperature and equilibrium species molar fractions with initial reactant temperature T_{pr}
 109 for a BFG-O₂ stoichiometric mixture.

110 3.2. Laminar burning velocity and flame thickness

111 Simulations of mono-dimensional freely propagating premixed laminar flames of BFG-O₂ stoichiometric mixtures
 112 are performed to determine laminar burning velocity S_L and flame thickness δ_{th} . These properties are essential to
 113 evaluate the flame stabilization in the wake of burner nozzle. The laminar burning velocity is useful to compare
 114 the reactant conditions in terms of propagating efficiency when a leading-edge occurs. Linked to the heat diffusion,
 115 the flame thickness indicates the ability of the flame to be stable in the wake of a lip [Juniper 2003]. Flame
 116 thickness is deduced from the temperature profile across the flame front as the ratio between the temperature
 117 difference ($T_{ad} - T_{pr}$) and the maximum temperature gradient across the flame front. Figure 3 presents the
 118 changes of S_L and δ_{th} as a function of the initial reactant temperature.

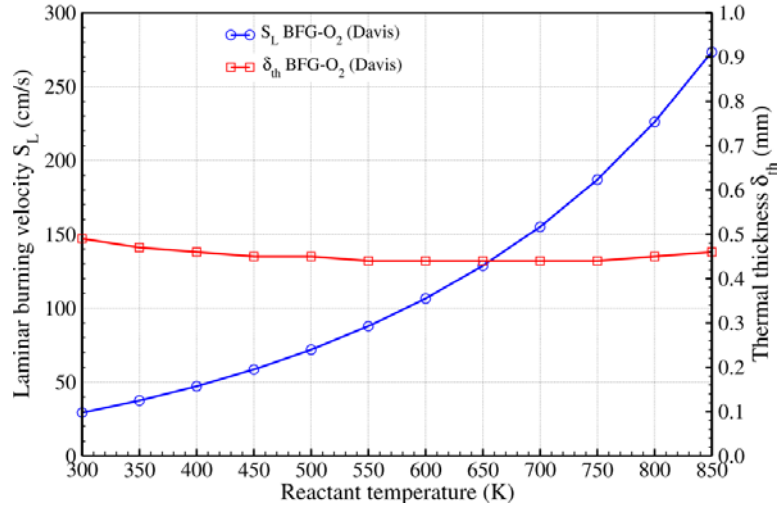

Figure 3. Laminar burning velocity S_L and flame thickness δ_{th} with reactants preheating temperature T_{pr}

119
120

121 The laminar burning velocity becomes nine times higher when T_{pr} varies from 300 K to 850 K. The sensitivity of
122 the S_L with temperature is commonly described by a power law expression such as:

123
$$\frac{S_L(T_{pr})}{S_L(T_0=300K)} = \left[\frac{T_{pr}}{T_0} \right]^\alpha \quad (1)$$

124 The exponent α in the present case is 1.72. This represents a significant increment in the flame velocity under
125 these conditions, compared to several studies carried out with preheated methane-air flames where the obtained α
126 value was in the range of 1.575 to 1.68. [Mishra 2003, Sharma 1981, Han 2007, Liao 2004, Lamige 2015].

127 High values of S_L reached with reactants preheating provide a potential to ensure the oxyfuel flame stabilization,
128 even with very low calorific value fuel gas. S_L increases almost one order of magnitude, when the adiabatic
129 temperature change is moderate. Thus, a significant flame stabilization enhancement can be achieved without
130 having a strong impact on the thermal process in an industrial facility.

131 Without preheating, the flame thickness of BFG-O₂ oxyfuel flame is high, $\delta_{th} \approx 0.5$ mm. When increasing T_{pr} , a
132 slightly decrease is observed. The narrowing of the temperature difference ($T_{ad} - T_{pr}$) due to preheating reactants
133 is compensated by an equivalent decrease of the temperature gradient. Conservation of wide thermal thickness
134 shows that the width of the low velocity zone in the wake of the lip's nozzle has to be kept large enough, as
135 significant interaction between flame front and small turbulent structures can be expected in a turbulent BFG-O₂
136 flame with such flame thickness [Juniper 2003].

137 3.3. Strain rate and flame blow off

138 In order to analyze the flame extinction in a turbulent preheated BFG-O₂ system, 1D diffusion counter-flow flame
 139 simulations were also carried out. These simulations allowed to highlight the strain effect on the BFG-O₂ flame
 140 stability and, to determine the critical strain rate K^* where the flame is blown off. In this configuration, the effect
 141 of the reactants preheating is studied by considering the same temperature for oxygen and BFG, i.e. on both sides
 142 of the diffusion flame. Figure 4 presents the adiabatic diffusion flame temperature when increasing the strain rate
 143 at different reactants inlet temperatures.

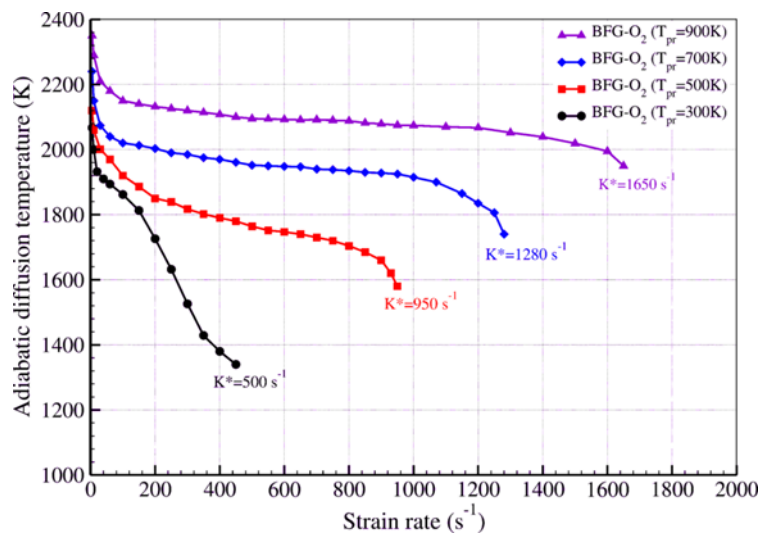

144
 145 Figure 4. Adiabatic flame temperature T_{ad} vs. with strain rate K of mono-dimensional for 1D counterflow diffusion flames.

146 For all preheating reactants temperatures, the progressive increase of strain in the diffusion flame induces a
 147 decrease of the adiabatic temperature before reaching the flame extinction limit at the corresponding critical strain
 148 rate K^* .

149 At ambient temperature, the adiabatic temperature decreases rapidly even from low strain rate values before
 150 reaching the limit where the flame is extinguished at $K^* = 500 \text{ s}^{-1}$, despite the use of oxygen as oxidiser. The
 151 reactants preheating leads to larger adiabatic temperature, as already observed in equilibrium calculations, as well
 152 as to a significant change in the slope of the adiabatic temperature with the strain rate. After a first decline of
 153 adiabatic temperature at low strains, the adiabatic temperature presents a plateau followed up by a second decline,
 154 up to the flame extinction limit. The range of strain rate of the plateau is wider at higher reactants temperature,
 155 showing in this way an enlarged flame stability limit. The critical strain rate at $T_{pr} = 500 \text{ K}$ is twice the ambient
 156 case ($K^* = 500 \text{ s}^{-1}$), and more than three times for $T_{pr} = 900 \text{ K}$.

157 All these simulations show the potential benefit of reactants preheating on oxyfuel BFG flame, in terms of flame
 158 stabilization and limits to extinguishment. The experimental studies carried out at both laboratory and industrial-
 159 scales are devoted to make real demonstrations of this potential.

160 **4. Oxyfuel burner adapted to LCV fuels**

161 *4.1. Burner configuration and operating conditions*

162 Based on previous experience of BFG oxyfuel combustion [Paubel 2007], a tri-coaxial burner configuration is
 163 chosen, with an annular BFG injection surrounded by a central (O_{2i}) oxygen injection and a peripheral (O_{2e}) oxygen
 164 injection (Figure 5). Thus, for fixed LCV fuel composition and global equivalence ratio, the oxygen distribution
 165 between the central and external flows will be used to control flame stability and length, heat transfer along the
 166 combustion chamber and pollutant emissions in the flue gases.

167 The oxygen distribution is quantified by a non-dimensional parameter R_o , defined from internal $Q_{O_{2i}}$ and external
 168 $Q_{O_{2e}}$ oxygen volumetric flowrates:

169
$$R_o = \frac{Q_{O_{2i}}}{Q_{O_{2i}} + Q_{O_{2e}}} \quad (2)$$

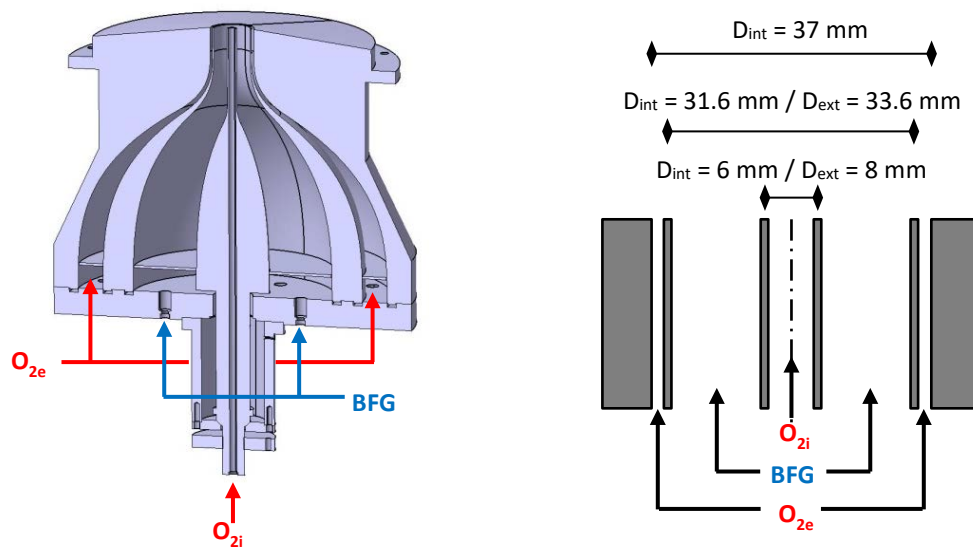

170 Figure 5. Isometric view of the tri-coaxial O_2 / BFG / O_2 burner (left) and diagram of the burner exit with external and internal diameters of
 171 the injections (right)

172 The burner is manufactured in Inconel 600 stainless steel in order to be able to supply hot gaseous fuels and
 173 oxygen. On the bottom of the burner, BFG and oxygen supplies are set longitudinally to avoid any direct impact
 174 of hot reactant on burner walls. For each annular flow, the injections impinge on small obstacles to induce their

175 expansion in the large volumes on the burner base, which then act as plenum chambers to ensure flow
 176 homogeneity. Progressive annular flows contractions made by convergent shapes allow to control the velocity
 177 profiles at the burner exit.

178 For lab-scale experiments, the burner is designed for a thermal power of 25 kW and a total equivalence ratio of
 179 $\phi = 0.96$. The same burner geometry is also considered for the semi-industrial scale experiments at nominal power
 180 of 180 kW. This corresponds to the thermal power target for reheating furnaces in the steel making industry
 181 application.

182 4.2. Original design rules for coaxial LCV burners

183 Previous experimental study has shown that the stabilization of a BFG-O₂ turbulent diffusion flame at 300 K is
 184 controlled by the convection velocity, $U_c = (U_{BFG} + U_{O_2})/2$, up to a limit of 10.5 m/s [Paubel 2007]. The
 185 stabilisation limit of such BFG-O₂ turbulent diffusion flame at the burner lip can be characterized by a critical
 186 Damköhler number Da^* which relates the interaction between a representative mixing time scale and the low
 187 chemical reactivity of BFG-O₂. Several authors have shown that the stabilisation of a turbulent diffusion flame in
 188 the region close to the burner exit is controlled by the burner lip width, which has to be large enough to enable the
 189 flame to be tucked in the region of low momentum behind the lip [Takahashi 1990, Juniper 2003, Candel 2006,
 190 Okateyama 2009]. Therefore, in the present work, the representative mixing time is defined as; $\tau_t = e/U_c$,
 191 associating the width of the burner lip e to the convection velocity U_c related to the large structures developed in
 192 the shear layer [Dahm 1992, Takahashi 1990, Rehab 1997, Villiermaux 2000]. The chemical time τ_{ch} can be
 193 estimated by the scalar dissipation rate χ_q [Peters 2000]:

$$194 \quad \tau_{ch} = \frac{1}{\chi_q} = \frac{D}{Z_s^2 \cdot (1-Z_s)^2 \cdot S_L^2} \quad (3)$$

195 Thus, the expression of the Damköhler number Da is:

$$196 \quad Da = \frac{\tau_t}{\tau_{ch}} = \frac{e}{U_c} \cdot \frac{Z_s^2 \cdot (1-Z_s)^2 \cdot S_L^2}{D} \quad (4)$$

197 In the present work, the value of the critical Damköhler number at 300 K ($Da^* = 0.004$) is adopted as a control
 198 parameter of the flame anchorage to the burner lip e and is also used to design the tri-coaxial burner, in order to
 199 reach the limit of stability at ambient reactant temperature. First, the chemical time is determined from
 200 thermochemical calculations of the diffusivity D , the stoichiometric mixture fraction Z_s and the laminar burning

201 velocity S_L . The mixing time τ_t depends on the lip width and the convection velocity U_c . Considering that the
 202 thermal thickness of BFG-O₂ premixed oxyfuel flame remains constant ($\delta_{th} \approx 0.5$ mm) whatever reactant
 203 temperature (Figure 3), the width of the burner lips is chosen equal to 1 mm, in order to favour stabilization of
 204 attached BFG-O₂ diffusion flame and to delay the transitions to lifted flame regime and its extinction afterwards
 205 [Juniper 2003, Otakeyama 2009].

206 Following this methodology, the maximum convection velocity U_c^* can be determined for each reactant
 207 preheating from the critical Damköhler number ($Da^* = 0.004$). Figure 6 presents the convection velocity according
 208 to the reactant preheating temperature T_{pr} . The exponential increase in U_c points out that the reactant preheating
 209 will ensure undoubtedly the stabilization of BFG-O₂ turbulent diffusion flames in the inner and outer shear layers.
 210 In this tri-coaxial burner geometry, two convection velocities, U_{ci} and U_{ce} , can be defined in the inner (O_{2i}-BFG)
 211 and outer (BFG-O_{2e}) mixing layers respectively. Then, dimensions of the injection exit diameters of the lab-scale
 212 burner are chosen to have inner U_{ci} and outer U_{ce} convection velocities closed to the critical convection velocity
 213 U_c^* at $T_{pr} = 300$ K for nominal operating conditions. Tri-coaxial injections diameters are given in Figure 5. The
 214 burner is designed to be at the limit of stability without preheating using the criterion U_c^* , in order to investigate
 215 how the reactant preheating enhances the flame stability. Figure 6 illustrates the expected enhancement: when
 216 increasing reactant temperature, the linear increases of both U_{ci} and U_{ce} are weak compared to the exponential
 217 increase of U_c^* . This should favour the stabilization of BFG-O₂ flames in the inner and outer shear layers.

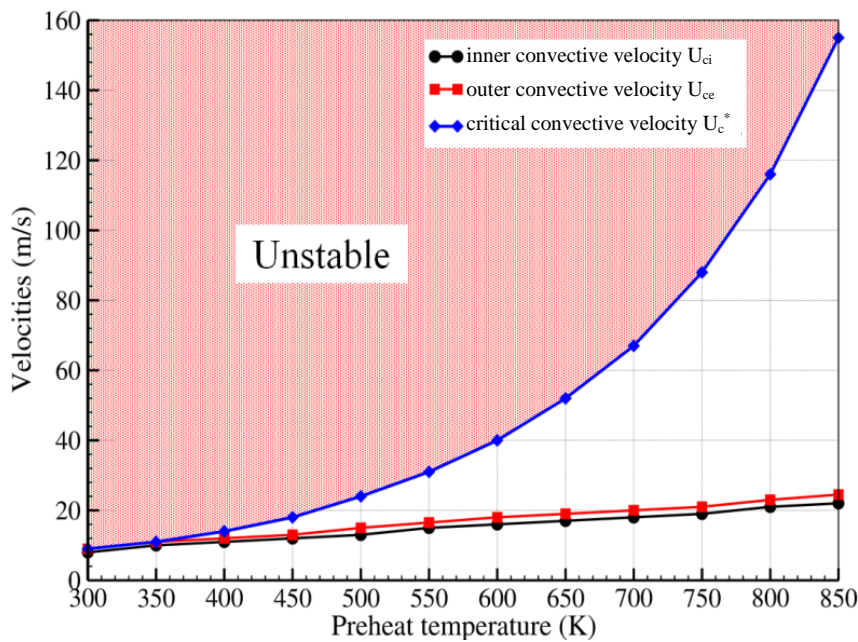

218
 219 Figure 6. Effect of reactants temperature T_{pr} on BFG-O_{2i} and BFG-O_{2e} convective velocities for the tri-coaxial burner,
 220 compared to the critical value of the convection velocity U_c^*
 221

222 5. Experimental study on the lab-scale facility

223 5.1. Experimental setup

224 The BFG-O₂ tri-coaxial burner is installed on the lab-scale facility at CORIA laboratory, which consists of a
225 cylindrical combustion chamber (length = 1 m - dia. = 0.4 m) with refractory walls and several optical accesses.
226 The synthetic BFG mixture is provided by a dynamic mixing system of pure gases, controlled by a set of mass
227 flow-meters. Three independent electric heating systems are used to control the preheating of the fuel mixture and
228 the two oxygen supplies for central and outer flows. The facility is instrumented with a gas analyser Siemens
229 Oxymat 61 - Ultramat 23 for on-line measurements of O₂, CO₂, CO₂ and NO_x in the flue gases, and several K-
230 type thermocouples are installed close to the combustion chamber wall to obtain longitudinal temperature profile.
231 The structure of BFG-O₂ flame is obtained by OH* chemiluminescence imaging performed through the optical
232 access located close to the burner exit. Chemiluminescence images are collected with a Princeton PI-MAX 4 ICCD
233 camera (1024 x 1024 pixels - 16 bits) equipped with f/2.8 25 mm UV objective lens associated with two Schott
234 UG11 filters. For each flame, a series of 500 instantaneous images, with an exposure time of 100 μs, is recorded
235 in order to determine a representative mean image. The axial symmetry of the burner allows for reconstructing the
236 mean tomographic structure of the BFG-O₂ flame. This is carried out using Abel's inversion post-processing of the
237 average OH* chemiluminescence image.

238 5.2. Stability diagram and flame structures for ambient reactant temperature

239 Figure 7 presents the flame stability diagram without any reactants preheating. For a given thermal power, the tests
240 were carried out at a fixed equivalence ratio and increasing the oxygen distribution Ro. The results show that the
241 oxyfuel BFG flame is stabilized in a narrow range of thermal power and oxygen distribution, which are lower than
242 the nominal operating conditions. Slight modifications in the oxygen distribution quickly induce the appearance
243 of fluctuations and disturbances in the flame. Thus, several flame structures are observed from a minimum Ro
244 value of 10%,

245 For low thermal power, double concentric flames attached to the burner lips are observed. Mean structure of these
246 flames - labelled 'type A' - is presented in Figure 8 by the mean OH* chemiluminescence image integrated along
247 the line of sight, and the corresponding mean tomographic image resulting from the Abel's inversion at the
248 operating conditions corresponding to 12.5kW, Ro of 10% and T_{pr} of 300K. A diffusion flame is stabilized from
249 the burner exit in both the BFG-O_{2i} and BFG-O_{2e} shear layers. Two types of A flames are distinguished depending

250 on the CO emissions. For the lowest tested thermal power corresponding to 10 kW, CO concentrations higher than
 251 300 ppm are measured in the flue gas for A1 type flame as in the stability diagram. With slight increments of
 252 thermal power to 12.5 kW the CO emission levels are less than 20 ppm, showing that larger flowrates enhance
 253 turbulent mixing and ensure complete combustion (A2 flame in the stability diagram). Despite the significant high
 254 nitrogen concentration in BFG, NO_x emissions are very low (less than 15 ppm) for all flames, thanks to their low
 255 heat release density.

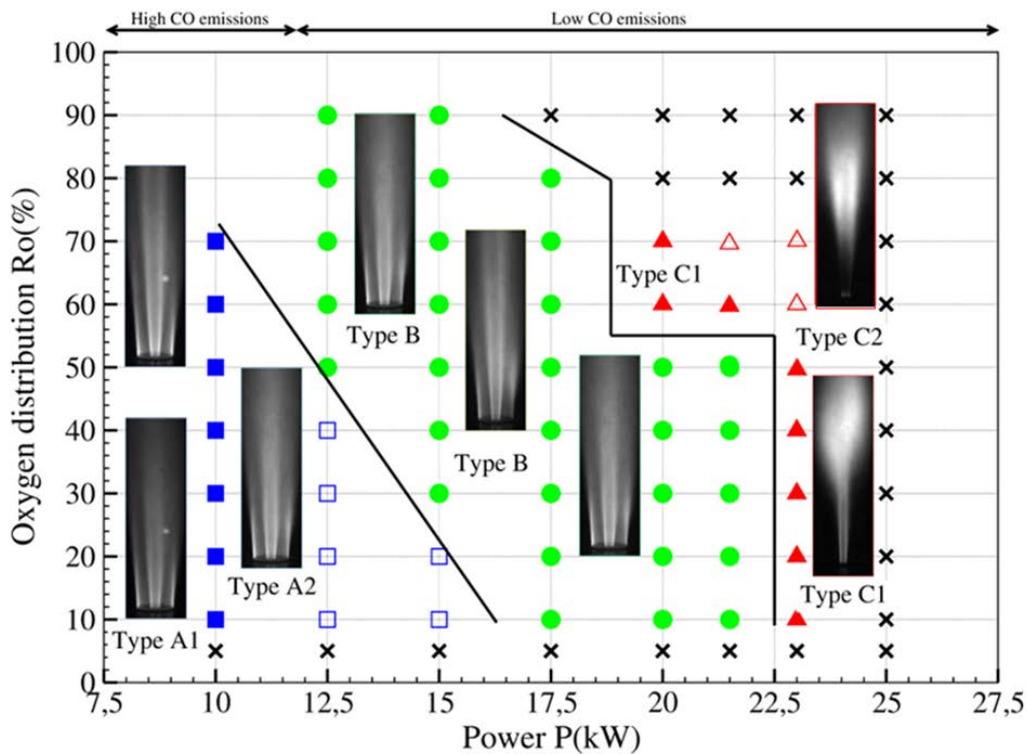

256
 257 Figure 7. Stability diagram of oxyfuel BFG flames without reactants preheating. (blue filled square: A1 flame - blue open square: A2 flame -
 258 green circle: B flame - red filled triangle: C1 flame - red open triangle: C2 flame - black cross: blown-off flame)
 259

260 When increasing P and/or Ro, double concentric attached flame (A type) still exists up to the first transition, where
 261 some local fluctuations of the external annular BFG-O_{2e} flame are observed. For these flames, defined as 'type B'
 262 on the stability diagram, the intermittent extinctions generate a dissymmetry in the mean structure of the external
 263 annular flame (Figure 9). This effect is even more pronounced when increasing P and/or Ro and lead to a third
 264 flame structure, Type C1, where the external flame is lifted-off. For this, the flame stabilization is ensured by the
 265 attached central BFG-O_{2i} flame, such as it is shown in Figure 10. For higher thermal power and central oxygen
 266 flowrate, some local extinction is observed in the inner BFG-O_{2i} flame, (Type C2 - Figure 11), before it is totally
 267 blown-out (see stability diagram in Figure 7).

268

269

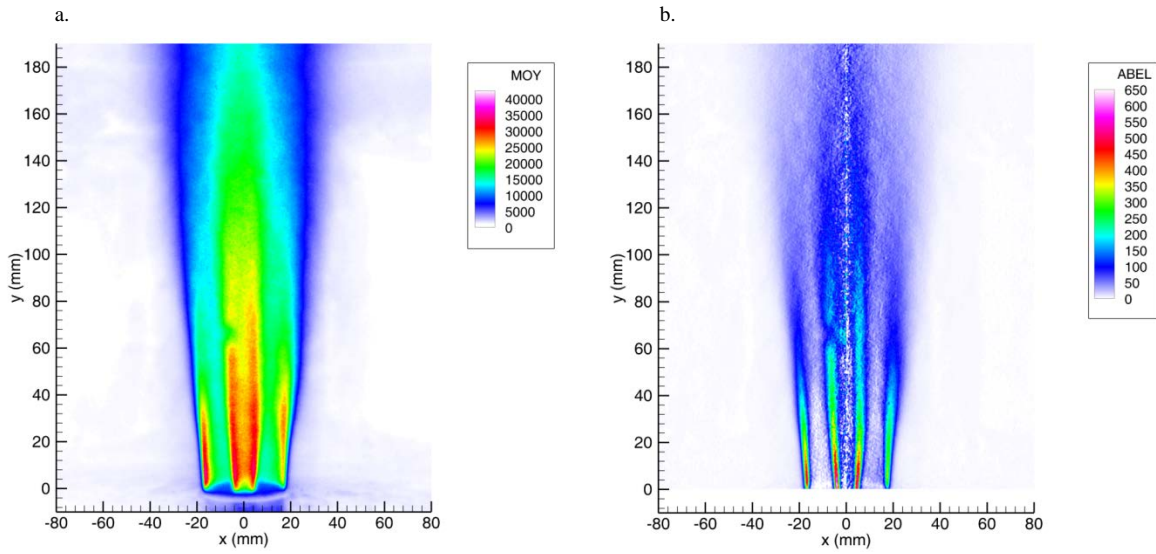

Figure 8. The structure of 'type A' oxyfuel BFG flame for 12.5kW, Ro of 10% and $T_{pr} = 300K$.
a: Mean OH* chemiluminescence image. b: Tomographic image reconstructed by Abel's inversion.

270
271
272
273
274

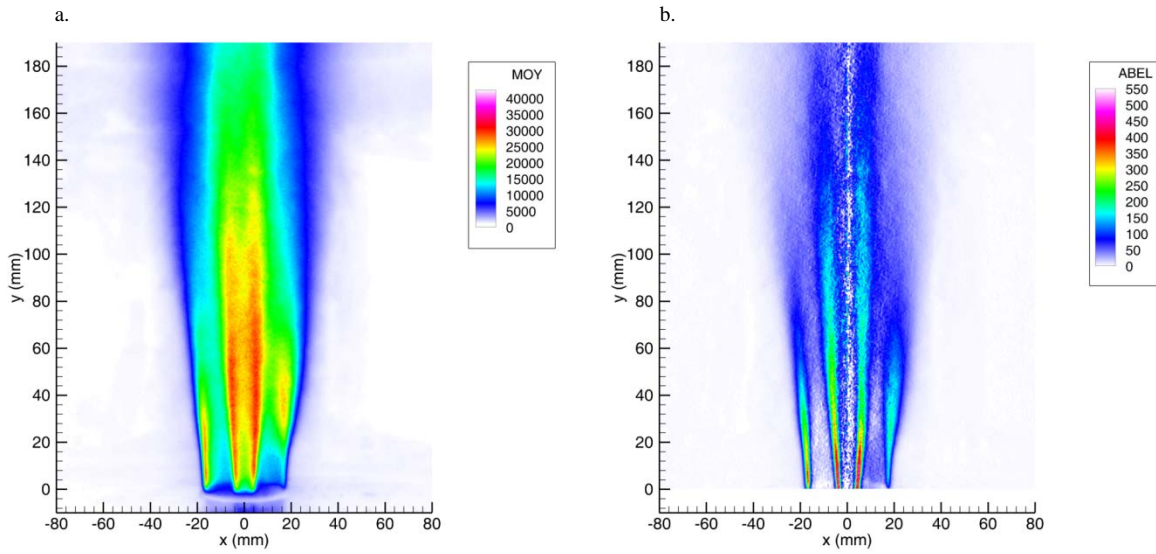

Figure 9. The structure of 'type B' oxyfuel BFG flame for 17.5kW, Ro of 40% and $T_{pr} = 300K$.
a: Mean OH* chemiluminescence image. b: Tomographic image from Abel's inversion.

275
276
277
278
279

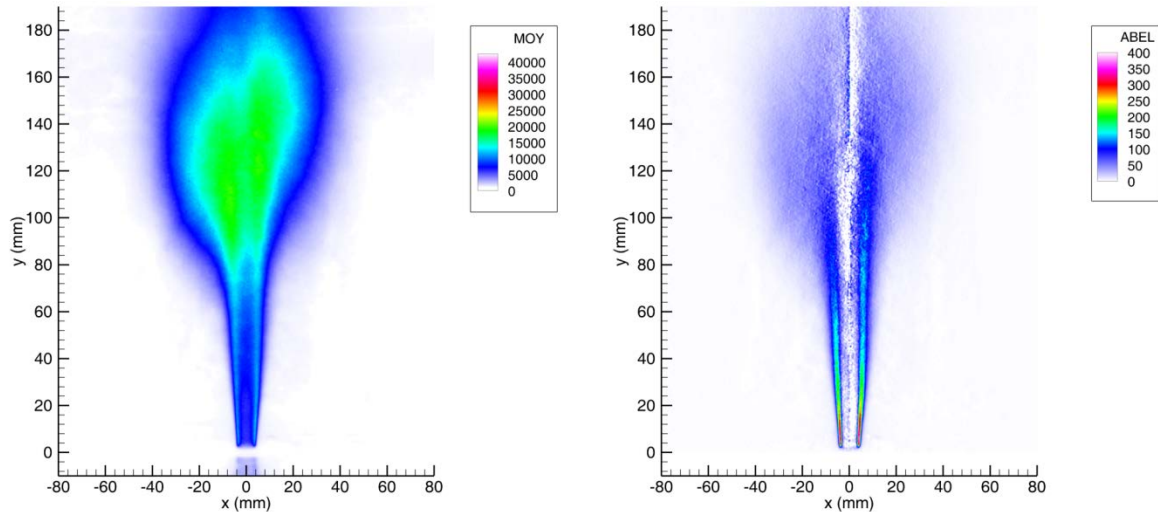

Figure 10. The structure of 'type C1' oxyfuel BFG flame for 23kW, Ro of 40% and $T_{pr} = 300K$.

a: Mean OH* chemiluminescence image. b: Tomographic image from Abel's inversion.

280
281
282
283
284

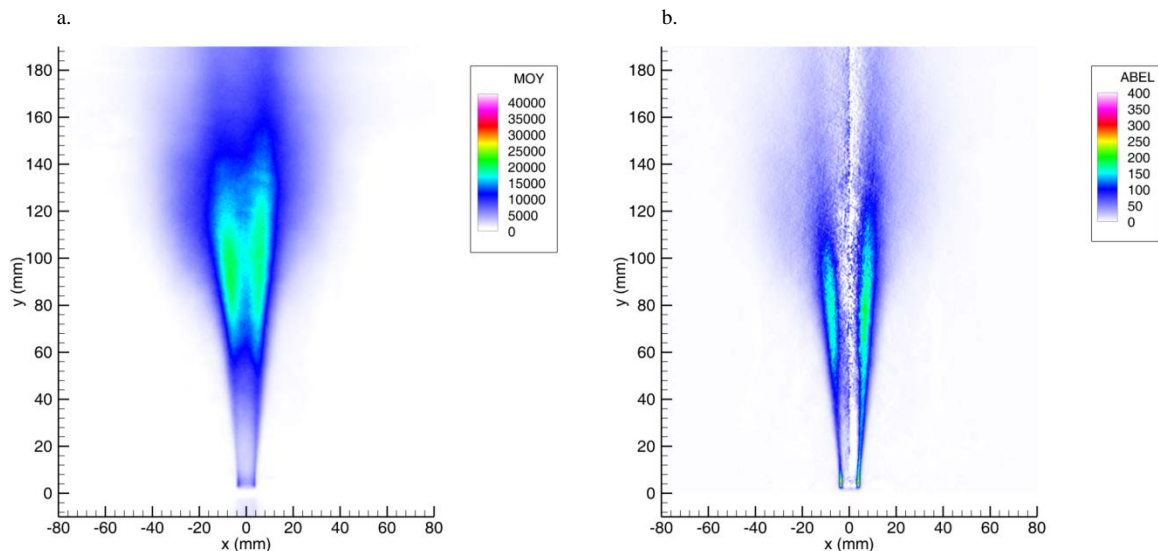

Figure 11. The structure of 'type C2' oxyfuel BFG flame for 23kW, Ro of 60% and $T_{pr} = 300K$

a: Mean OH* chemiluminescence image. b: Tomographic image from Abel's inversion.

285
286
287

288 The local intermittent stabilization and the flame extinctions result from the local features of mixing and shear in
 289 the BFG-O₂ layers, which are different for external and internal diffusion flames. The thin external oxygen annular
 290 flow with high velocity induces a rapid entrainment of combustion products recirculating in the furnace, which
 291 increases the dilution rate in the outer diffusion flame. This explains the appearance of local fluctuations (flame
 292 transition from A to B), followed by the external flame lifting-off (transition from B to C), whereas no effect of
 293 external dilution is expected at the central BFG-O_{2i} flame.

294 For this central BFG-O_{2i} flame, large Ro values may induce too large strain in the BFG-O_{2i} shear layer to stabilize
 295 a turbulent diffusion flame, when corresponding convection velocity U_{ci} is higher than U_c^* . This is brought out
 296 by drawing a second representation of the stability diagram with BFG and inner oxygen injection velocities (Figure

297 12). The transition between attached and lifted central BFG-O₂ flame corresponds then to the changeover from
 298 C1 flames (red filled triangles) to C2 flames (red open triangles). Considering that this transition occurs at a critical
 299 shear for the diffusion flame stabilization, the limit is expressed as the threshold value of the convection velocity
 300 $U_{Ci}^* = (U_{BFG} + U_{O2i})/2$ [Paubel 2007]. This value was experimentally determined from the stability diagram as
 301 $14.5 \text{ m} \cdot \text{s}^{-1}$ at 300K, slightly higher than the previous one, $10.5 \text{ m} \cdot \text{s}^{-1}$, which was obtained in a quadri-coaxial
 302 configuration with lower lip thickness ($e = 0.5 \text{ mm}$), using a surrounding annular CH₄/O₂ flame [Paubel 2007].
 303

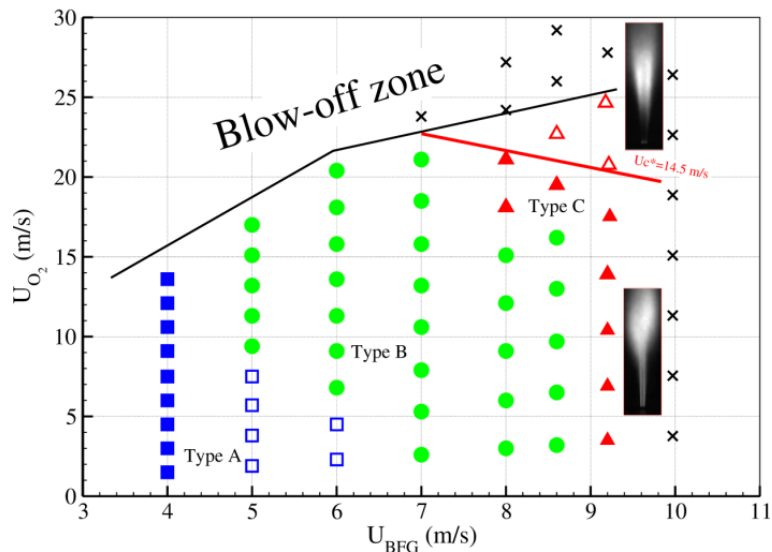

304
 305 Figure 12. Stability diagram of oxyfuel BFG flames as function of BFG and inner oxygen injection velocities, U_{BFG} and U_{O_2} respectively,
 306 without reactants preheating. (blue filled square: A1 flame - blue open square: A2 flame - green circle: B flame - red filled triangle: C1 flame
 307 - red open triangle: C2 flame - black cross: blown-off flame)

308 5.3. *Stability diagram and flame structures with reactants preheating at 600K*

309 The effect of reactant preheating on flame stabilization is illustrated in this section for both BFG and oxygen
 310 preheating temperature of 600 K. The same test procedure as for non-preheated experiments is carried out in order
 311 to produce the flame stability diagram presented in Figure 13. For this, having variations of the thermal power and
 312 increasing Ro , different flame structures and stability limits are obtained.

313 These results show clearly the benefits of reactants preheating. The presence of double attached A2 flames with
 314 low pollutant emissions is extended from 15 kW without reactants preheating, up to 25 kW such as it is shown in
 315 Figure 13. Same flame characteristics as fluctuating B flames, external lifted C flames or non-stable flames have
 316 also been observed, as in the non-reactants preheating case presented in Figure 7.

317

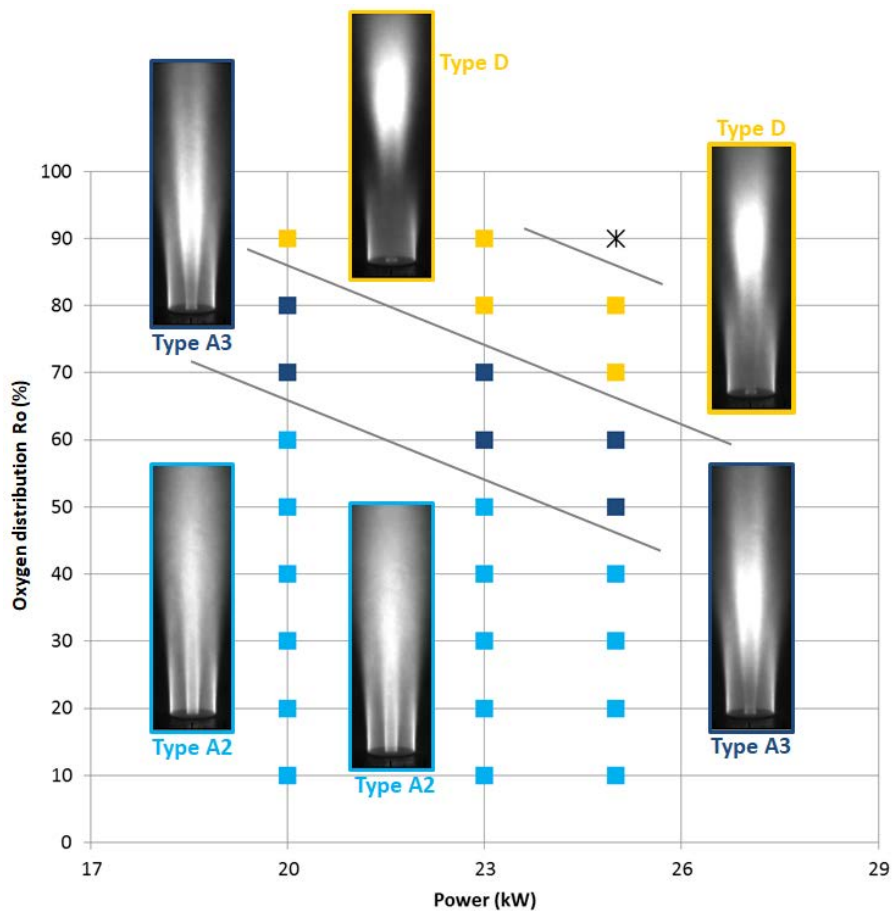

318
319
320

Figure 13. Stability diagram of oxyfuel BFG flames generated with reactant preheating at $T_{pr} = 600$ K. (light blue square: A2 flame - dark blue square: A3 flame - yellow square: D flame - black cross: blown-off flame)

321
322
323
324
325
326
327
328
329
330
331
332
333

Double attached flames A1 and A2 present similar topologies with maxima OH^* chemiluminescence occurring directly from the burner exit (Figure 8). With reactants preheating, another sub-type A3 of double attached flame can be defined where the central BFG- O_{2i} flame exhibits a maximum of OH^* chemiluminescence downstream from the burner exit shown in Figure 13. This occurs due to the large momentum flux in the central oxygen jet at high Ro value. At this condition an additional increase of thermal power, or of the inner oxygen injection raises the shear of the BFG- O_{2i} flame which is then lifted-off, whereas the outer BFG- O_{2e} flame is kept attached to the burner, leading to Type D structure observed in Figure 14. Therefore, the stability limit of preheated BFG oxyfuel flames seems to be more sensitive to the strain in the inner BFG- O_{2i} shear layer than to the strain in the outer BFG- O_{2e} shear layer. When increasing Ro , preheating of reactants makes the flame still stable even at higher momentum of the inner jet. This comes from the highly stable external BFG- O_{2e} flame, which acts as a protective pilot flame supplying sufficient heat to ensure the ignition of the internal BFG- O_{2i} flame downstream.

CO and NO_x emissions measured in the flue gas reached very low levels, less than 15 ppm, for all reactants preheating temperatures. In addition to this, no significant changes are observed during the transitions between

334 flame types. This shows that the reactants preheating with oxyfuel combustion for flame stabilization has no
 335 negative impact on the environmental impact of LCV fuels combustion due to the presence of inert species in the
 336 fuel.

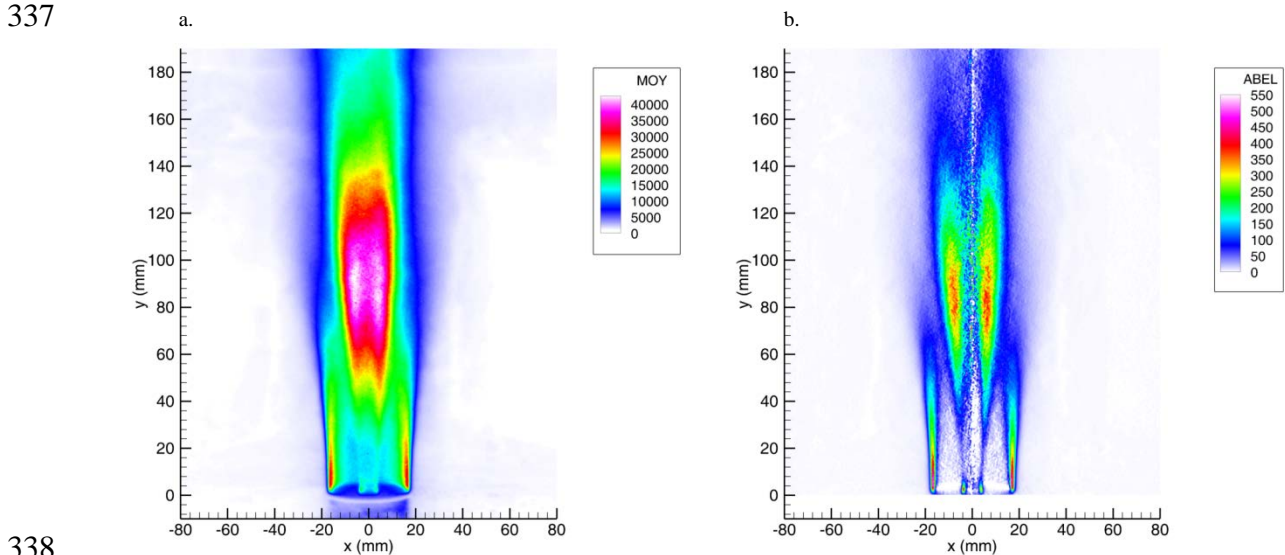

338
 339 Figure 14. The structure of 'type D' oxyfuel BFG flame for 25kW, Ro of 60% and $T_{pr} = 600K$.

340 a: Mean OH* chemiluminescence image. b: Tomographic image from Abel's inversion.

341 5.4. *Oxyfuel BFG flames stability limits with reactants preheating*

342 The effect of the reactants preheating on the stability of an oxyfuel BFG diffusion flame is studied by analysing
 343 the transitions of the inner BFG- O_{2i} flame. For this, the stability diagrams and associated flames topology are
 344 presented on Figure 15 as a function of BFG and inner oxygen O_{2i} velocities for 3 thermal powers (respectively
 345 20, 23 and 25 kW) at different preheating temperatures.

346 For these particular cases, there are no transitions between A type flames to B or C types, as shown previously
 347 when the reactants are preheated at 600K. For $T_{pr} \geq 400 K$, the limit of stability of the BFG- O_{2i} flame corresponds
 348 to the transitions between the A2 and the D flames. Then, the threshold value of the convection velocity $U_{Ci}^* =$
 349 $(U_{BFG} + U_{O_2})/2$ is experimentally determined from each stability diagram as a linear limit between the A2 and the
 350 D flames (Figure 13). For each preheating temperature, the critical convection velocity U_C^* and the corresponding
 351 Damköhler number Da^* are shown in the stability diagrams in Figure 15 where a significant increase of U_C^* with
 352 T_{pr} is observed. Whereas Damköhler number Da^* is almost constant confirming the assumption adopted for the
 353 burner design methodology.

354

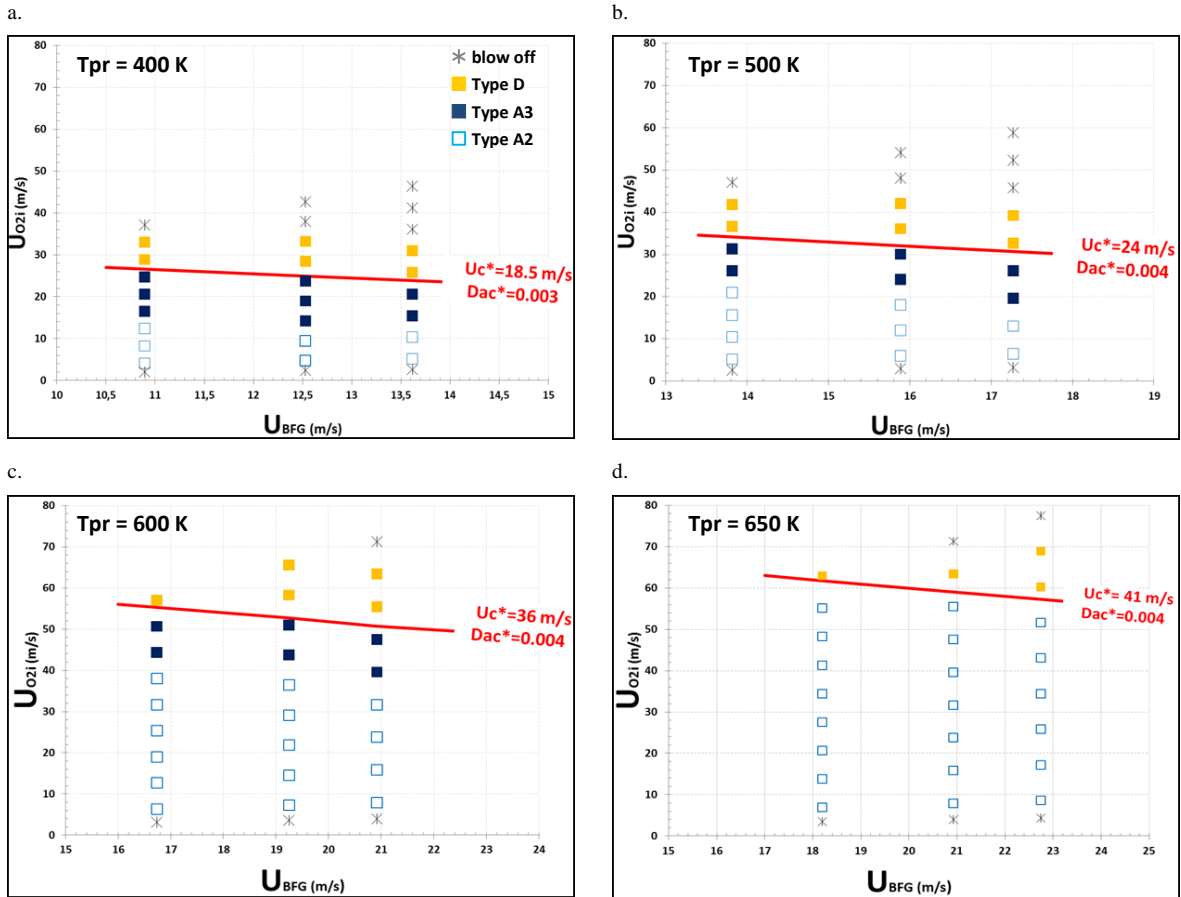

355 Figure 15. Stability diagrams of oxyfuel BFG flames as function of BFG and inner oxygen injection velocities, U_{BFG} and U_{O_2i} respectively,
 356 with different preheating temperatures. (light blue square: A2 flame - dark blue square: A3 flame - yellow square: D flame - black cross:
 357 blown-off flame)

358 Variations of experimental critical convection velocities with reactants preheating temperature is gathered on
 359 Figure 16, and compared to the theoretical one obtained with the model presented in section 4.2. Considering the
 360 precision of the experimental analysis caused by the measurements uncertainties and the approximations of the
 361 theoretical model, a good agreement between the theoretical and experimental values at 25 kW is observed. These
 362 results show the substantial advantage provided by reactants preheating on the oxyfuel flame stability, as well as
 363 the model suitability to help on the design of a burner adapted to LCV fuels.

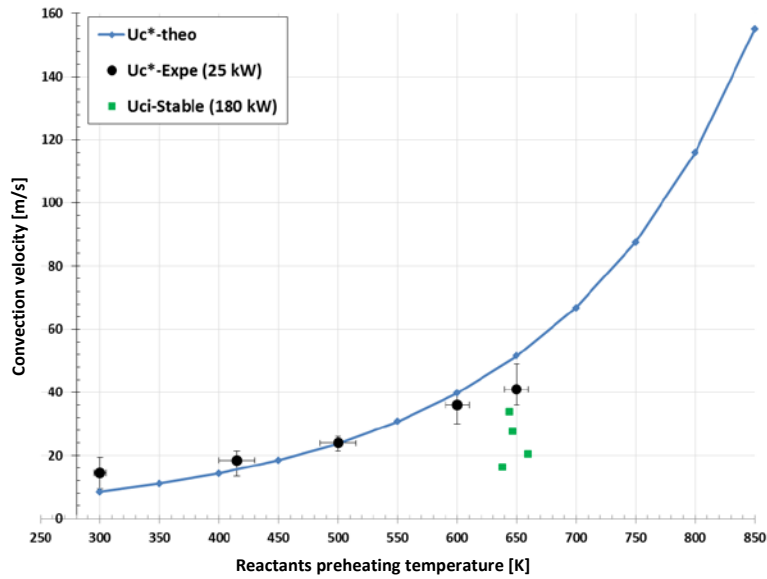

364

365

366

367

Figure 16. Convection velocity for the internal BFG-O₂ flame lifting vs. reactants preheating temperature for laboratory and semi industrial tests. (black dots: critical values from lab-scale experiments – blue line: theoretical limit - green squares: convection velocity for stable semi-industrial experiments).

368

6. Scale-up from laboratory to semi-industrial facility

369

370

371

372

373

374

375

376

377

378

379

380

381

382

383

384

Complementary to the detailed experimental study of preheated BFG oxyfuel combustion performed at laboratory scale, a second experimental study is done at nominal industrial scale to assess the effect of scaling-up. The semi-industrial facility at Air Liquide R&D Centre consists of a horizontal cylindrical combustion chamber, 5 m long and internal diameter of 1.1 m. The facility is insulated with ceramic fiber ($T_{\max} = 1700\text{K}$) and equipped with lateral port accesses for flame visualization and flue gases sampling. The large-scale burner has the same geometrical configuration as the lab-scale one, and its dimensions were determined from a scale-up methodology based on the criteria of critical convection velocity and flow velocity conservation for nominal operating conditions of 180 kW. Same BFG composition is chosen (Table 1) and is generated as a mixture from pure gases, such as the same procedure done at laboratory experiments. Two electric preheaters are used to enable continuous preheating of BFG and oxygen up to a maximum of 700 K and 823 K respectively.

The OH* chemiluminescence imaging is performed through the first lateral optical access, closed to the burner exit. The mean OH* image and its corresponding Abel's inverted image are presented on Figure 17 for the operating conditions corresponding to 180kW, Ro of 85%, T_{pr} (BFG) of 700K and $T_{\text{pr}}(\text{O}_2)$ of 550K. The same flame topologies as in the lab-scale experiments are observed. Preheating both reactants leads to the stabilization of a double attached flame, corresponding to a flame type A for all tested operating conditions, as they fulfilled the criteria of convection velocity lower than the critical one. These are shown as green squares, in Figure 16.

385 Tests within the burner turn-down ratio between 100 kW and 180 kW were done during the semi-industrial
386 experiments, having in this range very stable and attached flames type A2; as well as NOx emissions around 60
387 ppm in all the cases.

388 Having in mind that 180 kW thermal power corresponds to the nominal capacity of burner for application in a
389 reheating furnace of the steel making process; these results are first proof-of-concept of the advantage of the
390 oxyfuel combustion combined with reactants preheating in order to reach flame stability of LCV fuels, at this
391 industrial scale.

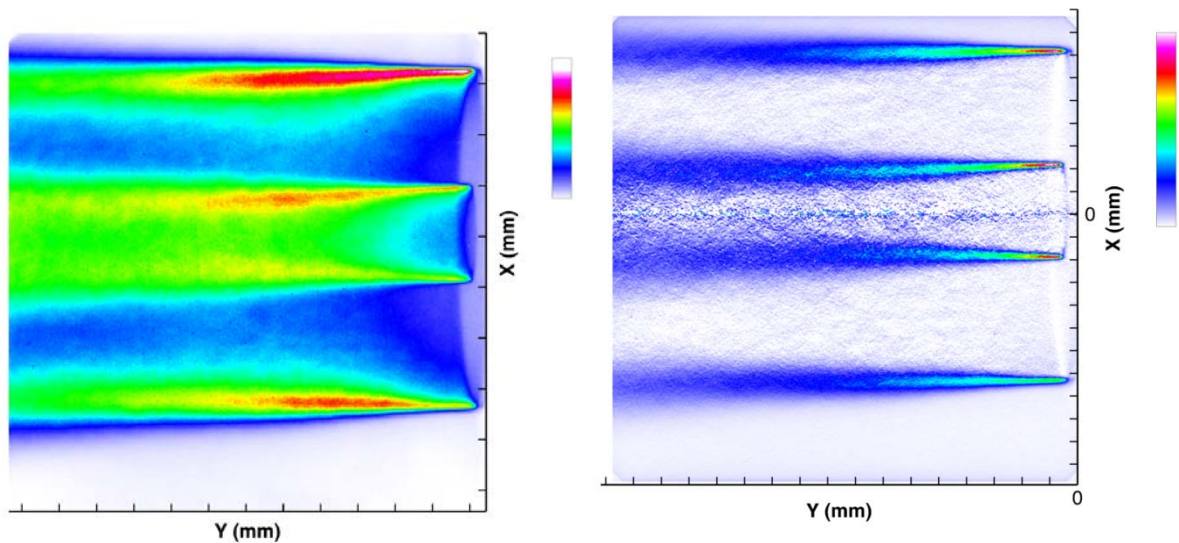

392 Figure 17. Oxyfuel BFG flame obtained on the semi-industrial facility under the conditions 180kW, $Ro = 85\%$, $T_{pr}(BFG) = 700K$ and
393 $T_{pr}(O_2) = 550K$.
394 Left: Mean OH* chemiluminescence image. Right: Tomographic image reconstructed by Abel's inversion.

395 7. Conclusions

396 This paper presents an experimental study of turbulent flame stabilization of low calorific value fuel gas by oxyfuel
397 combustion and reactants preheating. Characterisation of this alternative is based first on thermochemical
398 calculations which show and quantify the potential benefit of the reactants preheating on the stabilization of
399 oxyfuel LCV flames, throughout the increases in the adiabatic flame temperature, the laminar flame velocity and
400 the impact on the strain rate which provides an extension of the operational range before the flame blow off. These
401 results are used to develop an original methodology to design an oxyfuel LCV non-premixed burner, based on the
402 theoretical criteria associated to a critical Damköhler number; and at the same time allows to qualify the
403 enhancement of flame stability with reactant preheating.

404 Laboratory scale experiments demonstrate the advantage of oxyfuel combustion and reactants preheating for LCV
405 flames stabilization. Different flame structures based on the oxygen distribution are identified from OH*

406 chemiluminescence imaging. Stable type A flames are obtained where the two flames in the BFG-O₂ shear layers
407 are always attached to the burner exit. B and C flames occur when respectively the external flame presents some
408 local intermittent extinction or is lifted-off. A type D flame is also observed where the internal flame lifts at a large
409 critical convection velocity. A good agreement is obtained between the theoretical critical convection velocity and
410 the experimental results. Very low CO and NO_x emissions - less than 20 ppm - are measured in the flue gas for
411 all relevant operating conditions. Complementary semi-industrial experiments show the same flame characteristics
412 obtained at lab-scale, having always a double attached flame, corresponding to type A, for all operating conditions
413 at nominal industrial scale. These results validate the characterization of the physical phenomena leading to flame
414 stability and its quantification, as well as confirm the scale-up criteria used. In general, the combination of oxyfuel
415 combustion with reactants preheating allows to optimise the use of alternative energy sources as the low calorific
416 fuel gases on the steel manufacturing industrial plants, with potential energy savings, due to the reduction of natural
417 gas consumption. Although this technology is originally proposed for the steelmaking industry, it can also be open
418 to any other thermal process using low calorific value gases.

419 **Acknowledgments**

420 This study was performed in the framework of the 'CALOHRY' project joining Air Liquide, CMI GreenLine and
421 CORIA laboratory, with the financial support of ANR (ANR-12-SEED-0010-01).

422 **References**

- 423 [1] T. Komori, N. Yamagami, H. Hara. International Gas Turbines Congress. Tokyo (2003).
424 [2] C. Li, H. Tang, L. Jing, M. Zhu. Journal of Engineering for Gas Turbines and Power. 138. DOI: 10.1115/1.4031348 (2015).
425 [3] A.P. Giles, R. Marsh, P.J. Bowen, A. Valera-Medina. Fuel 182: 531–540 (2016).
426 [4] O. Gicquel, L. Vervisch, G. Joncquet, B. Labegorre, N. Darabiha, Fuel 82: 983-991 (2003).
427 [5] S.S Hou, C.H. Chen, C.Y. Chang, C.W. Wu, J.J. Ou, T.H. Lin. Energy Conversion and Management 52: 2758–2767 (2011).
428 [6] X. Paubel, Analyse expérimentale des oxy-flammes turbulentes non-prémélangées de gaz bas PCI. PhD Thesis INSA de
429 Rouen. 2007.
430 [7] X. Paubel, A. Cessou, D. Honore, L. Vervisch, R. Tsiava. Proc. Combust. Inst. 31: 3385-3392 (2007).
431 [8] Y. Joumani, B. Leroux, A. Contino, O. Douchamps, J. Behen, Glass Int 33: 32-38 (2010).
432 [9] J-W. Moon, S-J. Kim and Y. Sasaki. ISIJ International, 54: 63-71 (2014).
433 [10] A. Bâ, A. Cessou, X. Paubel, D. Honoré. Proc. European Combustion Meeting, Budapest, Hungary, 2015.
434 [11] S.G. Davis, A.V. Joshi, H. Wang, F.N. Egolfopoulos. Proc. Combust Inst. 30: 1283-1292 (2005).
435 [12] Wang J., Huang Z. Kobayashi H., Ogami Y. International Journal of Hydrogen Energy 37 (2012).
436 [13] M. Juniper, S. Candel. Journal of Propulsion and Power 19: 332-341 (2003).

- 437 [14] Y. Otakeyama, T. Yokomori, M. Mizomoto. Proc. Combust Inst. 32:1091–1097 (2009).
- 438 [15] D.P. Mishra. Fuel 82 1471-1475 (2003).
- 439 [16] S.P. Sharma, D.D. Agrawal, C.P. Gupta. Proc. Combust Inst. 18: 493-501 (1981).
- 440 [17] P. Han, M. Checkel, B. Fleck, N. Nowicki. Fuel 86: 585–596 (2007).
- 441 [18] S. Liao, D. Jiang, Q. Cheng. Fuel 83: 1247–1250 (2004).
- 442 [19] F. S. Lamige, K. M ; Lyons, C. Galizzi, M. Kühni, E. Mathieu, D. Escudié. Combust. Sci. And Technol. 187: 1937-58
- 443 (2015).
- 444 [20] S; Candel, M. Juniper, G. Singla, P. Scouflaire, C. Rolon. Combust. Sci. And Technol. 178:1-3, 161-192 (2007).
- 445 [21] W.J.A. Dahm, C.E. Frieler, G. Tryggvason. J. Fluid Mech. 241: 371–402 (1992).
- 446 [22] F. Takahashi, W.J. Schmoll. Proc. Combust. Inst. 23 (1990).
- 447 [23] H. Rehab, E. Villermaux, E.J. Hopfinger. J. Fluid Mech. 345: 357–381 (1997).
- 448 [24] E. Villermaux, H. Rehab, J. Fluid Mech. 425: 161–185 (2000).
- 449 [25] N. Peters. Turbulent Combustion. Cambridge University Press. 2000