



HAL
open science

The GAP methodology: A new way to design composite structures

Florian Neveu, Bruno Castanié, Philippe Olivier

► To cite this version:

Florian Neveu, Bruno Castanié, Philippe Olivier. The GAP methodology: A new way to design composite structures. *Materials & Design*, 2019, 172, pp.107755. 10.1016/j.matdes.2019.107755 . hal-02104764

HAL Id: hal-02104764

<https://hal.science/hal-02104764>

Submitted on 22 Oct 2021

HAL is a multi-disciplinary open access archive for the deposit and dissemination of scientific research documents, whether they are published or not. The documents may come from teaching and research institutions in France or abroad, or from public or private research centers.

L'archive ouverte pluridisciplinaire **HAL**, est destinée au dépôt et à la diffusion de documents scientifiques de niveau recherche, publiés ou non, émanant des établissements d'enseignement et de recherche français ou étrangers, des laboratoires publics ou privés.



Distributed under a Creative Commons Attribution - NonCommercial 4.0 International License

The GAP methodology: a new way to design composite structures

Florian Neveu¹, Bruno Castanié¹, Philippe Olivier¹

¹ Institut Clément Ader (ICA), Université de Toulouse, CNRS UMR 5312 - INSA - ISAE
Supaero - IMT Mines d'Albi - UPS, Toulouse, France

Abstract

With the growing demand for composite parts, more and more designs or re-designs are required to use such materials. This paper presents a new methodology for designing composite structures by considering three essential variables: the geometry, the architecture and the manufacturing process. The methodology proves to be useful during the pre-design phase of the project, when important decisions have to be taken regarding the choice of the manufacturing route and the investments needed. The methodology starts from the design (the geometry of which relies on the designer's creativity) and then gives clear insight into the possibilities offered by the concepts from a composite point of view. These include the types of architecture and technologies that are compatible as well as the manufacturing processes. The GAP methodology (Geometry, Architecture, Process) is intended to provide an efficient way to start a composite project by giving a broad overview of the possibilities and by reducing the risks of poor decisions at the very beginning of the project. In this article, innovative composite structure design issues will be presented before the methodology itself is explained. Two generic case studies are then presented to illustrate how the GAP methodology works.

Keywords: design methodology, composite materials, manufacturing processes, conceptual design

Highlights

- A new methodology is proposed for designing composite structures based on generation of concepts and specific aspects of composite structures
- Key information is provided on the relationships between design geometry, architectures and manufacturing processes for composite materials
- Two examples illustrate the methodology revealing the large number of solutions that composite structures can offer

1 Introduction

During recent decades, the use of composite materials has been constantly increasing in various fields of applications from the recreational to the aerospace sector. The advantages of composite materials can be significant for specific applications: in high-end products for example, where the mechanical properties of the structure are of utmost importance, the mass to stiffness ratio can be a strong argument for choosing a composite structure over a metallic one. Some figures have been given to demonstrate the positive impacts of weight savings in the automotive industry, regarding decreases in fuel consumption and CO₂ emissions [1]. The aim of lightweight construction is to preserve or even expand a product functionality while reducing its overall weight. Existing approaches for reducing mass include the use of less dense materials (metal foams, composite materials) or a decrease in the material volume by reducing wall thickness in key structural components. This has led to a huge development of composite parts in recent vehicles and the trend is still rising. Despite the increase of both manufacturing and maintenance costs, the benefits obtained on the mass are still largely profitable. For example in the two most recent programmes of Boeing and Airbus, for the 787 and the A350 respectively, composites make up about 50% of the mass and about 90% of the aerodynamic wet surface. Another major reason for the use of composite materials is that they make it possible to create simpler multifunctional structures thus drastically reducing the number of parts. A historic example is the new rotor hub for helicopters, designed by Aérospatiale (now known as Airbus Helicopters) in the 1970s, see Fig. 1 [2]. The benefits of this new design are shown in Table 1. It was possible to make weight savings and reduce part manufacturing costs while also greatly reducing maintenance costs. For instance, the introduction of composite blades in helicopters permitted a cost reduction of 13% [2]. The cost of possession is often lower for composite structures thanks to their non-sensitivity to corrosion and fatigue if they are correctly designed. More recently, Carello et al.

developed an innovative CFRP transverse leaf spring [3] with a weight reduction of 75% and a number of parts that was reduced from four to one (Fig. 2). Elixir Aircraft is currently designing an aircraft for general aviation implementing carbon fibres and a “one shot” wing. The company claims to have reduced the number of parts from 17,000 (for an equivalent metallic built aircraft) to 600 with their full carbon composite solution [4].

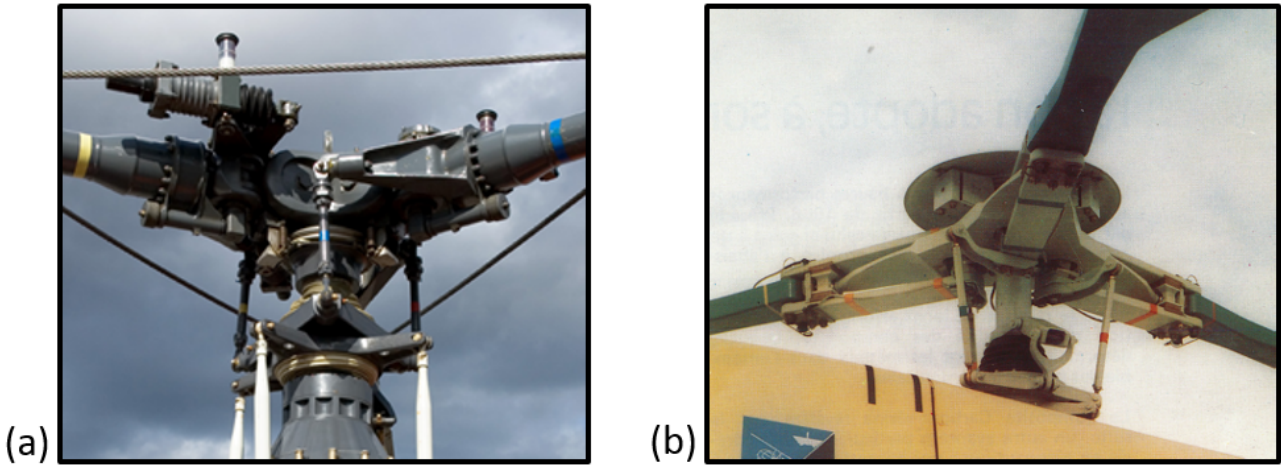

Figure 1: Rotor of the Alouette III (a) and "Starflex" rotor of the Ecureuil (b)

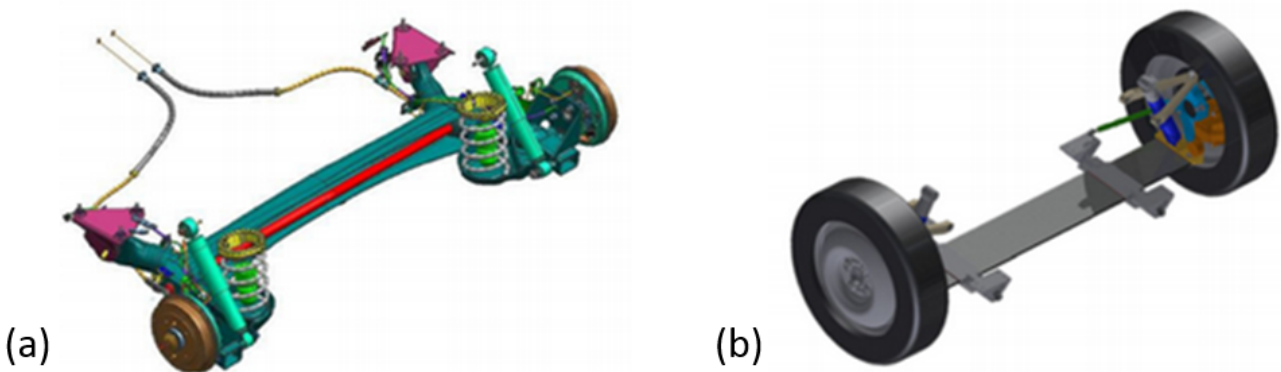

Figure 2: Initial design (a) and final composite design (b) of an automotive damping system from Carello et al. [3]

	Alouette III (1957)	Ecureuil (1974)	Savings (%)
Number of parts	377	70	81
Weight	(kg) 105	(kg) 55	48
Number of bearings	30	0	100
Number of seals	45	0	100
Grease points	22	0	100
Cost	100	45	55

Table 1: Savings with the "Starflex" conception

Thus, composite part manufacturers or industries aiming to move to composite solutions are facing challenges in composite design. The large choice of material compositions (i.e. matrix and fibres combinations), architectures and manufacturing processes makes the design process complex and difficult, as the designers face a hyper-choice of materials and technologies that can be overwhelming. Most of the time, designing composite is understood as, and limited to, the choice of stacking and sizing using the TSAI method or derivative, with or without an optimization scheme [5–11] because the geometry is already constrained. For example, in the latest generation of aircraft, like the B787 or the A350, the fuselage geometry is almost the same as in the previous generation of metallic aircraft with a thin skin, stiffeners and circumferential frame [12]. Thus this step in the history of composite in aircraft is known as “black metal”. In car bodies, the evolution is almost

the same since new composite parts are proposed to directly replace metallic parts or subcomponents [13]. Of course, introducing such complex materials remains a strong challenge and this step is necessary. In this context, some authors have proposed very interesting and useful methods for selecting materials [14–20], in general cases or more particularly, for sandwich structures [21, 22]. These approaches will help the designers but it is also well known that “In composite, materials do not pre-exist the structure”, highlighting that a composite part is only obtained after a manufacturing phase, which depends on industrial constraints such as the scale of production, the certification requirements, the availability of materials, the size of the part, the cost, and many other constraints. Nevertheless, a limited number of authors have proposed general methods. Monroy Aceves et al. [23] have developed a methodology to help designers select a shortlist or optimum design of composite structure from a large number of alternatives and have applied it to a wind turbine blade [24]. The link between composite structure design and manufacturing methods remains to be established from a general point of view. Hambali et al. [25] have proposed a selection method for ranking five types of processes for manufacturing an automotive bumper beam based on six main selection factors and twelve subfactors. Bader [26] has assessed the manufacturing costs of a simple component with different composite materials and by different a priori manufacturing routes in the context of aeronautics. A simple comparison methodology is introduced on the basis of cost-performance efficiency. Eventually, engineers wishing to totally or partially redesign their product are faced with a very complex set of problems involving a large number of possibilities and challenging objectives such as a reduction of the number of parts (and, if possible, converging to a "one shot" solution [4]) with lower manufacturing costs. Fig. 3 summarizes the dilemma introduced here:

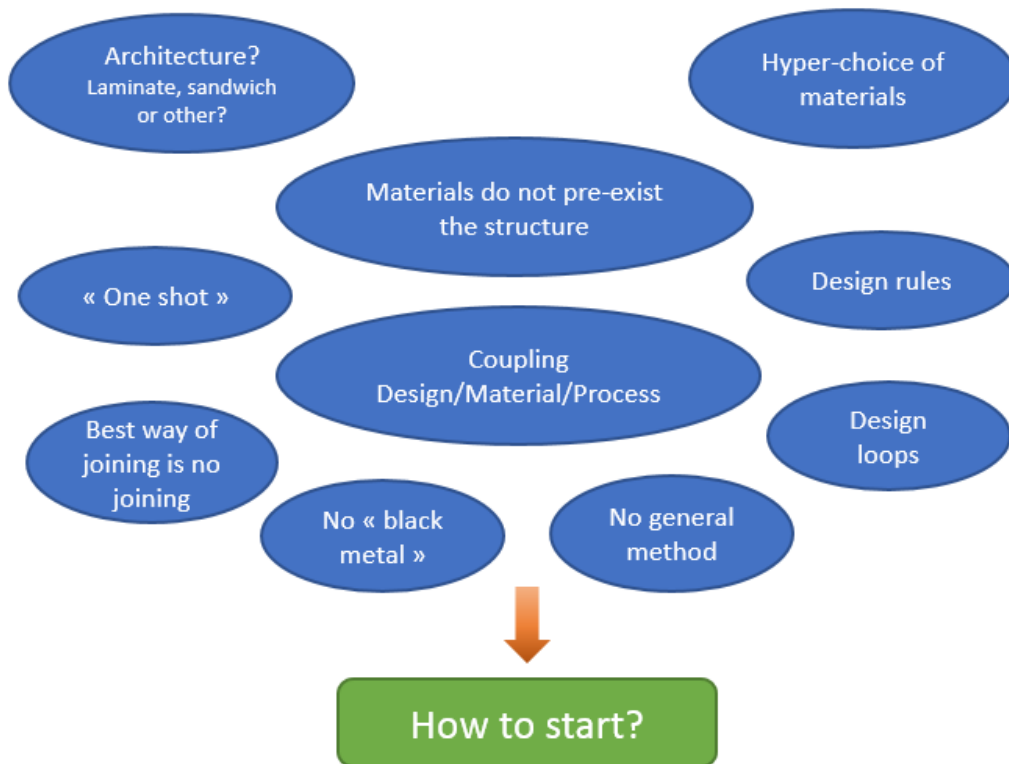

Figure 3: Dilemma arising in the process design for a composite part

Good knowledge and discussion with experts in the field of composite materials and structures will certainly help the engineer to take the right decisions at the right time in the choice of materials and architectures. However, according to the experience of the authors in many industrially-driven collaborative projects, the solutions may be strongly influenced by the past experiences of the experts or the pseudo-experts according to the proverb “If all you have is a hammer, everything looks like a nail”. This proverb can of course encourage the authors of the papers themselves to keep an open mind. So the GAP composite design methodology (acronym of Geometry, Architecture, Process) aims to be a starting point in a composite design process and, in this methodology, we would like to emphasize the importance of creating concepts in sufficient number and variety to tackle the issue of hyper-choice raised above. To introduce the method, this paper first presents its key feature: creativity in a design process. This is followed by a general overview of composite structure geometries, architectures and processes with key information for the development of the methodology. The GAP methodology itself is then presented and, in the last part, its use is illustrated through two case studies.

2 Key features of the GAP methodology

2.1 Creativity in the design process

It can be said that creativity is the primary quality needed by a designer in order to imagine innovative solutions. Howard defines the creative process as "a cognitive process culminating in the generation of an idea" and points out the differences with the design process defined as "a labour intensive process culminating in the proposal of a product or process" [27,28]. While these definitions show a real distinction between the two processes, we can be certain that the creative process is clearly embedded within the design process. Many design procedures are governed by simulations and calculations nowadays. Topology optimization [29], for instance, is commonly used and integrated in the design process. It certainly gives a good optimization for a given volume of matter, but the resulting shape needs to be reworked for manufacturability. There are many methods intended to stimulate creativity and help generate ideas and solutions to a given problem. The best known and most commonly used technique to date is brainstorming, which brings a group of persons together to work on a subject and think of a large number of different ideas, possibly creating links between them. No judgement should be made on the ideas and it is crucial to let the members propose unrealistic ideas which could be a source of inspiration. One alternative to the brainstorming method is the brainwriting, also called the 6-3-5 method [30], which is based on the same principle as brainstorming but can ensure equal participation for all the group members. Working with analogies can also be a good source of inspiration. It implies finding solutions based on those already known for similar functions. These analogies are particularly used in bio-inspired solutions, which are premised on the observation of nature [31]. In contrast, it is also possible to think by contradiction and then generate solutions to answer a given problem. A method called Evaporating Cloud [32] takes advantage of these contradictions; its name comes from the fact that the contradictions will disappear at the end of the methodology. The TRIZ method (theory of inventive problem solving) [33] is also well-known for its strong ability to solve technical problems by generating innovative solutions based on existing solutions. Creativity is fundamental for the methodology presented in this paper as it is the starting point of the GAP methodology. The first step is to create a large number of pre-concepts with information on only geometric boundaries, named the functional surfaces. It is important to scan every possibility when it comes to the design of a new product, simply because the probabilities of finding a good solution are higher if you pick up ideas from a large number of designs. As stated before, the use of various methods to stimulate creativity can thus prove useful here, the important thing being to think with total liberty and no restrictions. The importance of concepts should never be underestimated because they are the starting point of the final product. Having too few concepts strongly increases the risk of wasting time on a first bad idea and can result in a poor final solution as stated by professor Ullman [34]:

If you generate one idea, it is probably a poor one. If you generate twenty ideas, you may have a good one.
Or, alternatively
He who spends too much time developing a single concept realizes only that concept.

2.2 Geometry of composite parts

The shapes of metal parts have already been classified in mechanical industry in order to be used with different manufacturing routes, especially in metal and plastic forming industries. There are three main categories in this classification; prismatic shapes, thin-walled shapes and bulk shapes, as shown in Fig. 4 [35], where a geometric example is given for each shape. As a matter of fact, we will consider here that all these shapes could possibly be manufactured in composite materials. Prismatic parts can be referred to as beams, thin-walled parts as plate or shell structures and bulk parts could be seen as solids. For example, a composite fuselage is made of a thin skin (shell), circular frame (beams) and stringers (beams). These basic shapes have been manufactured since the beginning of the composite area. It is also possible to make solid shaped composite parts with very thick laminate like the Starflex shown in Fig. 1, which is made with about 400 plies of glass fibres or with recent ultra-thick laminates described in [36,37]. It is also possible to obtain solid, shaped composite parts by using very thick sandwich cores, forged carbon or 3D composites [38], or by stitching composite subparts together. Thus, today, shape should not be considered a limitation in composite design and nearly every part shape can be achieved. To sum up, in the creative design process of a new composite structure, the geometry can be a good starting point, by thinking about a beam-, plate- or solid-dominated shape.

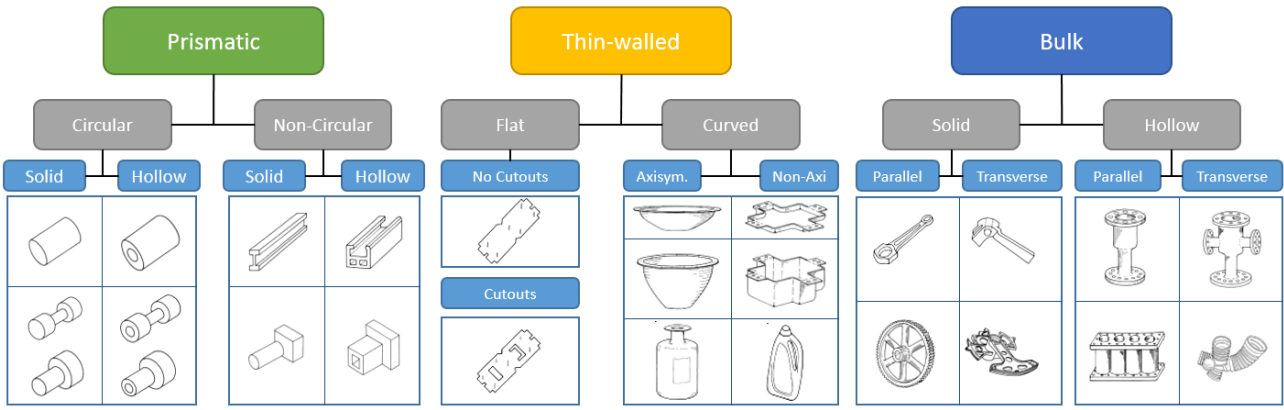

Figure 4: Shape classification according to CES EduPack [35]

2.3 Architectures of composite parts

To illustrate the concept of architecture of a composite structure, the reader is invited to consider the work of Krivanek and Yount from NASA on the issue of “Composite payload fairing structural architecture assessment and selection” [39]. With the shape of the fairing fixed, there are many possibilities for making the structure in composite materials, as illustrated in Fig. 5.

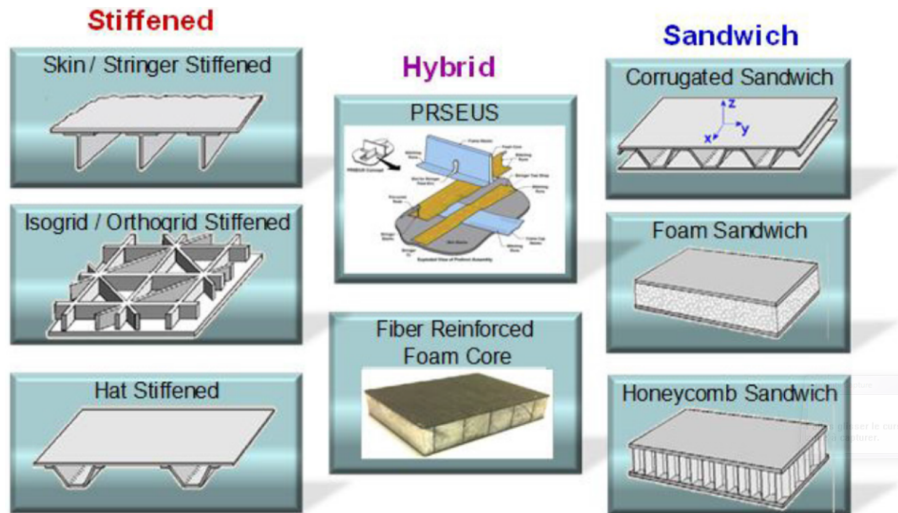

Figure 5: Composite construction technologies or architecture for evaluation of a fairing (reproduced from [39])

The authors classified the possible solutions in three relevant categories: stiffened, sandwich and hybrid. Another interesting case study is that of Urik and Malis [40] on an innovative wing for light aircraft. The solutions compared in this example are a traditional design with sandwich skins (Fig. 6a), a geodesic solution (Fig. 6b) and a corrugated sandwich structure (Fig. 6c).

This kind of classification can be extended to various other architectures and as in the preliminary and non-exhaustive review below. The first and most popular architecture is, of course, the laminate but it encompasses various sub-categories of technological solutions:

- Unidirectional or NCF based laminates [41–46]
- Thin or ultra-thin ply based laminates [47–52]
- Textile based laminates [53, 54]:
 - Woven [55–61]
 - Braids [61–64]
 - Knitted [65, 66]
- Glare [67–70]

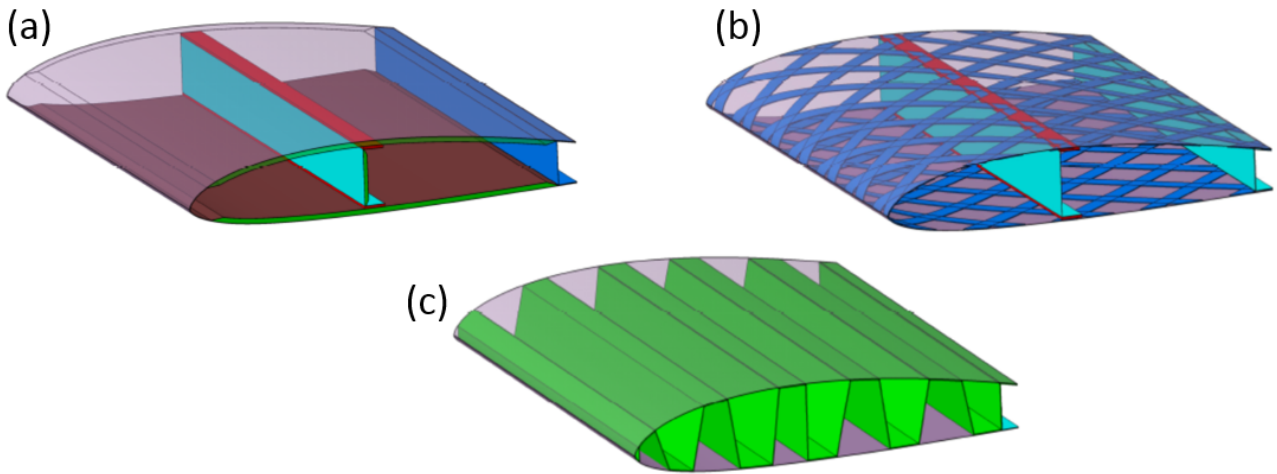

Figure 6: Architectures for an aircraft wing (a) standard sandwich box, (b) Geodesic structure, (c) Multi-web or corrugated integral sandwich structure (reproduced from [40])

- Fiber steering [71,72]
- 2.5D solutions: laminate with stitching or Z-Pinning [42,73–75]

The second most popular and historic solution is sandwich structures which are always a light and soft core with two strong faces. Sandwich structures can themselves be classified as symmetric and asymmetric, which have different uses in practice. Symmetric sandwiches are for bending or pressurized structures and asymmetric sandwiches may replace stiffened structures for very lightweight, non-pressurized parts of helicopters or drones [76,77]. As for laminates, there are, in fact, many solutions for the core and a non-exhaustive list is proposed here with some examples for reference:

- Foams, balsa, cork [78–84]
- Honeycomb and other shapes [76–81,85,86]
- Plywood [87,88]
- Entangled [89,90]
- Kagome, tetrahedral, pyramidal or other lattice cores [91–95]
- Corrugated [40,96,97]
- Folded [98,99]
- X-Cor [100]
- Hierarchical [99,101]
- Nap Core [102]
- And probably more...

In aeronautics or, more generally, for lightweight structures, stiffened structures have been widely used since the 1930s and the invention of the “monocoque” fuselage. The main categories are [39] [12] [103–105]:

- L or T stringers
- Omega stringers
- Isogrid or orthogrid
- PRSEUS

A renewal of geodesic structures, which were applied for the first time on the Wellington aeroplane during World War II [12] can be observed nowadays. In particular, the successful developments by Russian industry in this domain have been decisive for this renewal [106–109]. A short, non-exhaustive list of technologies is given here:

- Isogrid
- Lattice structure
- Isotruss

Other kinds of architectures exist, in particular to make thick parts:

- Forged carbon [110,111]
- 4D thermostructural composites [112]
- Textile preform [53,54] [38] [113–115]
 - Interlock [115]
 - Braids: tubular, 3D weaving [99,113,114,116,117]
 - Knitted fabrics [118]

Thus, the term "architecture" in this paper will refer to these macro-scale definitions and tentative classifications. For a given geometry, many architectures are possible but the inverse is rarely true. The choice of the architecture is also rather important as it determines the mechanical behaviour of the part (i.e. a sandwich structure takes advantage of a high bending stiffness compared to thin laminates), and it also drives the possible manufacturing routes.

2.4 Manufacturing processes

Here, too, the possibilities are numerous. However, the manufacturing processes are closely bound to the materials, the architecture, the way fibres are placed and the use of open or closed moulds. According to Astrom [119], manufacturing processes are mainly classified as thermoset-matrix techniques or thermoplastic-matrix techniques. For thermoset based composites, the following main families can be found [112] [120] [121]:

- Hand lay-up and autoclave
- ATL or AFP and autoclave
- Filament winding
- Out-of-autoclave processes:
 - Resin Transfer Molding
 - Liquid Resin Infusion
 - Resin Film Infusion

For thermoplastics, compression moulding on laminate preforms can be applied after a heating phase. Recently, ATL or filament winding has become possible with thermoplastic composites. To end, two other processes have to be taken into account: pultrusion and overmoulding. They are able to produce “net shaped” parts which are, of course, of great interest for industrial purposes. Other authors [120,122] use a different approach to classify these manufacturing processes. It depends on the main characteristic of the process: manual, compression, injection, continuous, and automated processes will be added to this list. Additive manufacturing is also under development, mainly for short-fibres composites [123] but it will not be considered here since it is still at a fairly early stage.

In order to highlight the influence of the manufacturing processes on the design process of a composite part, we propose tables to help during the analysis. The first three tables below (table 2, table 3, table 4) give the combinations between manufacturing processes and part geometry. The shape categories are taken from the shape classification presented in Fig. 4 and the processes are those most commonly used for manufacturing composite parts. Three symbols are used in the table to indicate whether the combination is used in normal practice, barely used (which could mean that the process is not perfectly suitable for the shape) or not applicable at all. References are also provided inside the tables; they give some examples or applications to which the reader can refer.

The second part of the analysis concerns the relationship between the architecture and the manufacturing processes (table 5). The third part is the relationship between the reinforcements and the manufacturing processes (table 6). The different types of reinforcement that exist in the market cannot be used with every manufacturing process. This table gives an idea of the possibilities available for each process. The choice of the

		Prismatic Shapes							
		Solid				Hollow			
		Circular		Non-circular		Circular		Non-circular	
		Plain	Stepped	Plain	Stepped	Plain	Stepped	Plain	Stepped
Manual Processes									
	Hand Lay-up	x	x	–	–	–	–	–	–
	Spray-up	x	x	x	x	x	x	x	x
Compression-based processes									
	Thermoplastic Stamping	x	x	x	x	x	x	x	x
	Compression Moulding	x	x	x	x	x	x	x	x
Injection processes									
	Reinforced Thermoplastics	x	x	●	●	●	●	–	–
	Resin Injection Moulding	x	x	●	●	●	●	–	–
	Resin Transfer Moulding	x	x	●	●	● [124]	● [124]	–	–
Continuous processes									
	Pultrusion	●	x	●	x	●	x	●	x
	Filament Winding	x	x	x	x	●	●	●	●
	Pullwinding	●	x	●	x	●	x	●	x
Automated processes									
	Automated Tape Laying	x	x	x	x	x	x	x	x
	Automated Fibre Placement	x	x	x	x	x	x	x	x

●: Normal practice –: Less-common practice x: Not applicable

Table 2: Processes vs Prismatic Shape

		Thin-Walled Shapes							
		Curved					Flat		
		Axisymmetric			Non-axisymmetric			No cutouts	Cutouts
		Shallow	Deep	Re-entrant	Shallow	Deep	Re-entrant		
Manual Processes									
	Hand Lay-up	●	●	x	● [125]	● [125]	x	● [125, 126]	●
	Spray-up	●	●	x	●	●	x	● [127, 128]	●
Compression-based processes									
	Thermoplastic Stamping	● [129]	–	x	● [129]	– [130]	x	● [129]	–
	Compression Moulding	●	–	x	●	–	x	●	–
Injection processes									
	Reinforced Thermoplastics	●	–	x	●	–	x	●	●
	Resin Injection Moulding	●	–	x	●	–	x	●	●
	Resin Transfer Moulding	●	–	x	●	–	x	●	●
Continuous processes									
	Pultrusion	x	x	x	x	x	x	x	x
	Filament Winding	x	x	x	x	x	x	x	x
	Pullwinding	x	x	x	x	x	x	x	x
Automated processes									
	Automated Tape Laying	●	●	x	● [131]	–	x	● [131]	●
	Automated Fibre Placement	● [132]	●	x	● [133]	–	x	● [133]	●

●: Normal practice –: Less-common practice x: Not applicable

Table 3: Processes vs Thin-Walled Shape

reinforcement has to be governed by the mechanical strength desired, on the one hand, and by the manufacturing process used on the other.

These tables are neither exhaustive nor definitive in this article and are likely to be improved in later publications. They are presented here as an illustration of the GAP methodology proposed in the present article. They can be used in two configurations in the methodology: if there is a manufacturing constraint, they can help with the choice of the geometry during the creative phase, and, they can be used as a tool for selecting geometries during the screening phase (more details about this phase are given in Part 3). Finally, it should

		Bulk Shapes							
		Parallel Features				Transverse Features			
		Solid		Hollow		Solid		Hollow	
		Simple	Complex	Simple	Complex	Simple	Complex	Simple	Complex
Manual Processes									
	Hand Lay-up	x	x	–	–	–	–	–	–
	Spray-up	x	x	x	x	x	x	x	x
Compression-based processes									
	Thermoplastic Stamping	x	x	x	x	x	x	x	x
	Compression Moulding	x	x	x	x	x	x	x	x
Injection processes									
	Reinforced Thermoplastics	●	–	x	x	●	–	x	x
	Resin Injection Moulding	●	–	x	x	●	–	x	x
	Resin Transfer Moulding	● ^[134]	–	x	x	●	–	x	x
Continuous processes									
	Pultrusion	● ^[135]	x	● ^[135]	x	●	x	●	x
	Filament Winding	x	x	x	x	●	●	x	x
	Pullwinding	●	x	●	x	x	x	x	x
Automated processes									
	Automated Tape Laying	x	x	x	x	x	x	x	x
	Automated Fibre Placement	x	x	x	x	x	x	x	x
●: Normal practice		–: Less-common practice			x: Not applicable				

Table 4: Processes vs Bulk Shape

		Architectures						
		Thin laminate	Thick laminate	Sandwich	Tube	Geodesic	Overmolded	3D
Manual Processes								
	Hand Lay-up	● ^[125,126]	–	● ^[136]	x	x	x	x
	Spray-up	● ^[127,128]	–	x	x	x	x	x
Compression-based processes								
	Thermoplastic Stamping	● ^[129]	x	– ^[137]	x	x	● ^[138]	x
	Compression Moulding	x	x	– ^[136]	x	x	x	x
Injection processes								
	Reinforced Thermoplastics	●	–	– ^[137]	● ^[135]	x	● ^[138]	– ^[135]
	Resin Injection Moulding	●	● ^[132]	● ^[136,137]	x	x	x	●
	Resin Transfer Moulding	●	● ^[134]	● ^[137]	● ^[135]	x	x	● ^[135]
Continuous processes								
	Pultrusion	●	●	– ^[139]	● ^[135]	x	x	● ^[135]
	Filament Winding	x	x	x	● ^[135]	● ^[140]	x	x
	Pullwinding	x	x	x	● ^[135]	x	x	x
Automated processes								
	Automated Tape Laying	● ^[131]	–	x	x	x	x	x
	Automated Fibre Placement	● ^[132,133]	–	x	x	x	x	x
●: Normal practice		–: Less-common practice			x: Not applicable			

Table 5: Processes vs Architectures

be noted that other solutions exist. For example, some manufacturing processes can be combined and adapted directly to the manufacturing process of one part, as is the case for the frames manufactured by Airbus [142].

2.5 Summary

In this section, we propose to tackle the complex problem of the design of a composite part following three main axes of development: the shape, the manufacturing process and the architecture of the structure. The GAP methodology can thus be represented simply by the diagram shown in Fig. 7. Some of the interdependencies between these axes were underscored previously but not in an exhaustive way. The complex issue concerning the choice of materials is intentionally not included in our thinking because this has already been addressed in the literature. Moreover, it can also be considered as too constraining during the creativity process and this

	Reinforcements							
	Mat	Short fibers	UD	Fabric	Pre-preg	Non-crimp fabric	3D braiding	3D weaving
Manual Processes								
Hand Lay-up	● [126]	● [126]	–	● [125]	● [125]	x	x	x
Spray-up	● [127]	● [127]	x	x	x	x	x	x
Compression-based processes								
Thermoplastic Stamping	x	x	● [129]	● [129, 130]	x	x	x	x
Compression Moulding	●	●	●	●	●	x	x	x
Injection processes								
Reinforced Thermoplastics	●	●	●	●	●	x	● [135]	–
Resin Injection Moulding	x	x	●	●	●	● [128]	–	–
Resin Transfer Moulding	x	– [124]	● [134]	● [134]	– [141]	● [134]	● [135]	–
Continuous processes								
Pultrusion	●	●	–	x	●	x	● [135]	x
Filament Winding	x	x	–	x	●	x	x	x
Pullwinding	x	x	–	x	●	x	x	x
Automated processes								
Automated Tape Laying	●	●	–	x	– [131]	x	x	x
Automated Fibre Placement	●	●	x	x	– [132]	x	x	x

●: Normal practice –: Less-common practice x: Not applicable

Table 6: Processes vs Reinforcements

choice should ultimately be made according to the industrial context and the mechanical constraints of the product. In the following section, the GAP methodology is explained and illustrated by two examples.

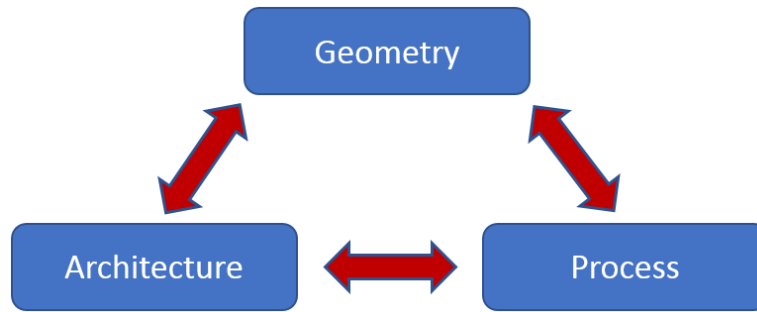

Figure 7: GAP methodology structure

3 The GAP methodology

3.1 The scope of the methodology

The GAP methodology defines a way to create of innovative composite material based solutions. As stated in the previous sections, to face the dilemma (Fig. 3) of the design or re-design of a part or a complete mechanical subassembly, a resolution scheme is proposed and includes the three axes: Geometry, Architecture and Process. One of the direct consequences of this approach is that thinking first about the geometry gives more freedom for creativity to generate as many solutions as possible. We thus suggest the following methodology (Fig. 8):

- Create innovative solutions by thinking about geometry first
- These solutions can be imagined according to three possible configurations:
 - No constraints at all: free design
 - Architecture constraints: for example, laminates or sandwiches required
 - Manufacturing objectives: for example, "one shot" parts

Once these solutions have been created, a more classic design procedure must be performed to make a go/no go decision on each design. This can be based, among other things, on Figure of Merit, Key Performance parameters [39] [143], material selection procedure [14] [15–24], manufacturing process selection, sizing, or cost evaluation depending on the industrial context. Thus, the GAP methodology is part of the conceptual and preliminary design as defined in the design flow by Ashby [14] shown in Fig. 9. At this stage of the project, the idea is to imagine as many concepts as possible in the conceptual part in order to obtain a short list of concepts at the end of the preliminary phase.

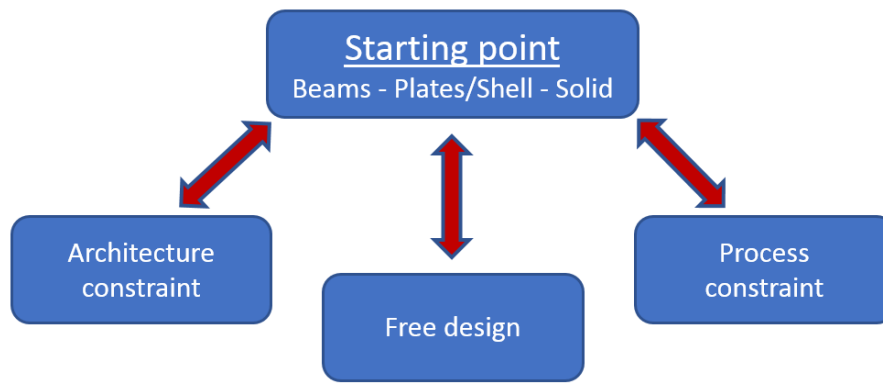

Figure 8: GAP methodology

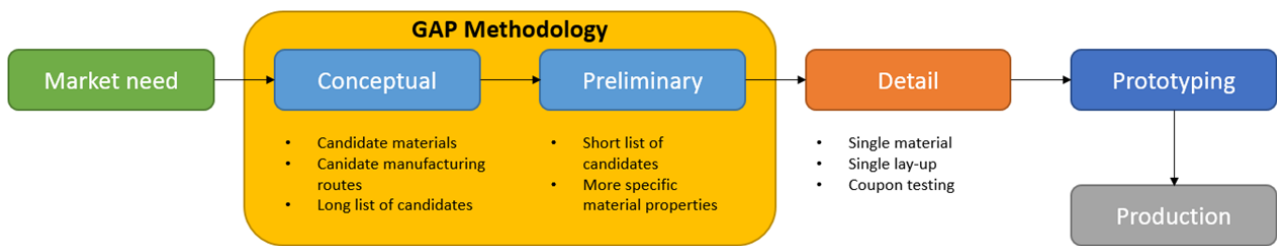

Figure 9: Integration of the GAP methodology in the design flow for a generic project [14]

3.2 Case studies

Two purely academic examples are proposed in this section. The GAP methodology was tested on bachelor's degree students of INSA Toulouse who had a very limited knowledge of composite materials (10 hours of courses).

Case study 1: Economy seat

The subject was: "Make a composite solution for an economy class seat of a short range aircraft. It is attached to the floor by four point links located at the centre of the structure. Use the GAP methodology then propose three solutions based on plate or shell shapes and three others based on beam shapes. For dimensions, use the dimensions of your own chair. Then explain how to manufacture your solution."

A selection of the solutions imagined by the students is shown in Fig. 10 to Fig. 13 and illustrates the wide variety of design solutions proposed that are a good starting point for such a project.

For the beam-based concepts, the students proposed two kinds of solutions with various geometries: solutions composed of simple composite beams joined together (Fig. 10 a to f) and solutions using more complex beams in order to reduce the number of parts (Fig. 10 g to m), even going as far as a one shot solution (Fig. 10 k).

For the shell-based and plate-based concepts, there were more possibilities (Fig. 11 and Fig. 12). For each solution, there were several ways of manufacturing the seat: assemblies, one shot injection, folding of thermoplastic plates, etc. After designing the first concepts, each solution should be analysed considering the manufacturing processes suitable in an industrial context. It can also be noted that, at that step of the methodology, some solutions could be realized with either laminates or sandwich structures. Multi-material solutions could also be considered...

As for case study number 2, these solutions have to be screened with particular parameters belonging to each industrial context.

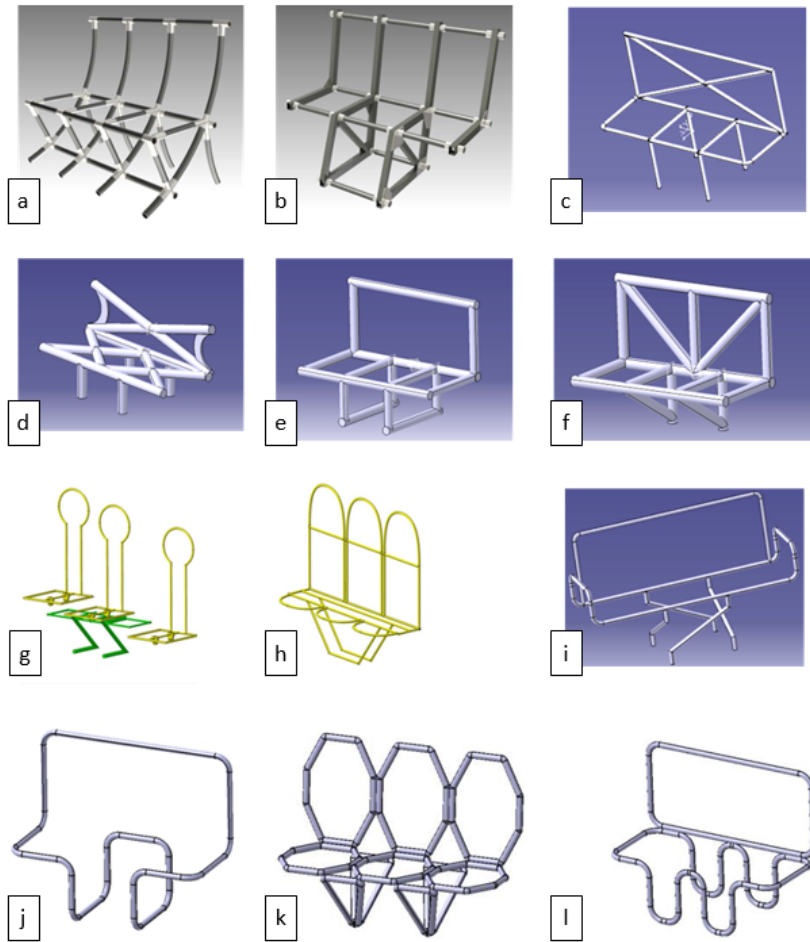

Figure 10: Beam-based solutions for an economy seat

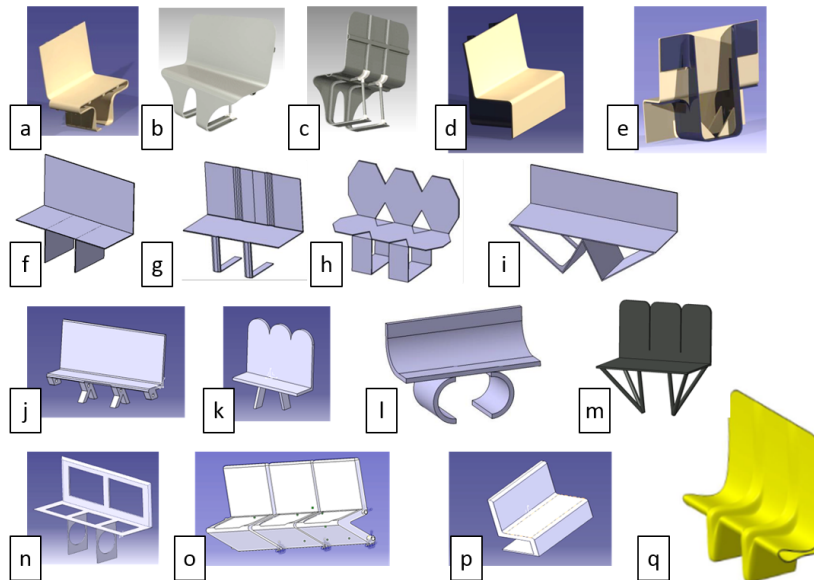

Figure 11: Shell and plate-based solutions for an economy seat

Case study 2: Composite support

The subject was: “Make a composite solution for a support. Use the GAP methodology and propose solutions based on plate or shell shapes and others based on beam shapes. Then explain how to manufacture your solution.” The functional surfaces for this case study are shown in Fig. 14. In order to give an idea of the size of the composite part to be designed, we specify that the dimensions between the corners are 700x400 mm. A selection of the solutions imagined by the students is presented in Fig. 15 to Fig. 17 and shows the wide variety

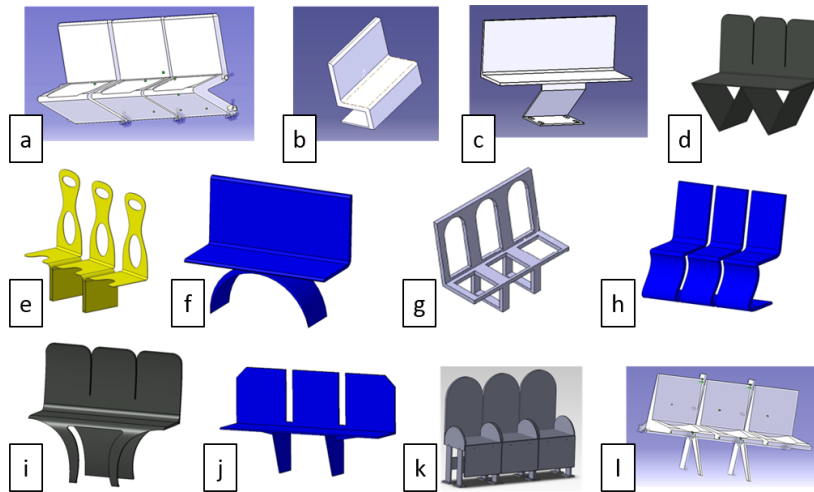

Figure 12: Shell and plate-based solutions for an economy seat

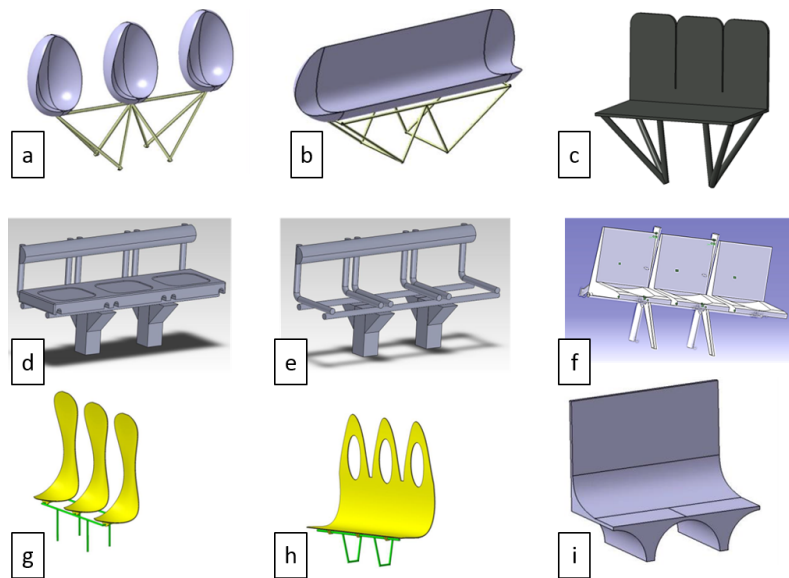

Figure 13: Mixed solutions beam/shell/solid for an economy seat

of solutions proposed that are a good starting point for such a project. These solutions were then screened with the constraints of manufacturing cost for a medium series.

Unlike the situation in case study 1, the geometry is constrained by the imposed functional surfaces here. This adds difficulties for the designer but such situations are common in the industry. The rules for designing the structure are simple: the geometry must necessarily coincide with the functional surfaces and the design space falls within the limits set by these surfaces. Otherwise, the design remains free and all kinds of shapes can be imagined to join these surfaces. There is no limit on the number of components, i.e. the structure could be imagined in one shot manufacturing or by assembling several parts. Among the beam-based solutions (Fig. 15), some may appear too fragile (Fig. 15 a, e, f and j) and reinforcements might be needed. The solution in Fig. 15-g appears to be too complex and should be discarded. In contrast, plate and shell-based solutions (Fig. 16) or mixed concepts (Fig. 17) look simpler to manufacture. The generation of the first concepts must not impose limits on the manufacturing possibilities, the next screening step will determine and eliminate the geometries considered as too costly to manufacture.

An overview of the concepts created in the first instance is given in Fig. 15 to Fig. 17. It is interesting to note the diversity of architectures and approaches encompassed by the three families of forms defined above. The majority of the solutions tend to use shells, which is understandable as composite structures are mainly oriented towards these forms. Given the large choice of architecture and processes available for composite materials, having a clear vision of the possibilities of manufacturing at this early stage is a great asset for pre-concepts. At this point, the GAP methodology suggests reviewing every pre-concept imagined and screening with the help of important criteria relative to the composite part. Criteria could be anything from the manufacturing

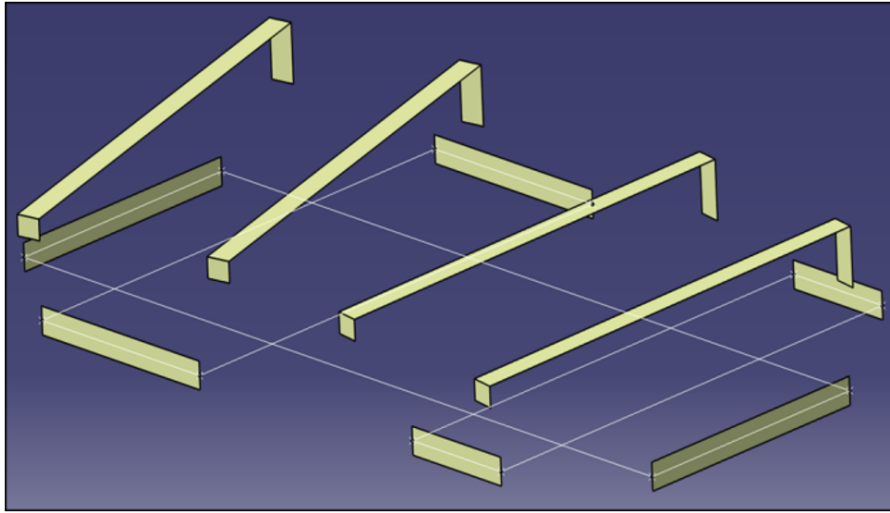

Figure 14: Functional surfaces for the support

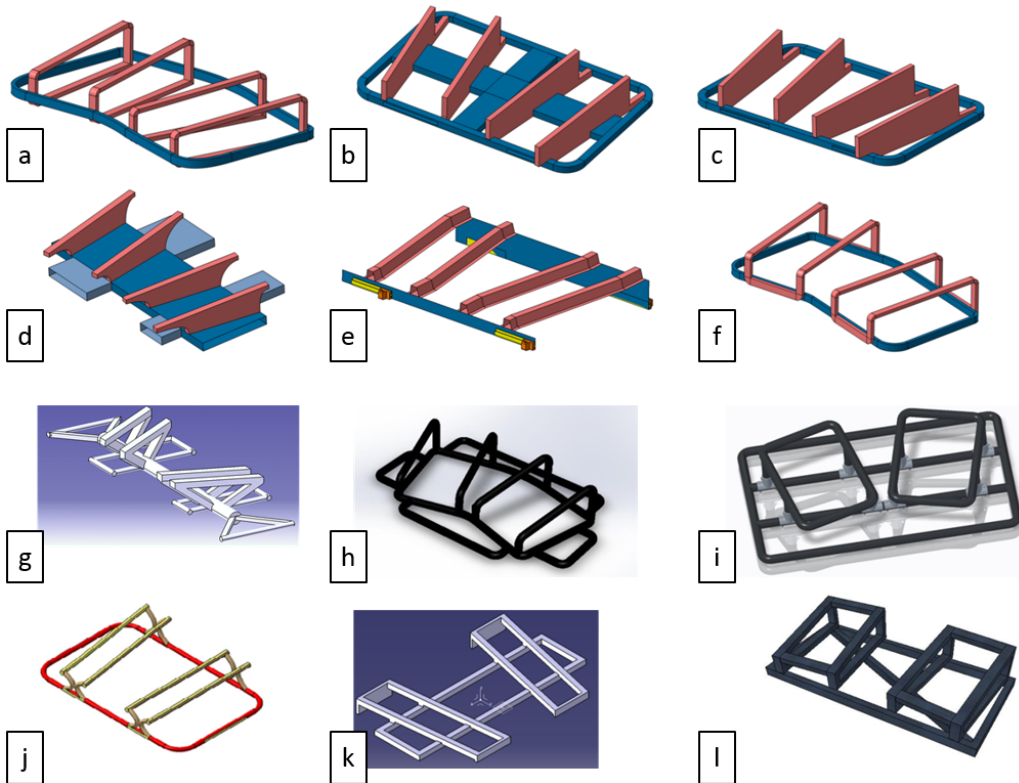

Figure 15: Beam solutions for a composite support

cost to the mass, the structure resistance, the technological difficulties etc. As pre-concepts are rather sketchily detailed geometries, one criterion should be based on the technological difficulties that may arise later in the manufacture of the part. In one of the solutions proposed here, there may be a bonding issue between the omega-shaped beams and the support that has not been considered. The designer's experience is of great value here to judge whether the concepts have good potential. In cases where the concepts are not mature enough to properly indicate the selection criteria, other design iterations can be considered to facilitate this screening step. At the end of that phase, a short list of solutions should be given. The concepts chosen are obviously those that obtain the best score and two or three concepts should be enough to continue. Iterative design loops must then be carried out along with numerical simulations to validate the geometry and find the best stacking and thickness for the part.

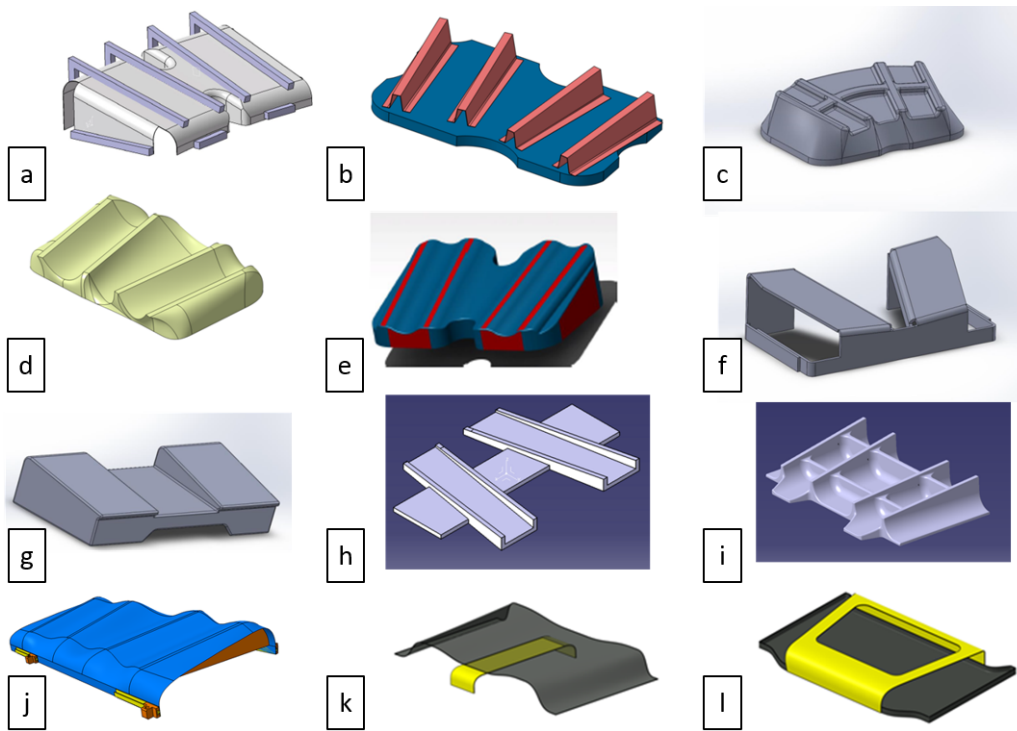

Figure 16: Shell and plate-based solutions for a composite support

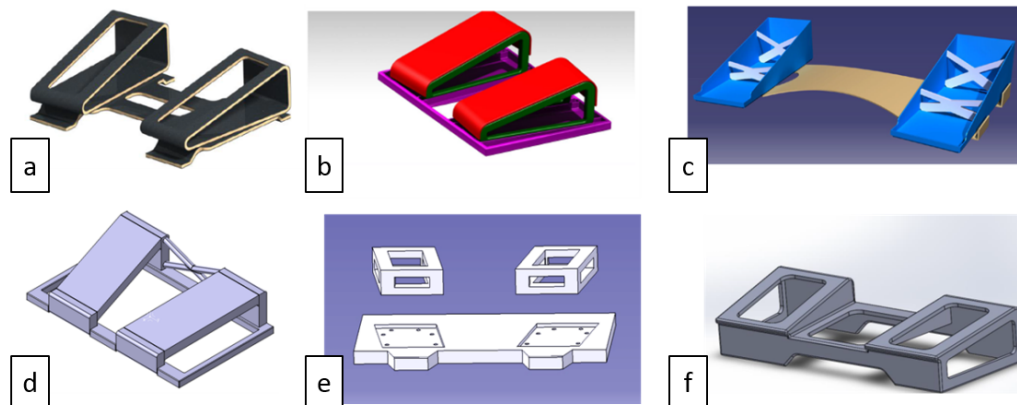

Figure 17: Mixed beam/shell/solid solutions for a composite support

4 Conclusion

The task of designing composite parts is made challenging by the complexity of the materials and the large number of decisions that have to be taken throughout the project. The GAP methodology provides a solution to help the right decisions to be taken during the early pre-concept phase by enabling the emergence of numerous solutions. Considering this step as one of the most important, since bad decisions at this stage could lead to a mediocre final result, the GAP methodology provides tools to perform a rapid analysis of the first concepts by integrating the three main sets of problems impacting the design of composite structures. The methodology relies heavily on imagination and creativity for the design part. It also relies on a specific analysis of each concept giving enough information to select the most valuable concepts that will be developed more precisely later on. Early decisions that have to be taken are decisive for any project. Bad decisions at this point imply a waste of time and money that could become critical at some point. The GAP methodology is a solution for reducing the risks of poor decisions when it comes to designing - or re-designing - a mechanical product in composite materials.

5 Acknowledgements

The authors acknowledge Bpifrance Financement for its financial support in the FUI contract N°F1504022M.

References

- [1] J. Fan and J. Njuguna, "An introduction to lightweight composite materials and their use in transport structures," in *Lightweight Composite Structures in Transport* (J. Njuguna, ed.), ch. 1, pp. 3–34, Woodhead Publishing, 2016.
- [2] Brochure Aérospatiale, *Matériaux composites : dans la grande mutation des structures*. DCT 1135, 01/04/1986.
- [3] M. Carello, A. G. Airale, A. Ferraris, A. Messana, and L. Sisca, "Static Design and Finite Element Analysis of Innovative CFRP Transverse Leaf Spring," *Applied Composite Materials*, vol. 24, pp. 1493–1508, Dec. 2017.
- [4] Elixir Aircraft. <http://elixir-aircraft.com/en/>. Accessed: 2018-12-13.
- [5] S. W. Tsai and J. M. Patterson, "Simplified Design of Composite Materials," *Materials and Design*, vol. 8, May-June 1987.
- [6] L. Wang, A. Kolios, T. Nishino, P.-L. Delafin, and T. Bird, "Structural optimisation of vertical-axis wind turbine composite blades based on finite element analysis and genetic algorithm," *Composite Structures*, vol. 153, pp. 123–138, 2016.
- [7] S. R. Henrichse, E. Lindgaard, and E. Lund, "Free material stiffness design of laminated composite structures using commercial finite element analysis codes," *Structural and Multidisciplinary Optimization*, 2015.
- [8] J. L. Galos and M. Sutcliffe, "Development of a structural optimisation methodology for use in the design of a composite semi-trailer chassis," *21st International Conference on Composite Materials Xi'An*, Aug. 2017.
- [9] F. Léné, G. Duvaut, M. Olivier-Mailhé, M. Ben Chaabane, and S. Grihon, "An advanced methodology for optimum design of a composite stiffened cylinder," *Composite Structures*, vol. 91, pp. 392–397, 2009.
- [10] J. Lee, D. Lee, J. Park, I. Choi, J. W. Lim, S. Kim, and D. G. Lee, "Carbon/epoxy composite foot structure for biped robots," *Composite Structures*, vol. 140, pp. 344–350, June 2016.
- [11] P. V. Vijay, P. R. Soti, H. V. S. GangaRao, R. G. Lampo, and J. D. Clarkson, "Design and evaluation of an integrated FRP composite wicket gate," *Composite Structures*, vol. 145, pp. 149–161, June 2016.
- [12] D. Paul and D. Pratt, "History of Flight Vehicle Structures 1903-1990," *Journal of Aircraft*, vol. 41, pp. 969–977, Sep-Oct 2004.
- [13] P. Feraboli, A. Masini, L. Taraborrelli, and A. Pivetti, "Integrated development of CFRP structures for a topless high performance vehicle," *Composite Structures*, vol. 78, pp. 495–506, 2007.
- [14] M. Ashby and K. Johnson, *Materials and design: the art and science of material selection in product design*. Oxford: Butterworth-Heinemann, 2002.
- [15] M. Noryani, S. M. Sapuan, M. T. Mastura, M. T. Zuhri, and E. S. Zainudin, "Material selection criteria for natural fibre composite in automotive component: a review," *IOP Conference Series: Materials Science and Engineering*, vol. 368, no. 1, 2018.
- [16] D. Zindani, S. R. Maity, and S. Bhowmik, "A decision-making approach for material selection of polymeric composite bumper beam," *Composite and Advanced Materials for Industrial Applications*, pp. 112–128, 2018.
- [17] Y. Swolfs, I. Verpoest, and L. Gorbatikh, "Recent advances in fibre-hybrid composites: materials selection, opportunities and applications," *International Materials Reviews*, pp. 1–35, 2018.
- [18] S. Kazemzadeh Azad and T. Akiş, "Automated selection of optimal material for pressurized multilayer composite tubes based on an evolutionary approach," *Neural Computing and Applications*, vol. 29, no. 7, pp. 405–416, 2018.
- [19] M. Noryani, S. M. Sapuan, and M. T. Mastura, "Multi-criteria decision-making tools for material selection of natural fibre composites: a review," *Journal of Mechanical Engineering and Sciences*, vol. 12, no. 1, pp. 3330–3353, 2018.

- [20] H. Wargnier, F. X. Kromma, M. Danis, and Y. Brechet, "Proposal for a multi-material design procedure," *Materials and Design*, vol. 56, pp. 44–49, 2014.
- [21] O. T. Thomsen, "Sandwich Materials for Wind Turbine Blades: Present and Future," *Journal of Sandwich Structures and Materials*, vol. 7, no. 11, 2009.
- [22] J. Pflug and I. Verpoest, "Sandwich Materials Selection Charts," *Journal of Sandwich Structures and Materials*, vol. 8, no. 407, 2006.
- [23] C. Monroy Aceves, A. A. Skordos, and M. P. F. Sutcliffe, "Design selection methodology for composite structures," *Materials and Design*, vol. 29, pp. 418–426, 2008.
- [24] C. Monroy Aceves, M. P. F. Sutcliffe, M. F. Ashby, A. A. Skordos, and C. Rodríguez Román, "Design methodology for composite structures: A small low air-speed wind turbine blade case study," *Materials and Design*, vol. 36, pp. 296–305, 2012.
- [25] A. Hambali, S. M. Sapuan, N. Ismail, and Y. Nukman, "Composite manufacturing process selection using analytical hierarchy process," *International Journal of Mechanical and Materials Engineering (IJMME)*, vol. 4, no. 1, pp. 49–61, 2009.
- [26] M. G. Bader, "Selection of composite materials and manufacturing routes for cost-effective performance," *Composites: Part A*, vol. 33, pp. 913–934, 2002.
- [27] S. Howard, T. Culley and E. Dekoninck, "Creativity in the engineering design process," *International Conference on Engineering Design*, Aug. 2007.
- [28] S. Howard, T. Culley and E. Dekoninck, "Describing the creative design process by the integration of engineering design and cognitive psychology literature," *Design Studies*, no. 29, pp. 160–180, 2008.
- [29] S. Niemann and al, "The use of topology optimisation in the conceptual design of next generation lattice composite aircraft fuselage structures," *Aeronautical Journal*, vol. 117, Nov. 2013.
- [30] C. Wilson, *Brainstorming and beyond: A User-Centered Design Method*. Morgan Kaufmann, 2013.
- [31] M. S. Aziz and A. Y. El Sheriff, "Biomimicry as an approach for bio-inspired structure with the aid of computation," *Alexandria Engineering Journal*, no. 55, pp. 704–717, 2016.
- [32] J. Lu, "The Conflict Resolution in Product Experience Design Based on Evaporating Cloud of the Theory of Constraints," *Lecture Notes in Computer Science*, no. 9186, pp. 53–62, 2015.
- [33] L. Chechurin and Y. Borgianni, "Understanding TRIZ through the review of top cited publications," *Computers in Industry*, no. 82, pp. 119–134, 2016.
- [34] D. Ullman, *The mechanical Design Process Fourth Edition*. McGraw-Hill, 2010.
- [35] CES EduPack. http://www.grantadesign.com/education/InDepth/html/indepth/shapeinfo/shape_classification.htm. Accessed: 2018-12-13.
- [36] K. Zimmermann, D. Zenkert, and M. Siemetzki, "Testing and analysis of ultra-thick composites," *Composites Part B: Engineering*, vol. 41, pp. 326–336, June 2010.
- [37] M. Siemetzki, K. Zimmermann, and P. Middendorf, "Ultra-thick laminates chances and limitations," *17th International Conference on Composite Materials, Edinburgh, UK*, 2009.
- [38] A. P. Mouritz, M. K. Bannister, P. J. Falzon, and K. H. Leong, "Review of applications for advanced three-dimensional fibre textile composites," *Composites: Part A*, vol. 30, pp. 1445–1461, 1999.
- [39] T. M. Krivanek and B. C. Yount, "Composite payload fairing structural architecture assessment and selection," *SAMPE Conference, Baltimore, MD, USA*, May 2012.
- [40] T. Urik and M. Mališ, "Innovative composite structures for small aircraft," *26th International Congress of the Aeronautical Sciences, Anchorage, Alaska, USA*, Sept. 2008.
- [41] C. Soutis, "Fibre reinforced composites in aircraft construction," *Progress in Aerospace Sciences*, vol. 41, pp. 143–151, 2005.
- [42] A. Njionhou, F. Berthet, B. Castanié, and C. Bouvet, "Relationships between LRI process parameters and impact and post-impact behaviour of stitched and unstitched NCF laminates," *Applied Composite Materials*, vol. 19, pp. 885–899, 2012.

- [43] L. Gigliotti and S. T. Pinho, “Translaminar fracture toughness of NCF composites with multiaxial blankets,” *Materials and Design*, vol. 94, pp. 410–416, March 2016.
- [44] A. Shipsha, M. Burman, and J. Ekh, “Failure of cross-ply NCF composites under off-axis compressive loads - An experimental study and a new strength prediction model including fibre bundle waviness,” *Composites Part B: Engineering*, vol. 153, pp. 49–56, Nov. 2018.
- [45] A. Njionhou, F. Berthet, and B. Castanié, “Effects of process parameters on the mechanical properties and morphology of stitched and non-stitched carbon/epoxy liquid resin-infused NCF laminate, out of autoclave and out of oven,” *International Journal of Advanced Manufacturing Technology*, vol. 65, pp. 1289–1302, 2013.
- [46] D. Wilhelmsson, R. Gutkin, F. Edgren, and L. E. Asp, “An experimental study of fibre waviness and its effects on compressive properties of unidirectional NCF composites,” *Composites Part A: Applied Science and Manufacturing*, vol. 107, pp. 665–674, Feb. 2018.
- [47] R. Amacher, J. Cugnoni, J. Botsis, L. Sorensen, and C. Smith, W. Dransfeld, “Thin ply composites: Experimental characterization and modeling of size-effects,” *Composites Science and Technology*, vol. 101, pp. 121–132, 2014.
- [48] A. Arteiro, G. Catalanotti, J. Xavier, P. Linde, and P. P. Camanho, “A strategy to improve the structural performance of non-crimp fabric thin-ply laminates,” *Composite Structures*, vol. 188, pp. 438–449, 2018.
- [49] J. D. Fuller and M. R. Wisnom, “Pseudo-ductility and damage suppression in thin ply CFRP angle-ply laminates,” *Composites Part A: Applied Science and Manufacturing*, vol. 69, pp. 64–71, 2015.
- [50] A. Arteiro, G. Catalanotti, J. Xavier, and P. P. Camanho, “Notched response of non-crimp fabric thin-ply laminates,” *Composites Science and Technology*, vol. 79, pp. 97–114, 2013.
- [51] G. Bullegas, S. T. Pinho, and S. Pimenta, “Engineering the translaminar fracture behaviour of thin-ply composites,” *Composites Science and Technology*, vol. 131, pp. 110–122, 2016.
- [52] S. Sihm, R. Y. Kim, K. Kawabe, and S. W. Tsai, “Experimental studies of thin-ply laminated composites,” *Composites Science and Technology*, vol. 67(6), pp. 996–1008, May 2007.
- [53] R. Kamiya, B. A. Cheeseman, P. Popper, and T.-W. Chou, “Some recent advances in the fabrication and design of three-dimensional textile preforms: a review,” *Composites Science and Technology*, vol. 60, pp. 33–47, 2000.
- [54] S. Rana and R. Figueiro, *BRAIDED STRUCTURES and COMPOSITES Production, Properties, Mechanics and Technical applications*. CRC Press, 2016.
- [55] A. Malpot, F. Touchard, and S. Bergamo, “Influence of moisture on the fatigue behaviour of a woven thermoplastic composite used for automotive application,” *Materials and Design*, vol. 98, pp. 12–19, May 2016.
- [56] B. Vieille, V. M. Casado, and C. Bouvet, “Influence of matrix toughness and ductility on the compression-after-impact behavior of woven-ply thermoplastic and thermosetting composites : a comparative study,” *Composite Structures*, vol. 110, pp. 207–218, 2014.
- [57] A. Rashidi and A. S. Milani, “A multi-step biaxial bias extension test for wrinkling/de-wrinkling characterization of woven fabrics: Towards optimum forming design guidelines,” *Materials and Design*, vol. 146, pp. 273–285, May 2018.
- [58] F. Gamdani and A. Boukhili, R. ad Vadean, “Tensile strength of open-hole, pin-loaded and multi-bolted single-lap joints in woven composite plates,” *Materials and Design*, vol. 88, pp. 702–712, Dec. 2015.
- [59] F. Pascal, A. Rogani, B. Mahmoud, P. Navarro, S. Marguet, and J.-F. Ferrero, “Impact damage prediction in thin woven composite laminates - Part II: Application to normal and oblique impacts on sandwich structure,” *Composite Structures*, vol. 190, pp. 43–51, Apr. 2018.
- [60] F. Pascal, O. Dorival, P. Navarro, S. Marguet, and J.-F. Ferrero, “Impact damage prediction in thin woven composite laminates - Part I: Modeling strategy and validation,” *Composite Structures*, vol. 190, pp. 32–42, Apr. 2018.
- [61] Z. M. Huang, “The mechanical properties of composites reinforced with woven and braided farics,” *Composites Science and Technology*, vol. 60(4), pp. 479–498, 2000.

- [62] C. Wang, A. Roy, Z. Chen, and V. V. Silberschmidt, “Braided textile composites for sports protection: Energy absorption and delamination in impact modelling,” *Materials and Design*, vol. 136, pp. 258–269, Dec. 2017.
- [63] O. Zebdi, R. Boukhili, and F. Trochu, “An inverse approach based on laminate theory to calculate the mechanical properties of braided composites,” *Journal of Reinforced Plastics and Composites*, vol. 28(23), pp. 2911–2930, 2009.
- [64] C. Zhao, Y. Huang, Z. Chen, and S. K. Ha, “Progressive failure prediction of a landing gear structure of braided composites,” *Composite Structures*, vol. 161, pp. 407–418, 2017.
- [65] P. L. Dewalt and R. P. Reichard, “Just How Good are Knitted Fabric,” *Journal of Reinforced Plastics and Composites*, vol. 13(10), pp. 908–917, 1994.
- [66] D. H. Benson and G. H. Hasko, “Mechanical properties and damage tolerance of multiaxial warp-knit composites,” *Composites Science and Technology*, vol. 56(3), pp. 367–380, 1996.
- [67] T. Sinmazçelik, E. Avcu, M. O. Bora, and C. Çoban, “A review: Fibre metal laminates, background, bonding types and applied test methods,” *Materials and Design*, vol. 32, pp. 3671–3685, Aug. 2011.
- [68] A. Asundi and A. Y. N. Choi, “Fiber metal laminates: An advanced material for future aircraft,” *Journal of Materials Processing Technology*, vol. 63, pp. 384–394, 1997.
- [69] S. Christke, A. G. Gibson, K. Grigoriou, and A. P. Mouritz, “Multi-layer polymer metal laminates for the fire protection of lightweight structures,” *Materials and Design*, vol. 97, pp. 349–356, May 2016.
- [70] K. Giasin, S. Ayvar-Soberanis, and A. Hodzic, “The effects of minimum quantity lubrication and cryogenic liquid nitrogen cooling on drilled hole quality in GLARE fibre metal laminate,” *Materials and Design*, vol. 89, pp. 996–1006, Jan. 2016.
- [71] C. Lopes, P. Camanho, Z. Gürdal, and B. Tatting, “Progressive failure analysis of tow-placed, variable-stiffness composite panels,” *International Journal of Solids and Structures*, vol. 44, pp. 8493–8516, Dec. 2007.
- [72] R. Li, D. Kelly, and A. Crosky, “Strength improvement by fibre steering around a pin loaded hole,” *Composite Structures*, vol. 57, pp. 377–383, July 2002.
- [73] J. Toral, B. Castanié, J.-J. Barrau, and N. Swiergel, “Multi-level analysis of low-cost Z-pinned composite joints; Part 2: Joint behaviour,” *Composites Part A: Applied Science and Manufacturing*, vol. 42, pp. 2082–2092, 2011.
- [74] J. Toral, B. Castanié, J.-J. Barrau, and N. Swiergel, “Multi-level analysis of low-cost Z-pinned composite joints; Part 2: Single Z-pin behaviour,” *Composites Part A: Applied Science and Manufacturing*, vol. 42, pp. 2070–2081, 2011.
- [75] I. Gnaba, X. Legrand, P. Wang, and D. Soulat, “Through-the-thickness reinforcement for composite structures: A review,” *Journal of industrial textiles*, 2018.
- [76] B. Castanié, J.-J. Barrau, J.-P. Jaouen, and S. Rivallant, “Combined shear/compression structural testing of asymmetric sandwich structures,” *Experimental Mechanics*, vol. 44, pp. 461–472, 2004.
- [77] B. Castanié, J.-J. Barrau, and J.-P. Jaouen, “Theoretical and experimental analysis of asymmetric sandwich structures,” *Composite Structures*, vol. 55, pp. 295–306, 2002.
- [78] L. L. Gibson and M. F. Ashby, *Cellular Solids, Structure and Properties*. Cambridge University Press, 1999.
- [79] D. Zenkers, *An introduction to Sandwich Construction*. E-MAS Publishing, 1995.
- [80] J. R. Vinson, *The Behavior of Sandwich Structures of Isotropic and Composite Materials*. CRC Press, 1999.
- [81] S. Abrate, B. Castanié, and Y. D. S. Rajapakse, *Dynamic failure of composite sandwich structures*. Springer, 2012.
- [82] I. M. Daniel, E. E. Gdoutos, and Y. D. S. Rajapakse, *Major Accomplishments in Composite Materials and Sandwich Structures: An Anthology of ONR Sponsored Research*. Springer, 2009.

- [83] H. Wang, K. S. Ramakrishnan, and K. Shankar, “Experimental study of the medium velocity impact response of sandwich panels with different cores,” *Materials and Design*, vol. 99, pp. 68–82, June 2016.
- [84] Y. Zhang, Z. Zong, Q. Liu, J. Ma, Y. Wu, and Q. Li, “Static and dynamic crushing responses of CFRP sandwich panels filled with different reinforced materials,” *Materials and Design*, vol. 117, pp. 396–408, March 2017.
- [85] D. Zhang, G. Lu, D. Ruan, Q. Fei, and W. Duan, “Quasi-static combined compression-shear crushing of honeycombs: An experimental study,” *Materials and Design*, vol. 167, April 2019.
- [86] Y. Aminanda, B. Castanié, J.-J. Barrau, and P. Thevenet, “Experimental analysis and modeling of the crushing of honeycomb cores,” *Applied Composite Materials*, vol. 12(3-4), pp. 213–227, May 2005.
- [87] J. P. Susainathan, F. Eyma, E. De Luycker, A. Cantarel, and B. Castanié, “Experimental investigation of impact behavior of wood-based sandwich structures,” *Composite Part A: Applied Science and Manufacturing*, vol. 109, pp. 10–19, 2018.
- [88] J. P. Susainathan, F. Eyma, E. De Luycker, A. Cantarel, and B. Castanié, “Manufacturing and quasi-static bending behavior of wood-based sandwich structures,” *Composite Structures*, vol. 182, pp. 487–504, 2017.
- [89] A. Shahdin, L. Mezeix, J. Morlier, Y. Gourinat, and C. Bouvet, “Fabrication and mechanical testing of a new sandwich structure with carbon fiber network core,” *Journal of Sandwich Structures and Materials*, vol. 12, pp. 569–589, 2010.
- [90] A. Shahdin, L. Mezeix, C. Bouvet, J. Morlier, and Y. Gourinat, “Fabrication and mechanical testing of glass fiber entangled sandwich beams: A comparison with honeycomb and foam sandwich beams,” *Composite Structures*, vol. 90, pp. 404–412, 2009.
- [91] I. Ullah, J. Elambasseril, M. Brandt, and S. Feih, “Performance of bio-inspired Kagome truss core structures under compression and shear loading,” *Composite Structures*, vol. 118, pp. 294–302, Dec. 2014.
- [92] H. Wadley, K. Dharmasena, Y. Cheb, P. Dudt, D. Knight, R. Charette, and K. Kiddy, “Compressive response of multilayered pyramidal lattices during underwater shock loading,” *International Journal of Impact Engineering*, vol. 35, pp. 1102–1114, 2008.
- [93] H. L. Fan, F. H. Meng, and W. Yang, “Sandwich panels with Kagome lattice cores reinforced by carbon fibers,” *Composite Structures*, vol. 81, pp. 533–539, 2007.
- [94] R. Gautam and S. Idapalapati, “Performance of strut-reinforced Kagome truss core structure under compression fabricated by selective laser melting,” *Materials and Design*, vol. 164, Feb. 2019.
- [95] H. Z. Jishi, R. Umer, and W. J. Cantwell, “The fabrication and mechanical properties of novel composite lattice structures,” *Materials and Design*, vol. 91, pp. 286–293, Feb. 2016.
- [96] P.-B. Su, B. Han, M. Yang, Z.-H. Wei, Z.-Y. Zhao, Q.-C. Zhang, Q. Zhang, K.-K. Qin, and T. J. Lu, “Axial compressive collapse of ultralight corrugated sandwich cylindrical shells,” *Materials and Design*, vol. 160, pp. 325–337, Dec. 2018.
- [97] B. Han, K. Qin, B. Yu, B. Wang, Q. C. Zhang, and T. J. Lu, “Honeycomb-corrugation hybrid as a novel sandwich core for significantly enhanced compressive performance,” *Materials and Design*, vol. 93, pp. 271–282, Dec. 2016.
- [98] Heimbs and S. Foldcore, “Sandwich Structures and their Impact Performance: An Overview,” in *Dynamic Failure of Composite and Sandwiches Structures* (S. Abrate, B. Castanie, and Y. Rajapakse, eds.), pp. 491–544, Springer, 2013.
- [99] M. N. Velea, C. Schneider, and S. Lache, “Second order hierarchical sandwich structure made of self-reinforced polymers by means of a continuous folding process,” *Materials and Design*, vol. 102, pp. 313–320, July 2016.
- [100] T. K. O’Brien and I. L. Paris, “Exploratory investigation of failure mechanisms in transition regions between solid laminates and X-cor truss sandwich,” *Composite Structures*, vol. 57, pp. 189–204, 2002.
- [101] L.-J. Feng, Z.-T. Yang, G.-C. Yu, X.-J. Chen, and L.-Z. Wu, “Compressive and shear properties of carbon fiber composite square honeycombs with optimized high-modulus hierarchical phases,” *Composite Structures*, vol. 201, pp. 845–856, Oct. 2018.

- [102] G. X. Ha and M. W. Zehn, "Experimental study and finite element simulation of novel napcore sandwich composite," *Composite Part B: Engineering*, vol. 158, pp. 117–130, Feb. 2019.
- [103] J. Bertolini, B. Castanié, J.-J. Barrau, and J.-P. Navarro, "Multi-level experimental and numerical analysis of composite stiffener debonding Part 2: Element and panel level," *Composite Structures*, vol. 90, pp. 392–403, 2009.
- [104] J. Bertolini, B. Castanié, J.-J. Barrau, and J.-P. Navarro, "Multi-level experimental and numerical analysis of composite stiffener debonding Part 1: Non-specific specimen level," *Composite Structures*, vol. 90, pp. 381–391, 2009.
- [105] A. Bergan, J. Bakuckas Jr., J. Awerbuch, and T.-M. Tan, "Assessment of damage containment features of a full-scale PRSEUS fuselage panel," *Composite Structures*, vol. 113, pp. 174–185, 2014.
- [106] V. V. Vasiliev and A. F. Razin, "Anisogrid composite lattice structures for spacecraft and aircraft applications," *Composite Structures*, vol. 76, pp. 182–189, Oct. 2006.
- [107] V. V. Vasiliev, V. A. Barynin, and A. F. Razin, "Anisogrid composite lattice structures: development and aerospace applications," *Composite Structures*, vol. 94, pp. 1117–1127, 2012.
- [108] E. V. Morozov, A. V. Lopatin, and V. A. Nesterov, "Buckling analysis and design of anisogrid composite lattice conical shells," *Composite Structures*, vol. 93, pp. 3150–3162, Nov. 2011.
- [109] M. Buragohain and R. Velmurugan, "Study of filament wound grid-stiffened composite cylindrical structures," *Composite Structures*, vol. 93, pp. 1031–1038, 2011.
- [110] Hexcel Composites. <https://www.hexcel.com/Products/Tooling/HexTool-Tooling-Material>. Accessed: 2018-12-13.
- [111] Lamborghini. <https://www.lamborghini.com/fr-en/brand/innovation-excellence/forged-composites>. Accessed: 2018-12-13.
- [112] X. Aubard, C. Cluzel, L. Guitard, and P. Ladevèze, "Damage modeling at two scales for 4D carbon/carbon composites," *Computers and Structures*, vol. 78, pp. 83–91, Nov. 2000.
- [113] K. Bilisik, "Three-dimensional braiding for composites: A review," *Textile Research Journal*, vol. 83, pp. 1414–1436, 2013.
- [114] K. Bilisik, "Multiaxis three-dimensional weaving for composites: A review," *Textile Research Journal*, vol. 82, pp. 725–743, 2012.
- [115] E. De Luycker, F. Morestin, P. Boisse, and D. Marsal, "Simulaton of 3D interlock composite preforming," *Composite Structures*, vol. 88, pp. 615–623, 2009.
- [116] T. Huang, Y. Wang, and G. Wang, "Review of the Mechanical Properties of a 3D Woven Composite and its Applications," *Polymer - Plastics Technology and Engineering*, vol. 57(8), pp. 740–756, 2018.
- [117] R. Geerinck, I. De Baere, G. De Clercq, L. Daelemans, and K. De Clerck, "One-shot production of large-scale 3 woven fabrics with integrated prismatic shpaed cavities and their applications," *Materials and Design*, vol. 165, March 2019.
- [118] K. Leong, S. Ramakrishna, Z. M. Huang, and G. A. Bibo, "Potential of knitting for engineering composites - a review," *Composites Part A: Applied Science and Manufacturing*, vol. 31(3), pp. 197–220, 2000.
- [119] B. T. Astrom, *Manufacturing of polymer composite*. Chapman and Hall, 2002.
- [120] F. C. Campbell, *Manufacturing Processes For Advanced Composites*. Elsevier Advanced Technology, 2004.
- [121] U. P. Breuer, *Commercial Aircraft Composite Technology*. Springer, 2016.
- [122] D. Gay, *Composite Materials: Design and Applications Third Edition*. CRC Press, 2015.
- [123] X. Wang, M. Jiang, Z. Zhou, J. Gou, and D. Hui, "3D printing of polymer matrix composites: A review and prospective," *Composites Part B: Engineering*, vol. 110, pp. 442–458, 2017.
- [124] J. D. Suh and D. G. Lee, "Manufacture of composite screw rotors for air compressors by RTM process," *Journal of Materials Processing Technology*, vol. 113, pp. 196–201, June 2001.

- [125] M. Elkington, D. Bloom, C. Ward, A. Chatzimichali, and K. Potter, “Hand layup: understanding the manual process,” *Advanced Manufacturing: Polymer and Composites Science*, vol. 1, pp. 138–151, Nov. 2015.
- [126] T. Kikuchi, H. Hamada, A. Nakai, A. Ohtani, A. Goto, Y. Takai, A. Endo, C. Narita, T. Koshino, and A. Fudauchi, “Relationships between degree of skill, dimension stability and mechanical properties of composite structure in hand lay-up method,” *The 19th International Conference on Composite Materials*, 2013.
- [127] T. Kikuchi, Y. Tani, Y. Takai, A. Goto, and H. Hamada, “Mechanical Properties of Jute Composite by Spray up Fabrication Method,” *Energy Procedia*, vol. 56, pp. 289–297, 2014.
- [128] J. Verrey, V. Michaud, and J.-A. E. Manson, “Dynamic capillary effects in liquid composite moulding with non-crimp fabrics,” *Composites Part A: Applied Science and Manufacturing*, vol. 37, pp. 92–102, Jan. 2006.
- [129] B. Vieille, W. Albouy, L. Chevalier, and L. Taleb, “About the influence of stamping on thermoplastic-based composites for aeronautical applications,” *Composites Part B: Engineering*, vol. 45(1), pp. 821–834, Feb. 2013.
- [130] B.-A. Behrens, A. Raatz, S. Hübner, C. Bonk, F. Bohne, and M. Bruns, C. Micke-Camuz, “Automated Stamp Forming of Continuous Fiber Reinforced Thermoplastics for Complex Shell Geometries,” *Procedia CIRP*, vol. 66, pp. 113–118, 2017.
- [131] C. Grant, “Automated processes for composite aircraft structure,” *Industrial Robot: the international journal of robotics research and application*, vol. 33, no. 2, pp. 117–121, 2006.
- [132] M. Rakhshbahar and M. Sinapius, “A novel approach: combination of automated fiber placement (AFP) and additive layer manufacturing (ALM),” *Journal of Composite Sciences*, vol. 2, July 2018.
- [133] P. Maung, B. G. Prusty, J. M. White, M. David, A. W. Philips, and N. A. St John, “Structural performance of a shape-adaptive composite hydrofoil using automated fibre placement,” *Engineering Structures*, vol. 183, pp. 351–365, March 2019.
- [134] E. Poodts, G. Minak, L. Mazzocchetti, and L. Giorgini, “Fabrication, process simulation and testing of a thick CFRP component using the RTM process,” *Composites Part B: Engineering*, vol. 56, pp. 673–680, Jan. 2014.
- [135] Y. Kyosev, *Advances in Braiding Technology - Specialized Techniques and Applications*. Woodhead Publishing, 2016.
- [136] A. Krzyzak, M. Mazur, M. Gajewski, K. Drozd, A. Komorek, and P. Przybylek, “Sandwich Structured Composites for Aeronautics: Methods of Manufacturing Affecting Some Mechanical Properties,” *International Journal of Aerospace Engineering*, vol. 2016, May 2016.
- [137] J. Grünewald, P. Parlevliet, and V. Altstädt, “Manufacturing of thermoplastic composite sandwich structures: A review of literature,” *Journal of Thermoplastic Composite Materials*, vol. 30(4), pp. 434–464, Apr. 2017.
- [138] A. C. Long, *Design and Manufacture of Textile Composites*. Woodhead Publishing, 2005.
- [139] S. C. Joshi, “The pultrusion process in polymer matrix composites,” in *Manufacturing techniques for polymer matrix composites (PMCs)* (S. G. Advani and K.-T. Hsiao, eds.), ch. 12, pp. 381–408, Woodhead Publishing, 2012.
- [140] L. Sorrentino, M. Marchetti, C. Bellini, A. Delfini, and F. Del Sette, “Manufacture of high performance isogrid structure by robotic filament winding,” *Composite Structures*, vol. 164, pp. 43–50, March 2017.
- [141] W. D. Li, G. Liu, X. L. Hu, X. F. An, X. Y. Zhong, Y. Li, and X. S. Yi, “The Processing Characteristics and Mechanical Properties of Semi-Prepreg RTM composites,” *Advanced Materials Research*, vol. 721, pp. 153–158, 2013.
- [142] Composites World. <https://www.compositesworld.com/articles/airbus-a350-update-braf-fpp>. Accessed: 2018-12-13.
- [143] J. C. Mankins, “Technology readiness and risk assessments: A new approach,” *Acta Astronautica*, vol. 65, pp. 1208–1215, Nov.-Dec. 2009.

