



HAL
open science

From Quantum Physics to Digital Communication: Single Side Band Continuous Phase Modulation

Haïfa Farès, Christian Glattli, Yves Louët, Jacques Palicot, Christophe Moy,
Preden Roulleau

► **To cite this version:**

Haïfa Farès, Christian Glattli, Yves Louët, Jacques Palicot, Christophe Moy, et al.. From Quantum Physics to Digital Communication: Single Side Band Continuous Phase Modulation. *Comptes Rendus. Physique*, 2018, 19 (1-2), pp.54-63. 10.1016/j.crhy.2018.01.004 . hal-02087891

HAL Id: hal-02087891

<https://hal.science/hal-02087891>

Submitted on 2 Apr 2019

HAL is a multi-disciplinary open access archive for the deposit and dissemination of scientific research documents, whether they are published or not. The documents may come from teaching and research institutions in France or abroad, or from public or private research centers.

L'archive ouverte pluridisciplinaire **HAL**, est destinée au dépôt et à la diffusion de documents scientifiques de niveau recherche, publiés ou non, émanant des établissements d'enseignement et de recherche français ou étrangers, des laboratoires publics ou privés.

From Quantum Physics to Digital Communication: Single Side Band Continuous Phase Modulation

Haïfa Farès^{a,b}, D. Christian Glattli^{b,*}, Yves Louët^a, Jacques Palicot^a,
Christophe Moy^a, Preden Roulleau^b

^a*IETR - UMR CNRS 6164, CentraleSupélec, avenue de la Boulaie - CS 47601 35576
CESSON-SEVIGNE Cedex, France*

^b*SPEC UMR 3680 CEA-CNRS, Université Paris-Saclay, CEA-Saclay, 91191
Gif-Sur-Yvette, France*

Abstract

In the present paper, we propose a new frequency-shift keying continuous phase modulation (FSK-CPM) scheme having, by essence, the interesting feature of single side-band (SSB) spectrum providing a very compact frequency occupation. First, the original principle, inspired from quantum physics (levitons), is presented. Besides, we address the problem of low-complexity coherent detection of this new waveform, based on orthonormal wave-functions used to perform matched-filtering for efficient demodulation. Consequently, this shows that the proposed modulation can operate using existing digital communication technology, since only well-known operations are performed (e.g. filtering, integration). This SSB property can be exploited to allow large bit rates transmissions at low carrier frequency without caring about image frequency degradation effects typical of ordinary double side-band signals.

Keywords: CPM, single side band signal, low-complexity, orthonormal wave functions, matched-filter.

[☆]This work was supported by the ERC Proof of Concept 680875 C-Levitonics.

*Corresponding author

1. Introduction

Communicating with a far away destination has always been a fundamental concern of mankind. However, not long ago, postal mail remained the only effective means able to perform this function, before the appearance of the telegraph and then the telephone, two major inventions that marked the beginning of the area of Telecommunications. From the earliest developments of telephony and radio, the signals are adapted to the transmission channel by means of amplitude or/and phase modulation of a sinusoidal carrier wave. All of these modulation methods are characterized by two-sided signals, that is, a spectrum centered around the carrier frequency having frequency components below and above this carrier frequency. Since the lower band contains the same information as the upper band, one of the most trivial mean for optimizing the spectral occupancy is to keep only one of these two sides by using a bandpass filtering. The Hilbert transform proposed by Hartley in [1] is a simpler mean of suppressing one of the two sidebands, after generating the modulated signal. It consists in constructing, by using a wide-band phase shifter, the sum or difference of the in-phase and quadrature portion of the modulated signal, respectively, to preserve either the upper sideband or the lower sideband. A variant was proposed in [2]. In this paper, we present a new original waveform that directly generates a signal with a single sideband spectrum. By *directly* we mean without any additional treatment as described above.

This newly patented modulation is part of the Frequency Shift Keying (FSK) continuous phase modulation (CPM) family, known to be a good candidate to limit the transmitted signal distortion [3, 4]. For instance, it generates constant envelope waveforms, which is particularly useful when employing nonlinear amplifiers. The key idea to generate directly a single side band modulated signal is the use of a generic frequency pulse with Lorentzian shape. The Lorentzian shape provides specific properties to a wave which were found and exploited in fundamental quantum physics for the on-demand injection of a single electron in a quantum conductor as a new excitation called a leviton. This proposed

modulation is then suggested as a first application of a classical levitonics to digital transmissions based on CPM. Notwithstanding all these favorable aspects (power efficiency and single side band transmission), alike current CPM schemes, the proposed modulation scheme, hereafter called Single Side band
35 Frequency Shift Keying (SSB-FSK), may suffer from implementation complexity. In this paper, we focus on a low-complexity coherent receiver originating from orthonormal wave-functions used to perform matched-filter detection.

This paper is organized as follows. The fundamental modulation principle derived from quantum physics is introduced in Section 2. In Section 3, we briefly
40 describe the system model. Then, a low complexity coherent receiver is detailed in Section 4. Numerical results are reported in Section 5. Finally, in Section 6, we draw some conclusions and define some perspectives.

2. The origin of SSB-FSK modulation : levitons from quantum physics

The ability to control individual electrons in an electronic conductor has been
45 for long time considered by the community of Quantum Physics as a hot topic. It has been widely investigated in order to pave the way for novel quantum technologies. The topic of on-demand injection of single electrons has been considered using several approaches [5, 6, 7, 8, 9, 10]. Here, we consider the technique of voltage pulses applied on a contact to inject a charge in a conductor.
50 The solution, which seems to be trivial, has been implicitly proposed in the theoretical work by Levitov et al [10]. When applying a short voltage pulse $V(t)$ on a contact of a quantum conductor carrying a single electronic mode, an elementary current pulse $I(t) = e^2V(t)/h_0$ is then generated, where e is the charge of an electron and h_0 is the Planck constant. Adjusting the amplitude
55 and duration of the pulse so as to generate the charge $Q = \int I(t)dt = e$, a single electron is then injected from the contact to the conductor. In general, the voltage pulse perturbs all the electrons of the conductor resulting in a number of unwanted excitations in the form of electrons (holes) with energy respectively above (below) the Fermi energy of the conductor. Surprisingly, it has been found

60 that a remarkably particular shape of voltage pulses, a Lorentzian and only that
 shape, excites just a single electron above the Fermi energy. With Lorentzian
 voltage pulses, a single electron can be injected in the form of an exceptional
 minimal excitation state called a leviton where the unwanted excitations are
 absent. Levitons, have been recently produced and observed in [8] using a
 65 nanoscale circuit consisting of two electrodes connected by a small conductor.
Dubois et al. applied Lorentzian-shaped voltage pulses on one electrode to
 generate levitons that travel through the conductor to the other electrode [8, 9],
 demonstrating the fundamental prediction of [10]. This major breakthrough
 has also been exploited to perform the analog of a Hong-Ou-Mandel experiment
 70 known from optics, where electrons can be viewed as flying qubits propagating in
 a ballistic conductor [8]. When a voltage pulse is applied, the phase of electronic
 quantum waves is modulated as $\varphi(t) = (e/h_0) \int V(t)dt$. The key principle
 behind the remarkable levitonic quantum state is that for a Lorentzian pulse,
 the electron energy spectrum resulting from the phase modulation (their power
 75 spectrum density in frequency) becomes *single side band*. Hence was born the
 idea of exploiting this original spectral property not only to quantum electronic
 waves but also to all types of waves, even classical: electromagnetic, acoustic,
 etc [11].

3. System model

The signal carrying the binary information is the constant envelope signal
 given by

$$\begin{aligned}
 s(t) &= \sqrt{\frac{E_s}{T_s}} e^{j(2\pi f_c t + \varphi(t))} \\
 &= \sqrt{\frac{E_s}{T_s}} e^{j(2\pi f_c t + h \sum_{k=-\infty}^{+\infty} a_k \varphi_0(t - kT_s))},
 \end{aligned} \tag{1}$$

where E_s is the average symbol energy, T_s is the duration of information symbol
 a_k (taking values in the alphabet $\{0, 1\}$), f_c is the carrier frequency, h is an inte-
 ger modulation index ensuring an 2π phase increment, $\varphi(t)$ is the phase function
 and $\varphi_0(t)$ is the elementary Levitonic phase-shift function. To start, we consider

frequency pulses truncated to a length L for further ease in demodulation. They are given by

$$\varphi_0(t) = 2\mu(L) \arctan\left(\frac{t}{w}\right). \quad (2)$$

80 where $\mu(L)$ is a fixed correcting factor that will be defined latter.

The derivative of the phase-shift function, $g(t)$, which consists in the frequency pulse, is zero everywhere except in the interval $[-LT_s/2, +LT_s/2]$ where it is a Lorentzian given by

$$g(t) = \frac{d\varphi_0(t)}{dt} = \mu \frac{2w}{t^2 + w^2}, \quad t \in [-LT_s/2, LT_s/2] \quad (3)$$

$$\int_{-t}^t g(\tau) d\tau = \varphi_0(LT_s/2) - \varphi_0(-LT_s/2) = 2\pi, \quad t \geq LT_s/2$$

In the sinusoidal signal $s(t)$, we perform a phase coding where the k -th symbol of duration T_s contributes to the total phase $\varphi(t)$ of the carrier by the quantity $2\mu a_k \arctan\left(\frac{t-kT_s}{w}\right)$ where w is the pulse width, a tuning parameter impacting greatly the performance, particularly the spectral efficiency of the transmitted signal $s(t)$. In other words, we associate a Lorentzian pulse with
 85 a phase increment equal to $2h\pi$ to symbol 1 and no pulse to symbol 0. The derivative of the total phase is then a sum of Lorentzians $\frac{2\mu w}{(t-kT_s)^2 + w^2}$, centered on kT_s and weighted by the symbols a_k and truncated to the length L . Note that if the modulation index h is a positive integer, the spectrum is located
 90 only in the upper band with respect to f_c . The modulation index h may also be a negative integer; in this case, we will obtain the mirror spectrum with respect to f_c and no component in this upper band. From this observation, no antipodal coding is possible at the symbol level. Otherwise, the spectrum will return perfectly bilaterally centered around f_c . The components below f_c
 95 are representing from the contribution of the bits $b_k = 0$ encoded in $a_k = -1$; and the components above f_c are representing from the contribution of the bits $b_k = 1$ coded in $a_k = 1$. Figure 1.(a) shows the phase derivative signal for the bit sequence $\{0, 0, 1, 1, 1, 0, 1\}$; The phase is then integrated to generate the signal of the Figure 1.(b). This latter shows the continuity of this phase.

Furthermore, given that the Lorentzian pulse decreases very slowly (2π

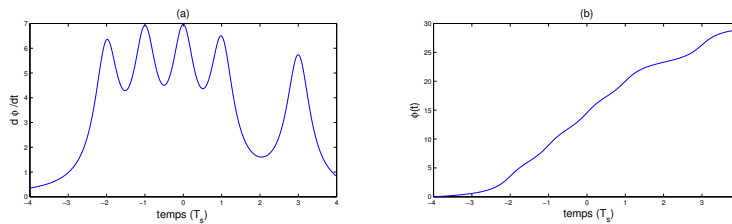

Figure 1: Generated signals with SSB-FSK modulation of the bit sequence $\{0, 0, 1, 1, 1, 0, 1\}$: (a) Phase derivative (Lorentzian pulses), (b) Evolution of the phase (cumulative phase summing $2\mu a_k \arctan\left(\frac{t-kT_s}{w}\right)$).

phase increment is ensured for $L = \infty$), μ is a correcting factor introduced to keep a 2π phase increment when the frequency pulse $g(t)$ is truncated to a finite $L > 1$ symbol durations. This factor is defined as the ratio between the total phase increment without any truncation and the one obtained after Lorentzian truncation :

$$\mu(L) = \frac{2\pi}{\int_{-LT_s/2}^{LT_s/2} \frac{2w}{t^2+w^2} dt} = \frac{\pi}{\arctan\left(\frac{LT_s}{2w}\right)}. \quad (4)$$

100 In Figure 2, we illustrate the Lorentzian pulse, for different width values $w/T_s = 0.28, 0.37, 0.55$. As $g(t)$, the frequency pulse, is partial-response (with long length $L > 1$), the SSB-FSK modulation exhibits inter-symbol interference (ISI) which is obviously expected and goes up with w . It is therefore imperative to choose a limited width w for Lorentzian pulses to reduce ISI effects on bit
105 error rate (BER) performance.

In order to evaluate the Bit Error Probability (BER) performance, we consider a point-to-point communication system over an additive white Gaussian noise (AWGN) channel. The power-limited input signal \mathbf{s} (a long sequence of symbols) is summed to the complex noise $\mathbf{z} \sim \mathcal{CN}(0, \sigma_0^2)$ resulting in the output \mathbf{y} , which is defined, at time t , as

$$y(t) = s(t) + z(t), \quad (5)$$

with σ_0^2 the Gaussian noise variance.

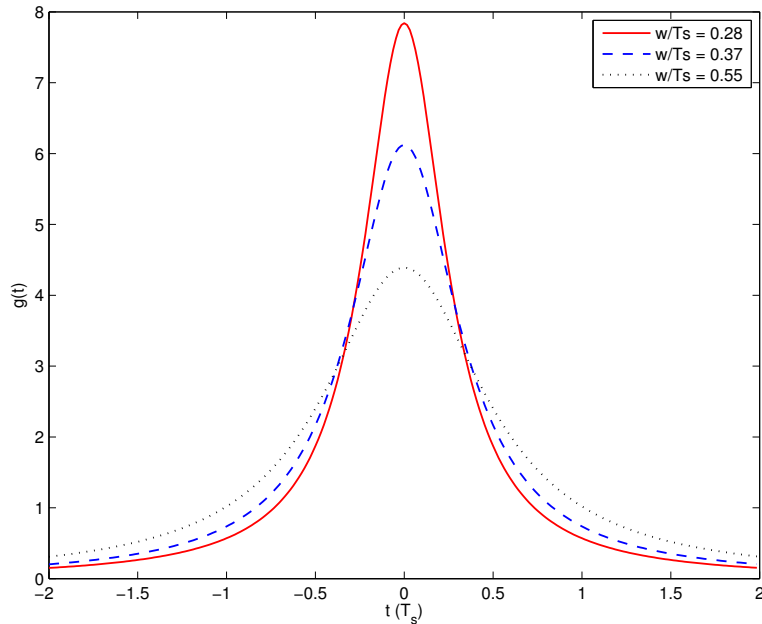

Figure 2: Length- $4T_s$ frequency pulse: the Lorentzian pulse for different width values, $w/T_s = 0.28, 0.37, 0.55$.

4. Low-complexity coherent detector

In this section, a coherent symbol-by-symbol detection method is presented. This method exploits orthogonality between signals relative to bits 0 and 1. For Matched Filter (MF) based detector, the decision on one symbol is made based on the observation of one received symbol. The memory of CPM signals introduced by the phase continuity can be used to improve BER performance of MF-based detector by making decision on one symbol based on a whole observation window (a sequence of received symbols); this demodulation method is called Average Matched Filter (AMF) based detection.

4.1. Orthonormal wave-functions

Using $\varphi_0(t)$, a non-truncated Levitonic pulse given in (2) for $\mu = 1$, we define $u_{\tilde{h}}(t)$, $\tilde{h} = 0, 1, 2, \dots, N$, from $s_h(t) = e^{jh\varphi_0(t)}$, a set of orthonormal wave-functions, as

$$\begin{aligned} u_{\tilde{h}}(t) &= \frac{1}{\sqrt{2\pi}} \frac{e^{j\tilde{h}\varphi_0(t)}}{t - jw} \\ &= \frac{1}{\sqrt{2\pi}} \frac{(t + jw)^{\tilde{h}-1}}{(t - jw)^{\tilde{h}}}. \end{aligned} \quad (6)$$

The set of $\{u_{\tilde{h}}(t)\}$ for all integer h verifies the following orthogonal property:

$$\int_{-\infty}^{+\infty} u_{\tilde{h}}^*(t) u_{\tilde{h}'}(t) dt = \delta_{\tilde{h}, \tilde{h}'} \quad (7)$$

Based on this interesting observation and remarking that $\frac{d\varphi_0}{dt} = \frac{1}{(t-jw)^*(t-jw)}$, we can derive the following equation which will be central to enable matched filter detection:

$$\frac{1}{2\pi} \int_{-\infty}^{+\infty} s_{\tilde{h}}^*(t) s_{\tilde{h}'}(t) \frac{d\varphi_0(t)}{dt} dt = \delta_{\tilde{h}, \tilde{h}'}. \quad (8)$$

where $\frac{d\varphi_0(t)}{dt}$ is a weighting function and $s_{\tilde{h}}(t)$ is an SSB-FSK modulated signal, which can be rewritten as

$$s_{\tilde{h}}(t) = e^{j\tilde{h}\varphi_0(t)} = \left(\frac{t + jw}{t - jw} \right)^{\tilde{h}}. \quad (9)$$

Furthermore, it is important to notice that even when considering integration function over a finite period T_s , the orthogonality property, being no longer exact is still quantitatively satisfactorily verified:

$$\frac{1}{2\pi} \int_{-T_s/2}^{+T_s/2} s_{\tilde{h}}^*(t) s_{\tilde{h}'}(t) \frac{d\varphi_0(t)}{dt} dt \simeq \delta_{\tilde{h}, \tilde{h}'}. \quad (10)$$

4.2. Matched filter based detector

The block diagram of the proposed MF-based detector is shown in Figure 3. For binary transmission, matched filtering is inspired from the integration function defined in (10), for $\tilde{h} = ha_k$, where $a_k = 0, 1$. The matched filtering exploits the orthogonality between wave-functions of SSB-FSK signals relative

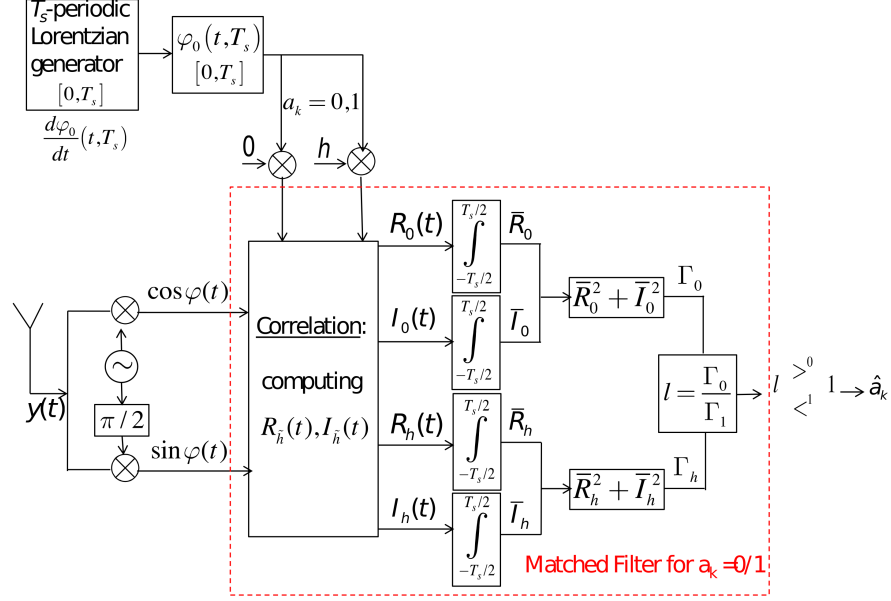

Figure 3: Block diagram of the MF-based detector.

to symbols 0 and 1. The detection of the transmitted symbol, using the received signal after the carrier demodulation $\tilde{y}(t)$, is based on the computation of the following correlation functions for $\tilde{h} = 0, h$

$$\Gamma_{\tilde{h}}(t) = \left| \int_{t-T_s/2}^{t+T_s/2} \tilde{y}(t) s_{\tilde{h}}^*(t) \frac{d\varphi_0(t)}{dt} dt \right|^2, \quad (11)$$

Rewriting the correlation functions, we obtain

$$\Gamma_{\tilde{h}}(t) = \left(\int_{t-T_s/2}^{t+T_s/2} R_{\tilde{h}}(t) dt \right)^2 + \left(\int_{t-T_s/2}^{t+T_s/2} I_{\tilde{h}}(t) dt \right)^2 \quad (12)$$

where

$$R_{\tilde{h}}(t) = \left\{ \left[\cos \varphi(t) \cos(\tilde{h}\varphi_0(t)) + \sin \varphi(t) \sin(\tilde{h}\varphi_0(t)) \right] \frac{d\varphi_0(t)}{dt} \right\} \quad (13)$$

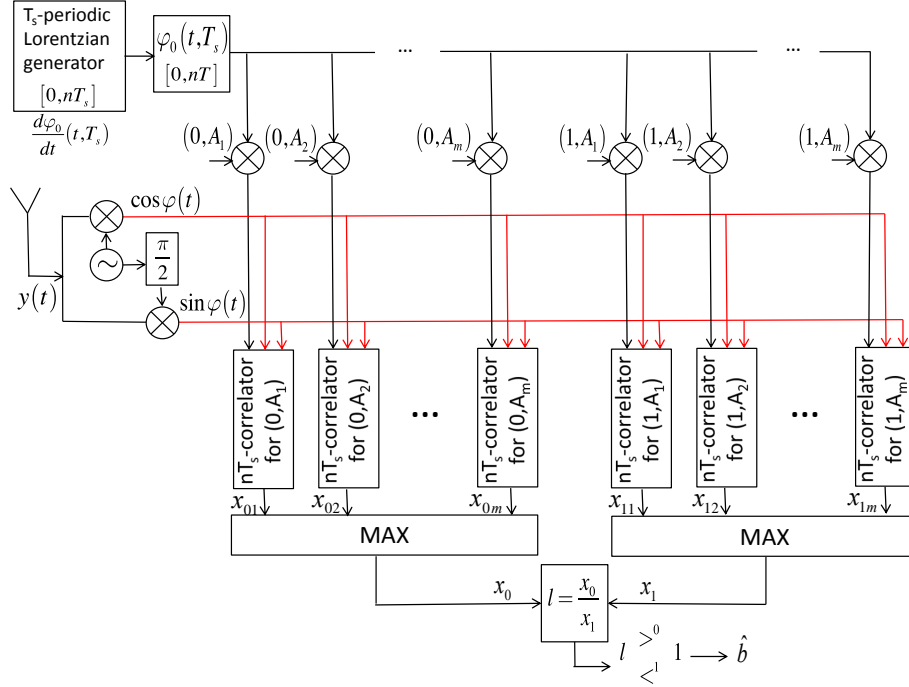

Figure 4: Block diagram of the AMF-based detector.

and

$$I_{\tilde{h}}(t) = \left\{ \left[\sin \varphi(t) \cos(\tilde{h}\varphi_0(t)) - \cos \varphi(t) \sin(\tilde{h}\varphi_0(t)) \right] \frac{d\varphi_0(t)}{dt} \right\}. \quad (14)$$

Finally, the correlation functions are then used in order to establish the likelihood ratio test

$$l = \frac{\Gamma_0}{\Gamma_h} \begin{matrix} > 0 \\ < 1 \end{matrix} 1. \quad (15)$$

4.3. Average matched filter based detector

Although its simplicity, the main drawback of MF-based detector is the
 120 Inter-symbol interference (ISI), which is not taken into account. The AMF-
 based detector is then proposed to take advantage from the memory specific
 to CPM signals. The block diagram of the proposed AMF-based detector is

shown in Figure 4. The key idea consists of observing n symbols of an SSB-FSK waveform and producing a decision on one symbol. As the detector is coherent, the decision is made on the first symbol by observing the waveform during this symbol period and $n - 1$ additional symbol periods.

The SSB-FSK modulated signal during the observation interval is denoted by $s(t, a_l, Ak)$ where A_k represents a particular symbol sequence, i.e., the $n-1$ -tuple a_2, a_3, \dots, a_n . The detection problem is then to observe $s(t, a_l, Ak)$ distorted by noise and produce a decision on a_1 (either 0 or 1).

Using the principles described in Sub-section 4.2 for symbol-by-symbol filtering and carrying out the integration over the nT_s observation intervals, the likelihood ratio becomes

$$l = \frac{\max \left\{ \left| \int_{-T_s/2}^{T_s/2} y(t) s^*(t, 0, A_1) \frac{d\varphi_0(t)}{dt} dt \right|^2, \dots, \left| \int_{-T_s/2}^{T_s/2} y(t) s^*(t, 0, A_m) \frac{d\varphi_0(t)}{dt} dt \right|^2 \right\}}{\max \left\{ \left| \int_{-T_s/2}^{T_s/2} y(t) s^*(t, 1, A_1) \frac{d\varphi_0(t)}{dt} dt \right|^2, \dots, \left| \int_{-T_s/2}^{T_s/2} y(t) s^*(t, 1, A_m) \frac{d\varphi_0(t)}{dt} dt \right|^2 \right\}}. \quad (16)$$

In order to compute this likelihood ratio, the receiver correlates the received signal with each of the $m = 2^{n-1}$ possible transmitted signals followed by the symbol $a_k = 1$. A similar operation of correlation with the m possible transmitted signals followed by the symbol $a_k = 0$ is performed. Using the AMF-based detector improves the BER performance with a reasonable increase in the complexity for reduced observation intervals.

5. Numerical results and comparisons

5.1. SSB Spectral Property

In order to illustrate the single side band spectral property, we plot, in Figure 5, the power spectral density (PSD) of the SSB-FSK modulated signal averaged over 10 spectra corresponding to corresponding to 10 streams of 2048 bits each. The analytical derivation of this PSD has been detailed in [12]. For this illustration, non truncated Lorentzian pulses of width $w = 0.37T_s$ are used, i.e., numerically, we choose a large enough L value to guarantee a phase increment equal to 2π (what corresponds to $\mu = 1$). The frequencies are in

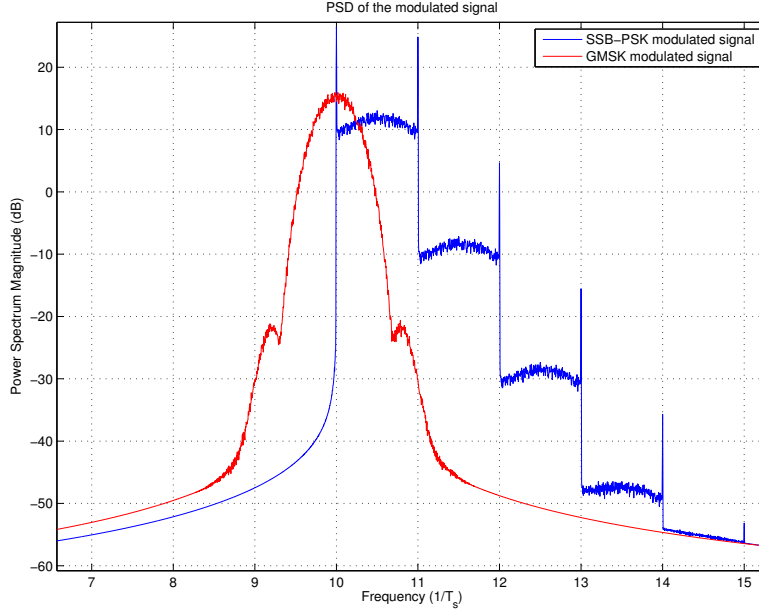

Figure 5: Comparison of the power spectral densities: in blue for an SSB-FSK signal, in red for a GMSK signal, for the same carrier frequency $f_c = 10/T_s$.

units of $1/T_s$. The carrier frequency is $f_c = 10/T_s$. In this example, we choose $h = 1$, a positive integer; as a result all the spectral components of the signal are located in the upper band with respect to f_c . For comparison, we also present the PSD of the GMSK modulated signal.

150 Comparing the PSDs of the SSB-FSK and the GMSK modulated signal, we can note that the PSD of the SSB-FSK is indeed unilateral and is no more symmetrical with respect to the carrier frequency f_c as for the GMSK case. Almost all of the power is concentrated in a $1/T_s$ frequency band and the power spectrum decreases steeply in steps of 20 dB, spaced by frequential periods of

155 $1/T_s$. This exponential decrease is equal to $e^{-4\pi w f}$, which is equivalent to 1/100 in linear scale and to 20 dB in logarithmic scale for $w/T_s = 0.37$. This power

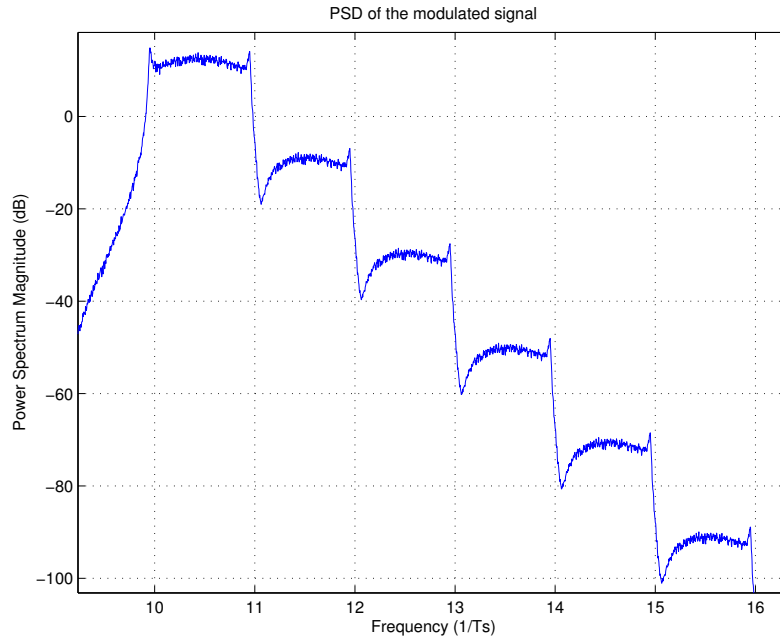

Figure 6: Power spectral density of an SSB-FSK signal with 95% of the phase increment of a pure Lorentzian.

exponential decay ($e^{-4\pi wf}$) of the SSB-FSK can be tuned by the Lorentzian width w . A trade-off on the value of w has to be found in order to balance on one side the ISI reduction by limiting w and on the other side ensuring a fast
 160 power decay outside the useful band by increasing w .

Furthermore, spikes at frequencies f_c , $f_c + 1/T_s$, $f_c + 2/T_s$, etc, are also present in the PSD illustration of the SSB-FSK. Their presence is an immediate consequence of the 2π phase increment, what is well-known in conventional phase modulation techniques [13]. These spectral spikes can be removed by
 165 deviating a little from this critical value, at the cost of a reappearance of very low amplitude components in the lower band. The PSD of the SSB-FSK with a phase increment equal to 95 % of 2π is represented on Figure 6. The con-

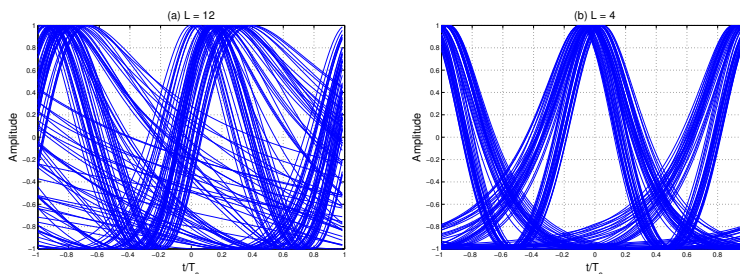

Figure 7: Eye diagram of SSB-FSK modulated using Lorentzian pulses truncated to L symbol periods : (a) $L = 12$, (b) $L = 4$.

figuration of the signals considered in Figure 5 has been maintained for this illustration. The major difference is the clear reduction of the spectral spikes.
 170 However, its spectral occupation has slightly increased.

Table 1 provides the effect of the Lorentzian truncation on the PSD of the SSB-FSK modulated signal. In this table, we present the spectral occupation of the modulated signal for several values of $L = \infty, 12, 4, 2$.

This spectral occupation, denoted by BW , is expressed in terms of normalized frequency band ($1/T_s$) occupied by 98% of the signal power transmitted
 175 for $w = 0.37T_s$. For comparison, we also give the spectral occupation of a GMSK signal. For instance, for $BT = 0.3$, $BW = 0.86$. We can clearly note through these results that for non-truncated Lorentzian pulses, the spectral occupation of the SSB-FSK modulation remains close to those reached by the
 180 GMSK modulation. However, the more truncated the waveform is, the more spectral occupation increases.

Table 1: Spectral occupation and correcting factor μ for different values of L

SSB-FSK				
L	∞	12	4	2
μ	1	1.04	1.13	1.29
BW	1	1.08	1.26	1.53

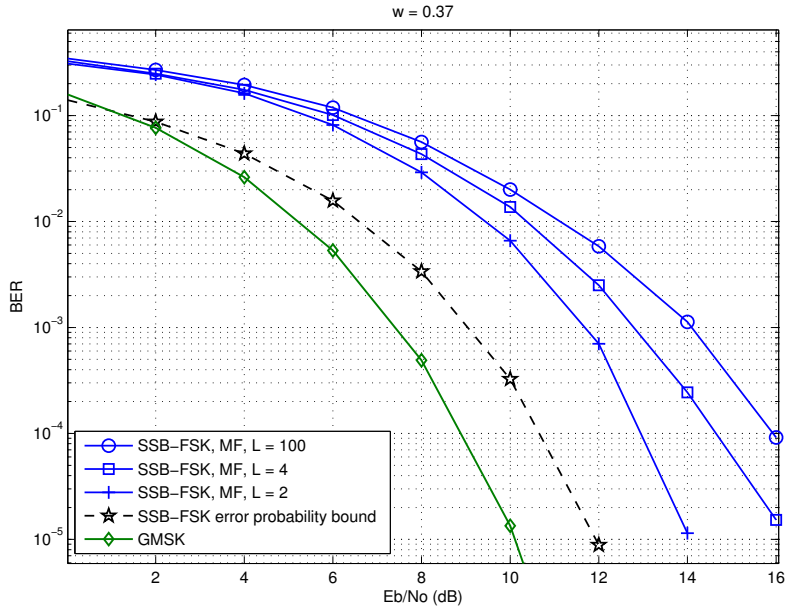

Figure 8: BER performance of MF-based detector for several truncation scenarios $L = 100, 4, 2$.

5.2. Bit Error Rate performance

This sub-section investigates the performance of the SSB-FSK in terms of BER over an AWGN channel. As this particular performance metric is very sensitive to the ISI level, we first evaluate the impact of the Lorentzian pulse length on the ISI. To do so, we provide in Figure 7 the eye diagram of the SSB-FSK signal for $L = 12$ and 4. We clearly observe much more interference between symbols for a truncation at $L = 12$ compared to $L = 4$. As a result, the demodulation of the signal passing through a noisy channel in the presence of the ISI level for $L = 12$ will be considerably less efficient compared to $L = 4$. From Table 1 and Figure 7, a truncation of the Lorentzian at $L = 4$ periods seems to be a good compromise between the preservation of the spectral occupation (by conserving the SSB property) and reducing the ISI level.

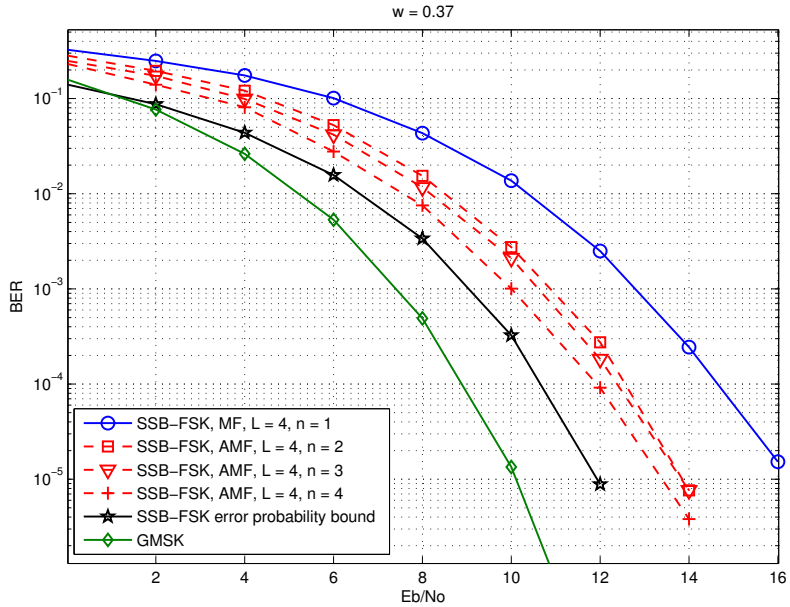

Figure 9: BER performance of AMF-based detector for several observation interval values $n = 2, 3, 4$.

In Figure 8, we plot BER curves of SSB-FSK modulation using MF-based detector for several Lorentzian pulse length values $L = 100, 4, 2$, as a function of E_b/N_0 the bit-energy-to-noise ratio. This quantifies the effect of truncation on the performance of the proposed demodulation scheme and thus its immunity against ISI. It is a non-surprising result that SSB-FSK modulation with the most severe truncation of the Lorentzian pulse is the most efficient, since it is subject to the the lowest ISI level. A bound on the bit error probability is given in order to illustrate the potential of this new modulation. This performance bound is described using error events and minimum distance simulation [14, 15]. In order to simulate the minimum distance relative to this modulation, we assume the following error event: we transmit the symbol sequence \mathbf{a}_{Tx} and we receive the

symbol sequence \mathbf{a}_{Rx} , defined both as

$$\begin{aligned}\mathbf{a}_{\text{Tx}} &= (\dots, a_{e-1}, a_e, a_{e+1}), \\ \mathbf{a}_{\text{Rx}} &= (\dots, a_{e-1}, \bar{a}_e, a_{e+1}).\end{aligned}\tag{17}$$

The phases of SSB-PSK modulated signals relative to both \mathbf{a}_{Tx} and \mathbf{a}_{Rx} information sequences diverge at position e and converge again due to the 2π phase increment. Consequently, the minimum Euclidean distance d_{min} is then relative to a single-symbol error event. The probability of bit error is then bounded as

$$P_b \leq \frac{1}{2} Q\left(\sqrt{d_{\text{min}}^2 \frac{E_b}{N_0}}\right),\tag{18}$$

where $Q(x) = \frac{1}{\sqrt{2\pi}} \int_x^\infty e^{-u^2/2} du$.

195 Furthermore, BER curves of SSB-FSK modulation using AMF-based detector for several observation interval values are given in Figure 9 for $L = 4$ and are compared to BER curve using MF-based detector. For $n = 2$, a gain of almost 2 dB at BER = 10^{-3} is offered with respect to MF-based detector BER performance. Smaller gains are observed for larger values of n ($n = 3, 4$).
200 The best performance of the AMF-based detector is given for $n = L$. However, even if the AMF-based detector is performing much better than the MF-based detector, this demodulation scheme is not the optimal one and it is still around 1 dB above the optimal performance.

Finally, even if SSB-FSK offers a lower BER performance compared to
205 GMSK due to a higher amount of ISI caused by a significant overlap between Lorentzian pulses, the proposed waveform may be preferred in some specific transmission contexts. For instance, the total absence of lower side band allows to operate with symbol rate $1/T_s$ much larger than the carrier frequency f_c , typically $4f_c$ without deterioration of the BER as there is no interference with
210 the mirror spectrum.

6. Conclusions

In this paper, we present a new single side band waveform. We explain the eve of this idea derived from quantum physics. Moreover, we compare its

power spectral density with that obtained from a conventional continuous phase
215 modulation (GMSK) widely used in transmission contexts that can be targeted
by this new proposal. Being a partial response, like the GMSK, this waveform
exhibits inter-symbol interference. A tradeoff between spectral occupation and
demodulation efficiency in the presence of noise is then fixed. Two different
demodulation schemes have been developed and simulation results in terms
220 of BER have been given in order to evaluate their potential. Since none of
them achieves optimal performance, future work will focus on Viterbi based
demodulation scheme using pulse amplitude modulation (PAM) decomposition.
This is not straightforward since the proposed SSB-FSK scheme has an integer
modulation index ensuring a 2π phase increment.

225 **References**

- [1] R. V. L. Hartley, Us patent 1666206.
- [2] D. K. Weaver, A third method of generation and detection of single-
sideband signals, Proceeding on the IRE (1956) 1703–1705.
- [3] J. B. Anderson, T. Aulin, C. E. W. Sundberg, Digital phase modulation,
230 New york: Plenum Press.
- [4] C. H. Kuo, K. M. Chugg, On the bandwidth efficiency of CPM sig-
nals, Proc. IEEE Military COmm. Conf. (MILCOM) (2004) 218224doi:
10.1109/MILCOM.2004.1493272.
- [5] R. P. G. McNeil, M. Kataoka, C. J. B. Ford, C. H. W. Barnes, D. Anderson,
235 G. A. C. Jones, I. Farrer, D. A. Ritchie, On-demand single-electron transfer
between distant quantum dots, Nature 477 (2011) 43–442. doi:10.1038/
477414a.
- [6] G. Fève, A. Mahé, J. M. Berroir, T. Kontos, B. Plaçais, D. C. Glattli,
A. Cavanna, B. Etienne, Y. Jin, An on-demand coherent single-electron
240 source, Science 316 (2007) 1169–1172. doi:10.1126/science.1141243.

- [7] N. Ubbelohde, F. Hohls, V. Kashcheyevs, T. Wagner, L. Fricke, B. Kastner, K. Pierz, H. W. Schumacher, R. J. Haug, Partitioning of on-demand electron pairs, *Nature Nanotech* 10 (2015) 46–49. doi:10.1038/nnano.2014.275.
- 245 [8] J. Dubois, T. Jullien, F. Portier, P. Roche, A. Cavanna, Y. Jin, W. Wegscheider, P. Roulleau, D. C. Glattli, Minimal-excitation states for electron quantum optics using levitons, *Nature* 502 (2013) 659–663. doi:10.1038/nature12713.
- [9] T. Jullien, P. Roulleau, B. Roche, A. Cavanna, Y. Jin, D. Glattli, Quantum
250 tomography of an electron, *Nature* 514 (2014) 603–607. doi:10.1038/nature13821.
- [10] L. S. Levitov, H. Lee, G. Lesovik, Electron counting statistics and coherent states of electric current, *J. Math. Phys.* 37 (1996) 4845. doi:http://dx.doi.org/10.1063/1.531672.
- 255 [11] D. C. Glattli, P. Roulleau, patent wo2016124841 a1.
- [12] H. Farès, D. C. Glattli, Y. Louet, J. Palicot, P. Roulleau, C. Moy, Power spectrum density of single side band CPM using lorentzian frequency pulses, submitted to *IEEE Wireless Communication Letters* (2017).
- [13] H. E. Rowe, V. K. Prabhu, Power spectrum of a digital frequency-
260 modulation signal, *The Bell System Technical Journal* 54 (1975) 10951125. doi:10.1002/j.1538-7305.1975.tb02884.x.
- [14] E. Perrins, M. Rice, Reduced-complexity approach to iterative detection of coded soqpsk, *IEEE Trans. on Comm.* 55 (2007) 13541362. doi:10.1109/TCOMM.2007.900614.
- 265 [15] H. Farès, D. C. Glattli, Y. Louet, C. Moy, J. Palicot, P. Roulleau, New binary single side band CPM, *Proc. IEEE International Conference on Telecommunications (ICT)* (2017).