



HAL
open science

A flexible metamodel architecture for optimal design of Hybrid Renewable Energy Systems (HRES) – Case study of a stand-alone HRES for a factory in tropical island

Anastasia Roth, Marianne Boix, Vincent Gerbaud, Ludovic Montastruc, Philippe Etur

► To cite this version:

Anastasia Roth, Marianne Boix, Vincent Gerbaud, Ludovic Montastruc, Philippe Etur. A flexible metamodel architecture for optimal design of Hybrid Renewable Energy Systems (HRES) – Case study of a stand-alone HRES for a factory in tropical island. *Journal of Cleaner Production*, 2019, 223, pp.214-225. 10.1016/j.jclepro.2019.03.095 . hal-02082922

HAL Id: hal-02082922

<https://hal.science/hal-02082922>

Submitted on 7 May 2020

HAL is a multi-disciplinary open access archive for the deposit and dissemination of scientific research documents, whether they are published or not. The documents may come from teaching and research institutions in France or abroad, or from public or private research centers.

L'archive ouverte pluridisciplinaire **HAL**, est destinée au dépôt et à la diffusion de documents scientifiques de niveau recherche, publiés ou non, émanant des établissements d'enseignement et de recherche français ou étrangers, des laboratoires publics ou privés.



OATAO is an open access repository that collects the work of Toulouse researchers and makes it freely available over the web where possible

This is an author's version published in: <http://oatao.univ-toulouse.fr/23523>

Official URL : <https://doi.org/10.1016/j.jclepro.2019.03.095>

To cite this version :

Roth, Anastasia^{ORCID} and Boix, Marianne^{ORCID} and Gerbaud, Vincent^{ORCID} and Montastruc, Ludovic^{ORCID} and Etur, Philippe *A flexible metamodel architecture for optimal design of Hybrid Renewable Energy Systems (HRES) – Case study of a stand-alone HRES for a factory in tropical island.* (2019) *Journal of Cleaner Production*, 223. 214-225. ISSN 0959-6526

Any correspondence concerning this service should be sent to the repository administrator: tech-oatao@listes-diff.inp-toulouse.fr

A flexible metamodel architecture for optimal design of Hybrid Renewable Energy Systems (HRES) – Case study of a stand-alone HRES for a factory in tropical island

Anastasia Roth^{a, b}, Marianne Boix^{a, *}, Vincent Gerbaud^a, Ludovic Montastruc^a,
Philippe Etur^b

^a Laboratoire de Génie Chimique, Université de Toulouse, CNRS, INPT, UPS, Toulouse, France

^b VALOREM, 213 Cours Victor Hugo, Begles, France

Keywords:

Hybrid renewable energy system
Grassroots design
Metamodel
Optimization

The energy sector is mutating with an increasing share of renewable energy. Renewable energy developers are facing new challenges, in particular sizing systems that combine multiple production sources and storage devices to match demand. Accordingly, this paper proposes a flexible metamodel architecture and a C++ software implementation for the grassroots design of Hybrid Renewable Energy System (HRES). The metamodel enables one to build optimization problem formulated as a Mixed Integer Linear Problem (MILP) with a tailor made objective function to find the optimal size of HRES. The flexibility of the metamodel lies in its ability to handle many hybrid system configurations for three common types of usages of HRES, either for onsite demand, remote demand or a combination. It is demonstrated with two specific case studies, a stand alone HRES composed of PV panels, battery set, and a diesel generator; and a factory in a tropical island. This paper contributes to a better adoption of cleaner production systems since it provides to decision makers a tool for HRES assessment.

1. Introduction

It has been scientifically proven the anthropic origin of the current global warming is undisputed (Cook et al., 2013). Some recent reports suggest that improving energy efficiency could help significantly to maintain the warming to 1.5 °C above pre industrial levels is a target set by the COP21 held in Paris in 2015 (Grubler et al., 2018). One way to reach this goal is to develop innovative solutions towards a more efficient use of renewable energies. Consequently, the energy sector undergoes some important mutations to adapt to this situation by switching from a centralized model to a decentralized one. This fosters new demands that must be met with optimization tools, flexible enough to cope with any system configurations. Following the supply chain analysis of Garcia and You (2015), the French electricity grid qualifies as a centralized model where a few huge power plants are spread over the country to produce energy and a big energy distribution network transports energy toward the final consumer. On the

contrary, a decentralized model can be described as multiple small power plants producing energy transported in local grid toward local consumers. A decentralized model is deemed more resilient to large failure since the power production is multiple.

In this perspective, the design of Hybrid Renewable Energy System (HRES) has a leverage effect in the development of decentralized production facilities. A HRES can be defined as a combination of renewable and conventional energy sources. As a guideline, Fig. 1 describes the different usage configurations of a HRES considered in this work. Typically, energy consumption can be remote (case 1 Fig. 1), on site with stand alone systems (case 2 Fig. 1), or both with grid connected systems (case 3 Fig. 1). When consumption is remote, the electricity produced is entirely injected to the grid and transported toward the final consumer. In this case, optimization techniques are not necessary to size the system (dashed line box in Fig. 1), because the aim is to produce and inject as much as possible on the grid, and limitations arise only from available investment, location and existing regulation. For the on site consumption case 2, optimization tools are needed and undersizing or curtailing of the renewable production system is mandatory since energy surplus cannot be evacuated, implying the

* Corresponding author.

E-mail address: marianne.boix@ensiacet.fr (M. Boix).

Nomenclature

P_{prodPV}	Raw power from PV [W] float	n	Year
$P_{prodcurPV}$	Net power from PV [W] float	N	Life duration of the project
$E_{prodTotPV}$	Total amount of net energy produced with PV panels per year [Wh] float	$P_{unitPVSouth}$	Production time series for one module South exposed [W]
$Nb_{PVSouth}$	Number of PV modules south exposed – integer	$P_{unitPVNorth}$	Production time series for one module North exposed [W]
$Nb_{PVNorth}$	Number of PV modules north exposed – integer	$Nb_{maxPVSouth}$	Number of maximum PV South exposed
P_{inst}	PV rated power [W] float	$Nb_{maxPVNorth}$	Number of maximum PV North exposed
P_{curPV}	Power curtailment of PV panels [W] float	$\eta_{Transfo}$	PV Transformer yield if needed
$CapaU$	Storage useful capacity [Wh] float	η_{conv}	PV Converter yield
$Capa$	Storage capacity [Wh] float	$E_{stoInit}$	Initialization parameter of BESS
P_{rated}	Nominal power of storage capacity [W] float	η_{chBat}	BESS charging yield
P_{sto}	Power output of the BESS [W] float	η_{chConv}	BESS discharging yield
E_{sto}	Energy stored [Wh] float	$CapaU_{max}$	Maximum storage useful capacity for BESS [Wh]
E_{stoTot}	Total amount of energy exchanged through BESS per year [Wh] float	DOD	Depth of discharge
$P_{stoDisch}$	Power in discharge of the BESS [W] float	P_{rated}	Rated power of BESS [W]
P_{stoCh}	Power in charge of the BESS [W] float	$P_{maxDischConv}$	Rated power in discharge for bidirectional converter for BESS [W]
P_{bat}	Power from BESS before transformer and converter [W] float	$P_{maxChConv}$	Rated power in charge for bidirectional converter for BESS [W]
y1	Binary to prevent $P_{stoDisch}$ and P_{stoCh} coexist – binary	$P_{geMaxLimit}$	Maximum limit of maximum power delivered by DG [W]
P_{ge}	Power from DG [W] float	<i>SwitchingPeriod</i>	Vector of index of time t corresponding of a switching period (year, month, week)
P_{geMax}	Maximum DG power output [W] float	Nb_{period}	Number of desired period over the year
E_{geTot}	Total amount of energy produced with DG per year [Wh] float	Tol_{Pmoy}	Mean Diesel Generator power tolerance
y2	Binary to stop and start DG – binary	$Nb_{startMax}$	Maximum DG starting over a period
y3	Binary to count DG starting – binary	$fuelPrice$	DG starting count over desired period [€/L]
y4	Binary to count DG stopping – binary	$DG_{consumption}$	Value of fuel price [L/Wh]
y5	Binary to prevent y3 and y4 coexist – binary	P_{conso}	Consumed power [W]
Nb_{start}	DG starting count over desired period – Integer	$CAPEX_{PV}$	CAPEX of PV module [€/W]
$Operating_{cost}$	Cost of DG operation due to fuel consumption [€/float]	W_p	Watt peak of a PV module [W]
CAPEX	CAPEX of the project [€] float	$CAPEX_{capabat}$	CAPEX of BESS in function of storage capacity [€/Wh]
OPEX	OPEX of the project [€] float	$CAPEX_{pratedbat}$	CAPEX of BESS in function of rated power [€/W]
TLCC	Total Life Cycle Cost [€] float	$CAPEX_{DG}$	CAPEX of DG [€/W]
t	Time [h]	$OPEX_{PV}$	OPEX of PV module [€/W]
dt	Time step [h]	$OPEX_{bat}$	OPEX of BESS [€/Wh]
T	Time higher than t	$OPEX_{DG}$	OPEX of DG [€/W]
H	Time horizon	i	Internal Rate of Return (IRT)

use of an additional system (eg: diesel generator, grid connection) to meet the capacity demand. Finally, case 3 merges cases 1 and 2 and it consists in producing and consuming electricity on site, injecting electricity surplus to the grid and taking electricity from the grid in the case of unmatched demand.

For the last two cases, optimization techniques should be used since the HRES requires energy production sizing and management. Indeed, the production curve needs to match the load curve set by the demand, which is not straightforward with the high degree of intermittency of renewable energy. Two key challenges then arise: to design appropriately the capacity of the Energy Storage Systems (ESS) and the production system, to find a suitable energy management strategy to match the production and load curves within the constraints. In reality, both challenges are linked to some extent since the better the management strategy is, the smaller the ESS needs to be. On the contrary, the smaller the ESS is, the harder it will be to find the appropriate management strategy.

As it can be seen on Fig. 1, the problem as a whole is modular since several hybrid configurations can be conceived of and HRES can be used for different purposes. Renewable energy developers facing these issues need flexible tools. In our sense flexibility must

meet the following requirements: ability to model any HRES configuration for the three type of demands, possibility for the user to solve the optimization problem while he can define its own objective function, in the context of grassroots design.

In this paper, after a literature overview on HRES design methods and tools, we discuss a specific case study consisting in sizing a stand alone PV/battery/diesel HRES for a textile factory (Section 3). Above the specific HRES configuration of the case study we adopt a macroscopic point of view to propose a generic meta model of HRES (Section 4) which is the key toward the need for flexibility as we discuss and define above. The last section displays results of an imaginary case study to investigate the influence of battery cost and the results of the factory case study. Finally, this paper contributes to the adoption of cleaner production since it offers a tool to facilitate decision making on opportunities to develop HRES. According to recent studies and reports, the use of renewable energies can provide a “host of benefits to society” (Ellabban et al., 2014). Indeed, compared to non renewable energy sources, the implementation of HRES allows to:

Reduce carbon dioxide emissions,

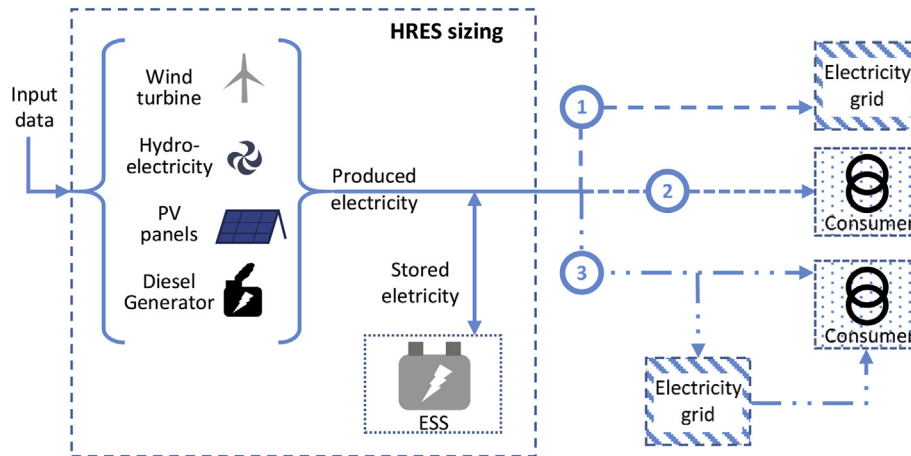

Fig. 1. A Hybrid Renewable Energy System representation and three types of matching energy demand.

Create local environmental and health benefits,
Facilitate energy access particularly in rural areas
Diversify the portfolio of energy technologies and resources
Increase potential employment activities.

To develop methodologies that can help the development of HRES by minimizing their cost can improve sustainable development locally. Besides, the case study takes place in a tropical island where the energy mix is often highly dependent on fossil fuel; the proposal of a HRES is an effective cleaner production in terms of fossil fuel usage.

2. Literature overview

The design of HRES has been largely studied over the past few years by several approaches. Literature is full of papers about the subject and are about:

Sizing techniques: these studies focuses on techniques to size properly the different elements composing a HRES (Ferrari et al., 2018). They are carried out with respect to the equipment depending on the seasonal effects (Giallanza et al., 2018). Some papers also deals with multi objective approach (Eriksson and Gray, 2019). For an extended literature on sizing techniques the reader can refer to several paper reviews (Al falahi et al., 2017; Singh et al., 2016; Tezer et al., 2017),

Optimization models: The goal is to find an optimal allocation of equipment satisfying constraints in time, size or use. Some studies opt for novel optimization techniques (Derakhshan et al., 2016; Eteiba et al., 2018; Fodhil et al., 2019; Gan et al., 2016; González et al., 2016). Especially, novel optimization techniques are of heuristic kind, which means that they are based on rules that need to be defined. For instance, for a PV/battery/diesel HRES rules for energy management strategy need to be specified in order to cover all possibility. The main issue with that kind of techniques is that the set of rules is case dependent which means that if one retrieves the battery one need to change the energy management strategy so redefine which are all the possibilities and so redefine entirely the set of rules. One can also cite a multi period optimization model by using a P graph model for the design of HRES (Aviso et al., 2017). Other studies deal with more classical optimization methodologies for example based on a MILP model (Atia and Yamada, 2016; Rigo Mariani et al., 2017; Scheubel et al., 2017).

Life cycle assessment approaches: they aim at evaluating environmental impacts of HRES over their life span (Theodosiou et al., 2015).

At last, many papers deal with case studies thanks to ready to use software such as the well known HOMER pro used in (Fodhil et al., 2019; Halabi and Mekhilef, 2018; Izadyar et al., 2016; Yilmaz and Dincer, 2017). Sinha and Chandel (2014) reviewed existing softwares for HRES sizing listed in Table 1 including HOMER.

Most of these software do not use optimization techniques, so they are likely to give under optimal results. Moreover, some softwares are no longer updated and used. Among the most used, HOMER pro is a simulation software without optimization capability, developed by the National Renewable Energy Laboratory (NREL) in USA. It has the advantage to be connected to popular databases regarding meteorology, technical aspects and consumption data. Therefore, users can get results in a simple and quick way without the need and time to specify many input data. However, users cannot fully control on the calculations, especially hypotheses implicitly done on input data, models of physical elements, calculation process and are limited to predefined indicators like Net Present Value (NPV), Levelized Cost Of Energy (LCOE) ... In spite of HOMER is a ready to use tool, decision makers feel limited to dig deeper into solutions. For instance adding a new constraint on grid utilization is not possible in HOMER, while with our metamodel one can add whatever mathematical constraints needed.

Eltamaly and Mohamed (2014) proposed an alternative simulation software, coded in FORTRAN, based on deterministic heuristic. Not able to perform optimization, the user is nevertheless able to find a HRES size through iterating simulations, which can take a long time and results are likely to be under optimal. Gan et al. (2015) introduce a GUI and a simulation model for sizing PV/Wind/Diesel Generator/Battery HRES. The simulation model is developed for a single HRES configuration. Mokheimer et al. (2013) introduce an algorithm to optimize the sizing of Wind/Solar/Reverse osmosis HRES and show that obtained results are similar to the one obtain with HOMER. Guinot (2013), developed the ODYSSEY platform, carrying out a multiobjective optimization with the help of a Genetic Algorithm (GA) running over a simulation model based on heuristics. Its strength lies in the accuracy of physical elements that can be described, when using a GA based solver, with non linear models: ageing of Batteries, hydrogen storage behavior, PV panel model, etc ... But, GA have several disadvantages. For instance, it is

Table 1
Existing software for sizing HRES.

Software	Optimization technics	Licence
HOMER By NREL (USA)	NO	Free
RETScreen By Ministry of Natural Resources (Canada)	NO	Free Demo
iHOGA by University of Zaragoza (Spain)	YES	Pro (Priced) Edu (free)
INSEL By University of Oldenburg (Germany)	NO	Priced
TRNSYS By University of Wisconsin And Colorado (USA)	NO	Priced
iGRHYSO(Spain)	YES	
HYBRIDS	NO	Priced
RAPSIM By University Energy Research Institute (Australia)	NO	Priced
SOMES By Utrecht University (Netherlands)	YES	
SOLSTOR By Sandia National Laboratory (USA)	YES	
HySim By Sandia National Laboratory (USA)	NO	No longer update
HybSim By Sandia National Laboratory (USA)	NO	No longer used
IPSYS	NO	
HySys (Spain)	NO	
Dymola/Modelica By Fraunhofer Institute for Solar Energy (Germany)	NO	
ARES by Cardiff School of engineering (UK)	NO	No longer available
SOLSIM (Germany)	NO	No longer available
ODYSSEY	YES	Priced

known that GA solutions are time consuming and that are sensitive to penalty function used when constraints are not satisfied.

In terms of flexibility as we defined it, all the approaches above are configuration dependent, cannot address all three problem cases, [Guinot \(2013\)](#) excepted, and cannot customize easily the objective function. In this paper, we start by describing a configuration dependent case study. The model of the case study is just used as an example and is not the main contribution of the paper. The novelty lies in the metamodelization which consist of a generic metamodel of an HRES. It describes with generic concepts what an HRES is and for what purposed is it used. The configuration dependent case study previously presented is split and classified into the metamodel according to the generic concepts. Thus, it allows to formulate optimization models for the grassroots design of HRES. Thus, the metamodelization give the needed flexibility (as define in introduction) to its C++ implementation.

The contributions in the literature all introduce models for specific HRES (for instance PV/battery/diesel ([Yilmaz and Dincer, 2017](#))). Therefore, they can only be used for the specific HRES they study. The power of our metamodel is to offer the possibility to cover all kind of HRES configuration and provide a capitalization frame to build flexible tools. Despite we present a specific model in our paper for the sake of illustration, one can implement in our metamodel other mathematical models to cover its purpose.

Our model consists in a MILP implemented within our meta model. Despite the inherent complexity of HRES, model structure is size dependent so integer variables are necessary; for instance revenue rate from power injection to grid can be size dependent. In addition, by considering energy balance in HRES, it is possible to formulate a linear model. Such an approximate modelling is nevertheless sufficient when one focuses on grassroots design of HRES, as we do in this paper. It could be used in early stages of HRES development for exploring opportune alternatives. Fast calculation are then mandatory and model accuracy is important but not a top priority and MILP formulation is acceptable.

In summary, the novelty of the paper is the proposition of a metamodel, which offers a generic and conceptual representation of HRES. By implementing this metamodel, the resulting tool is flexible in the sense defined in introduction section. We choose to implement the metamodel with MILP models inside for easy for mulations and fast calculations.

3. Case study

3.1. Case study presentation

The case study is about sizing a stand alone HRES for a textile factory on a tropical Island, referred as a type 2 problem in [Fig. 1](#). The HRES is equipped with PV panel (PV), Diesel Generator (DG) and Battery Energy Storage System (BESS). PV are installed on the rooftop, hence the number of PV that can be installed is limited. The case study aims at using our modular approach to find how many PV to install, what is the optimal storage capacity as well as the optimal rated power of the DG with a minimum cost. [Fig. 2](#) illustrates the problem. The main input data is the solar radiation time series and the consumption time series.

3.2. Optimization model

The general formulation of the MILP optimization problem is as follow:

$$\left\{ \begin{array}{l} \text{minc}(\vec{x}, \vec{y}, \vec{z}) \\ \text{s.t.} \\ \vec{h}(\vec{x}, \vec{y}, \vec{z}) = \mathbf{0} \\ \vec{g}(\vec{x}, \vec{y}, \vec{z}) \leq \mathbf{0} \\ \vec{x} \in \mathbb{R} \\ \vec{z} \in \mathbb{N} \\ \vec{y} \in \{0, 1\} \end{array} \right. \quad (1)$$

Integers and binaries are managed as continuous variables. The nomenclature section displays the variables and the parameters of the model. The objective of the current MILP model is to minimize the total life cycle cost of the system: *TLCC*, by variation of the rated power of the different components, under technical and economic constraints.

3.2.1. Time modelling

The case study is calculated over a one year time horizon with 8760 time steps *dt* of 1 h since it exhibits enough features of the time variation imposed of HRES.

To calculate the profitability of the project, *n* is the year flow while *N* is the total life duration of the project. In the study, we process the calculation over a year and we duplicate for every year

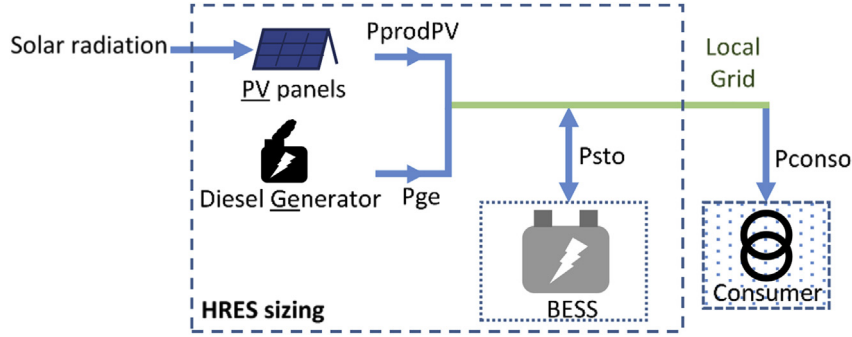

Fig. 2. Case study stand-alone HRES scheme.

after. So, variables, like OPEX, that should vary over n are kept constant from one year to the other.

3.2.2. PV panels

Solar radiation is taken from the Meteonorm database (Meteotest, n.d.) and Pvsyst software (Pvsyst S.A, n.d.) is used to convert solar radiation into time series of produced electricity for one PV module. Table 2 gives the PV parameter values.

Production of electricity from PV is as follow

$$\forall t \in 1; H, P_{prodPV}(t) = Nb_{PVSouth} \cdot P_{unitPVSouth}(t) + Nb_{PVNorth} \cdot P_{unitPVNorth}(t)$$

$$\forall t \in 1; H, P_{prodcurPV}(t) = (P_{prodPV}(t) - P_{curPV}(t)) \cdot \eta_{Transfo} \cdot \eta_{conv}$$

And the total amount of energy produced from PV panels is

$$E_{prodTotPV} = \sum_{t=1}^H P_{prodPV}(t)$$

$$E_{prodcurTotPV} = \sum_{t=1}^H P_{prodcurPV}(t)$$

Moreover, it is necessary to add a constraint to prevent curtailment power exceeding PV production:

$$\forall t \in 1; H, 0 \leq P_{curPV}(t) \leq P_{prodPV}(t)$$

Finally, the number of PV is constrained by the surface available for PV installation on the roof top.

$$0 \leq Nb_{PVSouth} \leq Nb_{maxPVSouth}$$

$$0 \leq Nb_{PVNorth} \leq Nb_{maxPVNorth}$$

Table 2
PV parameter values.

Parameters	Value	Unit
$P_{unitPVSouth}$ $P_{unitPVNorth}$	From Meteonorm and Pvsyst	[W]
$\eta_{Transfo}$	1	
η_{conv}	0.94	
W_p	290	[W]
$Nb_{maxPVSouth}$	3738	
$Nb_{maxPVNorth}$	3738	

Table 3
Battery Energy Storage System parameter values.

Parameters	Value	Unit
$P_{maxChConv}$	1e18	[W]
$P_{maxDischConv}$	1e18	[W]
η_{chBat}	0.97	
η_{chConv}	0.96	
$\eta_{dischBat}$	0.97	
$\eta_{dischConv}$	0.96	
DOD	0.9	
$CapaU_{max}$	1e20	[Wh]

3.2.3. Battery Energy Storage System

Table 3 gives the BESS parameter values. Converters and battery yields are assumed to be constant. The useful storage capacity $CapaU_{max}$ and limitation in power output of the bidirectional converter.

$P_{maxChConv}$ and $P_{maxDischConv}$ are set at very large values so that calculation is not hindered by them. Storage capacity is free but will likely be bounded in some studies since its cost impacts negatively the objective function. The storage power output is ≤ 0 when BESS is in discharge and ≥ 0 when BESS is in charge. Discharge power and charge power are stored in separate variables:

$$\forall t \in 1; H, P_{sto}(t) = P_{stoDisch}(t) + P_{stoCh}(t)$$

By adding the two following constraints, $P_{stoDisch}(t)$ and $P_{stoCh}(t)$ cannot coexist.

$$\forall t \in 1; H, 0 \leq P_{stoDisch}(t) \leq y1(t) \cdot P_{maxDischConv}$$

$$\forall t \in 1; H, (1 - y1(t)) \cdot P_{maxChConv} \leq P_{stoCh}(t) \leq 0$$

Power from battery before converter is as follows

$$\forall t \in 1; H, P_{bat}(t) = \eta_{chBat} \cdot \eta_{chConv} \cdot P_{stoCh}(t) + \eta_{dischBat} \cdot \eta_{dischConv} \cdot P_{stoDisch}(t)$$

And energy stored in battery is calculated from the following equation

$$\forall t \in 1; H, E_{sto}(t) = E_{sto}(t-1) + P_{bat}(t) \cdot dt$$

With $E_{sto}(0)$ being free from initialization constraints so that the solver can choose by itself the initial value.

Constraints over power, energy and capacity of BESS are as follows

$$\forall t \in 1; H, P_{rated} \leq P_{bat}(t) \leq P_{rated}$$

$CapaU \quad DOD.Capa$

$\forall t \in 1;H, CapaU \leq E_{sto}(t) \leq Capa$

$0 \leq CapaU \leq CapaU_{max}$

The battery for the case study is a C/2 battery, so:

$Capa \quad 2.P_{rated}$

3.2.4. Diesel Generator

Table 4 gives the DG parameter values. Power output from DG is as follow

$$\forall t \in 1;H, \quad 0 \leq P_{ge}(t) \leq P_{geMax} \cdot y2(t) \quad (2)$$

With

$$0 \leq P_{geMax} \leq P_{geMaxLimit}$$

And total amount of energy produced with DG is

$$E_{geTot} = \sum_{t=1}^H P_{ge}(t)$$

Constraints are added to count start and stop events of DG:

$$\forall t \in 1;H, \quad y3(t) = y4(t) - y2(t) - y2(t - 1)$$

$$\forall t \in 1;H, \quad 0 \leq y3(t) \leq y5(t)$$

$$\forall t \in 1;H, \quad 0 \leq y4(t) \leq 1 - y5(t)$$

For the solver in equation (2), choosing $y2(t) = 1$ and $P_{ge}(t) = 0$ is equivalent to $y2(t) = 0$ and $P_{ge}(t) = 0$. As this can cause wrong value in $y3$ and consequently in DG starting count, we add the following constraints to solve the issue:

$$\forall t \in 1;H, \quad 0 \leq y3(t) \leq P_{ge}(t)$$

DG suppliers request to DG users not to exceed a specific amount of starting per day to prevent damage on the DG. Those switching constraints are as follows

$$\forall T \in 1;Nb_{period}, \quad Nb_{start}(T) = \sum_{t=SwitchingPeriod(T-1)+1}^{SwitchingPeriod(T)+1} y3(t)$$

$$\forall T \in 1;Nb_{period}, \quad 0 \leq Nb_{start}(T) \leq Nb_{startMax}$$

Calculation of operating cost of DG due to fuel consumption is done with the following equation:

Table 4
DG parameter values.

Parameters	Value	Unit
$P_{geMaxLimit}$	1.2e6	[W]
Tol_{pmoy}	0.3	
$Nb_{startMax}$	5 per day	
$fuel_{price}$	0.72	[€/L]
$DG_{consumption}$	0.3e-3	[L/Wh]

$$Operating_{cost} = \sum_{t=1}^{8760} fuel_{price} \cdot DG_{consumption} \cdot P_{ge} \cdot dt$$

3.2.5. Consumer

Because the factory case study takes place in a tropical area, where there are no significant seasonal effects of the climate, and because the factory activity is almost identical over the year, we modelled the load curve as follows: the consumption was measured and recorded on site during a month, then we take the average hourly values to build a day time series. It was replicated 365 times and multiplied by 0 for each day off to make a one year time series of consumer power $P_{conso}(t)$.

The factory's activities has the particularity to start 1 h before sunrise and end 1 h after sunset. Thus, during this two time steps the PV panels can't provide energy so the system will need to use either the battery or the diesel generator. Moreover, the factory does not run every day so the load curve present some days without any consumption which can be challenging for the systems.

3.2.6. Grid

In compliance with Fig. 2 the grid is built to interconnect PV, BESS, DG and consumer:

$$\forall t \in 1;H, \quad P_{prodPV}(t) + P_{sto}(t) + P_{ge}(t) = P_{conso}(t)$$

3.2.7. Business plan

Table 5 gives the Business plan parameter values. CAPEX and OPEX are calculated as follows. OPEX varies over n but is identical from one year to another.

$$CAPEX = CAPEX_{pV} \cdot (Nb_{pVSouth} + Nb_{pVNorth}) \cdot W_p + CAPEX_{capaBat} \cdot Capa + CAPEX_{pratedBat} \cdot P_{rated} + CAPEX_{DG} \cdot P_{geMax}$$

$$OPEX(n) = OPEX_{pV} \cdot CAPEX_{pV} \cdot (Nb_{pVSouth} + Nb_{pVNorth}) \cdot W_p + OPEX_{bat} \cdot (CAPEX_{capaBat} \cdot Capa + CAPEX_{pratedBat} \cdot P_{rated}) + OPEX_{DG} \cdot CAPEX_{DG} \cdot P_{geMax}$$

The total life cycle cost of the project is then calculated

$$TLCC = CAPEX + \sum_{n=1}^N \frac{OPEX(n) + Operating_{cost}(n)}{(1+i)^n} \quad (3)$$

Table 5
Business Plan parameter values.

Parameters	Value	Unit
$CAPEX_{pV}$	0.8	[€/W]
$CAPEX_{capaBat}$	0.5	[€/Wh]
$CAPEX_{pratedBat}$	10% $CAPEX_{capaBat}$	[€/W]
$CAPEX_{DG}$	0.25	[€/W]
$OPEX_{pV}$	3% $CAPEX_{pV}$	[€/W]
$OPEX_{bat}$	4% $CAPEX_{capaBat}$	[€/Wh]
$OPEX_{DG}$	8% $CAPEX_{DG}$	[€/Wh]
i	0.8	
N	25	

NB: value are given by experts consultation.

3.2.8. Objective function

Regarding the general problem formulation applied to the stand alone HRES demand case 2 in Fig. 1, we minimize the TLCC of the project: $\min TLCC$. In this case, minimizing TLCC (equation (3)) is equivalent to minimizing LCOE since the general definition of LCOE is:

$LCOE = \frac{TLCC}{\text{Total amount of produced energy}}$. Usually, the total amount of produced energy is a variable so that the LCOE formula is non linear. But, in our case energy produced is equal to total consumed energy since the system is stand alone. Total consumed energy being known, minimizing LCOE is equivalent to minimizing TLCC. In the demand cases 1 and 3 of Fig. 1, the total energy produced is not equal to the total consumed energy, so LCOE is nonlinear. We focus our work on grassroots design and MILP models are suitable (as explain in I/B), therefore nonlinear formulation is not permitted and demand cases 1 and 3 are compliant with min TLCC only (equation (3)).

4. Architecture of a flexible metamodel and implementation

4.1. About the metamodel

In this section, the modelling methodology of HRES is made generic in terms of a metamodel and implemented in a flexible software. The software is designed with an object oriented approach and coded in C++. It is built as a native CPLEX based application by using CPLEX c++ API (IBM, n.d.). Otherwise, the software is able to read and write .mat file (Matlab matrix file) thanks to Matlab c++ API (MatWorks, n.d.). For the software development, we used CPLEX 12.8, Matlab version 2015b and Visual studio 2017.

4.2. Flexible metamodel

The object oriented metamodel architecture is sketched on Fig. 3 with help of UML2 language and is based on interconnected elements thanks to links described by object classes. For the sake of conciseness, methods and class attributes are not displayed on the figure. Classes are described hereafter:

SELECSYS: is the main program in charge of displaying the IHM and orchestrating the software operation.

GUI: is the Graphical User Interface.

Problem: the class has methods to import the configuration of the HRES, import user defined parameters, create elements of the problem, create link between element of the problem, build the objective function of the optimization problem, build the optimization model, solve the problem, extract results and finally export results.

Algorithm: even though a MILP based software is proposed, the class diagram is general enough to formulate problem with other classical optimization methods MINLP, QP, etc ...

Link: the class has the following attributes to define links – **ID** to identify the link, **IDElement i** to set which is the element at the input/output (i = 1 stand for input and i = 2 stand for output), **TypeElement i** to set the type of element at the input/output, **PortElement i** to set the port number link to the input/output – and 1 method to give the value of its attributes.

Element: The element class stores the name of the external file where parameters of the element are defined, read external files where element parameters are stored, builds own optimization model, gives results and writes it in an external file. The Element class has an attribute **Node** set by default to 0 and a child class Node Element that has specific methods to get decision variables of its connected element. In addition, **Node** attribute inherited from Element class is set at 1 in the Node Element class. This difference in Node value is needed to identify objects of the class Element and objects of the class Node Element.

The metamodel not only gives flexibility on problem formulation in terms of HRES structure but also on objective function definition. Indeed, all existing software listed on the literature survey have predefined objective function such as Net Present Value (NPV), Levelized Cost Of Energy (LCOE), IRT (Internal Rate of Return), etc ... Most of the time it is not possible for user to custom its own objective function. Yet, decision makers like to test several hypothesis or alternatives in order to make smart decisions. For instance they can have the need to design an HRES that minimize the PV curtailment, or the diesel generator starting, or the number of battery cycle, etc ... Those kind of objective function are not included in commercial software. The proposed software implementation is designed with a module to define a tailor made objective function. Depending on the blocs the user combines in its problem formulation, the software will list the available decision

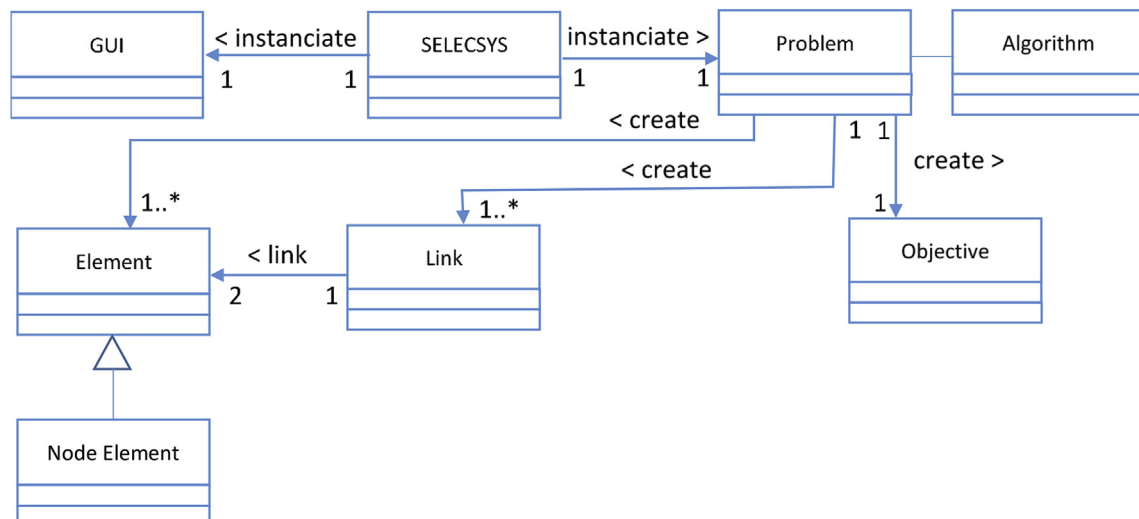

Fig. 3. The HRES flexible metamodel in UML2 class diagram.

variables and the user will have the possibility to combine it in an objective function equation with linear operators. Then, the software will generate an XML file that describes the user formulation for the objective function. Finally, the Objective class can store the XML objective data: the objective function formulation and the direction of the optimization (minimization or maximization). The Objective class has methods to build the objective function and to write the objective function value in an external file.

4.3. Element class diagram

The element class diagram is sketched on Fig. 4. Elements like PV, BESS or DG belong to the Element mother class and have their own variables, parameters, and equations. Electrical Grid is a special class belonging to the Node Element class which belongs itself to the Element class. It can handle any number and type of input and output and recover the output value of connected elements. Hence, Grid equations are defined as follow: sum of the input equal sum of the output. Given that, if there exists a Wind turbine bloc in the Elements library, it is possible to simply interchange PV bloc with the Wind turbine bloc and calculate a new configuration without redefining a complete optimization model.

By using this object oriented structure it is possible to formulate a MILP model for HRES sizing in a modular way. Node Element and Link classes are used to link Element one each other. The equations introduced in the previous section are classified and put in their respective Element classes. User specify which Element he want to use in its problem. Then, the main program build the corresponding MILP model by calling one by one the methods that build the model of each Element specified. In this way, it builds the complete optimization model.

Referring to Fig. 1 the demand case 1 problem is addressed when the user uses elements of production and storage if needed, plus Grid. Demand case 2 is tackled with elements of production and storage coupled with grid and consumer elements. Finally, for demand case 3, the user should use the same elements as for case 2 plus an electricity supplier element (not represented on Fig. 4 for the sake of conciseness).

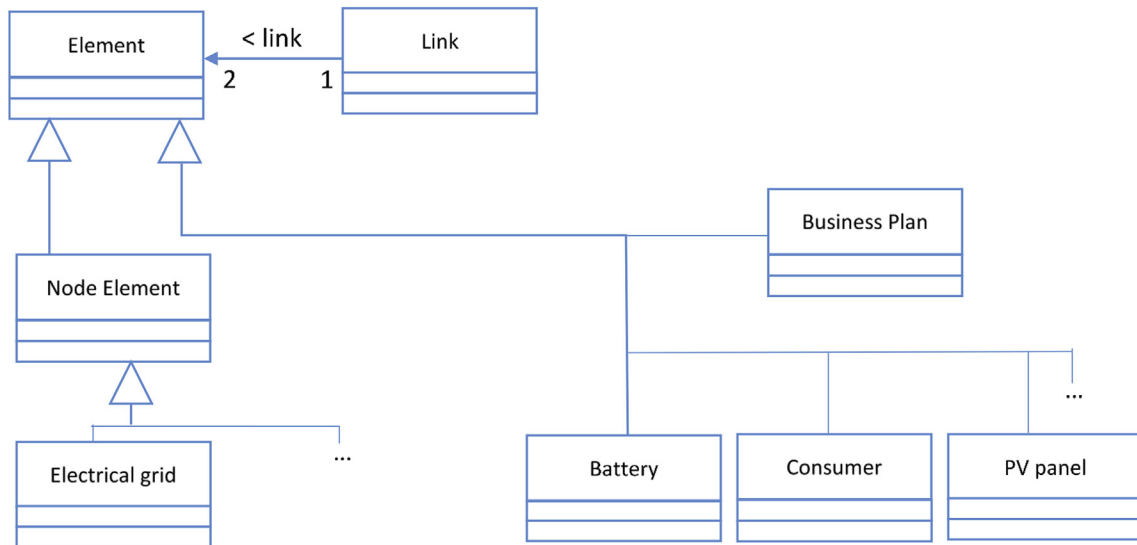

Fig. 4. HRES Element class diagram.

5. Results and discussion

This section is made of two parts: the first part (5.1 and 5.2) aim at performing a HRES sizing and a sensitivity analysis with respect to various consumption profile. We first present an imaginary case with a very low battery cost to force the solutions towards the use of batteries. Then we update the battery cost to a real twenty fold higher cost, which is closer to reality. The second part of the section aims at presenting the final sizing results of a real factory in tropical area. Several parameters related to consumption are varied, within a week span and, we consider that a year made of 52 weeks of 7 days (364 days).

5.1. Imaginary case: low battery cost

First of all, the model is tested in imaginary case when battery cost is low: $CAPEX_{capaBat} = 0.025 \text{ €/Wh}$. We make three scenarios to highlight the sensitivity of the model to the consumption time series, varying either the total amount of energy consumed per year and/or the daily consumed amount and/or the number of consecutive days of operation of the factory:

SC1: the total amount of energy consumed over the year is fixed at 665 MWh while the total amount of energy consumed over a day varies with the number of consecutive consumption days in the week. For this scenario, the initial consumption time series is divided by 3, 4, 5, 6 and 7 to create a new time series for cases of 3, 4, 5, 6 and 7 consecutive consumption days respectively. The total amount of consumed energy over a day varies from 4.263 MWh to 1.827 MWh.

SC2: the number of consecutive consumption days is fixed at 7. The total amount of energy consumed over the year and a day varies from 185 MWh to 665 MWh and from 0.508 MWh to 1.827 MWh respectively.

SC3: the total amount of energy consumption per day is fixed while the total amount of energy consumed over the year varies as well as the number of consecutive consumption days. In this scenario, the consumption time series of SC1 7 consecutive days is taken.

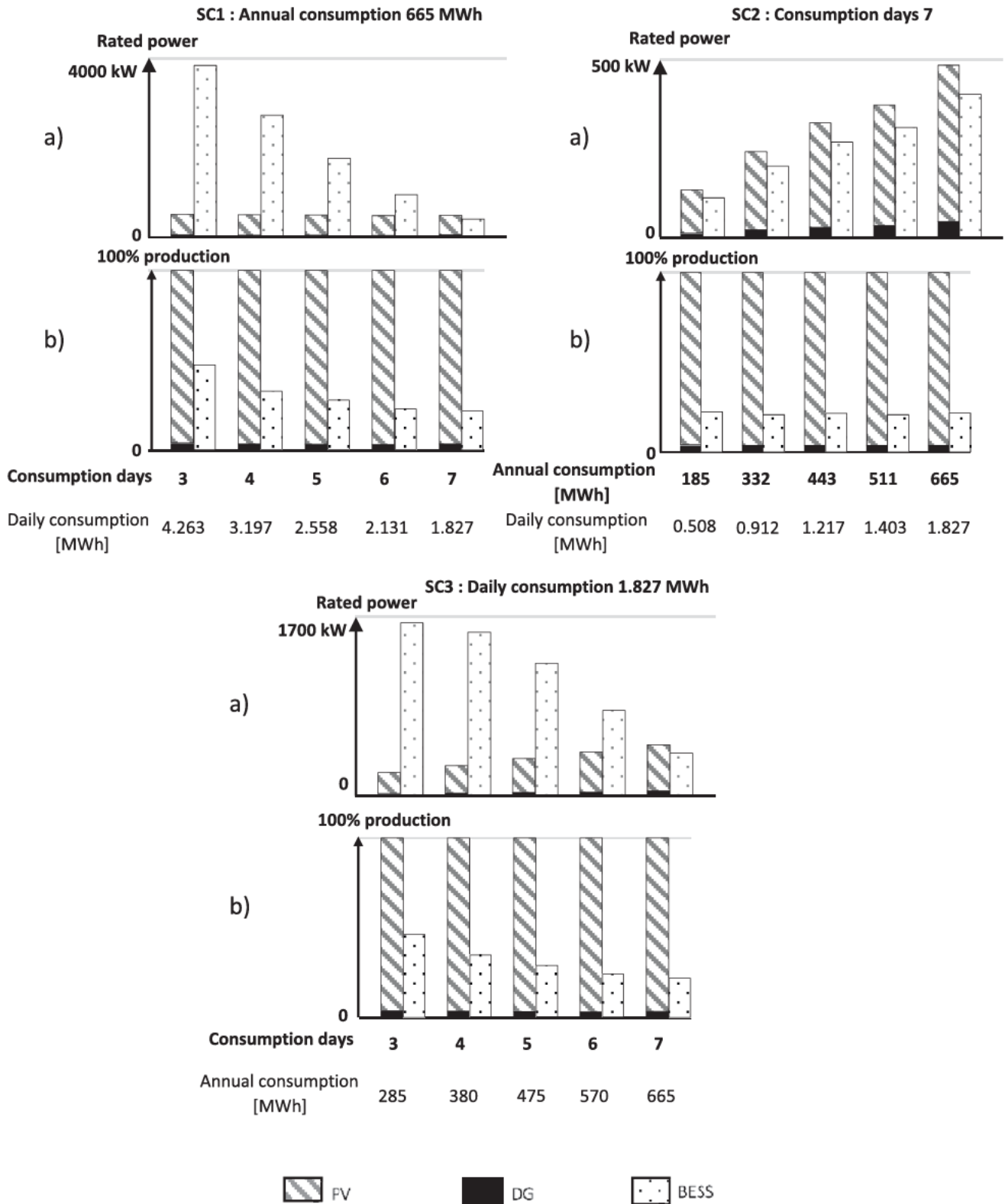

Fig. 5. Results of the imaginary case study: low battery cost.

SC1 and SC2 are created to validate the model on simple cases while SC3 is closer to reality since the factory load curve can be considered the same every week and we analyze the consequence of leaving some days off. The following discussions focus on the

overall trend of the results, therefore small variations inside the values are assumed to be not significant.

Results are displayed in Fig. 5 and the values of the bar graphs are given in appendix (Tables 8–11). In SC1, as the yearly demand is

constant while the demand inside a day decreases as the number of consecutive consumption days increases. Therefore, we expect smaller installations as this happens, and the HRES model rightfully suggests reducing the rated power of each element (SC1 top graph). The rated power of the battery decreases as the consecutive consumption days increase, because with less days off, the storage of energy produced by the PV and DG is less attractive. Also, the energy produced, either by PV or DG is consumed right away. The rated power and the production split (SC1 bottom graph) shows a major contribution of solar panels, which increases to the detriment of the generator use as the daily consumption drops. The battery is fed and its usage decreases for the same reason than its rated power.

In SC2, we keep the total number of active days but vary the daily demand. As the daily demand increases, PV and DG are solicited to produce more electricity, keep equal their splitting. The battery is also fed and used to meet the demand, while its contribution to the demand remains equal for all daily consumption values.

Finally, SC3 results confirm SC1 and SC2 analysis. As the daily demand is kept constant but the number of active days is increased, PV and DG are monitored to produce more energy. Besides with less days off the battery usage diminishes for the same reason than in SC1: energy produced is used to meet the increasing immediate demand rather than stored. It can also be seen that PV is more and more used since its weight is increasing in the production mix while the installed capacity of DG and the BESS are varying in the opposite direction. Actually, those two elements are competing since the more the battery is used the less the DG runs and the less it costs.

5.2. Real case: high battery cost

The same calculations are performed but now with more realistic battery cost: $CAPEX_{capaBat} = 0.5 \text{ €/Wh.}$, 20 times more expensive than earlier. For the sake of conciseness, only the results of the third scenario are sketched on Fig. 6. Overall, the trends observed in the last section are the same, with the direct consequence of a battery cost increase: as expected the installed battery is reduced, so much that it represents only 2% of the energy mix. This small battery is barely noticeable. Would it not be taken into account, the economic TLCC would be higher, by 0.0038% for the

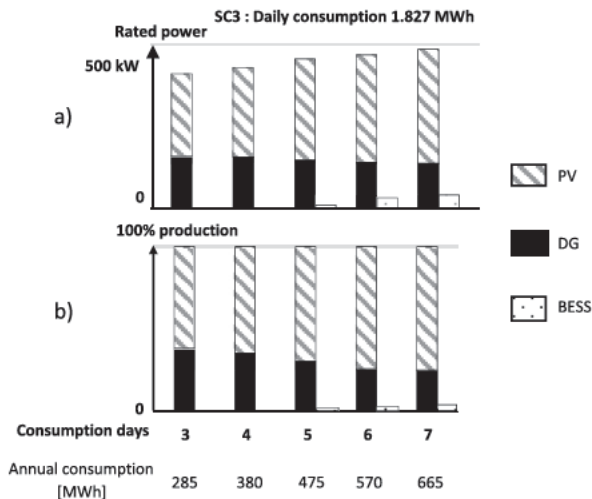

Fig. 6. Result of the case study with realistic high battery cost.

Table 6
TLCC gain with battery use.

Consumption days	TLCC gain by using battery
3	0%
4	0%
5	0.0013%
6	0.0038%
7	0.0039%

case with 6 days and daily consumption value 1.827 MWh. Table 6 gather the value of all the cases.

In mathematical terms, the battery allows to obtain a lower economic optimum, but the gain is small. We may remark, that this battery has been proposed thanks to the MILP formulation without any supplementary data or MINLP solving. Indeed, if we had to use a MINLP solver because the model would have been non linear, the branch and cut solving algorithm in use for MINLP problem is usually too rough to capture such small differences and the battery might not have been proposed in the solution.

5.3. The case study of a factory in tropical area

The objective of this section is to size the HRES for a small factory in tropical area that consumes 548 MWh over a year. The parameters are fixed at their values presented in section 2b. The load curve is original, built from on site recordings. The factory runs 6 days in the week and 1 day off. The main results are presented in Table 7 and Fig. 7 give an illustration of the resulting system. One can remark that there is more energy produced than consumed. The surplus remain in the battery at the end of the calculation.

Fig. 8 sketches the power split of April 6th 2017 to April 13th 2017 for illustration. Calculations were made on a computer with 4 threads, 8GO RAM and processor Intel Core I5, 7th generation cadenced at 2.5 GHz. The optimization procedure in CPLEX took 14 min 04 s.

On Fig. 8, the first graph superimposes consumption power and how it is matched. It also displays the PV power repartition between net power output, curtailment and storage. When black surface (Storage) is above the consumption curve it means that some PV production is stored, when the black surface is below the production curve it is because of the discharge of the battery.

According to the HRES solution we obtain (Table 7), despite more than a thousand PV panels, all oriented south, PV usage is not enough to meet the consumption demand and battery with diesel generator are used, especially early and late in the active day. That happens because of the variable sun availability during the day.

Table 7
Factory case study main variables values.

Variable	Value	Units
$E_{prodTotPV}$	564.1	[MWh]
$E_{prodcurTotPV}$	414.2	[MWh]
$E_{curTotPV}$	149.9	[MWh]
$Nb_{PVSouth}$	1112/1112	
$Nb_{PVNorth}$	0/1112	
$CapaU$	37.4	[kWh]
P_{rated}	18.7	[kW]
E_{stoTot}	11.8	[MWh]
P_{geMax}	144.7	[kW]
E_{geTot}	160.3	[MWh]
$Operating_{cost}$	34.6	[k€]
CAPEX	313.8	[k€]
OPEX	11.4	[k€]
TLCC	805.4	[k€]

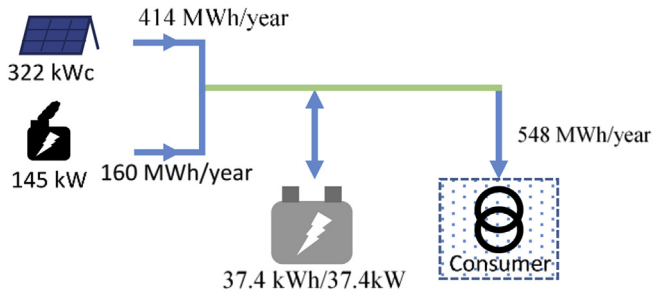

Fig. 7. Schema of the resulting HRES.

is positive, the battery is discharged to match partially the demand. When negative, the battery is charged by the PV panels. The battery energy curve shows that the battery starts the period displayed by being fully loaded at 37.43 kWh and ends also fully loaded. It is also never completely discharged with 3.74 kWh remaining at any time, which corresponds to the deadband of the battery.

6. Conclusion

Bibliography analyses has shown a lack of alternative to iterative solving HOMER software in HRES sizing tools while at the same time HRES developers must meet new demands requiring optimization. HOMER is the most used worldwide but is not adaptable to the many problems tackle by a renewable project developer. Bearing in mind the need for a flexible tool dealing with HRES sizing and focusing on grassroots design, we have proposed a new modular metamodel described with the help of UML2 and based on a MILP optimization model formulation to solve three kinds of usage problems, namely remote consumption through grid, on site consumption and mixed grid connected consumption. We have implemented it as a software and used it to solve several case studies. First two imaginary cases have shown the ability of the metamodel to represent and optimize HRES over a year time series, including PV panels and diesel generators and a small battery capacity. The MILP formulation was especially useful to find solutions with small battery capacity. We have noticed that the occurrence of battery and its consequent usage is strongly dependent on its cost. Finally, we have solved a real case study application of a small

Regarding PV power, it is much larger than demand in midday hours when the sun is high in the sky or when the day is off (day 7). Then, curtailment is important around midday for day 1–6 and for day 7, as an alternative storage in battery exists but remains low, as Table 7 and Fig. 8 show.

As explained in the previous section, because the battery cost is high, the storage capacity with battery is very small. For comparison it is equivalent to the battery implemented in electric cars. Battery is used marginally in comparison of the others elements. We have looked for another solution without battery and obtained a TLCC value equal to 808.3 k€, a 0.36% increase compared to the solution with battery. May be the project developer would not install the battery for a mere 0.36% gain. The second graph displays the battery power and energy during the seven days period. The battery power variation matches the one above. Here, when power

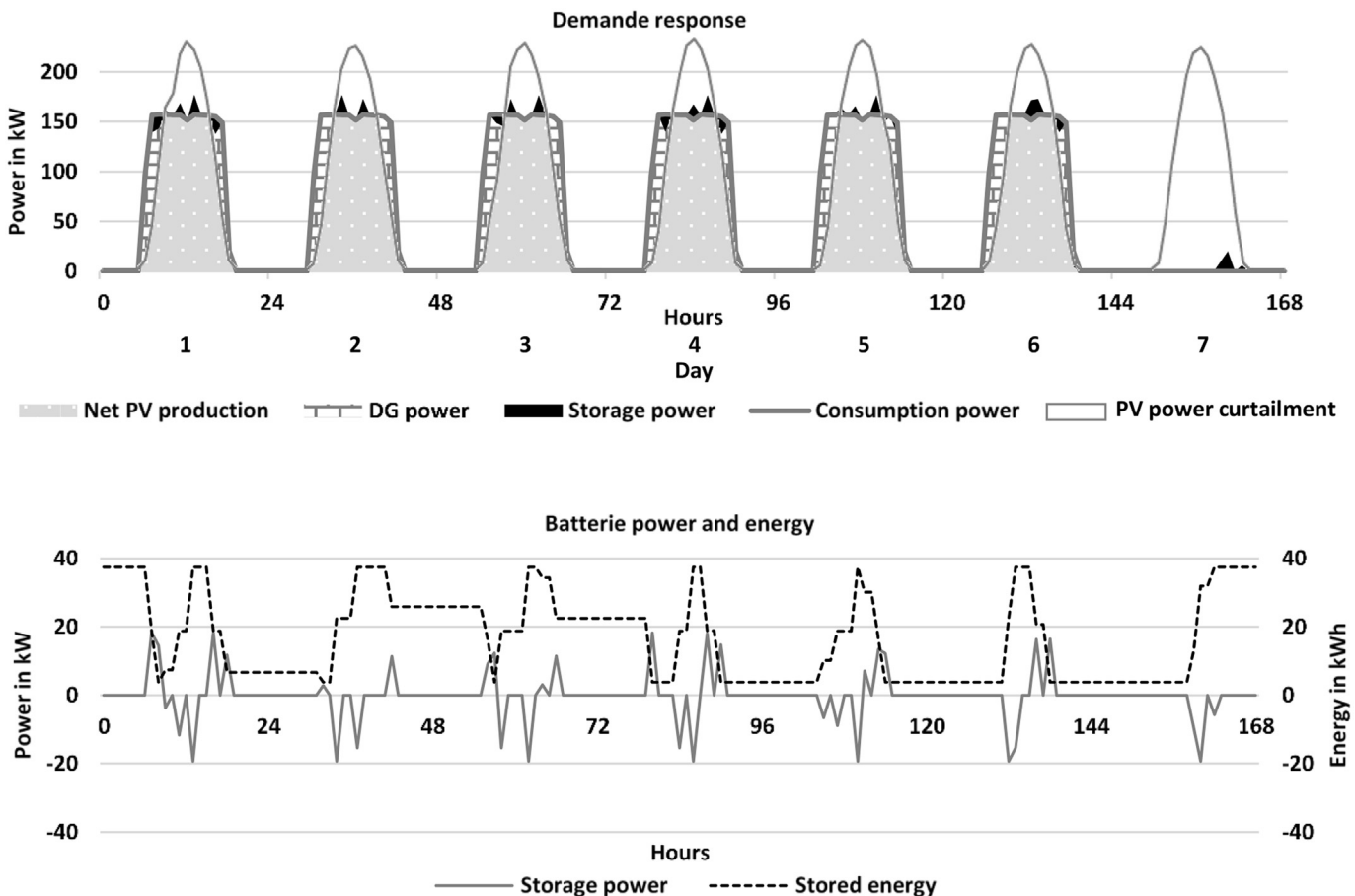

Fig. 8. Power curves of the factory case study.

factory in a tropical island. The results are useful for decision makers since it give elements for assessing the opportunities to develop such HRES. Those results can be presented to clients and are support for discussions and negotiations.

Our metamodel is flexible enough to be used for solving various problem from classical on site consumption (case 2 Fig. 1) to self use with partial injection (case 3 Fig. 1). Our metamodel can also be adapted to deal with financial trading and arbitrage on Spot electricity market. Moreover, it is possible to reformulate battery model by taking into account the ageing of the battery which is important for improving the business plan accuracy. Multi objective optimization can also be performed, especially by weighting the solutions based on technical and economic concern with environmental impact. Doing so ensure to put the solution back to its complex surrounding and tend to issue more flexible solutions. Finally, going further in the software development to make it competitive with HOMER is another perspective.

Appendix A. Supplementary data

Supplementary data to this article can be found online at <https://doi.org/10.1016/j.jclepro.2019.03.095>.

References

- Al-falahi, M.D.A., Jayasinghe, S.D.G., Enshaei, H., 2017. A review on recent size optimization methodologies for standalone solar and wind hybrid renewable energy system. *Energy Convers. Manag.* 143, 252–274. <https://doi.org/10.1016/j.enconman.2017.04.019>.
- Atia, R., Yamada, N., 2016. Sizing and analysis of renewable energy and battery systems in residential microgrids. *IEEE Trans. Smart Grid* 7, 1204–1213. <https://doi.org/10.1109/TSG.2016.2519541>.
- Aviso, K.B., Lee, J., Carlo, J., Royce, V., Okusa, J., Tan, R.R., 2017. A P-graph model for multi-period optimization of sustainable energy systems. *J. Clean. Prod.* 161, 1338–1351. <https://doi.org/10.1016/j.jclepro.2017.06.044>.
- Cook, J., Nuccitelli, D., Green, S.A., Richardson, M., 2013. Quantifying the consensus on anthropogenic global warming in the scientific literature. *Environ. Res. Lett.* 8, 024024. <https://doi.org/10.1088/1748-9326/8/2/024024>.
- Derakhshan, G., Shayanfar, H.A., Kazemi, A., 2016. Optimal design of solar PV-WT-SB based smart microgrid using NSHCSO. *Int. J. Hydrog. Energy* 41, 19947–19956. <https://doi.org/10.1016/j.ijhydene.2016.08.085>.
- Ellabban, O., Abu-rub, H., Blaabjerg, F., 2014. Renewable energy resources : current status, future prospects and their enabling technology. *Renew. Sustain. Energy Rev.* 39, 748–764. <https://doi.org/10.1016/j.rser.2014.07.113>.
- Eltamaly, A.M., Mohamed, M.A., 2014. A novel design and optimization software for autonomous PV/Wind/Battery Hybrid Power Systems. *Math. Probl. Eng.* 2014, 1–16. <https://doi.org/10.1155/2014/637174>.
- Eriksson, E.L.V., Gray, E.M., 2019. Optimization of renewable hybrid energy systems e A multi-objective approach. *Renew. Energy* 133, 971–999. <https://doi.org/10.1016/j.renene.2018.10.053>.
- Eteiba, M.B., Barakat, S., Samy, M.M., Ismael, W., 2018. Optimization of an off-grid PV/Biomass hybrid system with different battery technologies. *Sustain. Cities Soc* 40, 713–727. <https://doi.org/10.1016/j.scs.2018.01.012>.
- Ferrari, L., Bianchini, A., Galli, G., Ferrara, G., Antonio, E., 2018. Influence of actual component characteristics on the optimal energy mix of a photovoltaic-wind-diesel hybrid system for a remote off-grid application. *J. Clean. Prod.* 178, 206–219. <https://doi.org/10.1016/j.jclepro.2018.01.032>.
- Fodhil, F., Hamidat, A., Nadjemi, O., 2019. Potential , optimization and sensitivity analysis of photovoltaic-diesel-battery hybrid energy system for rural electricity in Algeria. *Energy* 169, 613–624. <https://doi.org/10.1016/j.energy.2018.12.049>.
- Gan, L.K., Shek, J.K.H., Mueller, M.A., 2016. Optimised operation of an off-grid hybrid wind-diesel-battery system using genetic algorithm. *Energy Convers. Manag.* 126, 446–462. <https://doi.org/10.1016/j.enconman.2016.07.062>.
- Gan, L.K., Shek, J.K.H., Mueller, M.A., 2015. Hybrid wind-photovoltaic-diesel-battery system sizing tool development using empirical approach, life-cycle cost and performance analysis: a case study in Scotland. *Energy Convers. Manag.* 106, 479–494. <https://doi.org/10.1016/j.enconman.2015.09.029>.
- García, D.J., You, F., 2015. Supply chain design and optimization: challenges and opportunities. *Comput. Chem. Eng.* 81, 153–170. <https://doi.org/10.1016/j.compchemeng.2015.03.015>.
- Giallanza, A., Porretto, M., Puma, G.L., Marannano, G., 2018. A sizing approach for stand-alone hybrid photovoltaic-wind-battery systems : a Sicilian case study. *J. Clean. Prod.* 199, 817–830. <https://doi.org/10.1016/j.jclepro.2018.07.223>.
- González, A., Riba, J.R., Rius, A., 2016. Combined heat and power design based on environmental and cost criteria. *Energy* 116, 922–932. <https://doi.org/10.1016/j.energy.2016.10.025>.
- Grubler, A., Wilson, C., Bento, N., Boza-Kiss, B., Krey, V., McCollum, D.L., Rao, N.D., Riahi, K., Rogelj, J., De Stercke, S., Cullen, J., Frank, S., Fricko, O., Guo, F., Gidden, M., Havlík, P., Huppmann, D., Kiesewetter, G., Rafaj, P., Schoepp, W., Valin, H., 2018. A low energy demand scenario for meeting the 1.5 °C target and sustainable development goals without negative emission technologies. *Nat. Energy* 3, 515–527. <https://doi.org/10.1038/s41560-018-0172-6>.
- Guinot, B., 2013. Evaluation multicritère des technologies de stockage couplées aux énergies renouvelables : conception et réalisation de la plateforme de simulation ODYSSEY pour l'optimisation du dimensionnement et de la gestion énergétique. Université de Grenoble, France. HAL Id : tel-00934515, version 2.
- Halabi, L.M., Mekhilef, S., 2018. Flexible hybrid renewable energy system design for a typical remote village located in tropical climate. *J. Clean. Prod.* 177, 908–924. <https://doi.org/10.1016/j.jclepro.2017.12.248>.
- IBM, n.d. CPLEX @ concert technology C++ API reference [WWW Document]. URL https://www.ibm.com/support/knowledgecenter/SS9UKU_12.7.0/com.ibm.cplex.zos.help/refcalliblelibrary/homepageCrefman.html. accessed 8.20.18.
- Izadyar, N., Ong, H.C., Chong, W.T., Mojumder, J.C., Leong, K.Y., 2016. Investigation of potential hybrid renewable energy at various rural areas in Malaysia. *J. Clean. Prod.* 139, 61–73. <https://doi.org/10.1016/j.jclepro.2016.07.167>.
- MatWorks, n.d. MATLAB API [WWW Document]. URL <https://fr.mathworks.com/help/matlab/programming-interfaces-for-external-languages.html>. accessed 3.7.19.
- Meteotest, n.d. Meteororm [WWW Document]. URL <http://www.meteororm.com/>. accessed 3.7.19.
- Mokheimer, E.M.A., Sahin, A.Z., Al-Sharafi, A., Ali, A.I., 2013. Modeling and optimization of hybrid wind-solar-powered reverse osmosis water desalination system in Saudi Arabia. *Energy Convers. Manag.* 75, 86–97. <https://doi.org/10.1016/j.enconman.2013.06.002>.
- PVsyst, S.A. PVsyst [WWW Document]. URL <http://www.pvsyst.com>. accessed 3.7.19.
- Rigo-Mariani, R., Sareni, B., Roboam, X., 2017. Fast power flow scheduling and sensitivity analysis for sizing a microgrid with storage. *Math. Comput. Simulat.* 131, 114–127. <https://doi.org/10.1016/j.matcom.2015.11.010>.
- Scheubel, C., Zipperle, T., Tzscheutschler, P., 2017. Modeling of industrial-scale hybrid renewable energy systems (HRES) the profitability of decentralized supply for industry. *Renew. Energy* 108, 52–63. <https://doi.org/10.1016/j.renene.2017.02.038>.
- Sinha, S., Chandel, S.S., 2014. Review of software tools for hybrid renewable energy systems. *Renew. Sustain. Energy Rev.* 32, 192–205. <https://doi.org/10.1016/j.rser.2014.01.035>.
- Singh, S., Singh, M., Kaushik, S.C., 2016. A review on optimization techniques for sizing of solar-wind hybrid energy systems. *Int. J. Green Energy* 13, 1564–1578. <https://doi.org/10.1080/15435075.2016.1207079>.
- Tezer, T., Yaman, R., Yaman, G., 2017. Evaluation of approaches used for optimization of stand-alone hybrid renewable energy systems. *Renew. Sustain. Energy Rev.* 73, 840–853. <https://doi.org/10.1016/j.rser.2017.01.118>.
- Theodosiou, G., Stylos, N., Koroneos, C., 2015. Integration of the environmental management aspect in the optimization of the design and planning of energy systems. *J. Clean. Prod.* 106, 576–593. <https://doi.org/10.1016/j.jclepro.2014.05.096>.
- Yilmaz, S., Dincer, F., 2017. Optimal design of hybrid PV-Diesel-Battery systems for isolated lands : a case study for Kilis , Turkey. *Renew. Sustain. Energy Rev.* 77, 344–352. <https://doi.org/10.1016/j.rser.2017.04.037>.