

Packaging Solution for SiC Power Modules with a Fail-to-Short Capability

APEC, Anaheim, USA



Ilyas DCHAR¹, Cyril BUTTAY^{2*}, Hervé MOREL²

¹SuperGrid Institute, Villeurbanne, France
²Laboratoire Ampère, Villeurbanne, France

21/3/2019

Outline

Introduction

Power Module Design & Manufacturing

Test of the Failure Mode

Conclusions



Outline

Introduction

Power Module Design & Manufacturing

Test of the Failure Mode

Conclusions



Fail-to-Short Packaging for HVDC Applications

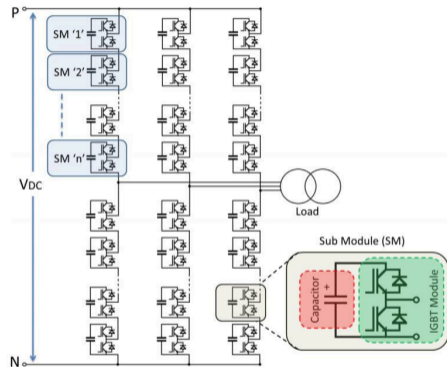

Source: I. Yaqub PhD thesis, 2015 [1]

HVDC Converters

- ▶ Rated at 100s kV
(ex 320 kV for France-Spain link)
 - ▶ Series of 100s of transistors
(800 for same converter)
 - ▶ Transistors fail randomly
 - ▶ Should not stop converter
 - ▶ Failed device turned to short circuit
- Need for Fail-To-Short Packaging

Fail-to-Short Packaging for HVDC Applications

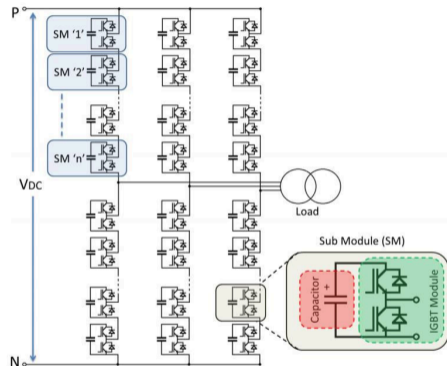

Source: I. Yaqub PhD thesis, 2015 [1]

HVDC Converters

- ▶ Rated at 100s kV
(ex 320 kV for France-Spain link)
 - ▶ Series of 100s of transistors
(800 for same converter)
 - ▶ Transistors fail randomly
 - ▶ Should not stop converter
 - ▶ Failed device turned to short circuit
- Need for Fail-To-Short Packaging

Fail-to-Short Packaging for HVDC Applications

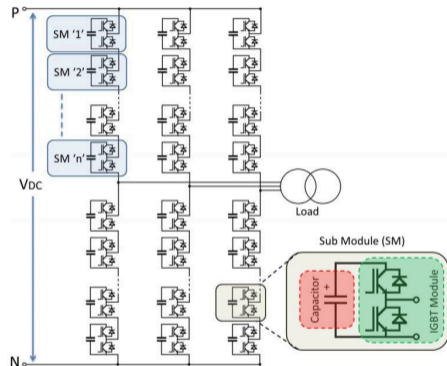

Source: I. Yaqub PhD thesis, 2015 [1]

HVDC Converters

- ▶ Rated at 100s kV
(ex 320 kV for France-Spain link)
- ▶ Series of 100s of transistors
(800 for same converter)
- ▶ Transistors fail randomly
 - ▶ Should not stop converter
 - ▶ Failed device turned to short circuit

→ Need for Fail-To-Short Packaging

Fail-to-Short Packaging for HVDC Applications

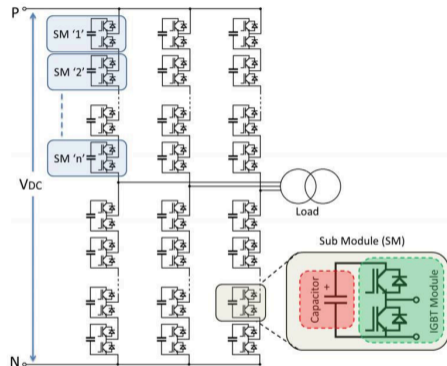

Source: I. Yaqcub PhD thesis, 2015 [1]

HVDC Converters

- ▶ Rated at 100s kV
(ex 320 kV for France-Spain link)
- ▶ Series of 100s of transistors
(800 for same converter)
- ▶ Transistors fail randomly
 - ▶ Should not stop converter
 - ▶ Failed device turned to short circuit

→ **Need for Fail-To-Short Packaging**

Fail-to-Short Packaging

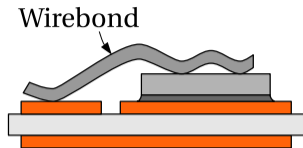

- ▶ Standard packaging: Fail-to-Open
- ▶ Wirebonds act as fuses or blown away
- ➔ Need for massive contacts

- ▶ “Press pack”-type packages introduced
- ▶ Initially for single die, now for multichip
- ▶ When failure occurs:
 - ▶ Temperature rises
 - ▶ Die and surrounding metal melt
 - ▶ They form a conductive area
 - ▶ Strong package contains explosion

Fail-to-Short Packaging

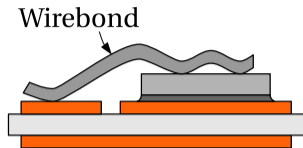

- ▶ Standard packaging: Fail-to-Open
- ▶ Wirebonds act as fuses or blown away
- ➔ Need for massive contacts

- ▶ “Press pack”-type packages introduced
- ▶ Initially for single die, now for multichip
- ▶ When failure occurs:
 - ▶ Temperature rises
 - ▶ Die and surrounding metal melt
 - ▶ They form a conductive area
 - ▶ Strong package contains explosion

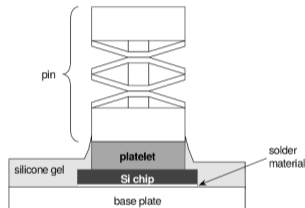

source: Gunturi, S. *et al.* Innovative Metal System for IGBT Press Pack Modules (ISPSD 2003) [2]

Fail-to-Short Packaging

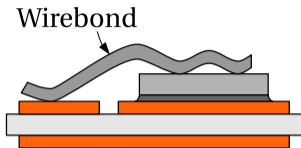

- ▶ Standard packaging: Fail-to-Open
- ▶ Wirebonds act as fuses or blown away
- Need for massive contacts

- ▶ “Press pack”-type packages introduced
- ▶ Initially for single die, now for multichip
- ▶ When failure occurs:
 - ▶ Temperature rises
 - ▶ Die and surrounding metal melt
 - ▶ They form a conductive area
 - ▶ Strong package contains explosion

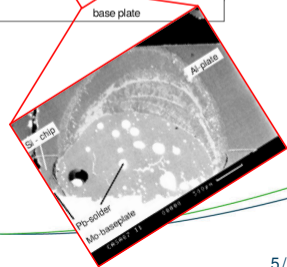
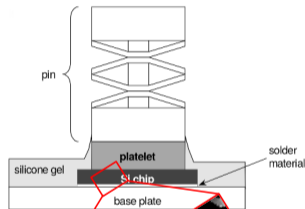

source: Gunturi, S. *et al.* Innovative Metal System for IGBT Press Pack Modules (ISPSD 2003) [2]

Fail-to-Short Packaging

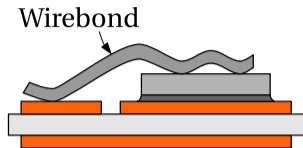

- ▶ Standard packaging: Fail-to-Open
- ▶ Wirebonds act as fuses or blown away
- Need for massive contacts

- ▶ “Press pack”-type packages introduced
- ▶ Initially for single die, now for multichip
- ▶ When failure occurs:
 - ▶ Temperature rises
 - ▶ Die and surrounding metal melt
 - ▶ They form a conductive area
 - ▶ Strong package contains explosion

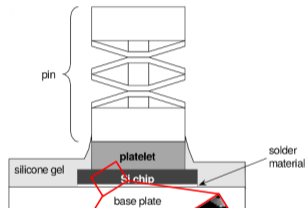

Is a FTS package Possible for SiC?

source: Gunturi, S. *et al.* Innovative Metal System for IGBT Press Pack Modules (ISPSD 2003) [2]

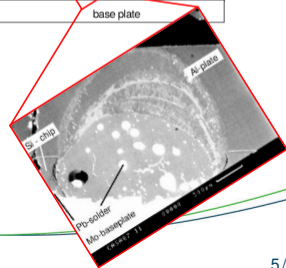

Previous investigations [3]

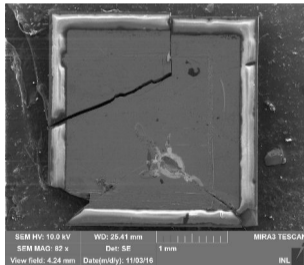

- ▶ Dies fracture because of failure
- ▶ SiC and metal remain separate
- ▶ Tiny metal filaments form

Previous investigations [3]

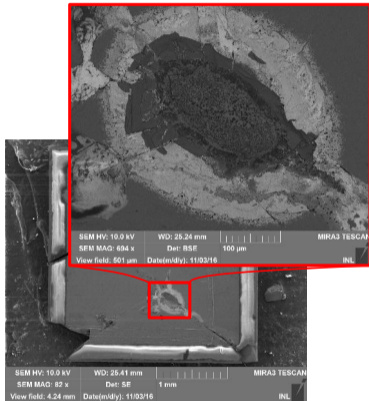

- ▶ Dies fracture because of failure
- ▶ SiC and metal remain separate
- ▶ Tiny metal filaments form

Previous investigations [3]

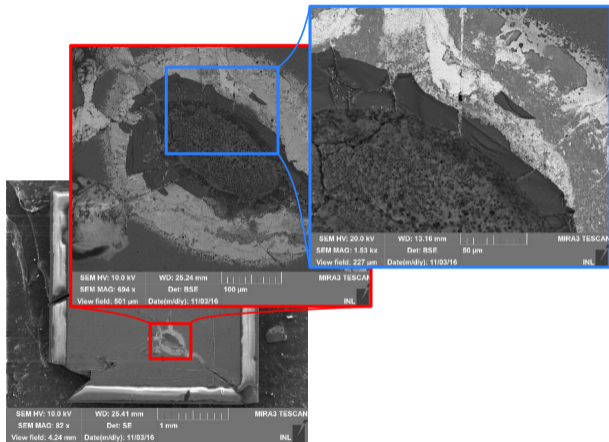

- ▶ Dies fracture because of failure
- ▶ SiC and metal remain separate
- ▶ Tiny metal filaments form

Previous investigations [3]

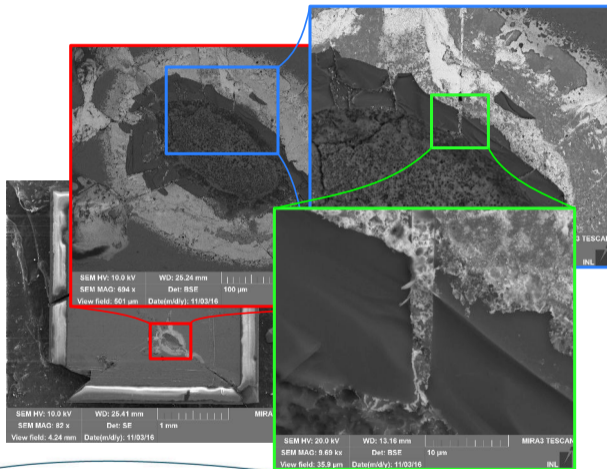

- ▶ Dies fracture because of failure
- ▶ SiC and metal remain separate
- ▶ Tiny metal filaments form

Previous investigations [3]

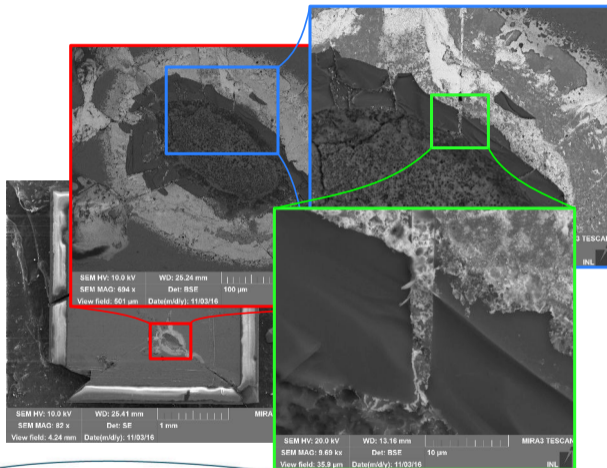

- ▶ Dies fracture because of failure
- ▶ SiC and metal remain separate
- ▶ Tiny metal filaments form

→ Fail-to-short behaviour possible with SiC

Outline

Introduction

Power Module Design & Manufacturing

Test of the Failure Mode

Conclusions



Module Structure

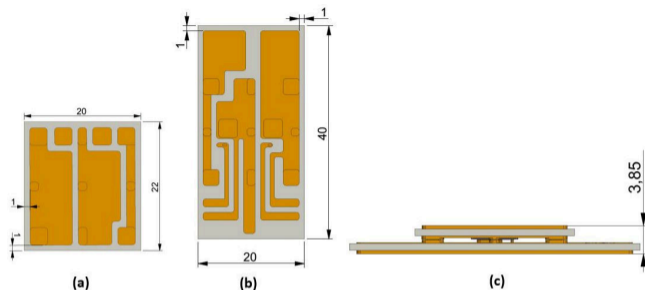

- ▶ **“Sandwich structure”**: massive interconnects
- ▶ **Silver sintering**: high temperature bonding
- ▶ **Salient features**: for topside contact with dies
- ▶ **Two SiC MOSFETs**: multi-chip module (half-bridge config.)

Preparation of the Substrates [4]

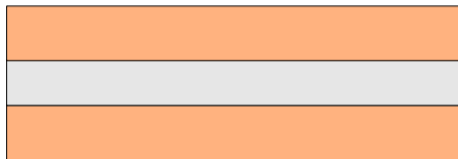

- ▶ DBC with 500 μm copper, 500 μm Al_2O_3
- ▶ Halfway-etching to form protrusions
- ▶ Second etching step to form circuit
- ▶ Ag finish

Preparation of the Substrates [4]



- ▶ DBC with 500 μm copper, 500 μm Al_2O_3
- ▶ Halfway-etching to form protrusions
- ▶ Second etching step to form circuit
- ▶ Ag finish

Preparation of the Substrates [4]

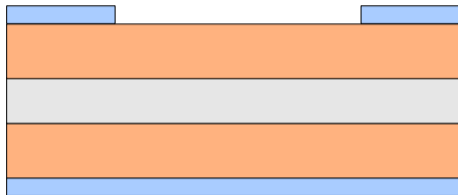

- ▶ DBC with 500 μm copper, 500 μm Al_2O_3
- ▶ Halfway-etching to form protrusions
- ▶ Second etching step to form circuit
- ▶ Ag finish

Preparation of the Substrates [4]

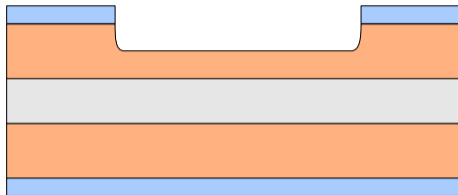

- ▶ DBC with 500 μm copper, 500 μm Al_2O_3
- ▶ Halfway-etching to form protrusions
- ▶ Second etching step to form circuit
- ▶ Ag finish

Preparation of the Substrates [4]

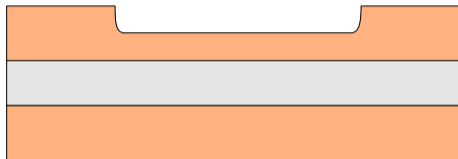

- ▶ DBC with 500 μm copper, 500 μm Al_2O_3
- ▶ Halfway-etching to form protrusions
- ▶ Second etching step to form circuit
- ▶ Ag finish



Preparation of the Substrates [4]

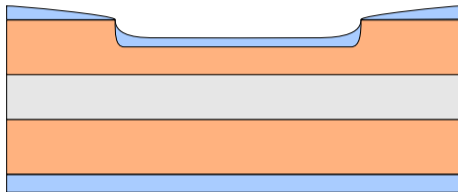

- ▶ DBC with 500 μm copper, 500 μm Al_2O_3
- ▶ Halfway-etching to form protrusions
- ▶ Second etching step to form circuit
- ▶ Ag finish

Preparation of the Substrates [4]

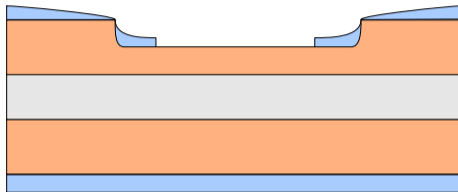

- ▶ DBC with 500 μm copper, 500 μm Al_2O_3
- ▶ Halfway-etching to form protrusions
- ▶ Second etching step to form circuit
- ▶ Ag finish

Preparation of the Substrates [4]

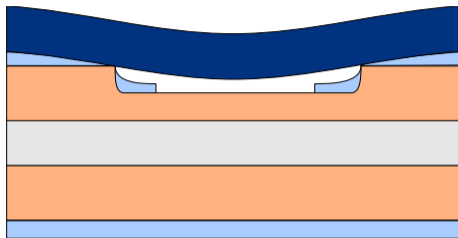

- ▶ DBC with 500 μm copper, 500 μm Al_2O_3
- ▶ Halfway-etching to form protrusions
- ▶ Second etching step to form circuit
- ▶ Ag finish

Preparation of the Substrates [4]

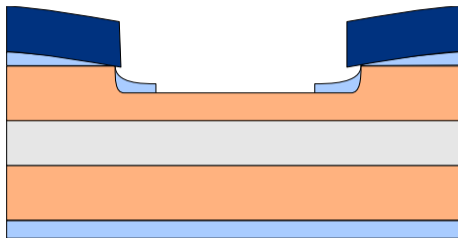

- ▶ DBC with 500 μm copper, 500 μm Al_2O_3
- ▶ Halfway-etching to form protrusions
- ▶ Second etching step to form circuit
- ▶ Ag finish

Preparation of the Substrates [4]

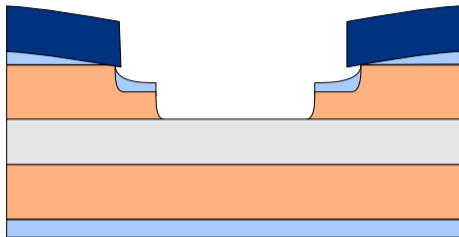

- ▶ DBC with 500 μm copper, 500 μm Al_2O_3
- ▶ Halfway-etching to form protrusions
- ▶ Second etching step to form circuit
- ▶ Ag finish

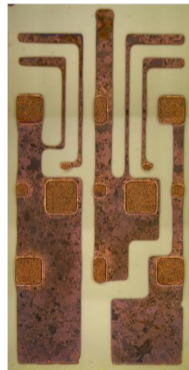

Preparation of the Substrates [4]

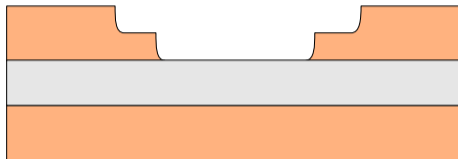

- ▶ DBC with 500 μm copper, 500 μm Al_2O_3
- ▶ Halfway-etching to form protrusions
- ▶ Second etching step to form circuit
- ▶ Ag finish

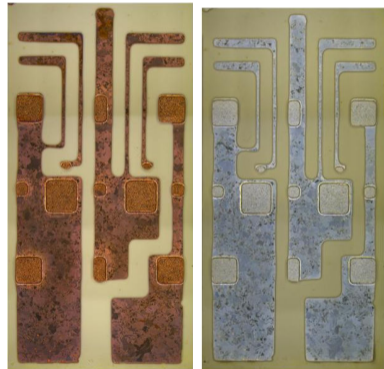

Power Module Assembly

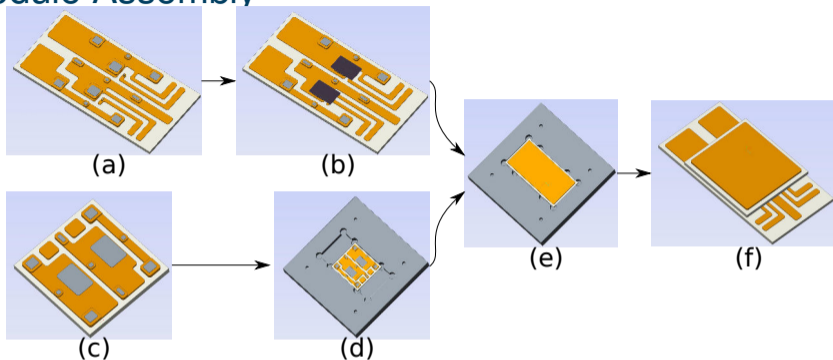

- ▶ Two sintering steps
- ▶ More details in paper and [4].

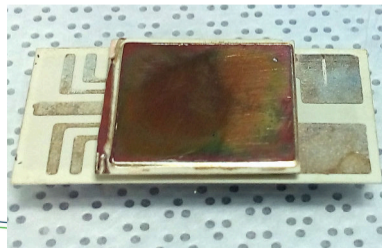

Electrical Validation

- ▶ 4 modules made (7 dies fonctionnal)
- ▶ 3 encapsulation schemes: none/Silicone gel/epoxy

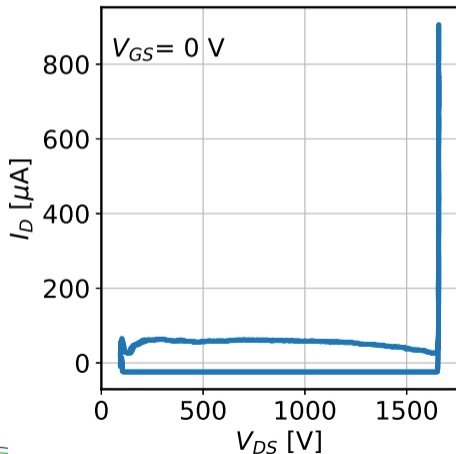
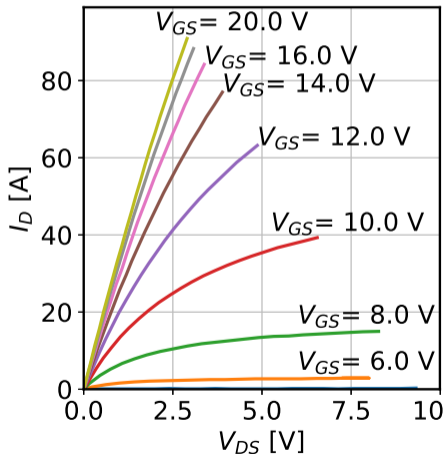

Outline

Introduction

Power Module Design & Manufacturing

Test of the Failure Mode

Conclusions



Test Setup – 1

Sample	Encapsulant	Clamp	Switch
Module A	None	Yes	MOS 1
			MOS 2
Module B	Silicone	Yes	MOS 1
			MOS 2
Module C	Epoxy	No	MOS 1
			MOS 2
Module D	Silicone	Yes	MOS 1
			–

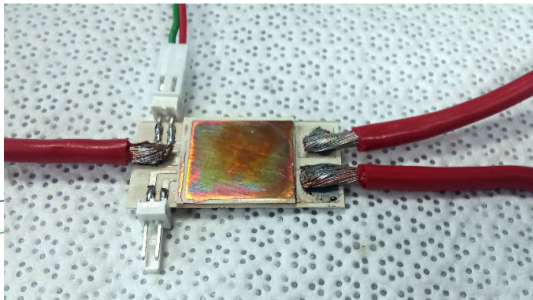
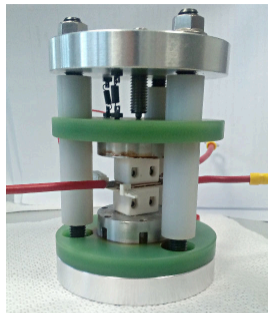

- ▶ Dies tested individually
- ▶ “Clamp” used for modules A, B and D
- ▶ MOS 2 of module D not connected

Test Setup – 2

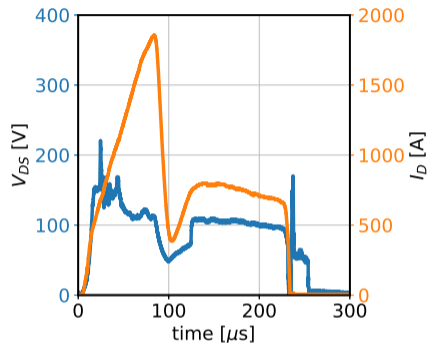
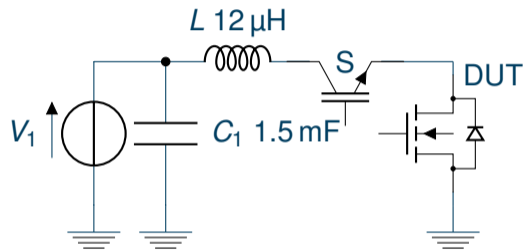

- ▶ Short circuit test for various energy levels (1 to 20 J)
- ▶ Inductance consequence of tester wiring
- ▶ Activation of protection switch S causes complex waveforms

Test Setup – 3

- ▶ After failure, modules are biased for 6 h at 10 A
- ▶ Short-circuit failure mode considered stable if $R_{final} < R_{init}$
- ▶ In some cases longer test, with 20 A

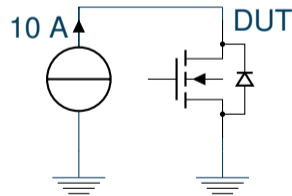
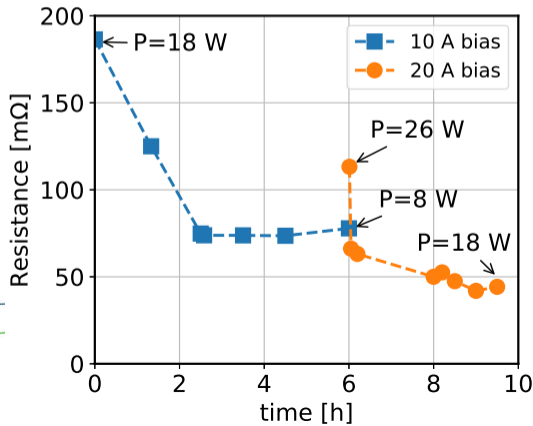

Results

	Encapsulant	Clamp	Switch	E [J]	R_{init} [mΩ]	R_{final} [mΩ]	Failure mode
A	None	Yes	MOS 1	–	186	77	SC
			MOS 2	8.8	201	128	SC
B	Silicone	Yes	MOS 1	20	165	120	SC
			MOS 2	1	188	167	SC
C	Epoxy	No	MOS 1	9.7	–	–	OC
			MOS 2	–	–	–	–
D	Silicone	Yes	MOS 1	2.24	180	158	SC
			–	–	–	–	–

- ▶ Module C separated during first test, causing open circuit
- ▶ All other modules exhibited stable short circuit

Analysis

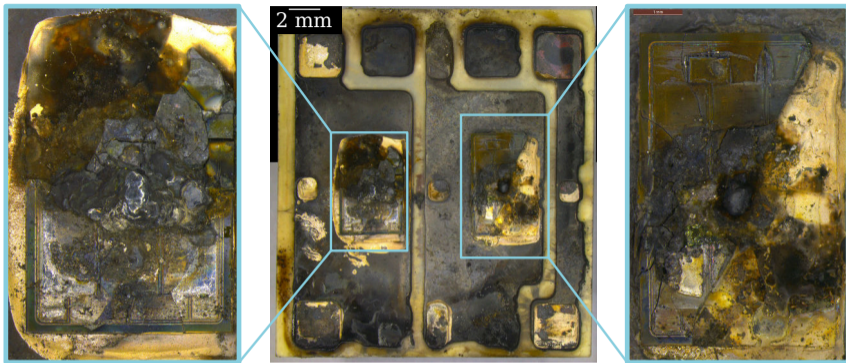

- ▶ Dies largely broken because of short circuit
- ▶ Change in color, oxydation of module
 - ▶ caused by high temperature during stability test
- ▶ Metal infiltrated in SiC cracks

Outline

Introduction

Power Module Design & Manufacturing

Test of the Failure Mode

Conclusions



Conclusions – 1

- ▶ Sandwich module proposed for fail-to-short behaviour
 - ▶ Relatively simple manufacturing process
 - ▶ Silver sintering as single bonding material
 - ▶ No degradation of SiC dies performance observed
 - ▶ Allows for dual-side cooling
- ▶ Short-circuit test up to 2000 A
 - ▶ “Clamped” modules were found to fail in short-circuit
 - ▶ Stable short-circuits observed after 6h
 - ▶ Final resistances 3-7 times higher than $R_{DS(on)}$ of SiC MOSFETs



Conclusions – 1

- ▶ Sandwich module proposed for fail-to-short behaviour
 - ▶ Relatively simple manufacturing process
 - ▶ Silver sintering as single bonding material
 - ▶ No degradation of SiC dies performance observed
 - ▶ Allows for dual-side cooling
- ▶ Short-circuit test up to 2000 A
 - ▶ “Clamped” modules were found to fail in short-circuit
 - ▶ Stable short-circuits observed after 6 h
 - ▶ Final resistances 3-7 times higher than R_{DSon} of SiC MOSFETs



Conclusions – 2

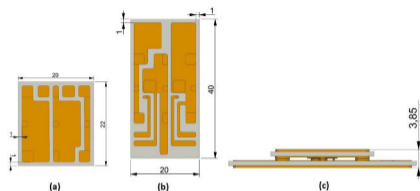



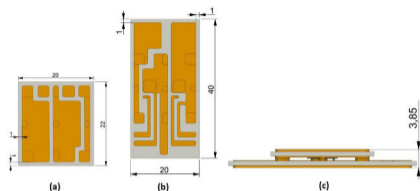

- ▶ Fail-to-Short behaviour with SiC dies requires:
 - ▶ To prevent the Ceramic tiles from separating
 - Need for strong mechanical clamp/frame
 - Soft encapsulant probably better for gases to escape
- ▶ To provide massive interconnects:
 - ▶ Wirebonds would act as fuses
 - ▶ Need to supply metal to fill the cracks in the dies
 - ▶ Heat dissipation at failure points help reducing the resistance

Conclusions – 2



- ▶ Fail-to-Short behaviour with SiC dies requires:
 - ▶ To prevent the Ceramic tiles from separating
 - Need for strong mechanical clamp/frame
 - Soft encapsulant probably better for gases to escape
- ▶ To provide massive interconnects:
 - ▶ Wirebonds would act as fuses
 - ▶ Need to supply metal to fill the cracks in the dies
 - ▶ Heat dissipation at failure points help reducing the resistance

Bibliography I

-  I. Yaqub, *Investigation into stable failure to short circuit in IGBT power modules*. Phd thesis, University of Nottingham, Nottingham, jul 2015.
-  S. Gunturi, J. Assal, D. Schneider, and S. Eicher, "Innovative Metal System for IGBT Press Pack Modules," in *Proceedings of the International Symposium on Power Systems and Devices (ISPSD)*, (Cambridge, UK), p. 4, Apr. 2003.
-  I. Dchar, C. Buttay, and H. Morel, "SiC power devices packaging with a short-circuit failure mode capability," *Microelectronics Reliability*, 2017.
-  C. Buttay, R. Riva, B. Allard, M.-L. Locatelli, and V. Bley, "Packaging with double-side cooling capability for SiC devices, based on silver sintering," in *44th Annual Conference of the IEEE Industrial Electronics Society (IECON 2018)*, Proceedings of the 44th Annual Conference of the IEEE Industrial Electronics Society (IECON 2018), (Washington, United States), IEEE, Oct. 2018.

Thank you for your attention

<https://www.supergrid-institute.com>

This work was supported by a grant overseen by the French National Research Agency (ANR) as part of the “Investissements d’Avenir” Program (ANE-ITE-002-01).

cyril.buttay@insa-lyon.fr