



HAL
open science

An accurate tracking control of an electropneumatic actuator

Xavier Brun, Daniel Thomasset, Eric Bideaux, Serge Scavarda

► **To cite this version:**

Xavier Brun, Daniel Thomasset, Eric Bideaux, Serge Scavarda. An accurate tracking control of an electropneumatic actuator. First Fluid Power Net International PhD Symposium, Sep 2000, Hamburg, Germany. hal-02066808

HAL Id: hal-02066808

<https://hal.science/hal-02066808v1>

Submitted on 2 Apr 2019

HAL is a multi-disciplinary open access archive for the deposit and dissemination of scientific research documents, whether they are published or not. The documents may come from teaching and research institutions in France or abroad, or from public or private research centers.

L'archive ouverte pluridisciplinaire **HAL**, est destinée au dépôt et à la diffusion de documents scientifiques de niveau recherche, publiés ou non, émanant des établissements d'enseignement et de recherche français ou étrangers, des laboratoires publics ou privés.

AN ACCURATE TRACKING CONTROL OF AN ELECTROPNEUMATIC ACTUATOR

Xavier BRUN, Daniel THOMASSET, Eric BIDEAUX and Serge SCAVARDA

Laboratoire d'Automatique Industrielle - INSA de Lyon

<http://www.insa-lyon.fr/Laboratoires/LAI/>

Bât 303, 20 Avenue Albert Einstein, 69621 Villeurbanne Cedex, France

Tel: (33) 4 72 43 88 81 Fax: (33) 4 72 43 85 35

Email: xavier.brun@lai.insa-lyon.fr

Synopsis: Due to low cost, clean working environments, linear power transfer facilities and good performance, pneumatic systems play a significant role in industrial processes. During the last twenty years, the parallel development of pneumatic systems and control theory has led to the implementation of modern control laws in pneumatic devices [Edge 1997].

The aim of this paper is to present and to compare experimental results for an electropneumatic positioning system. A classical linear control law with scheduling gains, established with the tangent linearized model, is compared with a more sophisticated nonlinear control law based on input-output linearization [Isidori 1989].

The tests are realised with two different admissible trajectories. The first one is a trajectory with a constant stage, which is usually used in robotic, to control painting system for example. The second one is a trajectory with constant acceleration and deceleration stages, often used for positioning systems which carry delicate loads or dangerous liquids in containers (as in the chemical industry). This choice of the trajectories has also to be related to a problem of sizing.

The experimental results are presented in terms of repeatability for each control law implemented on the same device: an in line electropneumatic servo-drive. The statistical comparisons between nonlinear and linear control laws are shown in terms of static error: mean value, standard deviation value, minimum and maximum values. The precision and the repeatability are deduced from these results. All these indicators are also processed during the dynamical stage.

The customer for choosing an appropriate control law for its desired specifications may use all these results.

Key words: Pneumatic, Nonlinear Control, Tracking.

1 INTRODUCTION

The system under consideration (figure 1) is a linear double acting electropneumatic servo-drive using a single rod (32/20 mm) with a stroke of 500 mm controlled by two three-way servo-distributors. A potentiometer gives the position. Velocity is obtained by analog derivation, and acceleration by numerical derivation. A pressure sensor is set in each chamber.

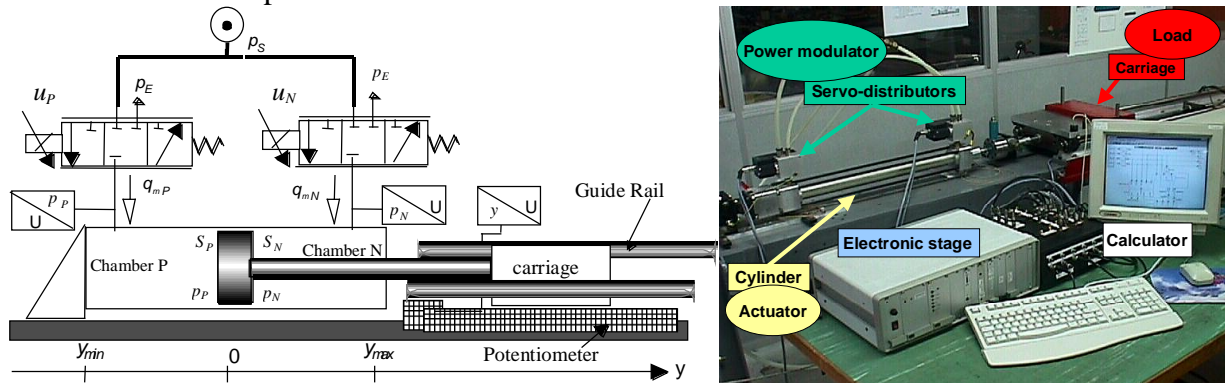

Figure 1: Experimental system.

2 ELECTROPNEUMATIC SYSTEM MODELLING

The electropneumatic system model can be obtained using classical assumptions [Shearer 1956]: the mass flow rate through a restriction, the pressure behaviour in a chamber with variable volume and the mechanical equation. The dynamic of the servo-distributors are neglected and his model can be reduced to a static one described by two relationships $q_{mP}(u_P, p_P)$ and $q_{mN}(u_N, p_N)$ between the mass flow rates q_{mP} and q_{mN} , the input voltages u_P and u_N , and the output pressures. Only one control is used with opposite sign on the two servo-distributors ($u_P = -u_N = u$).

$$\begin{cases} \frac{dp_P}{dt} = \frac{krT_s}{V_P(y)} \left[q_{mP}(u, p_P) - \frac{S_P}{rT_s} p_P v \right] \\ \frac{dp_N}{dt} = \frac{krT_s}{V_N(y)} \left[q_{mN}(-u, p_N) + \frac{S_N}{rT_s} p_N v \right] \\ \frac{dv}{dt} = \frac{1}{M} [S_P p_P - S_N p_N - f_v v - F_f - F_{ext}] \\ \frac{dy}{dt} = v \end{cases} \quad (1)$$

Where: $\begin{cases} V_P(y) = V_P(0) + S_P y \\ V_N(y) = V_N(0) - S_N y \end{cases}$ with $\begin{cases} V_P(0) = V_{DP} + S_P \frac{Stroke}{2} \\ V_N(0) = V_{DN} + S_N \frac{Stroke}{2} \end{cases}$ are the piping volumes of the chambers for

the zero position and $V_{D(P or N)}$ are dead volumes present on each extremities of the cylinder.

2.1 Nonlinear affine model

In the case of a nonlinear control synthesis, the theory based on Isidori works [Isidori 1989] requires that the model has to be a linear function of the control input, in order to obtain an explicit form of the control law. The model is called affine in the control. That is why the mass flow rate characterisation was approximated by polynomial function [Belgharbi 1999] affine in control (equation (2)) and the nonlinear affine model is then given by equation (3).

$$q_m(u, p) = j(p) + \gamma(p, \text{sgn}(\Gamma(u))) \Gamma(u) \quad (2)$$

$$\begin{cases} \frac{dp_P}{dt} = \frac{krT_s}{V_P(y)} \left[j(p_P) - \frac{S_P}{rT_s} p_P v \right] + \frac{krT_s}{V_P(y)} \gamma(p_P, \text{sgn}(\Gamma(u))) \Gamma(u) \\ \frac{dp_N}{dt} = \frac{krT_s}{V_N(y)} \left[j(p_N) + \frac{S_N}{rT_s} p_N v \right] - \frac{krT_s}{V_N(y)} \gamma(p_N, \text{sgn}(-\Gamma(u))) \Gamma(u) \\ \frac{dv}{dt} = \frac{1}{M} [S_P p_P - S_N p_N - f_v v - F_{ext}] \\ \frac{dy}{dt} = v \end{cases} \quad (3)$$

2.2 Linearized model

Defining the variations near the equilibrium set (equation 4); the linearized model obtained is given by equation 5.

$$\{dp_P = p_P - p_P^e, dp_N = p_N - p_N^e, dv = v - v^e, dy = y - y^e, du = u - u^e\} \quad (4)$$

$$\frac{d}{dt} \begin{bmatrix} dp_P \\ dp_N \\ dv \\ dy \end{bmatrix} = \begin{bmatrix} -\frac{1}{t_P^e} & 0 & -\frac{kp_P^e S_P}{V_P(y^e)} & 0 \\ 0 & -\frac{1}{t_N^e} & \frac{kp_N^e S_N}{V_N(y^e)} & 0 \\ \frac{S_P}{M} & -\frac{S_N}{M} & -\frac{f_v}{M} & 0 \\ 0 & 0 & 1 & 0 \end{bmatrix} \begin{bmatrix} dp_P \\ dp_N \\ dv \\ dy \end{bmatrix} + \begin{bmatrix} \frac{krT_S}{V_P(y^e)} G_{uP}^e \\ -\frac{krT_S}{V_N(y^e)} G_{uN}^e \\ 0 \\ 0 \end{bmatrix} du \quad (5)$$

With pressure time constants: $t_P^e = \frac{V_P(y^e)}{krT_S C_{pP}^e}$ and $t_N^e = \frac{V_N(y^e)}{krT_S C_{pN}^e}$ (6)

In the pneumatic field, the conventional position control law consists of position, velocity and acceleration feedback. Using acceleration feedback instead of pressures feedback or differential pressure feedback can be justified by the fact that an external perturbation force quickly influences acceleration.

To obtain a third order model with position, velocity and acceleration as state variables, Kellal et al [Kellal 1986] proposed to replace each time constant of each chamber by an average time constant t_m^e (geometric mean). Then the third order model is:

$$\frac{d}{dt} \begin{bmatrix} y \\ v \\ a \end{bmatrix} = \begin{bmatrix} 0 & 1 & 0 \\ 0 & 0 & 1 \\ 0 & -w_{ol}^2 & -2z_{ol}w_{ol} \end{bmatrix} \begin{bmatrix} y \\ v \\ a \end{bmatrix} + \begin{bmatrix} 0 \\ 0 \\ b \end{bmatrix} u \quad (7)$$

With $z_{ol} = \frac{1}{2w_{ol}} \left(\frac{1}{t_m^e} + \frac{f_v}{M} \right)$ and $b = \frac{krT_S}{M} \left[\frac{S_P G_{uP}^e}{V_P(y^e)} + \frac{S_N G_{uN}^e}{V_N(y^e)} \right]$ (8)

Where $w_{ol} = \sqrt{w_{cyl}^2 + \frac{f_v}{t_m^e M}}$ and $w_{cyl} = \sqrt{\frac{k}{M} \left(\frac{S_P^2 p_P^e}{V_P(y^e)} + \frac{S_N^2 p_N^e}{V_N(y^e)} \right)}$ (9)

3 PRINCIPLE OF TRACKING CONTROL

The two models 3 and 7 have a characteristic number associated to the output y equal to three. Then taking a triple integrator as reference model and using a first loop it is theoretically possible to obtain a perfect tracking result. If that is the case, the first feedback transforms models (3) or (7) in a triple integrator given by equation 10 (canonical Brunovsky form).

This transformation is local if the linearized tangent model is used, or global if nonlinear linearizing feedback is used [Isidori 1989]. On the following section the two methods are presented, studied and implemented in order to compare experimental results.

$$\dot{\underline{z}} = I_d \underline{z} + B_J j_c \quad \text{with } I_d = \begin{bmatrix} 0 & 1 & 0 \\ 0 & 0 & 1 \\ 0 & 0 & 0 \end{bmatrix} \quad B_J = \begin{bmatrix} 0 \\ 0 \\ 1 \end{bmatrix} \quad \text{and } \underline{z} = \begin{bmatrix} y \\ v \\ a \end{bmatrix} \quad (10)$$

Here j_c is equal to the reconstructed jerk (acceleration derivation) that is the difference between the desired value and a second feedback. This loop is useful and necessary to stabilise the system by fixing the dynamic of error cancellation.

$$j_c = j_d - K_{y2} \times (y_d - y) - K_{v2} \times (v_d - v) - K_{a2} \times (a_d - a) \quad (11)$$

The friction has been neglected in the modelling part. The problem of sticking at the start time is solved by using an additional parameter noted u^{boost} which leads to saturate the control during few sample times as shows figure 2.

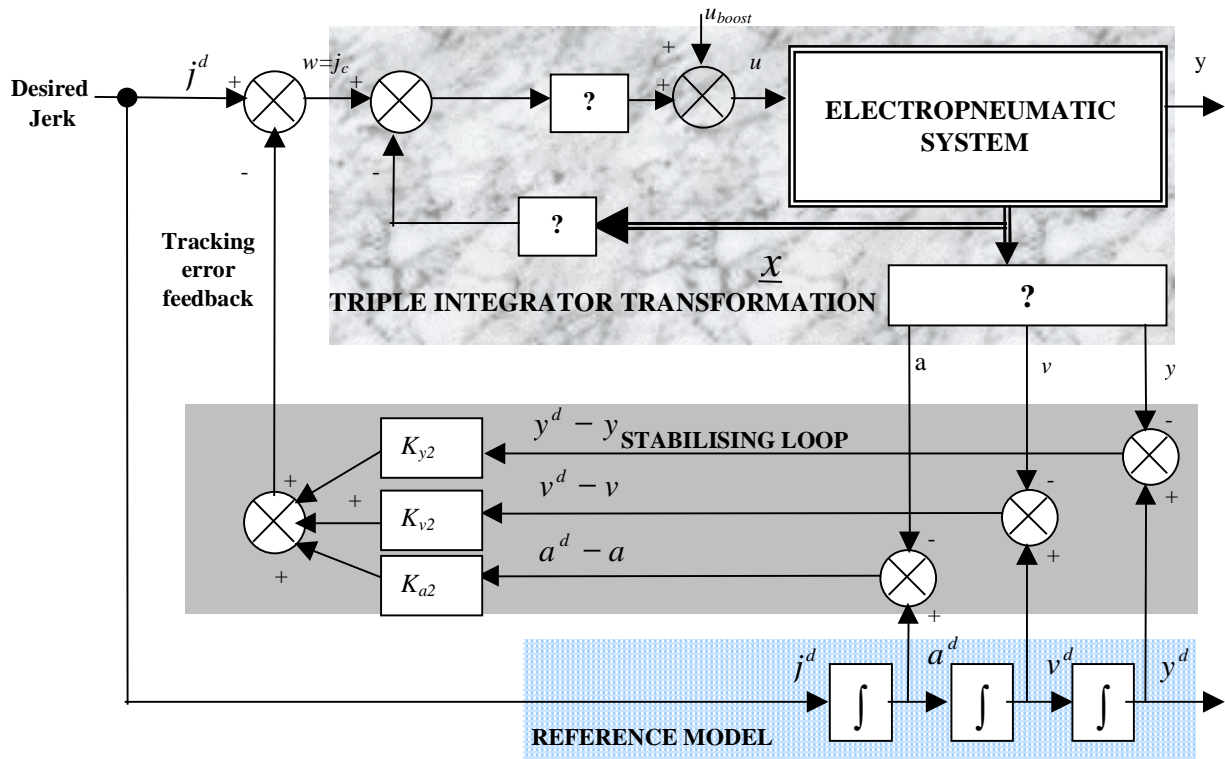

Figure 2: Principle of tracking control

4 LINEAR TRACKING CONTROL

Using the principle described above, the linear control tracking is synthesized with the tangent linearized model described by expression (7). The first loop gains are calculated from this reduced linearized third order model, calculated in the cylinder central position. This is the worst position for dynamic behaviour. This loop consists of a state feedback with fixed gains in position, velocity and the acceleration.

$$u = -K_1 \underline{z} + u_c \quad \text{with} \quad u_c = \frac{1}{b} j_c \quad K_1 = \begin{bmatrix} K_{y1} \\ K_{v1} \\ K_{a1} \end{bmatrix} \quad \text{so} \quad \begin{cases} K_{p1} = 0 \\ K_{v1} = -\frac{W_{ol}^2}{b} \\ K_{a1} = -\frac{2Z_{ol}W_{ol}}{b} \end{cases} \quad (12)$$

5 NONLINEAR TRACKING CONTROL

The electropneumatic model (7) is in the nonlinear affine form $\dot{\underline{x}} = f(\underline{x}) + g(\underline{x})U$, with:

$$\underline{x} = \begin{bmatrix} p_P \\ p_N \\ v \\ y \end{bmatrix}, \quad U = \Gamma(u), \quad f(x) = \begin{pmatrix} \frac{krT_s}{V_P(y)} \left[j(p_P) - \frac{S_P}{rT_s} p_P v \right] \\ \frac{krT_s}{V_N(y)} \left[j(p_N) + \frac{S_N}{rT_s} p_N v \right] \\ \frac{1}{M} [S_P p_P - S_N p_N - f_v v - F_{ext}] \\ v \end{pmatrix} \quad g(x) = \begin{pmatrix} \frac{krT_s}{V_P(y)} \gamma(p_P, \text{sgn}(U)) \\ -\frac{krT_s}{V_N(y)} \gamma(p_N, \text{sgn}(-U)) \\ 0 \\ 0 \end{pmatrix} \quad (13)$$

A convenient way to linearized it for every position of the cylinder piston, is to use the nonlinear linearizing control law [Isidori 1989], which theoretically transforms the closed loop system into two parts. The first part consists of a cascade of r integrators and the second part is an unobservable subsystem of dimension $(n-r)$ (ρ is the relative order of the output, n is the system order). In equation (15) :

$$\left\{ \begin{array}{l} w \text{ is the linearized system input} \\ L_f h \text{ is the Lie derivative of } h \text{ along } f \text{ which is given by } L_f h(x) = \sum_{i=1}^n \frac{\partial h}{\partial x_i} f_i(x) \\ L_g h \text{ is the Lie derivative of } h \text{ along } g \\ r \text{ is the characteristic number associated to the output : } r = \min \{k \in N / L_g L_f^{k-1} \neq 0\} \end{array} \right.$$

A simple calculation shows that the characteristic number is equal to three. A local diffeomorphism around an equilibrium state is obtained. In the new co-ordinates, the closed-loop system becomes:

$$\begin{cases} \frac{dy}{dt} = v \\ \frac{dv}{dt} = a \\ \frac{da}{dt} = w = j_c \\ \frac{dp_p}{dt} = \frac{krT_s}{V_p(y)} \left[j(p_p) - \frac{S_p}{rT_s} p_p v + \gamma(p_p, \text{sgn}(U))U \right] \end{cases} \quad (14)$$

In the single input output case, the linearizing nonlinear control is given by:

$$U = \frac{1}{L_g L_f^2 h} (-L_f^3 h + w) \quad \text{with} \quad \begin{cases} L_g L_f^2 h = \frac{S_p}{M} \frac{krT_s}{V_p(y)} \gamma(p_p, \text{sgn}(U)) + \frac{S_N}{M} \frac{krT_s}{V_N(y)} \gamma(p_N, \text{sgn}(-U)) \\ L_f^3 h = \frac{S_p}{M} \frac{krT_s}{V_p(y)} \left[j(p_p) - \frac{S_p}{rT_s} p_p v \right] - \frac{S_N}{M} \frac{krT_s}{V_N(y)} \left[j(p_N) + \frac{S_N}{rT_s} p_N v \right] \end{cases} \quad (15)$$

It is important to note that the control U is not implicit. Indeed, $L_g L_f^2 h$ being always strictly positive, U has the same sign as $(-L_f^3 h + w)$, and according to 15, w is by definition independent of U and $L_f^3 h$.

It can be noticed that on the contrary to the linear first feedback, this nonlinear feedback requires additionally the measurement of the two chamber pressures.

Concerning the stability of the residual dynamic, some results are given by [Richard 1999] and [Brun 1999a].

6 CHOICE OF ADMISSIBLE TRAJECTORIES

The relative order of the position output of the electropneumatic system is three. This means that there are "three integrators" between the control input of the system and the output, which is the cylinder piston position. This means that the electropneumatic system can only track position trajectories at least three times differentiable. To respect industrial necessity, the trajectory has been chosen with physical criteria, in terms of maximum velocity, maximum acceleration and duration with constant velocity or acceleration. The trajectory corresponds to a constant piecewise time function for the jerk (acceleration time derivative) and is generated by a triple integrator reference model.

All results presented in the following section have been obtained for two different trajectories with the same movement amplitude (90% of total stroke) and the same time displacement: 2.04 seconds. For the first trajectory the velocity is constant for about 90% of the displacement time, see figure 3a, and for the second trajectory, there is a constant acceleration phase (for about 45% of movement), and an equal constant deceleration phase: see figure 3b.

These two kinds of trajectories are very often used in industrial processes. Many robots are controlled with a constant velocity phase. This can be used in painting systems, for example. The limitation of

acceleration and jerk is useful for positioning systems which carry delicate loads or dangerous liquids in containers (as in the chemical industry), it can be done with the second trajectory (fig 3b).

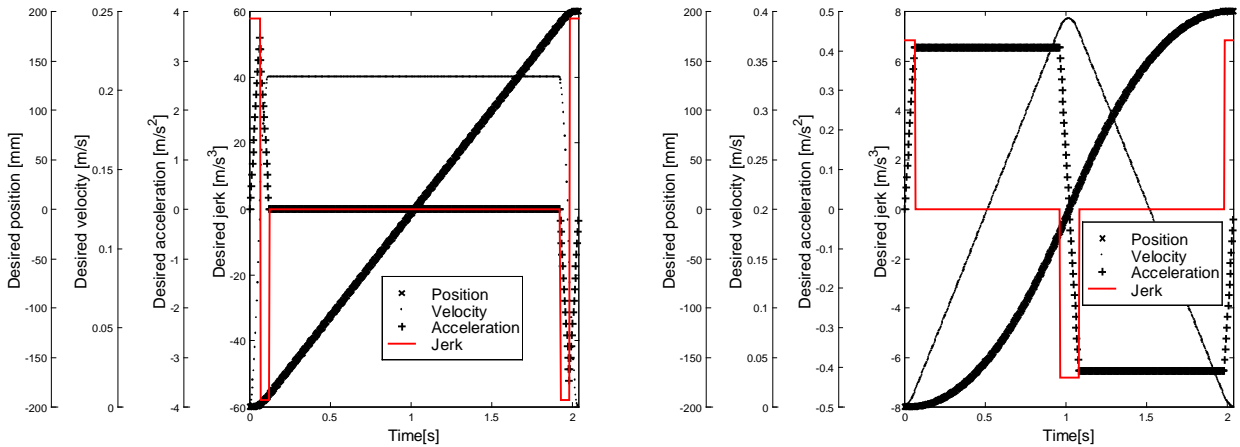

a Trajectory 1 with constant velocity.

b Trajectory 2 with constant acceleration.

Figure 3: Choice of desired trajectories

7 EXPERIMENTAL RESULTS

All results are obtained for one hundred cycles and presented in terms of repeatability. The mean value, standard deviation (sigma), maximum and minimum values of position and velocity errors are calculated all along the trajectory.

An example of the obtained results is shown in figures 4 and 5 for the trajectory 1 in the case of rod out movement. The different curves correspond to a statistical analysis of linear and nonlinear tracking. These results are more detailed in [Brun 1999a].

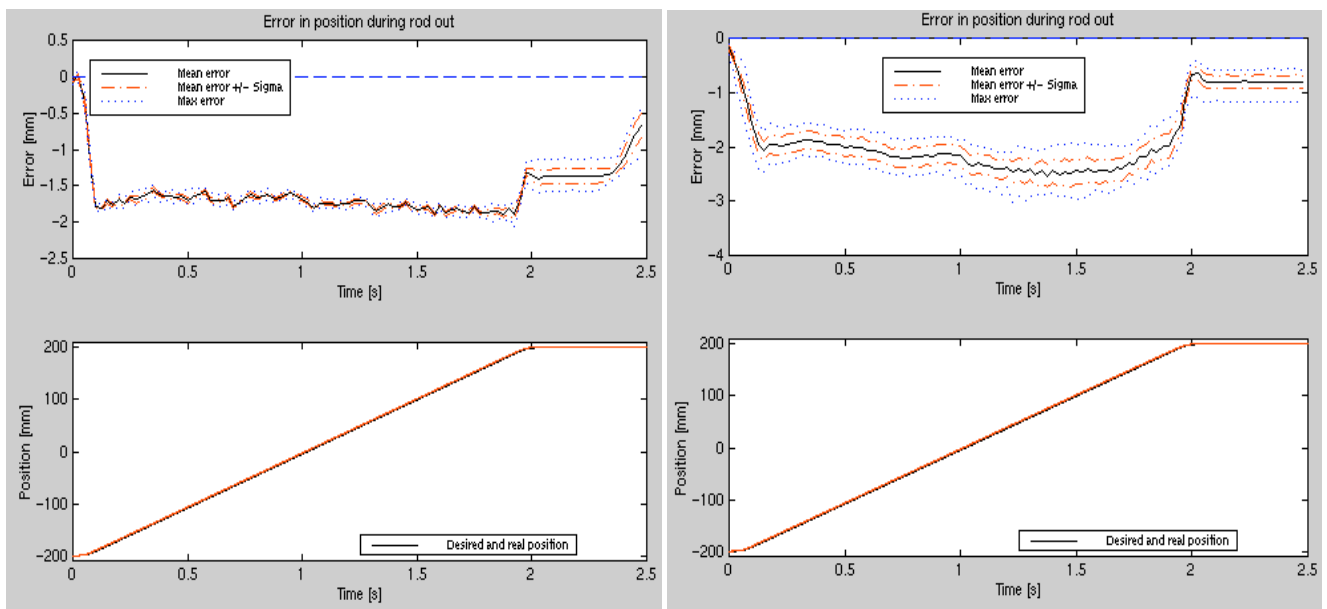

a Linear control results

b Nonlinear control results

Figure 4: Error in position

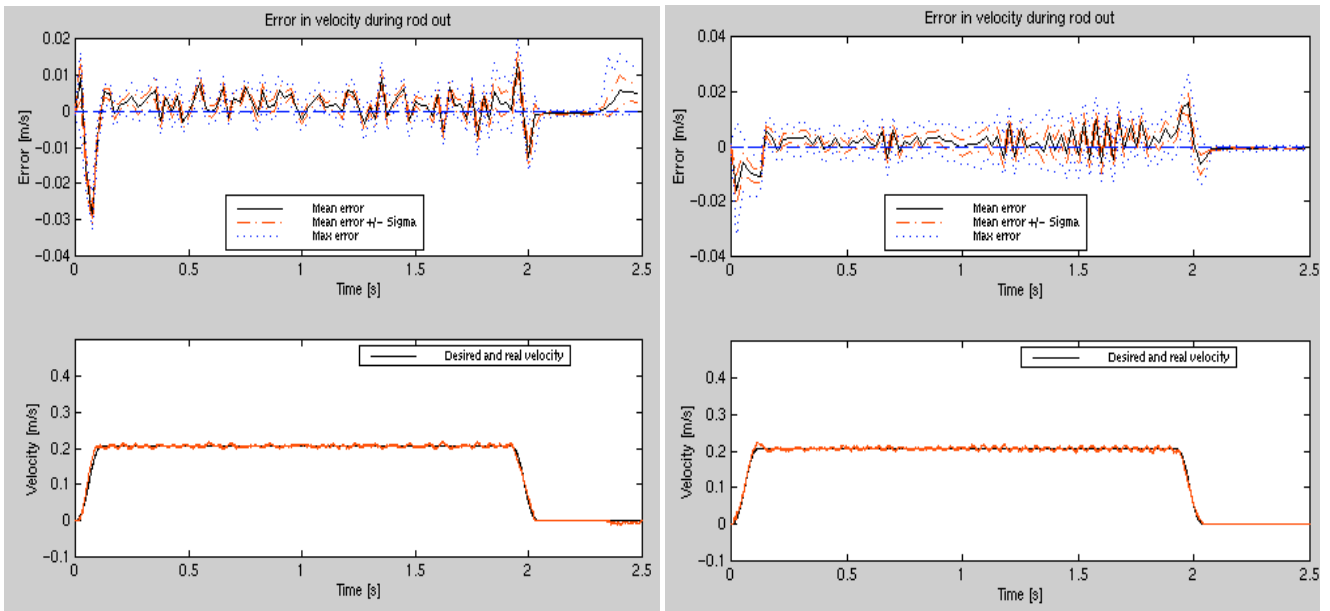

Figure 5: Error in velocity

Firstly it is important to note that both control laws lead to good results with the two trajectories all along the cylinder stroke. The results are similar in steady state with the two control laws: the steady state error is about 0.20 millimetres.

A detailed study of all curves shows the improvement obtained with nonlinear control law during dynamic phases with constant velocity and constant acceleration or deceleration stages. An improvement of at least 25% can be seen in the maximum position and velocity error recorded with the nonlinear control law. During the constant velocity stage (trajectory 1), the tracking position error is less than 4 millimetres with the linear control law and lower than 3 millimetres with the nonlinear control law. These two errors are respectively equal to 8 and 6 millimetres during constant acceleration or deceleration stages.

The improvement due to nonlinear control law in terms of velocity tracking is even more appreciable. The maximum tracking velocity error for the first trajectory is about 0.07 m/s with linear control law and 0.05 m/s with nonlinear and respectively 0.04 m/s and 0.02 m/s with the second trajectory.

The improvement obtained with the use of nonlinear law is not very surprising since for the synthesis, the non linearity of the flow stage mass flow rate are taken into account by the approximation (2). On the contrary, the use of the tangent linearized model transforms the system in a triple integrator (as the reference model) only for one position.

An other improvement due to nonlinear control law comes from the reduction of sticking and restarting phenomenon [Brun 1999b], which is a very restrictive fact for the development of electropneumatic actuator.

8 CONCLUSIONS

The table 1 resumes and compare the main results obtained with two control laws in tracking. This study was lead in order to help the users of electropneumatic actuators to choose an appropriate strategy of control for fixed specifications.

<i>CONTROL:</i>	LINEAR	NONLINEAR
Static error	+	+
Error in position tracking	+	++
Error in velocity tracking	++	++
Standard deviation	+	++
Stick-slip occurrence	--	+
Number of sensors	1	3
Complexity to synthesis	+	--
Complexity to regulate	+	+

Table 1: Results synthesis.

For industrial applications, the complexity of nonlinear control will not be a problem in terms of numerical implementation. Although, the nonlinear linearizing control law needs two additional pressure sensors. This is not nowadays a financial difficulty. It is important to note that the linear control is far easier and straightforward to synthesise, and it can be the right solution in some applications where less precision is required.

NOTATION

$C_{P(P\ or\ N)J}^e = - \frac{\partial q_J}{\partial p_x} \Big _e$	partial derivative of the mass flow rate q_J according to $p_{(P\ or\ N)}$ around equilibrium state (kg/s/Pa)
f_v	viscous friction coefficient (N/m/s)
F	force (N)
$G_{uJ}^e = \frac{\partial q_J}{\partial u} \Big _e$	partial derivative of the mass flow rate q_J according to u around equilibrium state (kg/s/V)
k	polytropic constant
K_y, K_v, K_a	position gain (V/m), velocity gain (V/m/s) and acceleration gain (V/m/s ²)
M	total load mass (kg)
$P_{(P\ or\ N)}$	pressure in the cylinder chamber P or N (Pa)
$q_{m(P\ or\ N)}$	mass flow rate provided from the servo-distributor to cylinder chamber X (kg/s)
r	perfect gas constant related to unit mass (J/kg/K)
S_X	area of the piston cylinder on the chamber P or N (m ²)
T	temperature (K)
u	servo-distributor input voltage (V)
$V_{D(P\ or\ N)}$	volume of the chamber P or N (m ³)
y, v, a, j	position (m), velocity (m/s), acceleration (m/s ²), jerk (m/s ³)
τ	time constant (s)

$j(\cdot)$	leakage polynomial function (kg/s)
$y(\cdot)$	polynomial function (kg/s/m ²)
$\Gamma(\cdot)$	control polynomial function (m ²)

Subscript

cl	closed loop
d	desired
E	exhaust
ext	external
f	dry friction
N	chamber N
ol	open loop
P	chamber P
S	supply
v	viscous friction
0	initial value

Superscript

e	equilibrium
---	-------------

REFERENCES

Belgharbi, M., Thomasset, D., Scavarda, S., Sesmat, S., (1999) *Analytical model of the flow stage of a pneumatic servo-distributor for simulation and nonlinear control.*, in the Sixth Scandinavian International Conference on Fluid Power, SICFP'99, Tampere, Finland, p847-860.

Brun, X., Belgharbi, M., Sesmat, S., Thomasset, D., Scavarda, S. (1999a) *Control of an electropneumatic actuator, comparison between some linear and nonlinear control laws*, Journal of Systems and Control Engineering, Vol. 213, N°15, p 387-406.

Brun, X., Sesmat, S., Scavarda, S., Thomasset, D., (1999b) *Simulation and experimental study of the partial equilibrium of an electropneumatic positioning system, cause of the sticking and restarting phenomenon* in 4th Japan Hydraulics Pneumatics Society, Tokyo, p 125-130.

Edge, K.A. (1997) The control of fluid power systems - responding to the challenge. *Journal of Systems and Control Engineering*, Vol 211, N°12, p. 91-110.

Isidori, A. (1989) *Nonlinear control systems*. New York : Springer Verlag, 2nd edition, 479 p.

Kellal, A., Scavarda, S., Fontaine, J.G. (1986) *Electropneumatic servodrive for a robot*. Proceedings of the 16th ISIR - International Symposium on Industrial Robots, Brussels, Belgium, p. 117-128

Richard, E., Scavarda, S., (1989) *Nonlinear control of pneumatic servodrive*. Proc. Second Bath Int. Fluid Power Workshop Bath (U.K.), p. 59-75.

Shearer, J.L., (1956) *Study of pneumatic processes in the continuous control of motion with compressed air*. Parts I and II. Trans. Am. Soc. Mech. Eng., Vol. 78, p. 233-249.