



HAL
open science

Hybrid Membrane Based Systems for Carbon dioxide Capture on Natural Gas Turbines and Coal Power Plants

Bouchra Belaissaoui, Yann Le Moullec, Gilles Cabot, Eric Favre, David Wilson

► **To cite this version:**

Bouchra Belaissaoui, Yann Le Moullec, Gilles Cabot, Eric Favre, David Wilson. Hybrid Membrane Based Systems for Carbon dioxide Capture on Natural Gas Turbines and Coal Power Plants. The 7th Trondheim CCS Conference (TCCS-7), Jun 2013, Trondheim, Norway. hal-02015515

HAL Id: hal-02015515

<https://hal.science/hal-02015515v1>

Submitted on 19 Feb 2019

HAL is a multi-disciplinary open access archive for the deposit and dissemination of scientific research documents, whether they are published or not. The documents may come from teaching and research institutions in France or abroad, or from public or private research centers.

L'archive ouverte pluridisciplinaire **HAL**, est destinée au dépôt et à la diffusion de documents scientifiques de niveau recherche, publiés ou non, émanant des établissements d'enseignement et de recherche français ou étrangers, des laboratoires publics ou privés.

Hybrid Membrane Based Systems for Carbon dioxide Capture on Natural Gas Turbines and Coal Power Plants

Bouchra Belaïssaoui^{a,*}, Yann Le Moullec^b, Gilles Cabot^c, David Willson^d, Eric Favre^a

^aLRGP-CNRS Université de Lorraine, 1 rue Grandville 54001 Nancy, France

^bEDF R&D, Département Mécanique des Fluides, Energies et Environnement, 6 quai Watier- BP 49 78401 Chatou, France

^cUMR 6614 CORIA, INSA de Rouen, Avenue de l'Université, BP 08, 76801 Saint-Etienne du Rouvray, France

^dStanbridge Capital, 37 East 18th Street, New York, NY 10003, USA

Corresponding author's e-mail address:

Email: bouchra.belaïssaoui@univ-lorraine.fr

Preferred type of presentation: oral

This abstract can be published in the Book of Abstracts on the Web.

Keywords :Post-combustion; carbon dioxide capture; membrane ; cryogeny; oxygen enriched air ; energy requirement; natural gas turbine; coal power plant

ABSTRACT

The design of an energy efficient CO₂ capture unit is of great importance for the deployment of Carbon Capture and Storage (CCS) technologies at industrial scale and more specifically for post-combustion framework. In that case, both CO₂ capture ratio and CO₂ purity should be high enough (typically above 90%) [1]. Today, the best currently available technology is absorption in a chemical solvent (such as monoethanolamine, MEA) and is considered as a reference for post combustion capture. The corresponding energy requirement is of approximately 4GJ_{th} (thermal basis)/ton of recovered CO₂ (including compression requirement). A target of 2 GJ_{th}/ton is often mentioned according to the European Union recommendations [2]. Membrane processes have shown growing interest as an alternative to this reference technology. However they remain energy intensive when both high CO₂ purity and capture ratio are imposed and when diluted CO₂ flue gas are to be treated [3]. Consequently, for diluted CO₂ flue gases containing 5 % and 15% CO₂, typical of a natural gas turbine flue gas and coal combustion respectively, a multi-stage membrane processes or hybrid systems are needed to achieve the capture targets [4,5]. However, design studies on hybrid processes based on a membrane unit for carbon capture are scarce [6]. In this work, two hybrid processes are investigated (through simulation) for CO₂ capture on natural gas turbine and coal power plant respectively: (i) A hybrid process combining flue gas recycling, combustion in oxygen enhanced air (OEA) and CO₂ capture by membranes (ii) A hybrid membrane / cryogenic separation based on a first step CO₂ pre-concentration with a membrane unit and a second step CO₂ cryogenic condensation. For each hybrid process, a parametric analysis has been performed regarding the process parameters and the membrane CO₂ /N₂ selectivity, covering current and prospective material development. Finally, the optimal operating conditions are identified and the potential improvement of the overall efficiency is discussed.

1. Natural gas turbine

As mentioned above, there is a substantial benefit derived from strategically increasing the feed gas CO₂ concentration. Based on this, a hybrid process performance for CO₂ capture on a gas turbine, based on a combination of flue gas recycling, combustion in oxygen enhanced air (OEA) and membrane separation has been evaluated. A general diagram of the process is shown in Figure 1.

Interestingly, energy requirements below 2.4 GJ/ton (including compression requirement) can be attained. Moreover, the membrane selectivity performances (tested between $\alpha = 50$ and $\alpha = 200$) play a key role on the overall energy requirement, situation that differs from the direct “end of pipe” post-combustion carbon capture, where no significant improvement on the energy requirement is observed as soon as the membrane selectivity reaches a value of $\alpha = 50$ (commercial membrane performance). Thus, the development of highly selective membranes, far above the performances of the actual membrane materials, is of major interest for the gas turbine / membrane capture process. Furthermore, it is shown that moderate inlet pressure values (12-22 bar), together with moderate oxygen purities (45-53 %) are needed for optimal hybrid carbon capture process conditions [7].

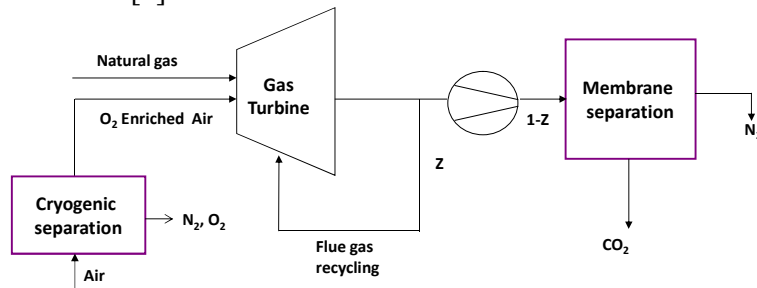

Figure 1: Diagram of the hybrid membrane gas turbine with flue gas recycling (FGR) and oxygen enriched combustion (OEA).

2. Coal power plant

As shown in earlier studies [3,5], when moderate CO₂ purity in the permeate is considered, the energy requirement decreases significantly, suggesting that membrane process could play a role of a pre-concentration process combined with a technology that benefits from a higher inlet CO₂ concentration. Otherwise, cryogenic separation is known to be energy efficient once a concentrated CO₂ flue gas is treated (above 40%). This suggests that a synergy between the two processes could occur leading to a minimal overall energy requirement. Based on these considerations, a hybrid membrane cryogenic process is evaluated. Figure 2 provides a flow sheet of the process. The simulation results of a hybrid membrane cryogenic process show reduced energy requirement compared to the reference technology. Compared to standalone cryogenic approach, the hybrid process effectively improves the energy efficiency. An energy requirement below 3 GJ/ton (thermal basis, including compression requirement to 110 bars) is obtained [8].

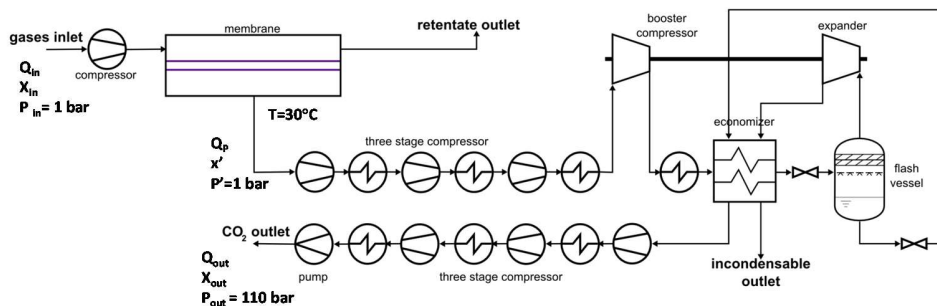

Figure 2: A diagram of the hybrid membrane cryogenic process.

From the membrane material point of view, an improved selectivity (100 in place of 50) does not offer significant benefit in term of energy requirement while the membrane surface area increases. Thus, for this hybrid process, commercially available membranes with a selectivity of 50 seem to be appropriate.

Conclusion

The promising results of both hybrid processes call for a more in depth analysis and several unexplored issues have to be considered for future works. Importantly, technico-economical analyses, including capital cost evaluation (membrane area, compressors...) should be undertaken in order to better evaluate the potential of these hybrid processes for CO₂ capture.

References

- [1] O. Davidson, B. Metz, Special Report on Carbon Dioxide Capture and Storage, International Panel on climate Change, Geneva, Switzerland (2005) <http://www.ipcc.ch>.
- [2] P. Descamps, P.A. Pilavachi, Research and development actions to reduce CO₂ emissions within the European Union. *Oil Gas Sci Technol* 59(3) (2004) 323-30.
- [3] N Bounaceur, N. Lape, D. Roizard, C. Vallières, E. Favre, Membrane processes for post-combustion carbon dioxide capture: a parametric study, *Energy*, 31 (2006) 2556-2570.
- [4] R. Agrawal, S.R. Auvil, J.S. Choe, D.W. Woodward, Membrane/cryogenic hybrid scheme for argon production from air, *Gas Separation & Purification*, 4, 2 (1990) 75-80.
- [5] B. Belaisaoui, D. Willson, E. Favre, Membrane gas separations and post-combustion carbon dioxide capture: Parametric sensitivity and process integration strategies, *Chemical Engineering Journal* 211–212 (2012) 122–132.
- [6] AS Bhowan, BC Freeman, Analysis and Status of Post-Combustion Carbon Dioxide Capture Technologies, *Source: environmental science & technology*, 45,20 (2011) 8624-863.
- [7] B. Belaisaoui, G. Cabot, M.S Cabot, D. Willson, E. Favre, An energetic analysis of CO₂ capture on a gas turbine combining flue gas recirculation and membrane separation, *Energy*, 38 (2012) 167-175.
- [8] B. Belaisaoui, Y. Le Moullec, D. Willson, E. Favre, Hybrid Membrane Cryogenic Process for Post-Combustion CO₂ Capture, *Journal of Membrane Science*, 415-416 (2012) 424-434.