



HAL
open science

On Aperiodic Reversible Turing Machines (invited talk)

Nicolas Ollinger

► **To cite this version:**

Nicolas Ollinger. On Aperiodic Reversible Turing Machines (invited talk). Reversible Computation 10th International Conference (RC 2018), Sep 2018, Leicester, United Kingdom. pp.61-64, 10.1007/978-3-319-99498-7_4. hal-01984995

HAL Id: hal-01984995

<https://hal.science/hal-01984995>

Submitted on 17 Jan 2019

HAL is a multi-disciplinary open access archive for the deposit and dissemination of scientific research documents, whether they are published or not. The documents may come from teaching and research institutions in France or abroad, or from public or private research centers.

L'archive ouverte pluridisciplinaire **HAL**, est destinée au dépôt et à la diffusion de documents scientifiques de niveau recherche, publiés ou non, émanant des établissements d'enseignement et de recherche français ou étrangers, des laboratoires publics ou privés.

On Aperiodic Reversible Turing Machines (invited talk)*

Nicolas Ollinger

Univ. Orléans, INSA Centre Val de Loire, LIFO EA 4022, FR-45067 Orléans, France
nicolas.ollinger@univ-orleans.fr

Abstract. A complete reversible Turing machine bijectively transforms configurations consisting of a state and a bi-infinite tape of symbols into another configuration by updating locally the tape around the head and translating the head on the tape. We discuss a simple machine with 4 states and 3 symbols that has no periodic orbit and how that machine can be embedded into other ones to prove undecidability results on decision problems related to dynamical properties of Turing machines.

Keywords: reversible Turing machines · cellular automata · dynamical systems · undecidability · aperiodicity

In this talk, we present a small minimal aperiodic reversible Turing machines and new reduction techniques to study the (un)decidability of dynamical properties of reversible Turing machines. This work is motivated by the study of the computational complexity of dynamical properties of cellular automata, a more classical family of dynamical systems.

Motivation

A *cellular automaton* (Q, f) is given by a finite *set of states* Q and a *local rule* $f : Q^3 \rightarrow Q$. The automaton transforms a *configuration* $c \in Q^{\mathbb{Z}}$ into a configuration $F(c)$ by applying the local rule uniformly and synchronously: for all $i \in \mathbb{Z}$, $F(c)(i) = f(c(i-1), c(i), c(i+1))$. From a dynamical point of view, we study the set of *orbits* $c, F(c), F^2(c), \dots, F^t(c), \dots$ of the configurations c of the dynamical system $(Q^{\mathbb{Z}}, F)$. Among the simplest dynamics are the case when the automaton is *nilpotent*, *i.e.* every orbit converges to a same fixpoint (formally $\exists c_0 \forall c \exists t F^t(c) = c_0$), and the case when the automaton is *periodic*, *i.e.* every orbit is a loop (formally $\forall c \exists t F^t(c) = c$).

The NILPOTENCY PROBLEM is the decision problem that, given Q and f as input, decides if the cellular automaton (Q, f) is nilpotent. This problem was proven undecidable by Kari in 1992 [7]. The proof involves computing inside deterministic aperiodic tile sets, sets of Wang tiles that tile the plane but only

* The results presented in this talk were obtained in joint work with J. Cassaigne, A. Gajardo, J. Kari and R. Torres-Avilés.

aperiodically, without any vector of periodicity. It builds on the undecidability of the Domino Problem proven by Berger [1] and the construction of small aperiodic tile sets by Robinson [9] and others.

The PERIODICITY PROBLEM is the decision problem that, given Q and f as input, decides if the cellular automaton (Q, f) is periodic. We proved the undecidability of this problem with Kari in 2008 [6]. The proof involves computing inside reversible aperiodic Turing machines, reversible Turing machines without periodic orbits. It builds on the undecidability of the Immortality Problem proven by Hooper [5] and the construction of aperiodic Turing machines by Blondel *et al.* [2].

Aperiodic Reversible Turing Machines

A *complete Turing machine* is a triple (Q, Σ, δ) where Q is a finite set of states, Σ is the finite alphabet of symbols and $\delta : Q \times \Sigma \rightarrow Q \times \Sigma \times \{-1, 0, 1\}$ is the transition function of the machine. A *configuration* of the machine is a triple (s, c, p) where $s \in Q$ is the current state, $c \in \Sigma^{\mathbb{Z}}$ is the content of the *bi-infinite tape* and $p \in \mathbb{Z}$ is the position of the head of the machine on the tape. A *transition* of the machine transforms a configuration (s, c, p) into a configuration $(s', c', p + d)$ where $\delta(s, c(p)) = (s', a, d)$ and c' is equal to c in every position except for $c'(p) = a$.

Two configurations (s, c, p) and (s', c', p') are *equal up to translation* if $s = s'$ and $c(i + p) = c'(i + p')$ for all $i \in \mathbb{Z}$.

A configuration is *periodic up to translation* if, starting from that configuration, the machine reaches a configuration equal to the first one up to translation after a finite number of transitions. The machine is *aperiodic* if it has no configuration periodic up to translation.

The machine is *injective* if every configuration has a pre-image by a transition and *surjective* if every configuration has a different image by a transition of the machine.

For complete machines, injective is equivalent to surjective and corresponds to *reversible* machines: it can be assigned a reverse. An injective Turing machine is characterized by a pair (ρ, μ) , where $\rho : Q \times \Sigma \rightarrow Q \times \Sigma$ is a permutation on $Q \times \Sigma$ and $\mu : Q \rightarrow \{-1, 0, 1\}$, such that $\delta(s, a) = (s', b, \mu(s'))$ where $\rho(s, a) = (s', b)$ for every state s and symbol a . The *reverse machine* is the machine (Q, Σ, δ^{-1}) such that $\delta^{-1}(s', b) = (s, a, -\mu(s))$. For every configuration (s, c, p) transformed by the machine into a configuration (s', c', p') , the configuration $(s', c', p' - \mu(s'))$ is transformed by the reverse machine into the configuration $(s, c, p - \mu(s))$.

The existence of aperiodic Turing machines might feel counter-intuitive. Indeed, K urka [8] first conjectured that every complete Turing machine has a periodic configuration. The first aperiodic machine was later constructed by Blondel *and al* [2].

The most important object of this talk is the 4 states 3 symbols aperiodic complete reversible Turing machine constructed in [3], we describe the machine,

its dynamics and main properties. The formal definition of the machine is given on Table 1 and depicted on Figure 1.

In a second part of the talk, we describe the *embedding technique*, a technique to combine a pair of Turing machine (one of which is usually the SMART machine) to preserve some properties of one of the machines. It turns out to be a precious tool to address the computational complexity of several decision problems concerning dynamical properties of Turing machines. We discuss different properties including: existence of an orbit periodic up to translation [3], periodicity [6], transitivity [4] (every finite context, partial tape and state, can be reached from every finite context), minimality [4] (every finite context, partial tape and state, can be reached from every configuration).

<i>state/symbol</i>	0	1	2
PING \blacktriangleright	(PING \blacktriangleleft ,1, \blacktriangleright)	(PONG \blacktriangleleft ,1, \blacktriangleleft)	(PONG \blacktriangleleft ,2, \blacktriangleleft)
PONG \blacktriangleleft	(PING \blacktriangleleft ,2, \blacktriangleleft)	(PING \blacktriangleleft ,0, \blacktriangleleft)	(PONG \blacktriangleright ,0, \blacktriangleright)
PING \blacktriangleleft	(PING \blacktriangleright ,1, \blacktriangleleft)	(PONG \blacktriangleright ,1, \blacktriangleright)	(PONG \blacktriangleright ,2, \blacktriangleright)
PONG \blacktriangleright	(PING \blacktriangleright ,2, \blacktriangleright)	(PING \blacktriangleright ,0, \blacktriangleright)	(PONG \blacktriangleleft ,0, \blacktriangleleft)

where \blacktriangleleft encodes head shift -1 and \blacktriangleright encodes head shift $+1$

Table 1. The SMART machine transition table

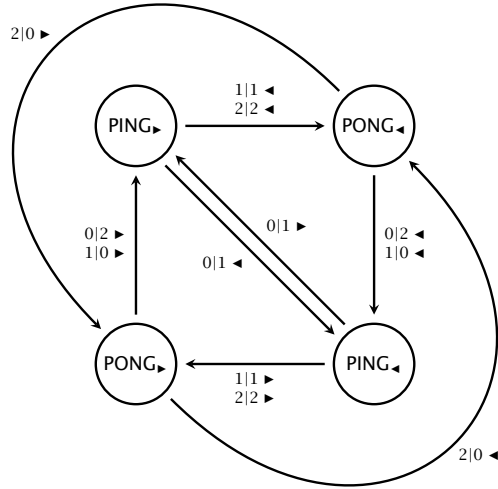

Fig. 1. The SMART Machine

References

1. Berger, R.: The undecidability of the domino problem. *Memoirs American Mathematical Society* **66** (1966)
2. Blondel, V.D., Cassaigne, J., Năchitîu, C.: On the presence of periodic configurations in Turing machines and in counter machines. *Theoret. Comput. Sci.* **289**, 573–590 (2002)
3. Cassaigne, J., Ollinger, N., Torres-Avilés, R.: A small minimal aperiodic reversible Turing machine. *J. Comput. Syst. Sci.* **84**, 288–301 (2017)
4. Gajardo, A., Ollinger, N., Torres-Avilés, R.: The transitivity problem of Turing machines. In: Italiano, G.F., Pighizzini, G., Sannella, D. (eds.) *Mathematical Foundations of Computer Science (MFCS 2015)*. LNCS, vol. 9234, pp. 231–242 (2015)
5. Hooper, P.K.: The undecidability of the Turing machine immortality problem. *J. Symbolic Logic* **31**(2), 219–234 (1966)
6. Kari, J., Ollinger, N.: Periodicity and immortality in reversible computing. In: Ochmanski, E., Tyszkiewicz, J. (eds.) *Mathematical Foundations of Computer Science (MFCS 2008)*. LNCS, vol. 5162, pp. 419–430 (2008)
7. Kari, J.: The nilpotency problem of one-dimensional cellular automata. *SIAM J. Comput.* **21**(3), 571–586 (1992)
8. Kůrka, P.: On topological dynamics of Turing machines. *Theoret. Comput. Sci.* **174**(1-2), 203–216 (1997)
9. Robinson, R.M.: Undecidability and nonperiodicity for tilings of the plane. *Invent. Math.* **12**, 177–209 (1971)