



HAL
open science

Analysis of vibrations on an aerial cable car system with moving mass

Cesar Augusto Lampe Linhares Da Fonseca, Guilherme Sampaio Rodrigues de Paula, Marcelo da Cruz Pereira, Americo Cunha Jr

► **To cite this version:**

Cesar Augusto Lampe Linhares Da Fonseca, Guilherme Sampaio Rodrigues de Paula, Marcelo da Cruz Pereira, Americo Cunha Jr. Analysis of vibrations on an aerial cable car system with moving mass. XVIII International Symposium on Dynamic Problems of Mechanics (Diname 2019), Mar 2019, Armação dos Búzios, Brazil. hal-01974723

HAL Id: hal-01974723

<https://hal.science/hal-01974723>

Submitted on 9 Jan 2019

HAL is a multi-disciplinary open access archive for the deposit and dissemination of scientific research documents, whether they are published or not. The documents may come from teaching and research institutions in France or abroad, or from public or private research centers.

L'archive ouverte pluridisciplinaire **HAL**, est destinée au dépôt et à la diffusion de documents scientifiques de niveau recherche, publiés ou non, émanant des établissements d'enseignement et de recherche français ou étrangers, des laboratoires publics ou privés.

Analysis of vibrations on an aerial cable car system with moving mass

Cesar Augusto Fonseca¹, Guilherme Rodrigues², Marcelo Pereira³, and Americo Cunha Jr³

¹ Centro de Instrução Almirante Wanderkolk, Ilha das Enxadas, s/n, Baía de Guanabara, Rio de Janeiro - RJ, Brasil

² RIO Analytics, Av. Almirante Barroso, 97, Centro, Rio de Janeiro - RJ, Brasil

³ Universidade do Estado do Rio de Janeiro - UERJ, Rua São Francisco Xavier, 524, Maracanã, Rio de Janeiro - RJ, Brasil

Keywords: *nonlinear dynamics, vibrations, coupled systems, time-varying string*

The transport of people and goods over aerial cableways has been in use over the last hundred years for many different applications but published works are still only a few years old. Either by transporting uphill, between a long valley or canyon. Since it is a complex mechanical system with many bodies and subject to environment perturbation, nonlinearity features may appear such as excitation of sub and super harmonics of the cable and cause vibration to the traction mechanism, which can damage the machinery and endanger the operation.

For this work, we analyze the effect of those vibrations according to the speed of operation. The coupling of two ropes and a mass-spring system creates a complex dynamic that cause a nonlinear movement, and can even show some chaotic behavior. For such we had to study many articles that not only show horizontal cable cars, but also vertical systems such as elevators.

The study of cable car systems is an interesting subject in modern literature, with many different aspects of the system approached. Brownjohn (1998) analyses the vertical plane motion of the cable car that connects Singapore main island and the island of Sentosa. Mathematical simulations are presented for the normal operation of the system, free vibration and when the system is halted. Measurements with accelerometers were performed in the real system to obtain vibrations for each condition of operation. A finite element model of the system is then proposed and the results analyzed.

Terumichi et. al. (1997) studies the nonstationary lateral vibration of a string with time-varying length and a rail guided mass-spring system attached at the lower end, a system representative of an elevator. The string is sinusoidal excited by a horizontal displacement at its upper end. The influence of the axial velocity of the string on the vibrations are analyzed and a simplified experimental setup is presented. Experimental and simulation results are then compared showing good results.

Bao et. al. (2015) also analyzes lateral vibrations in a string in a vertical motion system analog to an elevator, but in this case, the source of excitation is the lateral motion of the mass coming from an imperfect rail guide. The Hamilton principle is used to obtain the equations of motion of the string, and experimental tests are performed and its results compared to the numerical simulations.

Kaczmarczyk and Iwankiewicz (2006) propose a stochastic approach to the source of excitation of an elevator model. The stochastic parameter is the guide rail imperfections that excite the car laterally. These imperfections are written as a zero-mean stationary Gaussian process.

The complete mechanical system is exemplified in Figure 1, where the overhung cable is shown as a cable under a constant tension T supported on both ends with density ρ , circular cross section A , and constant length L . Its model is simplified as a spring k that connects to the concentrated mass M representing the car. This car is pulled by the traction cable with density ρ' , cross section A' , and tension T' . However, this length of the traction cable varies in time with constant velocity v .

In order to find the equivalent stiffness of the rail cable a simple case study is presented. If one only considers the rail cable and the car passing through the extent of the rail cable is simplified as a concentrated load travelling with constant velocity. The solution of this problem is analytically solved and demonstrated in Hagendorn (2007). The deflection of the cable is

$$w(x,t) = -\frac{2FLv}{\rho A c \pi^2 (c^2 - v^2)} \sum_j \frac{(-1)^j}{j^2} \left[\left(\cos \frac{j\pi c}{v} - (-1)^j \right) \sin \omega_j t - \sin \frac{j\pi c}{v} \cos \omega_j t \right] \sin \frac{j\pi x}{l}. \quad (1)$$

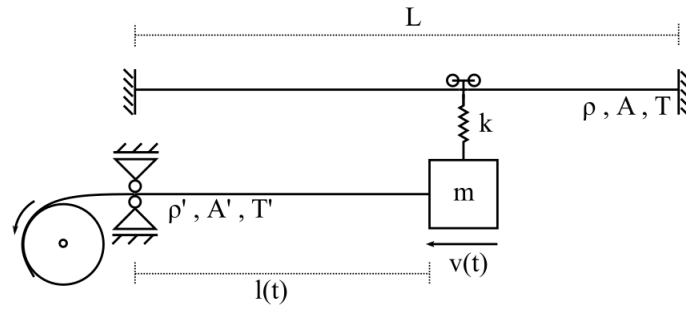

Figure 1 – The complete mechanical system

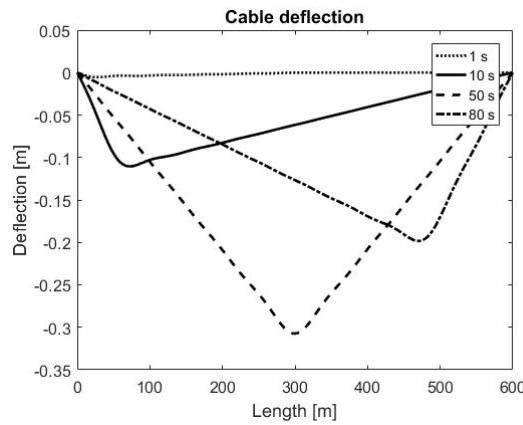

Figure 2 – Deflection of the cable with a moving load

In Figure 2 it is shown the deflection of the cable at different instants while the load moves with velocity v . The parameters used to generate these results are shown in Table 1. The deflection of the rope reaches its maximum value when the load is close to the half of the length. Therefore, the value of the equivalent stiffness of the rail cable is approximately obtained as

$$k = \frac{F}{w\left(500, \frac{L}{2}\right)} = 16.27 \frac{\text{KN}}{\text{m}}. \quad (2)$$

Then the analysis of the mechanical system of a mass being pulled by a cable can be performed. We begin by stating the kinetic and the potential energy of the rope and the mass. The total kinetic energy is

$$E_k = \frac{1}{2} \int_0^{l(t)} \rho' A' \left[\dot{y}^2 + (\dot{y} + v y')^2 \right] dx + \frac{1}{2} M \left[\dot{y}^2 + (\dot{y} + v y')^2 \right]_{l(t)}, \quad (3)$$

and the total potential energy is

$$E_p = \frac{1}{2} \int_0^{l(t)} T' (y')^2 dx + \frac{1}{2} K y^2 \Big|_{l(t)} + M g y|_{l(t)}. \quad (4)$$

Table 1 – Parameters used to model the rail cable

Parameter		[]
Linear density	ρA	39.21 kg/m
Length	L	600 m
Load	F	25 KN
Velocity	v	6 m/s
Mean Tension	T	23.87 MPa

Using the Hamilton principle with the adequate definition of the boundaries conditions and considering the variation of the length, the equations of motions of the cable and for the mass can be obtained, respectively, as

$$\rho \left(\ddot{y} + 2v\dot{y} + v^2 y'' \right) - T y'' = 0, \quad 0 \leq x < l(t), \quad (5)$$

$$M \left(\ddot{y} + 2v\dot{y} + v^2 y'' \right) \Big|_{x=l(t)} + T y' \Big|_{x=l(t)} + M g + K y \Big|_{x=l(t)} = 0, \quad (6)$$

where the \dot{y} is the time-derivative and y' is the spatial derivative. Now, it is introduced a slow time variation $\tau = \varepsilon t$, in which $\varepsilon = v/\omega_0 L_0$ and where ω_0 is the natural frequency of the cable without mass and spring and L_0 is the maximum extent of the cable. Knowing that $l(t) = L_0 + vt$, so

$$\dot{t} = v = \frac{\partial \tau}{\partial t} \frac{\partial l}{\partial \tau} = \varepsilon l'. \quad (7)$$

Therefore, we will seek solutions of the following form

$$y(x, t) = \sum_{n=1}^N \Psi_n(x, \tau) q_n(t), \quad (8)$$

where $\Psi(x, \tau) = \sin(\beta_n(\tau)x)$. The term $\beta_n(\tau)$ is a slow variation in time of the natural frequency of the cable.

Since the dynamical equations involved in the present problem are highly nonlinear, the exact solution is sought through approximate methods such as perturbation methods or by numerical methods. A Finite Element Method (FEM) is employed to solve the equations in time. Different parameters and speeds are carried out in the simulation code in order to find a mechanical configuration, which will show an excitation of a natural frequency during the simulated time.

In the present work the main contribution is the construction of a dynamical model of a car being pulled by a traction cable and simultaneously suspended by another cable working as rails. The equations that govern the elements and the adequate hypotheses are derived. This model can be further improved by considering the stiffness of the rail cable as equally varying in time and even as a continuum body with a fixed length. The results of the FEM simulations will be given in time as well as in the frequency domain, where the variation of the vibration modes and natural frequencies will be evident.

ACKNOWLEDGMENTS

The authors A. Cunha Jr and M. Pereira acknowledge the support given to this research by the funding agencies Carlos Chagas Filho Research Foundation of Rio de Janeiro State (FAPERJ) under grants E-26/010.002.178/2015, E-26/010.000.805/2018 and E-26/260.043/2018; and Coordenação de Aperfeiçoamento de Pessoal de Nível Superior - Brasil (CAPES) - Finance Code 001.

REFERENCES

- Bao, J., Zhang, P. and Zhu, C., 2015, "Dynamic Analysis of Flexible Hoisting Rope with Time-Varying Length, International Applied Mechanics, Vol. 51, No. 6, pp. 710-720.
- Brownjohn, J.M.W., 1998, "Dynamics of an Aerial Cableway System", Engineering Structures, Vol. 20, No. 9, pp. 826-836.
- Colón, D., Cunha Jr, A., Kaczmarczyk, S. and Balthazar, J.M., 2017, "On Dynamic Analysis and Control of an Elevator System Using Polynomial Chaos and Karhunen-Loève Approaches", Procedia Engineering, Vol. 199, pp. 1629-1634.
- Glushko, M.F. and Chizh, A.A., 1969, "Differential Equations of Motion for a Mine Lift Cable", International Applied Mechanics, Vol. 5, No. 12, pp. 17-23.
- Gómez, B.J., Repetto, C.E., Stia, C.R. and Weltri, R., 2007, "Oscillations of a String With concentrated Masses", European Journal of Physics, Vol. 28, pp. 961-975.
- Hagendorn, P., 1988, "Nonlinear Oscillations", Oxford Sci. Publ., Oxford.
- Kaczmarczyk, S., 1997, The Passage Through Resonance in a Catenary-Vertical Cable Hoisting System With Slowly Varying Length", Journal of Sound and Vibration, Vol. 208, No. 2, pp. 243-269.
- Kaczmarczyk, S., Iwankiewicz, R., 2006, "Dynamic response of an elevator car due to stochastic rail excitation", Proceedings of the Estonian Academy of Sciences, Vol. 55, No. 1, pp. 58-67.
- Terumichi, Y., Ohtsuka, M., Yoshizawa, M., Fukawa, Y. and Tsujioka, Y., 1997, "Nonstationary Vibrations of a String with Time-Varying Length and a Mass-Spring System Attached at the Lower End", Nonlinear Dynamics, Vol. 12, pp 39-55.

RESPONSIBILITY NOTICE

The authors are the only responsible for the printed material included in this paper.