



**HAL**  
open science

## **COST Action CA15104 Experimental Facilities Report**

Slawomir J Ambroziak, K Bregar, K Cwalina, M Deruyck, Céline Fortuna, G  
Gardašević, U Gregorc, A Hrovat, T. Javornik, F. Kaltenberger, et al.

► **To cite this version:**

Slawomir J Ambroziak, K Bregar, K Cwalina, M Deruyck, Céline Fortuna, et al.. COST Action CA15104 Experimental Facilities Report. [Research Report] COST IRACON. 2018. hal-01973646

**HAL Id: hal-01973646**

**<https://hal.science/hal-01973646>**

Submitted on 5 Jun 2019

**HAL** is a multi-disciplinary open access archive for the deposit and dissemination of scientific research documents, whether they are published or not. The documents may come from teaching and research institutions in France or abroad, or from public or private research centers.

L'archive ouverte pluridisciplinaire **HAL**, est destinée au dépôt et à la diffusion de documents scientifiques de niveau recherche, publiés ou non, émanant des établissements d'enseignement et de recherche français ou étrangers, des laboratoires publics ou privés.



# IRACON

## **COST Action CA15104 Experimental Facilities Report**

COST Action CA15104 (IRACON) aims to achieve scientific networking and cooperation in novel design and analysis methods for 5G, and beyond-5G, radio communication networks.

The scientific activities of the action are organized according to two types of Working Groups: disciplinary and experimental Working Groups. In total, IRACON consists of 6 working groups: Radio Channels (DWG1), PHY layer (DWG2), NET Layer (DWG3), OTA Testing (EWG-OTA), Internet-of-Things (EWG-IoT), Localization and Tracing (EWG-LT) and Radio Access (EWG-RA). A sub-working group of EWG-IoT was also recently created: IoT for Health.

This report details the set of experimental facilities made available by COST partners and used for the research in the framework of the EWG-IoT, EWG-LT and EWG-RA.

**Authors:** S.J. Ambroziak, K. Bregar, K. Cwalina, M. Deruyck, C. Fortuna, G. Gardašević, U. Gregorc, A. Hrovat, T. Javornik, F. Kaltenberger, M. Mohorčič, I. Ozimek, P. Rajchowski, M.T. Sandikkaya, M. Smolnikar, T. Šolc, Erik Ström, G. Villemaud, M. Vučnik, C. Buratti

**Editors:** Chiara Buratti, Sławomir J. Ambroziak

**Date:** 22 December 2017

## Contents

List of acronyms .....	3
1. Introduction .....	5
2. EWG-OTA: Over-The-Air Testing .....	16
3. EWG-IoT: Internet-of-Things .....	17
4. EWG-LT: Localisation and Tracking .....	19
5. EWG-RA: Radio Access .....	22
6. Conclusions .....	24
Annex: List of Temporary Documents .....	29

## List of acronyms

This page is intentionally left blank.

## 1. Introduction

IRACON, aims to achieve scientific breakthroughs, by introducing novel design and analysis methods for 5G, and beyond-5G, radio communication networks. IRACON aims at proposing solutions for inclusive and multidimensional communication systems with a wide variety of devices, practical constraints and real-world scenarios, addressing systems ranging from very simple transceivers and sensors, to smartphones and highly flexible cognitive radios. One of the challenges of the project is to perform experimental research on Over-the-Air (OTA) testing, IoT, localisation, tracking and radio access. These topics are addressed within four Experimental WGs (EWGs), focused on specific topics through a transversal approach.

In this framework, different experimental facilities are made available by institutions to IRACON participants in order to test new algorithms, techniques and protocols in real-world contexts, enabling a coordinated effort among experts of separated disciplines, as complex test beds need a variety of suitably joint and coordinated competences. These experimental facilities are described in this Deliverable, together with their availability (remote or on site testing) to IRACON partners.

## 2. EWG-OTA: Over-The-Air Testing

The goal of this EWG is to investigate and validate new OTA testing methods, channel models (in coordination with DWG1) for implementation in advanced OTA testing set-ups for inclusive networks (large objects, small ad-hoc networks, adaptive networks, etc.).

The experimental facilities made available by partners are described below.

### 2.1 RADIOCOM@GUT-RWPL

The radio wave propagation laboratory (RWPL) of the Department of Radio Communication Systems and Networks (RADIOCOM) at Gdańsk University of Technology (GUT) is interested in the following research topics:

- mobile and fixed field-strength measurements,
- mobile and fixed spectrum monitoring,
- propagation models for outdoor, indoor and special environments,
- radio wave propagation for aerospace and maritime systems,
- impulse response of radio channels up to 26 GHz,
- multipath propagation and radio wave polarization,
- radio wave propagation for Body Area Networks,
- radio wave propagation for wireless systems for threats monitoring and public security.

The main available measurement equipment has been listed in the table below.

**Tab. 2.1.1. List of the main available equipment at RADIOCOM@GUT-RWPL**

Category	Equipment	Pcs	Frequency band
Spectrum analyser	Agilent N9030A	1	3 Hz to 26.5 GHz
	Anritsu MS2724B	1	9 kHz to 20 GHz
	Anritsu MS2721B	1	9 kHz to 7.1 GHz
	Keysight N9914A	1	5 kHz to 6.5 GHz
	Anritsu MS2690A	1	50 Hz to 6 GHz
Vector network analyzer	Agilent E5071C	1	300 kHz to 20 GHz
Broadband field meter	Narda NBM-550	1	Depending on the probe: <ul style="list-style-type: none"> <li>– 100 kHz to 6 GHz (E field)</li> <li>– 100 MHz to 60 GHz (E field)</li> <li>– 1 Hz to 400 kHz (E, H field)</li> </ul>
Vector signal generator	Agilent E8267D	1	250 kHz to 20 GHz
	R&S SMU200A	4	100 kHz to 6 GHz (1 channel) 100 kHz to 3 GHz (2 channels) 100 kHz to 2.2 GHz (1 channel) 100 kHz to 2.2 GHz (1 channel)
	R&S SMBV100A	1	9 kHz to 6 GHz

Baseband generator	R&S AFQ100A	1	System bandwidth: 200 MHz
	R&S AFQ100B	1	System bandwidth: 528 MHz
Receiver	R&S ESMD-SHF	1	20 kHz to 26.5 GHz
	R&S EM550	4	20 MHz to 3.6 GHz
RF Amplifier	AR 80S1G4	1	800 MHz to 4.2 GHz
	AR 5S1G4	1	800 MHz to 4.2 GHz
	AR 30S1G4	1	0.8 to 4.2 GHz
	AR 50WD1000	1	DC to 1 GHz
	PEA02-1-40	3	20 MHz to 1 GHz
Antenna	Cobham OA2	4	300 MHz to 10 GHz
	R&S HE300 (set of 3 antennas)	1	20 MHz to 200 MHz 200 MHz to 500 MHz 500 MHz to 7500 MHz
	SAS-510-7	2	290 MHz to 7 GHz
	LB-OSJ-0760	1	700 MHz to 6 GHz (dual polarised)
	Cobham XPO2V	2	880 MHz to 2.175 GHz
	R&S HK014	4	100 MHz to 1.3 GHz
	Cobham XPO3V	1	500 MHz to 1300 MHz
	Cobham OA1	1	30 MHz to 512 MHz

Based on the equipment listed above several test beds for automated propagation measurements have been developed. Two examples of these test beds have been presented in the figures below.

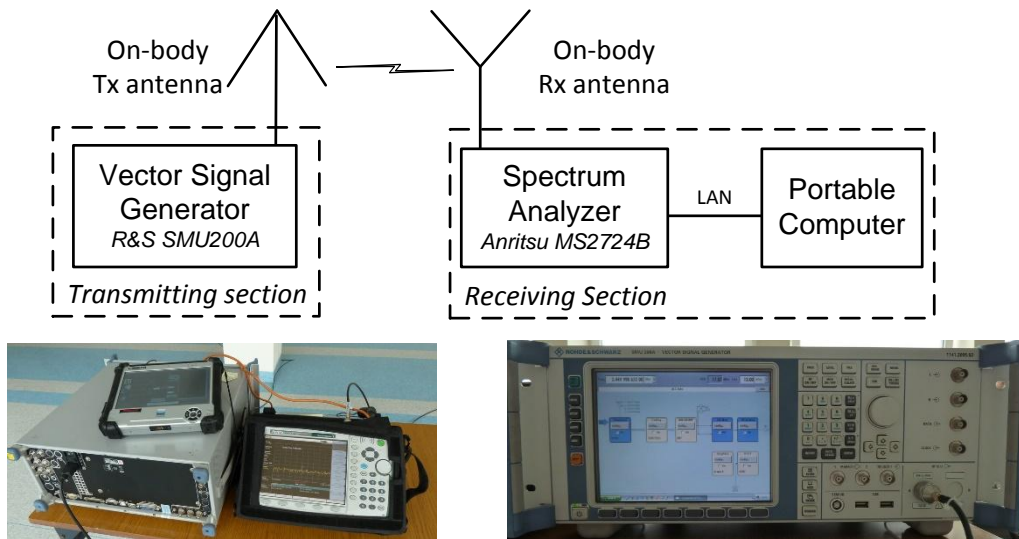

**Fig. 2.1.1. Test bed for measurements of body-to-body channels**



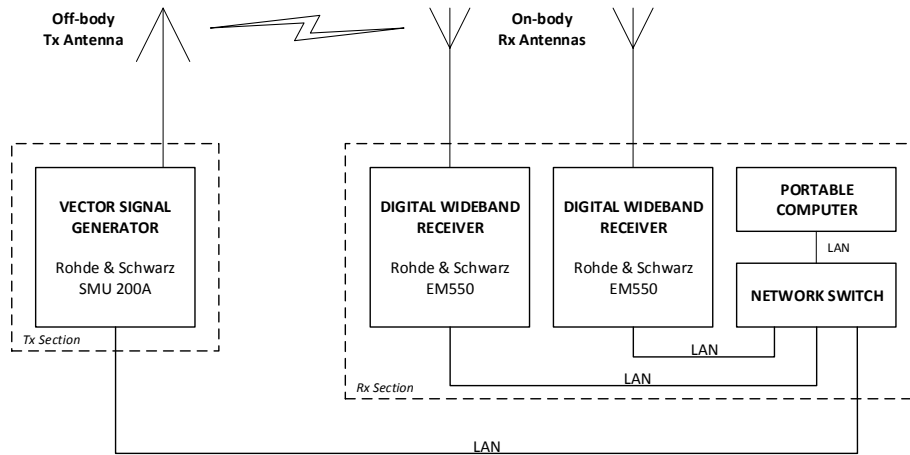

**Fig. 2.1.2. Testbed for measurements of off-body channels with antenna diversity**

The results achieved by using the presented equipment have been presented in the following TDs:

- TD(16)01003, "Radio Channel Measurements in Body-to-Body Communications in Different Scenarios",
- TD(16)02002, "Characteristics of the Polarised Off-Body Channel in Indoor Environments",
- TD(17)03006, "An Approach to Mean Path Loss Model Estimation for Off-Body Channels",
- TD(17)05013, "Radio Channel Measurements in Off-Body Communications in a Ferry Passenger Cabin".

For the IRACON members the equipment of the RADIOCOM@GUT-RWPL can be used for free, but only on site (in Gdańsk, Poland), e.g. under STSM scheme, and only for non-commercial academic purposes.



## 3. EWG-IoT: Internet-of-Things

The goal of EWG-IoT is to support the evolution of 5G networks through the inclusion of the IoT component, via the investigation and assessment of the network architectures, the comparison among the many approaches currently devised for the development of an ecosystem of the IoT platforms and applications in terms of operating systems, and the experimental validation of different protocols for large scale applications of the IoT.

The experimental facilities made available by partners are described below.

### 3.1 FIT/CorteXlab

CorteXlab (<http://www.cortexlab.fr>), as part of the Future Internet of Things (FIT, <https://fit-equipex.fr/>) french funding, is a new testbed made of about 38 software defined radio (SDR) nodes. The main objective is to enable users to run real-time communications with custom APP (application such as traffic generation), MAC (medium access control) and PHY layers implementing state-of-the-art (WiFi, Zigbee, LTE, LTEA.) and upcoming (5G) standards and the programmability of the testbed is a key factor of success.

Large-scale cognitive radio testbeds are required to develop and evaluate the performance of upcoming PHY/MAC layers and future cognitive radio algorithms. Unfortunately, testing new algorithms on real testbeds is complex and time-consuming. While many groups deployed their own facilities, comparing algorithms and techniques in different setups while ensuring reproducible experiments appeared not yet accessible.

Whereas numerous testbeds are available in the field of wireless communications (sensor or 802.11-oriented), only a few large-scale testbeds have been developed having full SDR and cognitive radio capabilities. Apart from on-going projects such as **CREW** (<http://www.crew-project.eu>) or **TRIAL** (<http://www.tekes.fi/programmes/trial>) and some small testbeds involving less than 10 nodes, we found only two testbed developed respectively at Rutgers University, **ORBIT** (<http://www.winlab.rutgers.edu/docs/focus/ORBIT.html>) and at Virginia Tech., **CORNET**, where USRP2 have been dispatched in the ceilings. On both cases, the registered users can remotely program and run experiments on the USRP2.

The CorteXlab testbed is complementary to those of CORNET and ORBIT through the shielded room that targets reproducibility and control over the radio propagation and through the heterogeneity of the nodes. The room is indeed completely faradized on the 6 faces and EM wave absorbing foams cover all walls and roof. Measurements showed that an attenuation of more than 80dB is ensured in the band [500MHz-5GHz].

The CorteXlab facility offers a 167 m<sup>2</sup> EM shielded room and integrates a set of 22 USRP from National Instrument, 16 picoSDR nodes from Nutaq. CorteXlab is built on the network architecture developed for the SensLAB testbed and exploits the free and open-source toolkit GNU-radio. All nodes are remotely accessible through a software interface called Minus.

We chose to mix two types of nodes: general-purpose CPU nodes and FPGA-based



SDR nodes because it could address two different needs. The former (typically USRP) are able to run GNU radio, an open source environment, for rapid prototyping at slow data rates, while the later should be able to run advanced MIMO PHY layers. The difference between both nodes relies on the size of the FPGA and the availability to program it.

The USRP N2932 counts with a wideband RF front-end with the following characteristics:

- Transceiver frequency can be set from 400 MHz to 4.4 GHz,
- A GPS disciplined clock based on the OCXO technology, guarantees a precision of up to 0,01 ppb,
- A total of 20 MHz of bandwidth for wideband operation,
- Noise figure of 5 dB,
- Output power of up to 100 mW, more than enough for the environment of the experimentation room.

Two models of Nutaq PicoSDR nodes are deployed:

- The PicoSDR 2×2 (12 nodes total) is composed of a Perseus 6011 carrier board equipped with a Virtex-6 FPGA, a Radio420M FMC stack and a  $\mu$ TCA backplane board for the Perseus and Radio420M operation.
- The PicoSDR 4×4 (4 nodes total) is composed of two Perseus 6011 carrier boards equipped with a Virtex-6 FPGA, two Radio420M FMC stacks and a  $\mu$ TCA backplane board for the Perseus and Radio420M operation.

The deployment of a scenario follows the following workflow: the remote user connects to the virtual machine "Airlock" which is the only machine an end user can reach through SSH. From Airlock, the user has access to his home directory and uses the tools provided by CorteXlab to compile his code and generate the scenario description file. When ready, the user sends a task request to Minus which schedules and installs the code on the nodes.



**Fig. 3.1.1. The CorteXlab room**

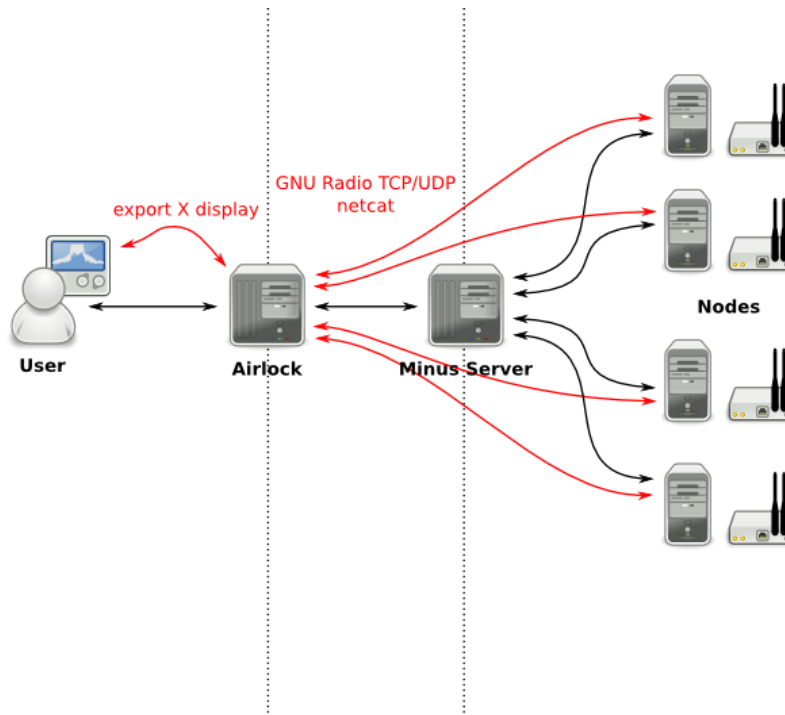

**Fig. 3.1.2. The associated programming workflow using GNU Radio on each nodes**

The testbed is freely available from anywhere by ssh connexion after having obtained a login on the platform website : <http://www.cortexlab.fr/>. The platform has been presented in IRACON TD1703,3rd TM – Lisbon, Portugal, Feb 1– 3, 2017 (<http://www.iracon.org/wp-content/uploads/2016/03/TD1703077.pdf>).

To the best of our knowledge, CorteXlab is the first facility offered to the research community allowing to remotely experiment cognitive radio scenarios in a completely reproducible environment. Compared to existing facilities, CorteXlab provides two important new features: the first is the coexistence of heterogeneous technologies and the second is the shielded room. Last but not least, the co-existence of simple low power wireless sensor networks (IoTlab WSNs) together with complex software radio nodes open the door for new original and complex scenarios. For instance, when the software radio nodes are programmed to evaluate different resource sharing algorithms, interference and thus reproducibility is ensured. But the software radio nodes can also be used to generate a specific interference environment in which the robustness of routing protocols in IoTlab WSNs could be evaluated.

### **3.2 IMEC w-iLab.t**

The w-iLab.t testbed includes both wireless mesh and sensor network infrastructure. These networks can interact with each other, making it possible to test advanced scenarios such as using the mesh network as a backbone for the sensor network. Further, interference between both networks can be studied. In order to facilitate the emulation of realistic sensor scenarios and to measure the energy consumption, the testbed is equipped with a custom designed hardware solutions, called the Environment Emulator (EE). Using the EE, it is possible to emulate the behavior of any type of sensor or actuator without the need for real sensor/actuator hardware or the development of a full-blown sensor application. It is possible to emulate the battery depletion, depending on the real life power consumption of the sensor node. When the node's battery is depleted or the node is destroyed (e.g., in an explosion),



the node can be switched off. The EE can be programmed to emulate a sensor event (e.g., temperature rise, motion detection), an actuator event or to support voice streams. Further, the EE can be used to monitor the energy consumption of each individual sensor. Altogether, this means that it is possible to assess the complete usability of a certain wireless sensor and actuator network application or protocol in a real-life environment. The initial core of w-iLab.t was based on the widely used MoteLab testbed from Harvard University.

The IMEC w-iLab.t testbed is equipped with 60 wireless nodes : IEEE 802.11a/b/g/n, IEEE 802.15.4, IEEE 802.15.1 (Bluetooth) interfaces, software defined radio platforms (USRP) and spectrum scanning engines developed by IMEC. In addition, it offers mobile nodes to the experimenters. These mobile nodes feature the same equipment as the fixed ones, however, they are mounted on a Roomba vacuum cleaning robot. This facility is located in Zwijnaarde, Belgium.

Additionally, w-iLab.t is equipped with a shielded wireless environment. This environment is built up by 4 shielded boxes in which an iNode is installed. The iNodes are interconnected between the boxes by coax cables via a variable attenuator. By varying the signal attenuation, node mobility can be simulated in a repeatable way.

Every w-iLab.t node is generic and is equipped with one or more sensor nodes, an intermediate node with 2 WiFi 802.11 radios, the environment emulator, and a bluetooth interface.

The sensor nodes are Tmote Sky nodes that use a Tiny OS development environment. They consist of a TI MSP430 processor running at 8 MHz, 10 Kb of RAM, 1 Mbit of Flash memory and an IEEE 802.15.4 compliant Chipcon CC2420 radio operating at 2.4 GHz with a maximum indoor range of approximately 100 meters. Each node includes sensors for light, temperature, and humidity. The hardware setup is extendable with a large variety of other radios (e.g., Software Defined Radio, sensing engine), as long as the radio has a USB or RS232 serial interface.

The intermediate nodes (called iNodes) are Alix 3C3 devices running Linux. These are mini PCs equipped with Ethernet, USB, serial, VGA, audio and two IEEE 802.11 a/b/g interfaces. All the iNodes are connected to the management backbone using Power-over-Ethernet switches, making it possible to power up/down the iNodes as needed without physical interaction with the iNodes. The iNodes can become an active member of the experiment as it is possible to adjust the kernel, the driver, to add click router code or to add java-based applications.

Finally, the Environment Emulator is located in between the iNode and the sensor node.

For the COST IRACON members, the w-iLab.t can be used for free but under best effort conditions. A free account can be requested only for non-commercial academic purposes. The testbed is remotely accessible.

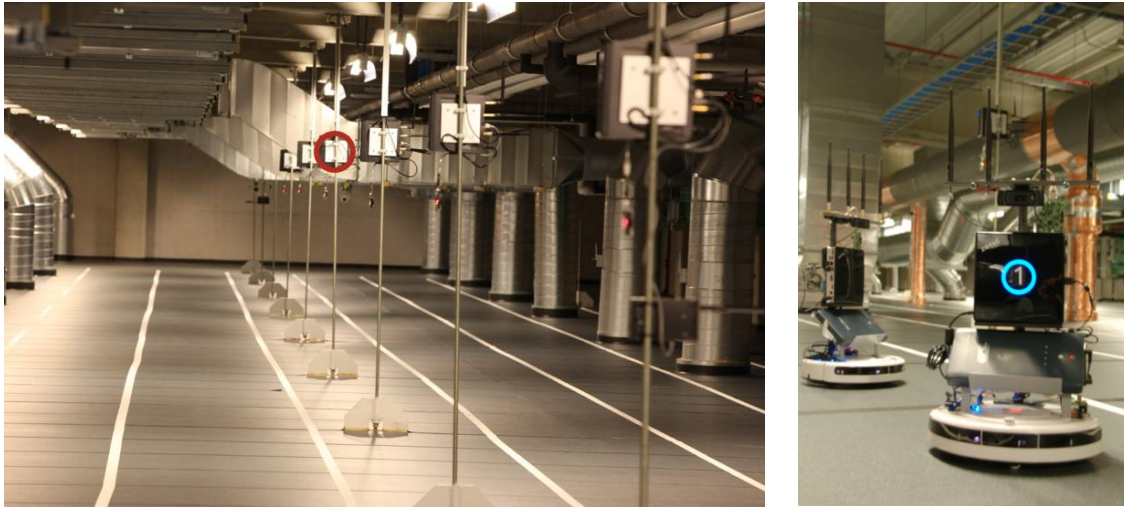

**Fig. 3.2.1. Exemplary view of the w-iLab.t testbed**

### **3.3 EuWIN@Bologna**

The EuWin@UNIBO site developed at the University of Bologna provides approximately 150 wireless nodes using different types of radio interfaces, and deployed according to three different platforms:

- 1) Flexible Topology Testbed (FLEXTOP) – 100 nodes equipped with IEEE 802.15.4 radios distributed inside the lab creating a flexible platform for emulating several types of network topologies, achieved through proper software setting of the inter-node losses.
- 2) Data Sensing and Processing Testbed (DATASENS) – An infrastructure of approximately 50 battery-supplied mobile nodes (with 802.15.4 devices) carried by people moving around, are part of the testbeds (Roaming Nodes).
- 3) LoRa Testbed – A LoRaWAN Gateway will be mounted on the tower of the Engineering faculty at the University of Bologna and some LoRa boards will be available for experimentation.

As far as the FLEXTOP platform, Texas Instruments (TI) devices are located into boxes in a corridor at the University of Bologna (see figure 3.3.1): thirteen boxes are present with 4 devices each. The other 50 devices available can be plugged into whatever positions inside the lab. Devices are TI CC2530 system on chips, with 256 KB internal flash and 256 KB external EEPROM, 8 KB of RAM, a transmit power within [0, 20] dBm and a receiver sensitivity of -85 dBm.

The main strength of FlexTop is that the experimental environment is stable for the total duration of the experiment, thus making the results replicable, based on: 1) nodes are at fixed and known positions; 2) channel gains between each pair of nodes are measured at the beginning of each test; and 3) experiments are performed during the night, when nobody is present, avoiding uncontrollable channel fluctuations. With reference to point 2), and in order to properly describe the environment, before the start of experiments, we measured the average received power matrix  $\mathbf{P}$ . The generic element of  $\mathbf{P}$ , denoted as  $P_{i,j}$ , represents the average power received by node  $i$ , when node  $j$  is transmitting. The matrix is obtained as follows: each node, including the coordinator, sends a burst of 10 000 short packets to let other nodes compute the average power received. We consider two nodes as connected if the percentage of packets received over the link is larger than 90%. Therefore, if more than 90% of packets are received over the link, we compute the average received power that is

included in the matrix; if a larger number of packets is received, the two nodes are considered as not connected. The links are rather stable, therefore the 90% threshold is actually not relevant, as links either exist or do not.

On the platform it is possible to test different protocols stacks, such as Zigbee, 6LoWPAN, 6TiSCH, and proprietary solutions. Moreover, a software-defined networking-based (SDN) architecture is also made available: The IoT coordinator is remotely connected to an SDN controller, able to program IoT devices in terms of PHY and MAC parameters, such as topologies. Changing policies at the Controller, different topologies and routing algorithms can be simply tested on the platform.

All the platforms cited above are available for free on site at the University of Bologna. UNIBO may also provide some devices to partners to let them work on their institutions.

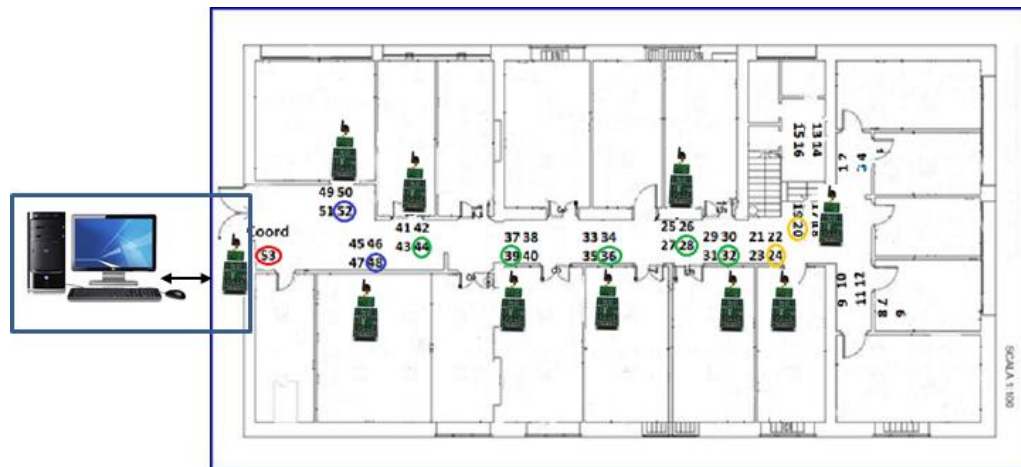

**Fig. 3.3.1. The FLEXTOP platform: devices map.**

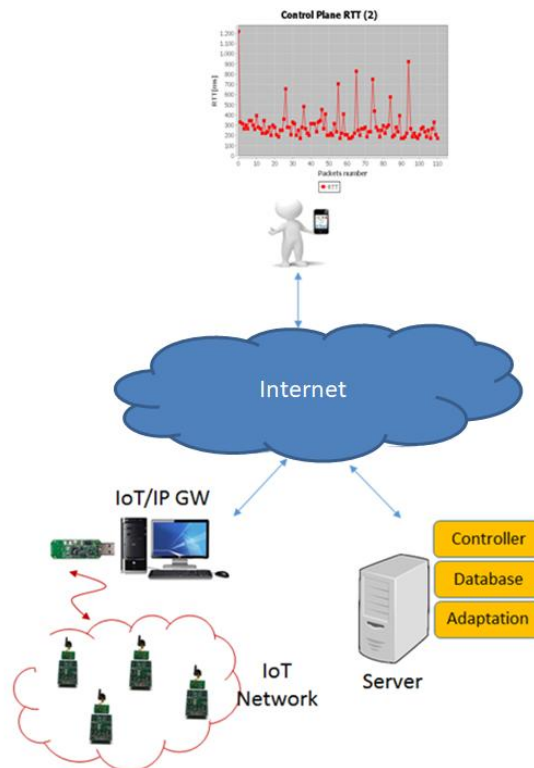

**Fig. 3.3.2. The FLEXTOP platform: architecture**



## **3.4 Resource for Vehicle Research (Revere)**

Revere ([www.chalmers.se/en/researchinfrastructure/revere](http://www.chalmers.se/en/researchinfrastructure/revere)) is a research infrastructure targeting research on traffic safety, automated driving, and vehicle dynamics. The connection with internet of things is simply that connected vehicles (cars, trucks, buses, motorcycles, etc.) are moving sensor platforms (things) that are attached to the Internet. Connectivity brings many advantages, such as enabling application under the umbrella of Cooperative Intelligent Transport Systems (C-ITS). These applications are typically divided into two classes: traffic safety and traffic efficiency applications. The former class of applications simply aims to reduce the number and impact of accidents, while the latter aims to reduce fuel consumption, harmful emissions, and increase utilization (traffic flow) of the road infrastructure. In addition to C-ITS, connectivity also enables high-performance automated driving, access to cloud services, and Internet access for both the vehicle itself and its passengers.

Revere is hosted by Chalmers University of Technology. In addition to Chalmers, partners are SAFER Vehicle and Traffic Safety Centre, Volvo Cars, and Volvo Trucks. Partial financing is provided by Region Västra Götaland.

In addition to the lab space and equipment detailed below, Revere provides support for the complete project chain: from initial idea through project funding proposal, project planning, software and algorithm development, simulations, test set-up, vehicle installation, validation on a test track or in real traffic, to final evaluation of project results.

The Revere laboratory provides vehicles and a research platform for development and verification of theoretical models, algorithms and technologies both in real traffic environments and in simulators. Tests in different traffic environments can be carried out in close cooperation with the test facility AstaZero (<http://www.astazero.com/>).

Revere has a lab space of approximately 400 m<sup>2</sup> located at Lindholmen Science Park in Gothenburg, close to Chalmers Lindholmen campus, see figure below. The lab space has a small office with desks and meeting facilities and a larger workshop where vehicles can be prepared and serviced.





**Fig. 3.4.1. ReVeRe Office and workshop space**

In addition to the lab space and support with project management and technical issues, Revere resources include

- Passenger car: Volvo XC90,
- Truck: Volvo FH16 tractor,
- Dolly: Parator with steerable axles,
- Driving simulator,
- Open DLV (open-source software for driverless vehicles) .

The passenger car is a Volvo XC90 2.0 T6 AWD, which is an inline 4-cylinder 316 horsepower gasoline SUV with an 8-speed geartronic automatic transmission and air suspension, see Fig. This test vehicle can be equipped with virtually any kind of sensor or software to test active safety systems, automated driving, and vehicle dynamic systems. Full access to the vehicle's network is available, enabling full actuation, e.g., steering, acceleration and braking.



**Fig. 3.4.2. ReVeRe XC90 passenger car**

The truck is a Volvo FH16, 750 horsepower 6x4 tractor with dynamic steering and I-shift transmission, see figure below. It has a liftable driven rear axis and a low chassis, optimized for long vehicle combinations. This test vehicle can be equipped with virtually any kind of sensor or software to test active safety systems, automated driving, and vehicle dynamic systems. An external power supply can be mounted on the vehicle to achieve a stable platform for data collection.



**Fig. 3.4.3. ReVeRe FH16 truck**

The Parator dolly is an unpowered vehicle used to connect with a prime mover for very long tractor-trailer combinations, up to 32 meters and 90 tons, see figure below. The two axles can be steered individually, which a unique functionality. The dolly can be equipped with different kinds of sensors, e.g., cameras, radars, lidars, and computers. Moreover, wireless sensors for measuring the angle between the dolly and the trailer can be mounted on different locations. An external power supply can be mounted on the vehicle to achieve a stable platform for data collection.



**Fig. 3.4.4. ReVeRe Parator dolly**

The driving simulator is mounted on a 6 degree-of-freedom motion platform: three linear movements (x, y, and y) and three rotations around these axes (roll, pitch and yaw), see figure below. The simulator is equipped with motion cueing for increased perception and realism. Different car models from carMaker are available to get a realistic testing environment. The advantages with simulator testing is efficiency, high level of controllability, and risk-free and ethically accepted environment for exposing test participants to critical situations. The simulator has been developed in collaboration with the Swedish National Road and Transport Research Institute (VTI)



and Chalmers. There are plans for further develop the simulator to include the possibility to remote control a vehicle from the simulator as well as experience an augmented reality through 3D glasses.



**Figure 1: ReVeRe driving simulator**

Partnership gives access to Revere's Open Source Software for driverless vehicles, which is a software framework developed to be used in self-driving research vehicles. The software is vehicle and vehicle type independent and handles hardware communication, safety and override functions, sensor fusion, decision making and visualization. Moreover, it has support for seamless simulation and can be run in a 2D- or 3D-graphical simulation environment. Interfaces to other systems like Micro Autobox are also provided. The software is mainly written in C++ and is developed with focus on safety and data security. New versions of the software can be easily deployed.

The facility is available for Chalmers researchers, but Revere is also open to requests from researchers from other universities, institutes, and companies. There is cost for using the facility depends, of course, on the project.

Contact person for inquiries: Lab Manager Fredrik von Corswant, [Fredrik.Von.Corswant@chalmers.se](mailto:Fredrik.Von.Corswant@chalmers.se)

### **3.5 BAAL@ITU (Computer Networks Research Laboratory @ Istanbul Technical University)**

The aim of the IoT testbed is to focus on the performance and security of the IoT deployments.

The available equipment includes:

- 18× Texas Instruments Sensortags (TI Sensortags have IEEE 802.15.4 and Bluetooth support.)
- 10× Raspberry Pi's (WiFi support.)
- 6× Texas Instruments MSP430 experimental boards (802.15.4, WiFi and Bluetooth support with external antenna.)
- 5× Intel Galileo boards
- Several launchpads for TI MSP430 (requires external antennas and external sensors for communication.)

Moreover, several wireless sensor nodes and conventional routing/networking equipment is readily available. The testbed is previously used effectively in many measurement, experimenting occasions including solely IoT deployments or

IoT/cellular hybrid deployments.



**Fig. 3.5.1.** On the bottom left, a wireless sensor node. Intel Galileo board is at the center-left. TI MSP430 experimental kit is at the center-right. Right over that, TI sensortag is placed. Raspberry Pi is in a black case at the bottom right.

### **3.6 RADIOCOM@GUT-HMS**

The heterogeneous mobile stand (HMS) of the Department of Radio Communication Systems and Networks (RADIOCOM) at Gdańsk University of Technology (GUT) includes hardware and software developed nodes and data acquisition server (DAS). Three types of devices were developed:

- reference node (RN) with dimensions of 130 mm × 35 mm × 31 mm and connected via a wired RS232 interface to the DAS (fig. 3.6.2);
- miniaturized mobile nodes (MN) with dimensions of 58 mm × 16 mm × 35 mm and can be attached i.e. to the human body (fig. 3.6.3);
- computer with dedicated software is used as DAS, which (beside saving data to files) monitors measurement equipment by displaying information, among others, number of devices in network, operation mode, the actual distances between the nodes, and so on.

Each node consists of two parallel working radio interfaces:

- narrowband (NB) radio module CC1120 produced by Texas Instruments company, working in the 868 MHz band (UHF), used to determine i.e. the propagation attenuation;
- ultra-wideband (UWB) radio module DWM1000 produced by DecaWave company, working in the 6489 MHz band (SHF), used to perform the radio distance measurements and channel impulse response estimation.

In fig. 3.6.1 the sample diagram of the heterogeneous measurement stand connections is shown.

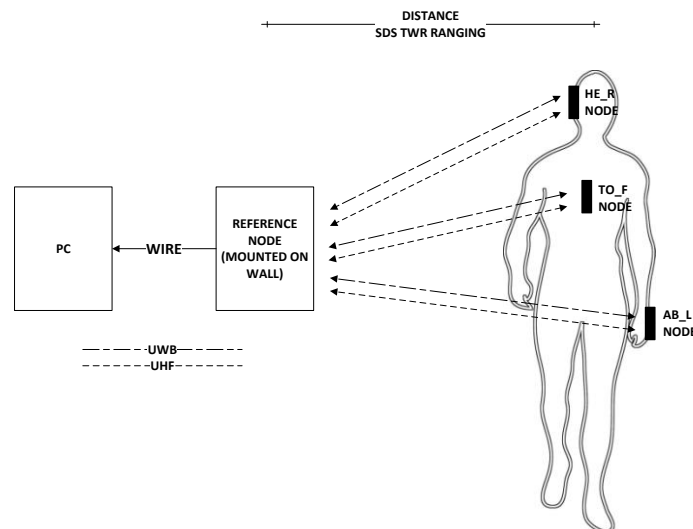

**Fig. 3.6.1. Sample diagram of the heterogeneous measurement stand connections.**

Wireless protocol solutions using both radio interfaces, their self-organization methods, data exchange, time division multiple access (TDMA) and physical layer based on microcontrollers are implemented.

To estimate the distance between two nodes, UWB interface and the method of Symmetric Double-Sided Two-Way Ranging (SDS-TWR) which minimizes local oscillators drift and increase accuracy through the exchange of three measurement packets were used. Radio distance measurements allow to automate the measurement process. Time synchronization of both radio interfaces, using a dedicated signal line, allows to obtain information about the path attenuation and the corresponding distance between the transmitter and receiver at once. All measured data can be recorded and analyzed independently of the person's speed in different scenarios.

The results achieved by using the presented equipment have been presented in the following TDs:

- TD(17)04008, "Radio Channel Measurements in 868 MHz Off-Body Communications in a Ferry Environment",
- TD(17)04016, "Novel Adaptive Method for Data Streams Allocation Based on the Estimate of Radio Channel Parameters in Heterogeneous WBAN Network"

For the IRACON members the equipment of the RADIOCOM@GUT-HMS can be used for free, but only on site (in Gdańsk, Poland), e.g. under STSM scheme, and only for non-commercial academic purposes.





**Fig. 3.6.2. Top view (upper) and bottom view (lower) of the reference node.**

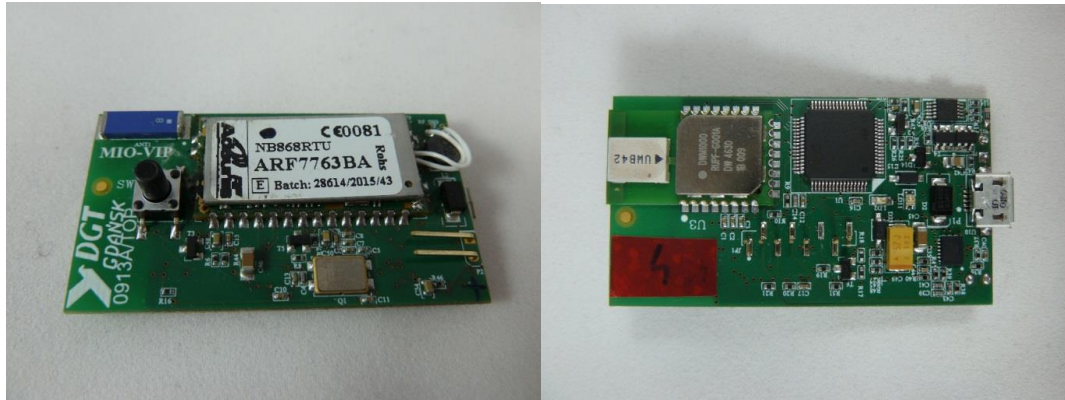

**Fig. 3.6.3. Top view (left) and bottom view (right) of the mobile node.**

### **3.7 UNIBL-IoT Lab**

The objectives of IoT testbed at the premises of University of Banja Luka, Faculty of Electrical Engineering, are to enable various research activities in the area of Wireless Sensor Networks (WSN) and Internet of Things (IoT). Currently, IoT testbed is based on OpenMote WSN hardware devices. The OpenMote is a representative of new generation open-hardware platforms that is particularly adapted to Industrial Internet of Things (IIoT) applications. IoT testbed consists of 10 OpenMote nodes and 4 desktop computers. Desktop computers are used to connect OpenMote nodes to Internet and for purpose of WSN management and processing of measurement data.



### Fig. 3.7.1. The OpenMote-based IoT testbed

The OpenMote hardware is shown in figure below. It is composed of four boards: OpenMote-CC2538, OpenBase, OpenBattery and OpenUSB.

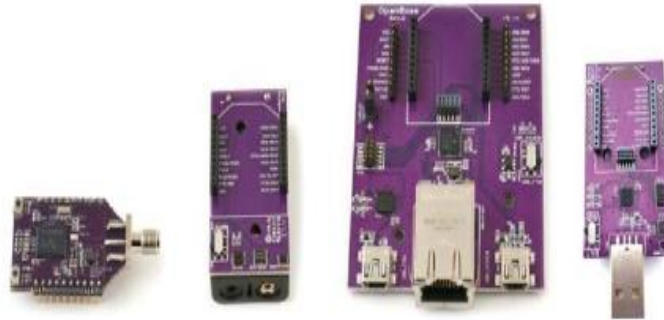

### Fig. 3.7.2. OpenMote hardware

The OpenMote-CC2538 is based on TI CC2538 SoC functionalities and has the following peripherals: step-down DC/DC converter, two crystal oscillators at 32 MHz and 32.768 kHz, 4 LEDs, antenna connector and two buttons (one is used to reset the board and the other enables wake up the microcontroller from sleep modes through an interrupt). The OpenMote-CC2538 is based on 32-bit Cortex-M3 microcontroller that runs up to 32 MHz and includes 32 Kbytes of RAM, 512 Kbytes of Flash and common peripherals (GPIOs, ADC, timers, etc.). The radio operates at the 2.4 GHz band and is fully compatible with IEEE 802.15.4-2006 standard. The OpenMote-CC2538 is also fully compliant with the XBee form factor.

The OpenBase is the board that serves three different purposes. First, it enables programming and debugging by using a probe with a standard ARM JTAG connector (10-pin), e.g., the Segger J-Link debug probe. Second, it enables the communication with a computer through the serial port or USB port in order to support programming and debugging. The serial port, which is interfaced through an FTDI FT232R chip, enables both programming and debugging. Third, it provides the communication via 10/100 Mbps Ethernet port, thus enabling the Internet connection to OpenMote-CC2538. The OpenMote-CC2538 is connected to the OpenBase using the XBee header.

The OpenBattery provides the supply to all OpenMote-CC2538 subsystems, as well as the interface to various sensors. The OpenMote-CC2538 is connected to the OpenBattery using the XBee header and has a 2xAAA battery holder. The OpenBattery includes a switch to power on/off the board, as well as three different digital sensors: a temperature/humidity sensor (SHT21), an acceleration sensor (ADXL346) and a light sensor (MAX44009). The OpenUSB is designed for ease-of-use by ends users, and for using OpenMote-CC2538 boards in a testbed.

Since OpenMote-CC2538 radio interface supports only IEEE 802.15.4 standard at physical layer, in IoT testbed is possible to use only those communication protocol-stacks that are based on IEEE 802.15.4 standard. The IoT testbed currently uses OpenWSN protocol-stack and Contiki.

OpenWSN protocol-stack is a newly released open-source implementation of a fully standards-based protocol stack for IoT capillary networks, rooted in the new IEEE 802.15.4e TSCH standard, as shown in the next figure. It is developed as part of OpenWSN project. OpenWSN implements, on top of IEEE 802.15.4e, IoT standards

such as IPv6 over Low power Wireless Personal Area Networks (6LoWPAN), Routing Protocol for Low power and Lossy Networks (RPL) and Constrained Application Protocol (CoAP), thus enabling a seamless network connectivity to the IPv6 Internet. The IEEE 802.15.4e TSCH standard replaces the traditional IEEE 802.15.4 MAC protocol, without changing the underlying physical layer.

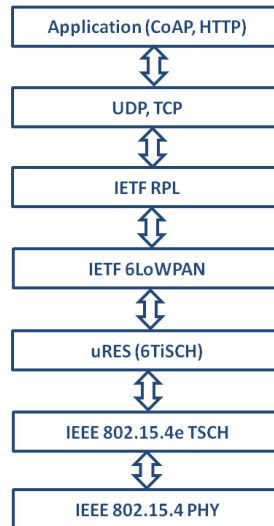

**Fig. 3.7.3. OpenWSN protocol stack**

OpenVisualizer (OV) is also developed as a part of OpenWSN project. OV is a Python-based debugging and visualization program for OpenWSN networks that resides on desktop computer. OpenBase with OpenMote-CC2538 attached to it can be connected to desktop computer via USB emulated serial interface. When OpenBase is connected to desktop computer, the OV creates IPv6 TUN (network TUNnel) interface that is a virtual IPv6 interface tunneled through the serial port. This interface enables the communication between OpenMote-CC2538 devices in WSN network and IPv6 Internet. The visualization is realised through Graphical User Interface or Web interface and provides insight into status of motes and mote management functions (only for mote directly connected to host), such as: declaring mote as DODAG root, viewing routing topology if the mote is declared as DODAG root, display operating parameters (Radio Duty Cycle (RDC), queue status, neighbor table, IPv6 address, number of active time slots in slotframe, etc.) and packet capturing using e.g. Wireshark. The desktop computer is running Ubuntu 16.04 LTS.

The IoT testbed is also available for research to students of Faculty of Electrical Engineering, University of Banja Luka, and partnership universities.

UNIBL-IoT Lab is also equipped with following devices:

- RASPBERRY PI 3 - MOD B - 1 GB,
- Ultimate Starter Kit for Arduino ADA010,
- ESP8266 ESP-12E UART WIFI Wireless Shield TTL Converter,
- Ethernet Shield WizNet W5100 R3 Arduino Mega.





**Fig. 3.7.5. Raspberri Py and Arduino platforms**

The results achieved by using the presented equipment have been presented in the following TDs:

- TD(16)01014, “Testing OpenWSN and Contiki OSs Performances on OpenMote Platform”, Gordana Gardašević, Dragan Vasiljević, Mladen Veletić;
- TD(17)03022, “Experimental Characterization of Joint Scheduling and Routing Algorithm over 6TiSCH”, Gordana Gardašević, Dragan Vasiljević, Chiara Buratti, Roberto Verdone;
- TD(17)04077, “Development of minimum cost forwarding (MCF) and source routing MCF routing protocols over 6TiSCH in OpenWSN”, Fardin Derogarian, Gordana Gardasevic and Fernando J. Velez;
- TD(17)05027, “A Heterogeneous IoT-based Architecture for Remote Monitoring of Physiological and Environmental Parameters”, Gordana Gardašević, Hossein Fotouhi, Ivan Tomasic, Maryam Vahabi, Mats Bjorkman, and Maria Linden.

## 4. EWG-LT: Localisation and Tracking

The goal of this EWG is to follow the development of 5G standardisation, taking advantage of the new techniques implemented and defined (millimetre waves, massive MIMO, etc.) to design and test new localisation and tracking techniques for devices, working both in outdoor and indoor environments.

The experimental facilities made available by partners are described below.

### 4.1 RADIOCOM@GUT-LMS

The localization measurement stand (LMS) developed in the Department of Radio

Communication Systems and Networks (RADIOCOM) at Gdańsk University of Technology (GUT). The measurement stand is designed for developing localization systems and algorithms for hybrid localization systems dedicated for operation in harsh and indoor environments. It was assumed, that determination of position estimates of a moving person will be based on inertial and radio distance measurements.

Constructed measurement stand consists of personal monitoring unit, named PMU, placed on a foot of moving person and reference nodes (RN) used as reference points during radio distance measurements. PMU realizes measurements of movements parameters like linear accelerations, angular velocities, vector components of the Earth's magnetic field and selected parameters of radio waves used for determining distance to reference nodes.

Central point of the stand is a personal computer for data registration and visualization (SRV). In fig. 4.5.1 a block diagram of personal monitoring unit and reference node was presented. Each device consists of a computational unit, inertial sensor and two communication radio modules. The need of performing multiple numerical calculations in inertial navigation algorithms requires the use of advanced 32-bit ST microcontroller STM32F405, equipped with an ARM Cortex-M4 core, with support for single-precision floating point calculations. The main role of computational unit is to analyze movement parameters measured by inertial measuring unit and determine, by using implemented inertial navigation algorithm, position of a person. The second role of this unit is to control UWB (*Ultra-Wide Band*) radio module DWM1000, from DecaWave, during radio distance measurements (realized by using SDS-TWR method) with respect to designed communication protocol. It is worth to notice, that UWB module operates on 6.489 GHz center frequency with 499.2 MHz of occupied band.

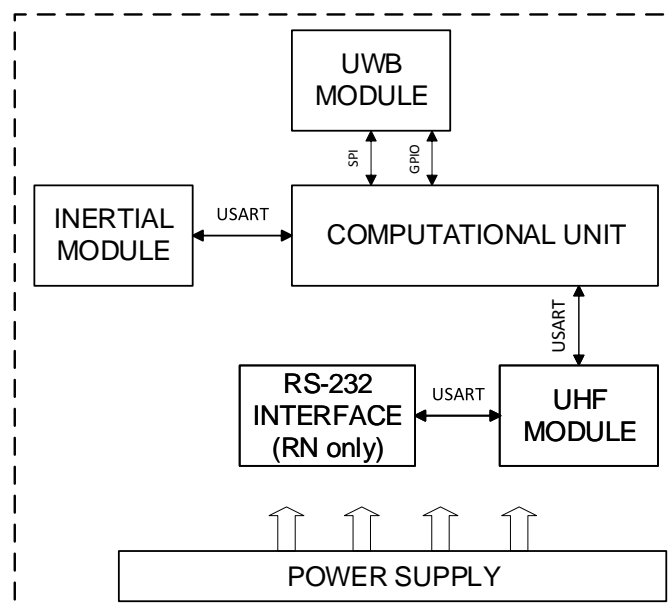
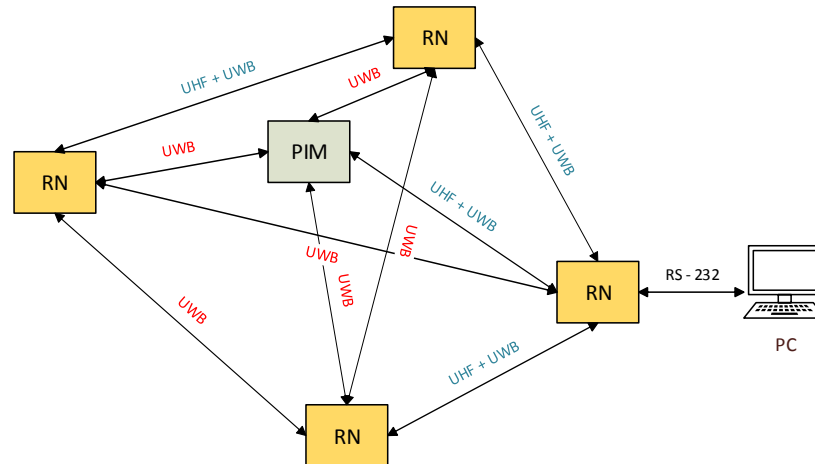

**Fig. 4.5.1. Block diagram of personal monitoring unit and reference node**

Results of measurements performed by PIM are sent to SRV by using narrowband radio interface that operates on UHF (*Ultra High Frequency*) frequency 868 MHz.

Coexistence of several reference nodes and personal monitoring unit needs an implementation of radio communication protocol for organizing data exchange in UHF and UWB radio interfaces. It was assumed, that multiple access to the radio channel will be organized by using TDMA (*Time Division Multiple Access*) technique. Each node has its time slot in which it can transmit data to other nodes.

Both radio interfaces are time synchronized, that means transmission in one time slot is simultaneous in each radio interfaces. In fig. 4.5.2 a block diagram presenting network organization and data exchange in hybrid localization system was shown.



**Fig. 4.5.2. Block diagram of network organization and data exchange in hybrid localization system**

Developed devices are a part of a prototype of hybrid localization system (fig. 4.5.3), that allows moving people monitoring by using inertial navigation and radio localization algorithms. In addition, dedicated software written in C# language and MATLAB simulation environment was developed for positional data registration and analysis.

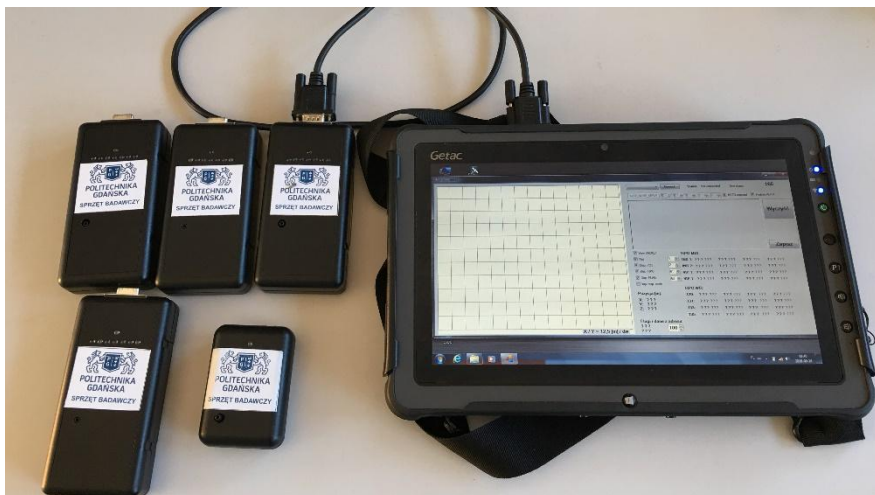

**Fig. 4.5.3. Prototype of hybrid localization system**

The results achieved by using the presented equipment have been presented in the following TD:

- TD(17)05015, "New Method for Increasing Precision of Position Estimation of a Moving Person in Hybrid Inertial Navigation System".

For the IRACON members the equipment of the RADIOCOM@GUT-LMS can be used for free, but only on site (in Gdańsk, Poland), e.g. under STSM scheme, and only for non-commercial academic purposes.

## 4.2 LOG-a-TEC testbed

The LOG-a-TEC testbed has been initial set up in view of performing experiments for Cognitive radio. During the years the testbed has been evolved to support various types of experimentation, namely research and development of indoor/outdoor localization algorithms, spectrum sensing to support cognitive radio and dynamic spectrum access, link and network performance evaluation in controlled interference heterogeneous radio environment, design and evaluation of new custom-developed wireless protocols and their benchmarking against the standardized protocols and performance evaluation and controlled piloting of prototype IoT devices.

The architecture of the LOGa-a-TEC testbed is illustrated in the following figure. Since architecture is instantiated for wireless networks, particularly for 5G capillary technologies, the wireless Target nodes and the Infrastructure nodes are conceptually distinguished, which coupled together form particular testbed devices. Similarly, two parts of automation systems, namely the Repository which holds the code and build scripts and the Infrastructure experimentation and management system are also distinguished.

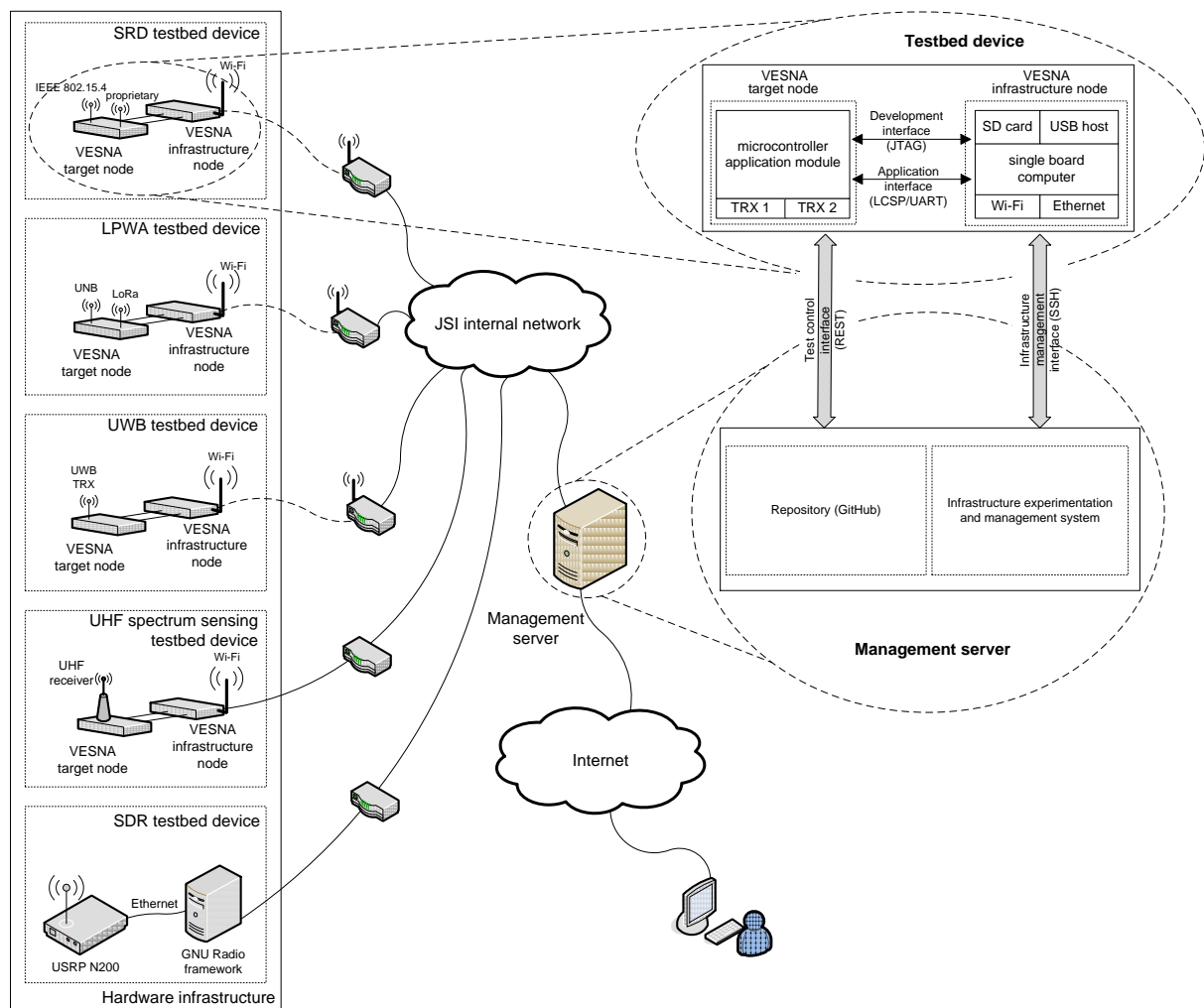

**Fig. 4.6.1. Architecture of the LOG-a-TEC 3.0 testbed**

The hardware infrastructure, depicted on the left side of the figure, is composed of several types of testbed devices. Except for the Software Defined Radio (SDR) testbed device all other devices are comprised of two VESNA (Versatile platform for Sensor Network Applications) nodes, as depicted on the top right part of the figure. Type, properties and number of devices in the LOG-a-TEC testbed are listed in the following table. The Target nodes host several different radio interfaces which can be classified to those enabling experimentation with: (i) LPWA communications, (ii) short range UWB communication, (iii) advanced spectrum sensing in sub-1 GHz



bands, (iv) efficient lightweight protocols in 2.4 GHz and sub-1 GHz bands that are not based on IEEE 802.15.4 (clean slate) and (v) spectrum sensing and signal/interference generation by reconfigurable transceivers.

**Tab. 4.6.1. Testbed devices configuration and features**

Device type	Radio	Frequency	No. of devices
<b>SRD A</b>	Atmel AT86RF212	868 MHz	21 outdoor
	TI CC2500	2.4 GHz	
<b>SRD B</b>	TI CC1101	868 MHz	21 outdoor
	Atmel AT86RF231	2.4 GHz	
<b>LPWA</b>	Semtech SX1272	868 MHz	3 outdoor 1 indoor
<b>UWB</b>	DecaWave DW1000	3.5 - 6.5 GHz (6 channels)	11 outdoor
<b>UHF spec. sens.</b>	NXP TDA18219HN	470 - 866 MHz	2 outdoor
<b>SDR</b>	USRP N200	400 - 4400 MHz	3 indoor
<b>management network</b>	TI WL1837	5GHz	58 outdoor
			21 indoor

The Infrastructure node is based on BeagleCore module running the GNU/Linux operating system, which consists of the Texas Instruments (TI) AM3358 1 GHz ARM Cortex-A8 processor. It has 512 MB DDR3 RAM and 8 GB of eMMC Flash. It supports microSD cards and enables infrastructure connectivity by Ethernet and WiFi operating at 2.4 GHz and 5 GHz bands.

The Target node is based on custom ARM Cortex-M3 microcontroller application modules with dedicated experimentation transceivers. The Target node is connected to the infrastructure node through JTAG programming/debugging interface for programming and debugging of the Target node, and the application interfaces, which is based on protocol LCSP running on top of serial port (LCSP/UART), used for communication while experimentation node is in operation.

The Target nodes are based on constrained embedded devices optionally running a dedicated OS (e.g. Contiki), while the infrastructure nodes are more capable and run Linux OS. The integration of the two is done via custom hardware design and the adoption of selected interfaces and protocol.

The LOG-a-TEC testbed is located at the campus of Jožef Stefan Institute (JSI), and consists of outdoor and indoor segments. The outdoor segment is located in and around the JSI park, which length and with is around 60 m. Nodes in the park are attached to the light poles 3.5 m above the ground. Additional the nodes are placed at buildings which surround the park. The height of nodes attached to the building varies

from 2 to 10 m. The indoor testbed consists of additional 24 nodes, deployed in the second and the third floors of the building with the dimension of 28.4 m by 16.6 m. Several portable nodes are also available for the experiments which incorporate the mobility. The node locations are depicted in the following figure.

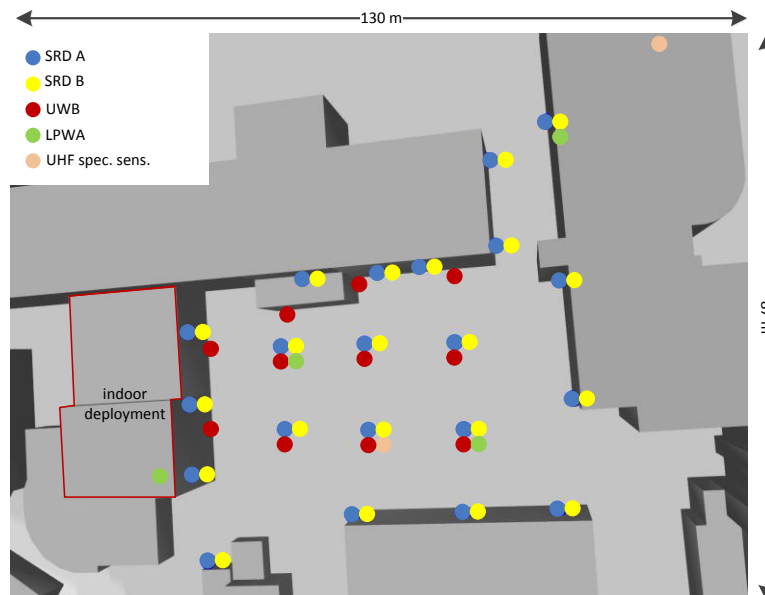

**Fig. 4.6.2. Location of nodes in LOG-a-TEC testbed**

LOG-a-TEC testbed, also a member of Fed4FIRE federation of testbeds, experiment delivery and execution system is based on Ansible and container technology. It combines several features that comprise a complete testbed management, monitoring and experimentation solution. The whole setup is composed of Docker containers with the all dependencies included in each container which enables simple redistribution. The web interface and an HTTP REST API are exposed externally through the management server. Browsing through devices clusters and nodes is enabled through infrastructure management system using web browser which also includes node monitoring information and statistics such as node up time, node location on a map, system load, etc., and gives real time view of the state of the testbed.

REST API is used for the programmatic access to the management system which can be also used by users for accessing the information about the nodes and clusters programmatically.

Infrastructure management system runs the OpenVPN virtual private network service which enables connecting nodes to the infrastructure management system from external networks. In a typical deployment on external networks, nodes are placed behind an IP network address translation (NAT) and/or a firewall that is not under the experimenter's control. This prevents direct IP connections from the infrastructure management system to the services listening on the nodes, such as the Ansible SSH, which is essential for node management. While this could be solved by modifying the firewall rules, this is often frowned upon by network administrators. Hence a more effective solution is to establish a VPN connection to external network nodes.

The experimentation system was designed to abstract the underlying complexity and enable the desired workflow. Everything needed for the experiment is available in a GitHub repository and the experimenter only needs to write the code for the actual experiment performed on the node and the part performed by the experiment



controller. When the experiment is completed, the experiment controller will automatically push the experiment results to GitHub build results, making them available to the experimenter for download and post processing.

An important part of the experiment setup process is the flashing of the experimentation node. This can be done by choosing an existing embedded binary from the list of pre-prepared embedded images suitable for the experiment, or by specifying own source to be compiled for the experimentation node.

The testbed is remotely accessible and available on the side, if it is not previously booked for other experiment. In general, the testbed is for free academic use. However, if an extra support to run experiment or even modification of the testbed is needed by the JSI stuff we expect at least one common publication at international conference or in international journal. The commercial use of experiment will be fully charged. The LOG-a-TEC testbed is a member of FED4FIRE+, thus we suggest the experimenter check for FED4FIRE open call (<https://www.fed4fire.eu/opencalls/>) and submit proposal.

The testbed has been described in the following TD :

- TD(17) 03040, “LOG-a-TEC testbed current state and future plans”.

## 5. EWG-RA: Radio Access

The goal of this EWG is to experimentally validate the many techniques that will be implemented at the PHY and MAC layers of the radio access part of 5G, especially those developed within DWG2. New waveforms, cognitive radio approaches, or massive MIMO, are possible examples.

The experimental facilities made available by partners are described below.

### 5.1 OpenAirInterface

OpenAirInterface ([www.openairinterface.org](http://www.openairinterface.org)) is an open source initiative that today provides a 3GPP compliant reference implementation of eNodeB, User Equipment (UE), and evolved packet core (EPC) that runs on general purpose computing platforms together with off-the-shelf software defined radio (SDR) cards like the ETTUS USRP, Lime SDR, and Ex-pressMIMO2. It allows users to set up a compliant 4G LTE network and inter-operate with commercial equipment.

The objective of OpenAirInterface (OAI) is to allow experimentation with state-of-the-art cellular radio technology (4G and 5G) while preserving full compatibility with commercial 3rd party equipment. The open-source nature of the code allows experimenters to insert their own code easily. OAI uses their own open-source license, the OAI public license 1.1, which is based on Apache 2.0, but includes a clause that makes it compatible with current 3GPP licensing schemes. The OAI software alliance has been created to promote this license and to foster collaboration around OAI.

In this section we firstly describe the “classical” or “monolithic” version of OAI and the existing OAI massive MIMO testbed. Secondly we describe the recently introduced and currently being developed functional splits of OAI that will enable C-RAN deployments of OAI. Last but not least we describe the current state and vision of the C-RAN testbed at Eurecom and how we are planning to map our existing work on massive MIMO onto this new testbed.

#### 5.1.1 Massive MIMO and LTE

Massive MIMO can also be smartly and perfectly fit into the current LTE standard. In fact, 3GPP has defined the notion of “Transmission Modes” (TMs) for different usage of MIMO in LTE such as single antenna transmission (TM1) transmit diversity (TM2), open-loop spatial multiplexing (TM3), closed-loop spatial multiplexing (TM4), etc. Different TMs use different antenna ports, which can then be mapped onto one or more physical antennas. TM7 is defined in Release 8 and uses antenna port 5 to transmit both data and UE-specific pilots to a single user. The beamforming is thus transparent to the user and can be arbitrary. Release 9 extends TM7 to TM8, giving the possibility of transmitting two streams to a single user or two users, whereas in release 10, this is further extended to TM9 where up to 8 layers for a single user transmission and up to 4 layers for multiuser transmission is supported.





Release 11 adds TM 10, similar to TM 9 with up to 8 layers transmission but the transmit antennas can be physically located on different base stations. In Release 13, no new transmission mode is defined, but CSI Reference Signal (RS) has been extended to 16 ports. Moreover, the ongoing work item in release 14 on the enhancement of Full-Dimension MIMO (special case of massive MIMO in 3GPP) for LTE has defined the objective of extending the CSI-RS to 32 ports with enhancement on CSI reports and support for providing higher robustness against CSI impairments.

OAI currently supports TMs 1,2, and 7, and has experimental versions of TMs 3 and 4. TM 8 and 9 are currently in development. OAI does not (yet) support any CSI reference signals, but it does support sounding reference signal (SRS), which can be used in TDD together with a proper reciprocity calibration mechanism to estimate the CSIT.

The Eurecom massive MIMO testbed is based on TDD and TM7 driving up to 64 colocated antenna elements. It uses uplink channel estimates based on the SRS and transforms them with the help of the calibration matrix (see next section) to a downlink channel estimate, which is then used to compute the beamforming weights. During our experiments we were able to establish communication with a commercial UE and achieve the maximum possible throughput for the given configuration.

### 5.1.2 Functional splits in OAI

In the massive MIMO testbed described above, all the eNB functionality was running in the same machine<sup>1</sup> using heavy parallelization to meet the real-time constraints. In order to support a distributed antenna array built from remote radio heads, the monolithic architecture of OAI is split into several parts.

We have adopted the definitions of China Mobile, Alcatel-Lucent, Nokia Networks, ZTE Cooperation, Broadcom Cooperation, and Intel China (“Next generation fronthaul interface,” White paper, Jun. 2015) for the software architecture of OAI. The eNB protocol stack is split in 3 different parts: the remote radio unit (RRU), which is an evolution of the classical remote radio head (RRH), the radio aggregation unit (RAU), which controls multiple RRUs potentially operating on different bands and with different coverages. As the name suggests this unit is responsible also for carrier aggregation and in the future also different radio access technologies. Last but not least the Radio Cloud Center (RCC) controls multiple RAUs. In the 3GPP 5G specifications the RCC is also called the central unit (CU) and RAU the distributed unit (DU).

The split between RRU and RAU is flexible and there are three possible options in OAI. The first two interfaces are similar to the ongoing standardization in IEEE “P1914.1 standard for packet-based fronthaul transport networks”. IF5 is similar to the classical BBU-RRH interface and transports baseband time domain IQ samples. IF4.5 corresponds to the split-point at the input (TX) and output (RX) of the OFDM symbol generator (i.e. frequency-domain signals) and transports resource elements in the usable channel band. Both interfaces also support optional A-law compression. Additionally to these two interfaces, OAI today also supports the small cells FAPI interface specifications P5 and P7 between the PHY and the MAC layer (Small Cell Forum, “FAPI and nFAPI specifications,” Small Cell Forum, Tech. Rep. 082.09.05, May 2017) that allows to offload the lower PHY functionality to the RRU.

The interface between RAU and RCC is currently under development and we are retro-fitting the current 5G-NR specifications for the F1 interface between CU and DU to 4G (3GPP, “F1 general aspects and principles,” 3GPP, Technical specification

38.470, Sep. 2017). Figure below summarizes the functional splits in OAI.

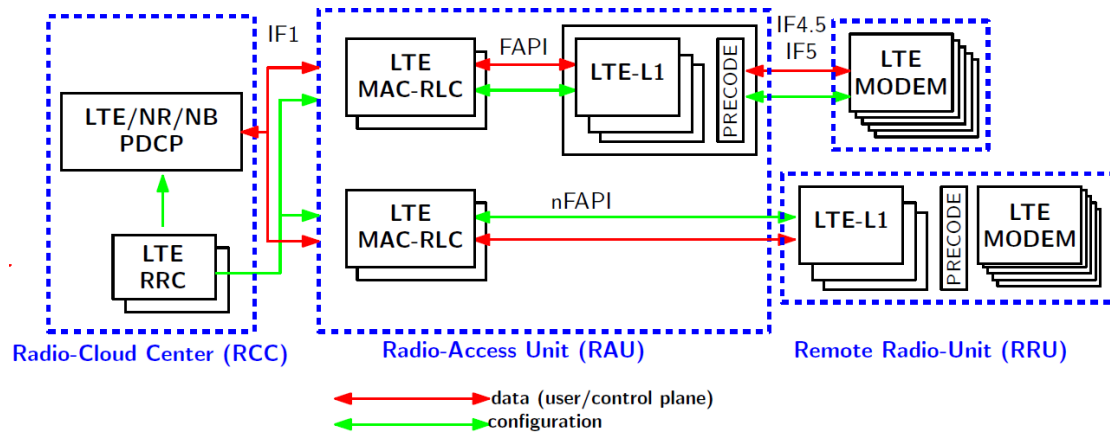

**Fig. 5.1.1. OAI functional splits**

### 5.1.3 C-RAN testbed

Eurecom is currently building and deploying a C-RAN network on its premises in Sophia-Antipolis. The platform will consist of a set of RRUs deployed on the ceilings of the corridors on levels -3 and -4 of the EURECOM building. The RRUs on each floor are connected by Gbit Ethernet to a switch which are in turn connected to a central server over optical 20Gbit Ethernet. An additional high power commercial remote radio head is connected to the C-RAN server through a CPRI gateway (see figure below).

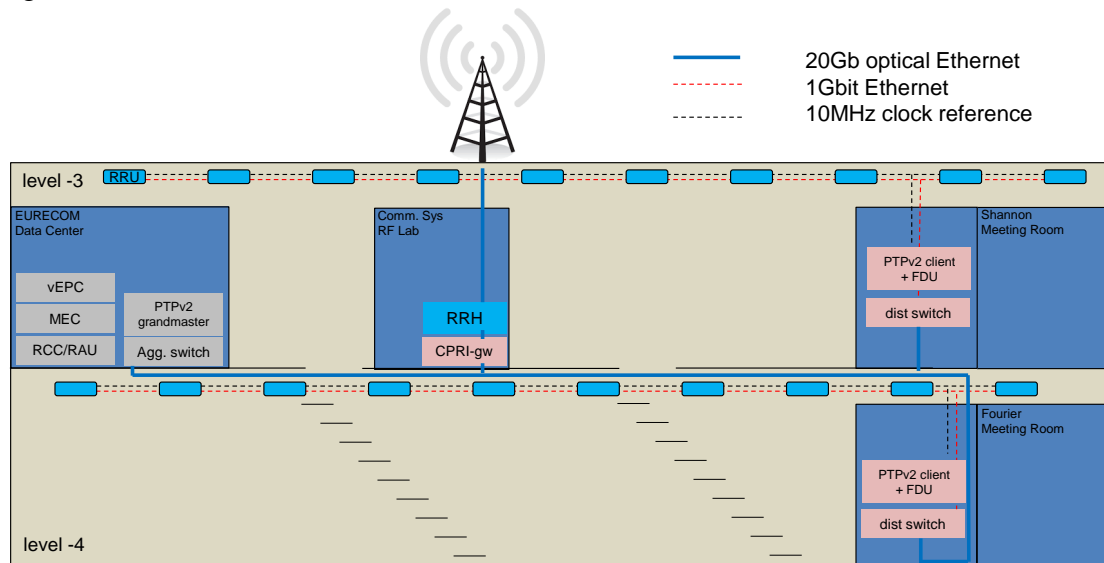

**Fig. 5.1.2. Floor plan of the Eurecom C-RAN deployment**

Frequency synchronization is provided by a clock distribution unit which provides a 10MHz reference signal on each floor. Timing synchronization is achieved by a special protocol in the RRUs that first listens to other RRUs within its range to derive the frame number and the start of the frame. In the future, the FDU on each floor can further be synchronized using the PTPv2 (IEEE 1588) protocol over optical fiber. For this a PTPv2 grandmaster clock will be placed in the server room and a PTPv2 client in the local server rooms.

The RRUs consist of an up-board from Intel, a B200 mini from Ettus research, a RF frontend designed by Eurecom and PoE module (see Figure 3). The RRUs will use



Band 38 (2.5 GHz) time-division duplex (TDD) for which EURECOM has been granted a license from the French regulatory body (ARCEP) for both indoor and short-range outdoor experiments (1km radio around our building).

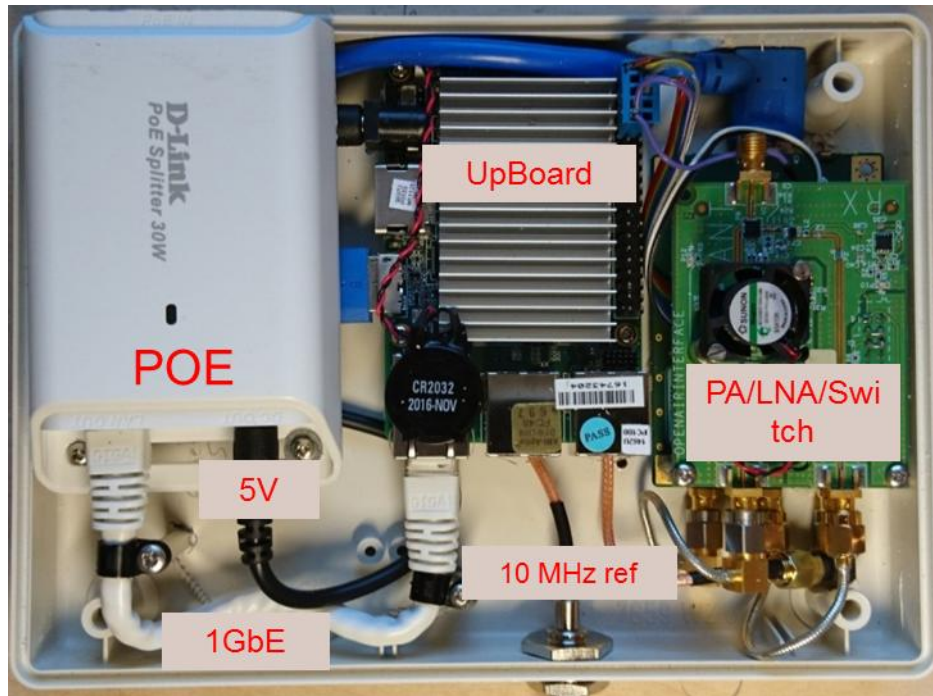

**Fig. 5.1.3. Remote Radio Unit (RRU) built from commodity hardware**

### 5.1.4 Conclusions

The OAI C-RAN testbed at Eurecom is accessible for all members of IRACON. At the moment remote access is under development, but interested people are invited to Eurecom to carry out their experiments in collaboration with the Eurecom team. Also see the website [www.openairinterface.org](http://www.openairinterface.org) for more details.

### 5.1.5 List of TDs

The following TDs have more information on the testbed.

- TD(16)02044,
- TD(17)03065,
- TD(17)04002.

## 6. Conclusions

To be written

