



HAL
open science

Experimental Investigations on Churning Power Losses Generated in a Planetary Gear Set

Jean-Baptiste Boni, Adrien Neurouth, Christophe Changenet, Fabrice Ville

► **To cite this version:**

Jean-Baptiste Boni, Adrien Neurouth, Christophe Changenet, Fabrice Ville. Experimental Investigations on Churning Power Losses Generated in a Planetary Gear Set. *Journal of Advanced Mechanical Design, Systems, and Manufacturing*, 2017, 00 (6), pp.JAMDSM0079-JAMDSM0079. 10.1299/jamdsm.2017jamdsm0079 . hal-01972480

HAL Id: hal-01972480

<https://hal.science/hal-01972480>

Submitted on 7 Jan 2019

HAL is a multi-disciplinary open access archive for the deposit and dissemination of scientific research documents, whether they are published or not. The documents may come from teaching and research institutions in France or abroad, or from public or private research centers.

L'archive ouverte pluridisciplinaire **HAL**, est destinée au dépôt et à la diffusion de documents scientifiques de niveau recherche, publiés ou non, émanant des établissements d'enseignement et de recherche français ou étrangers, des laboratoires publics ou privés.

Experimental Investigations on Churning Power Losses Generated in a Planetary Gear Set

Jean-Baptiste BONI*, Adrien NEUROUTH*, Christophe CHANGENET* and Fabrice VILLE**

*Univ. Lyon, ECAM Lyon, INSA-Lyon, LabECAM

40 montée St Barthélémy, 69005 Lyon, France

E-mail: christophe.changenet@ecam.fr

**Univ. Lyon, INSA-Lyon, LaMCoS, CNRS-UMR 5259,

20 avenue Albert Einstein, 69621 Villeurbanne, France

Received: 9th May 2017; Revised: 9th June 2017; Accepted: 3rd July 2017

Abstract

This study aims to experimentally investigate churning power losses generated by a planetary gear set which is splash lubricated. To this end, a specific test rig has been used to operate a planetary gear train under unloaded conditions in various configurations within a range of the planet-carrier rotational speed. Churning loss is isolated from the measured drag torque and the effects of several parameters (rotational speed, temperature, oil sump level, planet number...) on this source of dissipation are quantified. Beyond the influence of speed or oil level, it is concluded that the number of planets is of primary importance on churning power losses. Moreover, a first assumption is made concerning the oil sump behavior regarding the experiments: an oil ring is created explaining the evolution of the churning losses measured. In addition, this study compares the churning phenomenon occurring in cylindrical gear trains with the one observed during the experiments. It is shown that the approach used for conventional gear trains cannot be used for epicyclic ones: in planetary gear sets the centrifugal effects are predominant whereas the gravity forces have a larger influence on the free surface flows which occur in cylindrical gear sets.

Key words : Planetary gear set, Splash lubrication, Power losses, Churning losses, Drag losses

1. Introduction

Because of their compactness and axi-symmetric arrangement, planetary gearboxes are widely used in automotive and aerospace applications. In the general context of the reduction of energy consumption and polluting emissions, gearbox efficiency has become a major issue. The power losses in planetary gears can be divided into two parts: i) the load-dependent power losses associated with the friction between the gear teeth and the frictional moment in rolling element bearings and ii) the load-independent (or no-load) power losses such as those generated by gears and planet-carrier windage, oil trapping and/or churning, seals and the viscous forces in rolling element bearings.

Numerous studies on planetary gear sets focus on tooth friction losses in order to estimate an efficiency depending on the reaction (or fixed) member (sun gear, planet-carrier or ring-gear) from the individual internal and external mesh losses (Macmillan (1961), Radzimovsky (1959), Pennestri and Freudenstein (1993), Durand de Gevigney et al. (2013a)). As far as experimental studies are concerned, the power losses in planetary gears have generally been measured on back-to-back test rigs which make it possible to separate no-load losses from those under load. As an example, by using the back-to-back test rig at NASA Research Center, Anderson et al. (1984), Krantz (1990) or Rohn and Handschuh (1988) developed several empirical formulae in order to estimate planetary gear losses in aircraft and helicopter applications. All these studies clearly show the friction loss predominance as soon as planetary gears are significantly loaded. Of course, the power loss distribution depends also on rotational speed and numerous experiments have underlined that no-load power losses increase with speed. Two recent works have studied in detail no-load dependent power losses in a planetary gear train. On the one hand, Talbot et al. (2012) deduced from no-load tests that spin losses decrease when oil temperature increases and the number of planets is reduced. On the other hand, Durand de Gevigney et al. (2013b) have

developed a method to investigate the no-load power losses distribution in a specific planetary gear unit. This method is based on a thermal model which is used to analyze some experimental results. It is demonstrated that load independent power losses are mainly due to hydrodynamic losses generated in planet bearings and that gear windage effects are negligible. These two above-mentioned studies concern oil jet lubricated planetary gear sets, and, as a consequence, do not deal with churning losses associated with splash lubrication.

Churning refers to the drag associated with lubricant interaction for a component that is fully or partially immersed in an oil sump. The specific studies on churning losses generated by gears comprise those of Terekhov (1957) who developed empirical relations from experiments on spur gears rotating partially submerged in a fluid. Boness (1989) conducted some tests with discs of various dimensions and compared these results to experimental observations with a single gear. More recent studies presented several experiments to determine churning loss in single and meshed spur gear pairs (Höhn et al. (1996), Luke and Olver (1999), Changenet and Vexex (2007)). Changenet et al. (2011) have also proposed a method to extend these results to helical gears.

Applicability of these single gear or gear pair churning loss studies to planetary gear systems is limited because of the specific kinematics of planetary gears which may induce different fluid flows than the ones observed for cylindrical gears. In order to overcome this difficulty, the aim of this work is to experimentally investigate churning losses generated by a splash lubricated planetary gear set. To this end, a specific test rig has been used and is described in a first section of this paper. Then several experimental results are presented for different operating conditions (rotational speed, oil temperature and oil sump level). Because of the lack of studies concerning the churning torque generated by a planet-carrier, firstly a specific attention to this source of power losses is paid. Secondly, the complete gear train is studied and the influence of some mechanical components (e.g. the sun gear or the planets number) on churning losses is highlighted.

2. Test rig

The schematic representation of the test rig used in this study is presented in Fig. 1. An electric motor operates the planetary gear train via a belt. During this work, the speed was applied to the planet-carrier up to a maximum value of 1200rpm. The no-load power losses produced by the planetary gear set are determined from direct torque measurements by a strain gauged sensor. A pulse counter is integrated in the torque sensor so that it can be used for speed measurements too. Simultaneously to power loss measurements, several type K thermocouples (precision of $\pm 0.5\text{ C}^\circ$) that are located on various components (including the outer ring of roller bearings, ring-gear, oil sump...) are used to characterize the thermal behavior of the system during the tests. The precise localization of the temperature measurements are plotted with red circle in Fig. 2.

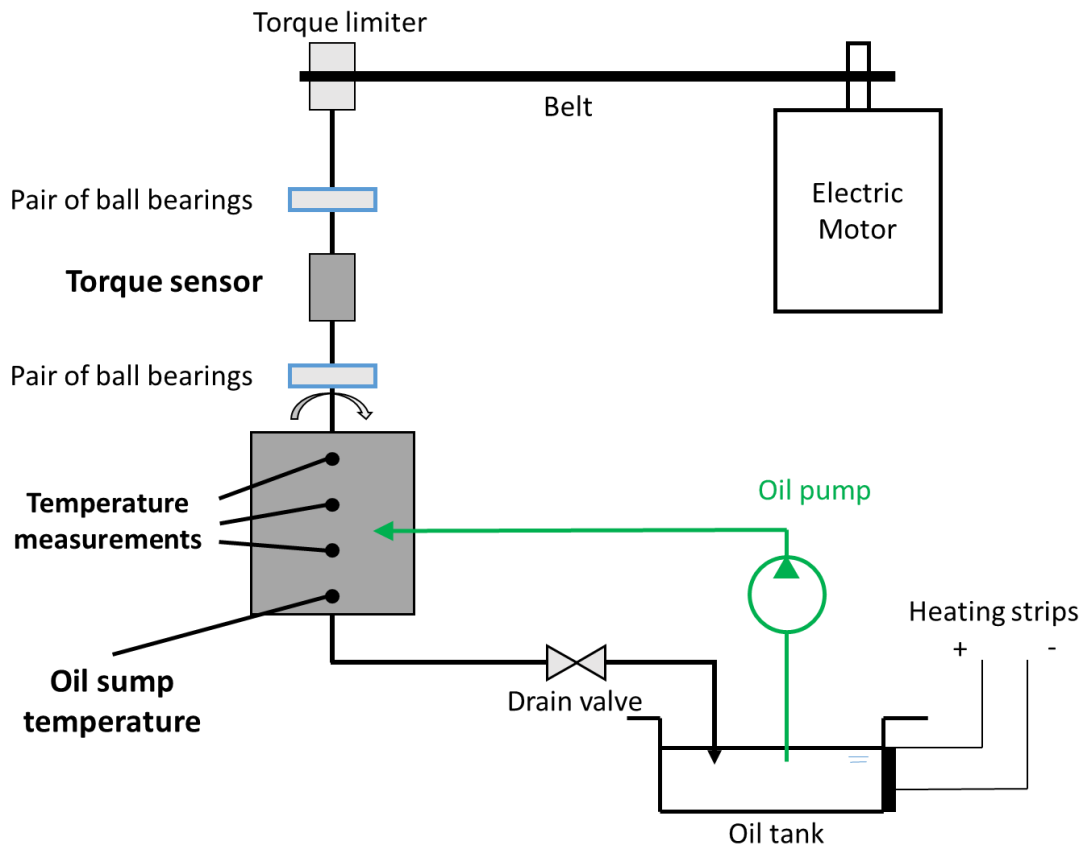

Fig. 1 Scheme of the test rig used to experiment on the churning losses occurring in planetary gears

The oil is pumped from a tank containing 30 liters of lubricant; several heating covers have been placed on the external faces of the tank in order to test a large range of lubricant viscosity. It can be noticed that the overall temperature of the gear unit can be increased by oil circulation: drain valve open. Originally, this test rig has been designed to study oil jet lubricated planetary gears. In order to use it with splash lubrication, oil injection pipes have been obstructed and the drain valve was added to the oil circuit. The geometrical characteristics of the epicyclic gear train under consideration are given in Table 1. It can be noticed that the planetary gear was designed in such a way that removing components is easy. Then, measurements with no sun gear and/or by removing some planets can be performed on the same system.

Table 1 Planetary gear set geometrical features

	Sun - gear	Planets	Ring-gear
Number of teeth	54	27	108
Module (mm)	1.4		
Tooth face width (mm)	37	30	32
Pressure angle (deg)	20		
Helix angle (deg)	0		
Number of planets	3		

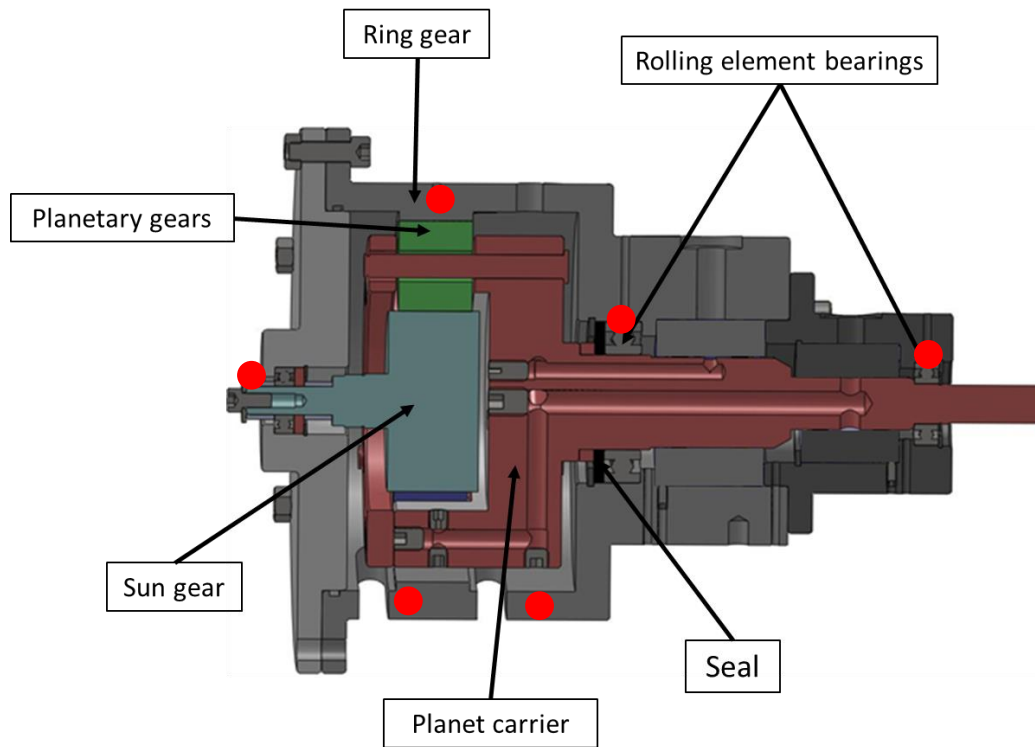

Fig. 2 Transmission section (temperature probes locations are plotted as red dots)

A schematic of the planetary gear train is given in Fig. 2. This figure shows that the shafts of this gear unit are mounted on rolling element bearings. A rotating seal is also used to prevent any oil leakage. Moreover, the planets are mounted on needle bearings. To isolate churning losses from the global torque measurement, the sources of dissipation associated with bearings and seal have to be characterized over a range of speeds and temperatures. To this end, some experiments have been conducted with no oil sump and the resisting torque was measured at different speeds and temperatures. For a given operating condition, this resisting torque is subtracted from global torque measurement to isolate the net power loss induced by churning.

The properties of the lubricant used in this study are given in Table 2.

Table 2 Oil properties used during the study

	40°C	100°C
Kinematic viscosity (cSt)	41.3	7.44
Density (kg/m ³)	837.8	804.5

The planetary gear set drag power losses were measured for a range of rotational speeds between 200 rpm and 1200 rpm. Moreover, the front lid of the gear unit housing is made of Plexiglas in order to check the oil sump static level. As it is shown in Fig. 3, this level is defined in comparison to the sun shaft position.

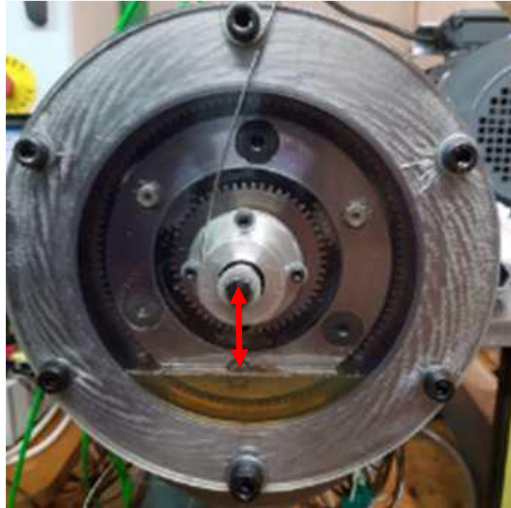

Fig. 3 Definition of oil sump static level (red arrow)

Tests performed for this study were conducted for different immersion levels (between -57mm and +45mm) and for different oil sump temperature: 30°C, 50°C and 70°C.

3. Analysis of oil distribution

As churning losses are related to lubricant flows around rotating components, this section aims to understand oil distribution for different geometrical configurations of the tested gear unit.

First of all, the oil flow generated by the sole planet-carrier which passes through the oil sump was observed. Figure 4 presents oil distribution around the planet-carrier at 400 rpm, for an oil temperature equal to 30°C and for the following static level: 0mm. Because of centrifugal effects, oil is ejected at the planet-carrier periphery and an oil ring is created.



Fig. 4 Oil flow around the planet-carrier. The oil ring can be observed on the periphery due to centrifugal effects

Similar results are obtained when the planets are mounted on the carrier: oil is always ejected and mixed with air inside the casing. It can be noticed that oil pocketing occurs between the planets and the ring gear. Fluid flows generated by this phenomenon can be seen in Fig. 5: oil jets from the sides of meshing zones are highlighted via the white circle plotted on the picture. This figure presents oil distribution around the assembly “planets + carrier” at 400 rpm, for an oil temperature equal to 30°C and for the following static level: -38mm.



Fig. 5 Oil distribution when planets are mounted on carrier. The oil pocketing is highlighted in the white circle

Same phenomena are visualized when the sun-gear is added to the system. Figure 6 shows a schematic drawing of the observed fluid disposition within the planetary gear set. As the speed increases, the oil sump tends to disappear and the lubricant is distributed more toward the outer circumference of the housing. Even for viscous fluid (oil temperature equal to 30°C), centrifugal forces are sufficient to eject the lubricant as soon as the rotational speed reaches a value near 200rpm. For low rotational speeds (smaller than 200rpm), the measured churning power loss never exceeds 20W. This value has been neglected and the assumption of an oil ring located at the outer circumference of the housing has been made for all experiments.

In the following sections of this paper, an equivalent fluid ring thickness is considered instead of the oil sump static level. To compute this thickness, an accurate oil volume calculation is required. For the test rig under consideration, the computation was performed by using CAD software.

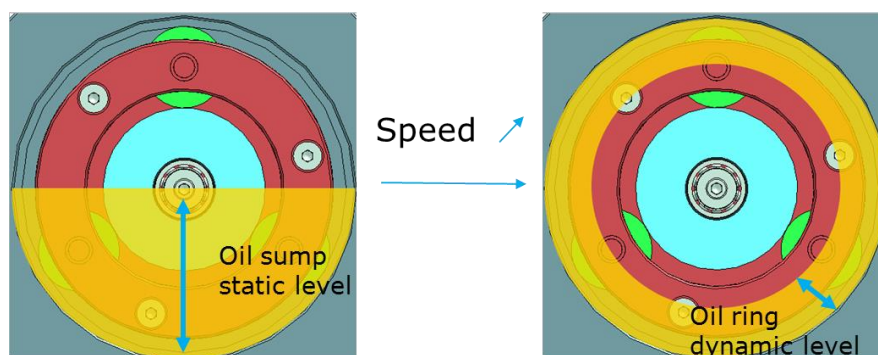

Fig. 6 Evolution of oil distribution when increasing the speed of the planet-carrier

4. Churning power losses

Figures 7 and 8 present churning power losses measured for different configurations: (i), the sole planet-carrier was used (Fig. 6); and (ii), three planets were mounted on the carrier (Fig. 7). These experiments have been conducted for different rotational speeds, for several temperatures and with an oil sump static level which reaches the sun gear axis. In this case, the dynamic oil level (i.e. oil ring thickness) is equal to 24mm. This level is not sufficient to immerse the sun

gear. It justifies that these experiments have been performed without this mechanical component.

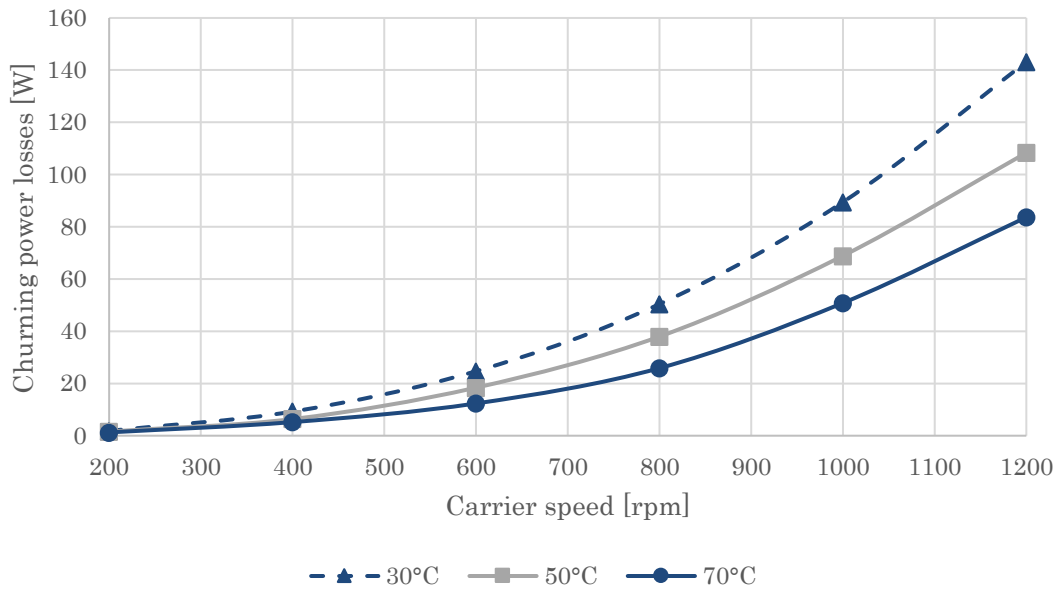

Fig. 7 Churning losses of the planet-carrier regarding the carrier speed and oil sump temperature for a dynamic oil level of 24mm

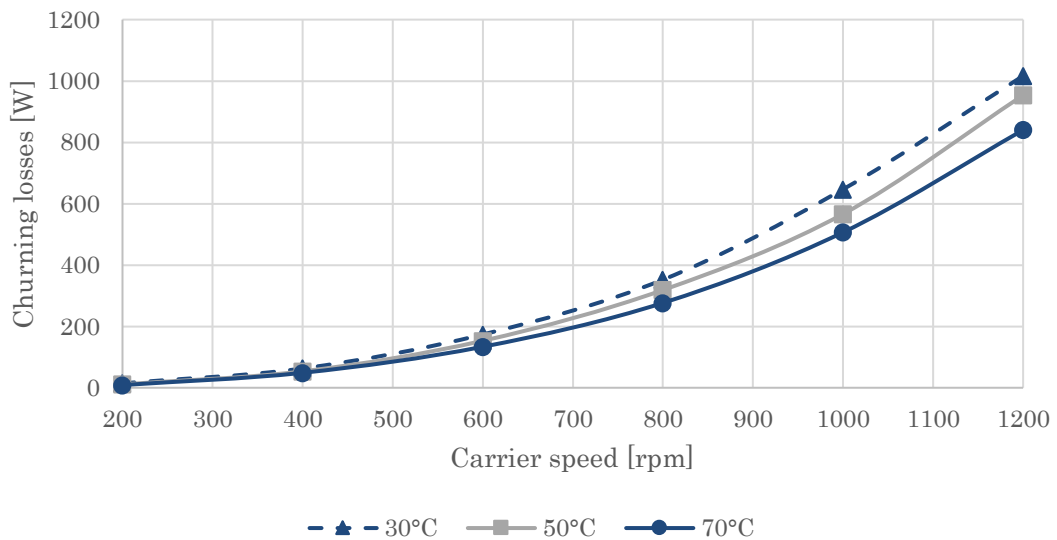

Fig. 8 Churning losses when three planets are mounted on the carrier regarding the carrier speed and oil sump temperature for a dynamic oil level of 24mm

Figure 7 clearly shows that the planet-carrier churning loss decreases with oil temperature or, in other words that the resisting torque increases with the lubricant kinematic viscosity (ν): the curves indicate that it is likely to be proportional to $\nu^{0.4}$. By adding planets to the carrier, power losses are much higher (Fig. 8): they are almost ten times bigger than the ones generated by the sole carrier. This result is in accordance with those obtained for injection lubrication. Indeed, some previous studies have already shown that the drag losses generated by the planet-carrier are small compared to the other sources of dissipation (Durand de Gevigney et al (2013a, 2013b), Kahraman et al (2014)). It can be also noticed that the influence of oil viscosity is less significant in the presence of planets: churning losses are almost proportional to $\nu^{0.2}$.

All the curves presented in Fig. 7 and 8 demonstrate that churning losses are strongly influenced by the rotational speed (Ω). They indicate that the total dissipation is likely to be proportional to $\Omega^{2.4}$.

To study the influence of planet number, some tests have been conducted by removing one or more planets and by using stationary cylinders (i.e. non-rotating mechanical components) instead of these gears. Figure 9 presents the results obtained at a lubricant temperature equal to 30°C, for different rotational speeds and with an oil sump static level which reaches the sun gear axis (equivalent fluid ring thickness of 24mm). When three smooth cylinders are used instead of three planets, it appears that churning losses are almost equal to the ones generated by the sole planet-carrier. By replacing a cylinder with a planet, churning resisting torque increases significantly: each planet generates almost one-third power loss which is added to the one associated with planet-carrier.

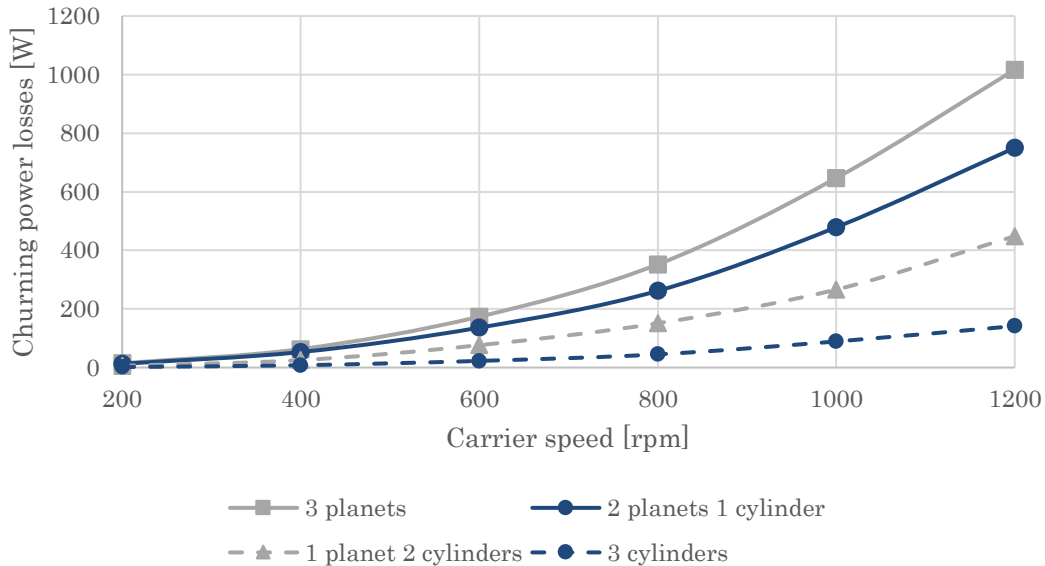

Fig. 9 Churning losses for different planets number regarding the carrier speed for a dynamic oil level of 24mm and an oil sump temperature of 30°C

Similar results were obtained with a lower immersion depth: an oil sump static level equal to -38mm, which corresponds to an equivalent fluid ring thickness of 6.5mm. As an example, Fig. 10 gives the measured power losses at a lubricant temperature of 30°C and for different rotational speeds. In this case the lubricant volume is not sufficient to fill the gap between the planet-carrier and the housing. As a result, a negligible loss is produced when three smooth cylinders are associated with the planet-carrier. Once again oil churning increases significantly when a planet is used instead of a stationary cylinder.

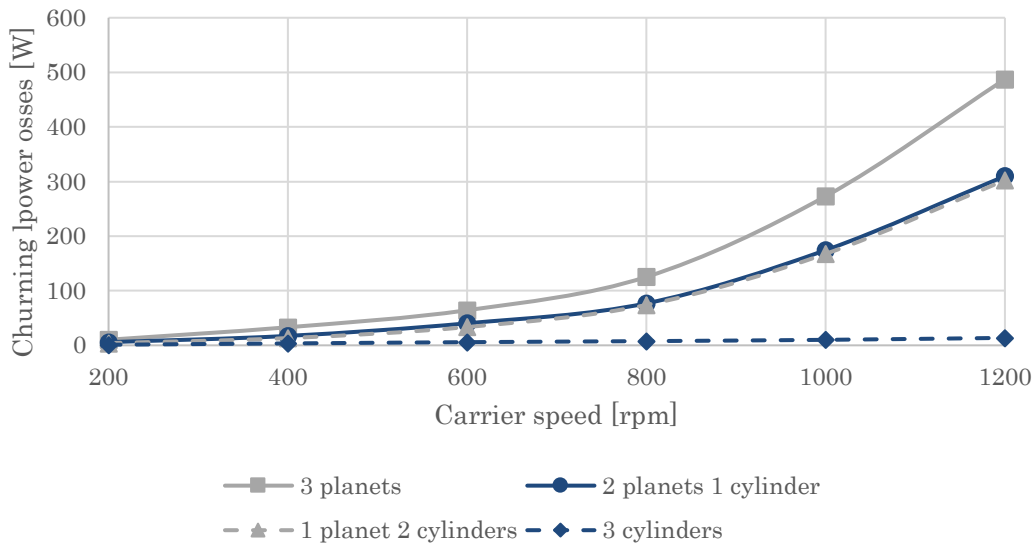

Fig. 10 Churning losses for different planets number regarding the carrier speed for a dynamic oil level of 6.5mm and an oil sump temperature of 30°C

A more systematic study of the evolution of churning losses as a function of the oil sump level was conducted. Figure 11 presents the experimental findings for a rotational speed equal to 800rpm and at 30°C. In this figure, power losses are plotted against the equivalent fluid ring thickness. Moreover, some tests were conducted with the complete planetary gear set and others by removing the sun-gear from this system. In Fig. 11, the dotted line represents the results with no sun-gear whereas the solid line accounts for churning losses generated by the complete planetary gear train.

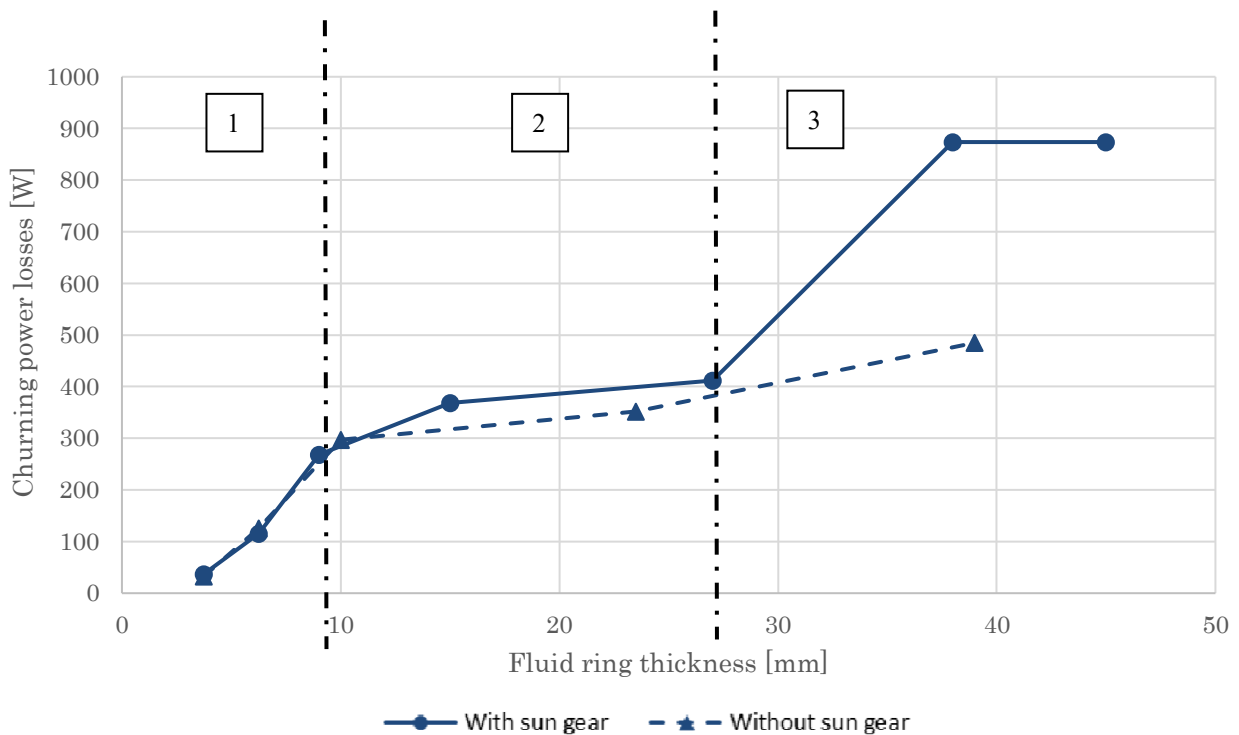

Fig. 11 Influence of oil level on churning losses for a rotational speed of the planet carrier of 800rpm and an oil sump temperature of 30°C

If one considers first the results when the sun gear is put together with the planets and the carrier, three different parts can be isolated from Fig. 11:

- In a first part, churning power losses increase quickly with immersion level;
- In a second part, this source of dissipation increases slowly with oil volume;
- In a third part, a sharp rise in churning power losses is once more observed, until a plateau is reached.

As far as churning losses without the sun gear are concerned, the sets of results are very similar to the ones obtained with the complete planetary gear set until the third part is reached. Then, churning losses generated by the planetary gear train without the sun gear are significantly lower and the difference between the two curves increases with the oil level.

5. Discussion

The above-mentioned results concerning the influence of oil level on churning losses underline that the sun gear has only an impact on this source of dissipation when the fluid ring thickness is large enough to immerse it. More generally, the geometrical characteristics of the planetary gear set under consideration can be used to understand the churning losses evolution presented in Fig. 11. In this figure, an oil thickness almost equal to 10mm shows the transition between the first and the second part of the curve. In the same way, a thickness almost equal to 27mm presents the change between the second and the third part. These values are reported on the drawing of the planetary gear train (see Fig. 12).

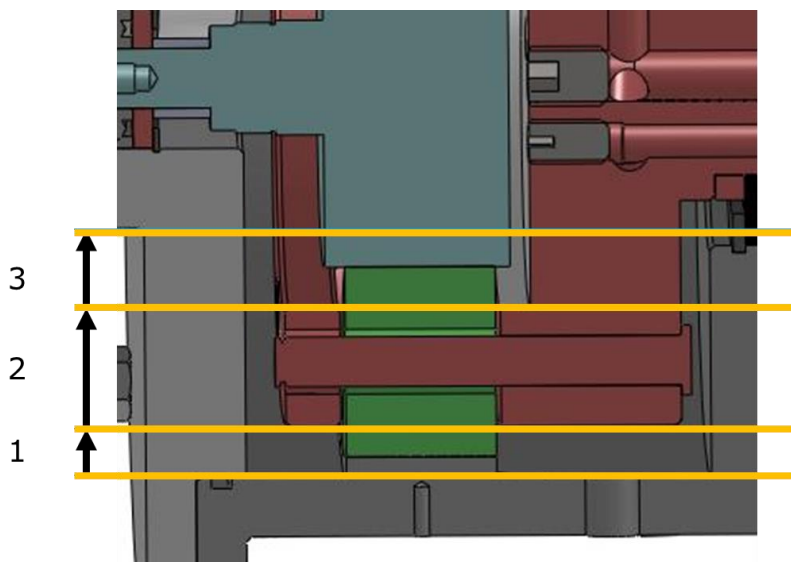

Fig. 12 Equivalence relation between oil level and planetary gear set geometry according to Fig. 11

According to Fig. 11, the following mechanical components have an influence on churning losses:

- In part 1, only planets are sources of dissipation.
- In part 2, the planet-carrier generates also oil churning. This source of dissipation has to be added to the previous one.

- In part 3, the planets are totally submerged in oil and the sun gear is a new source of power loss. As far as the sources of heat dissipation are concerned, they consist of (i) viscous drag losses associated with gears (planets and sun gear) and the planet-carrier, and (ii) pumping of an oil/air mixture from the spaces between meshing gear teeth. After all, the churning power losses of the planetary gear set (P_{ch}) can be expressed as follows by considering the different immersion levels:

- In part 1,

$$P_{ch} = n(P_{D,P} + P_{T,P-R}) \quad (1)$$

where n is the number of planets, $P_{D,P}$ represents drag power losses of planets and $P_{T,P-R}$ corresponds to the ones generated by fluid trapping in inter-tooth space between planets and ring gear.

- In part 2,

$$P_{ch} = n(P_{D,P} + P_{T,P-R}) + P_{D,C} \quad (2)$$

where $P_{D,C}$ represents drag power losses generated by the planet-carrier.

- In part 3,

$$P_{ch} = n(P_{D,P} + P_{T,P-R}) + P_{D,C} + P_{D,S} + n(P_{T,P-S}) \quad (3)$$

where n is the number of planets, $P_{D,S}$ represents drag power losses of sun gear and $P_{T,P-S}$ corresponds to the ones generated by fluid trapping in inter-tooth spaces between planets and sun gear.

As far as power losses estimation (for planetary gears, planet-carrier and sun gear) is concerned, one can consider that classical relationships, which have been developed to quantify churning losses of cylindrical gears, will not be appropriate to quantify these sources of dissipation. Indeed, for cylindrical gears, splash lubrication is characterized by a free surface flow which is mainly influenced by gravity. As an example, Kolekar (2014) and Changenet (2007), who have developed empirical relationships to quantify this source of dissipation, have rely the drag torque to a Froude Number to quantify the ratio of the inertial to gravity forces in the flow. This dimensionless number depends on the gear rotational speed and then determines the churning losses evolution with speed. The laws developed by Changenet (2007) and Kolekar (2014) indicate that power loss is approximately proportional to $\Omega^{1.5}$. As presented previously, in case of planetary gears, the total dissipation is likely to be proportional to $\Omega^{2.4}$. This behavior difference can be explained by the oil flow: as stated before, an oil ring is created in the planetary gear set. The gravity forces have a smaller influence on this oil ring and the influence of the Froude number is less significant. As a conclusion, specific studies have now to be conducted to establish analytical relationships to quantify churning losses of a planetary gear set.

6. Conclusion

A specific test rig has been exploited to measure oil churning losses in a splash lubricated planetary gear set. Tests were performed for different operating conditions: rotational speed, oil sump level and temperature. An increase of the lubricant temperature was shown to produce a moderate decrease in churning loss, whereas it is strongly influenced by the rotational speed. Moreover, as the speed increases, the oil sump tends to disappear and the lubricant is distributed more toward the outer circumference of the housing. Then the oil sump level influence has to be interpreted according to this fluid distribution. The planetary gear set under consideration was designed in such a way that removing components is easy. Then experiments with no sun gear and/or by removing some planets have been performed during this study. These tests have demonstrated that churning losses of a planetary gear train can be represented by a set of components consisting of viscous drag losses associated with gears (planets and sun gear) and the planet-carrier, and of oil trapping in inter-tooth spaces between planets and ring gear or planets and sun gear. The power losses caused by planet-carrier drag forces do not appear to be major contributors to the churning loss, whereas the number of planets is of primary importance.

Acknowledgements

The authors would like to thank Volvo trucks for funding this research. They would also like to express their gratitude to Emmanuel Defrance and Jean-Pierre Battistelli for valuable discussions and support during this study.

References

- Anderson, N.E., Loewenthal, S.H., Black, J.D., An analytical method to predict efficiency of aircraft gearboxes, NASA TM-83716, USAAVSCOM TR 84-C-8, (1984).
- Boness, R.J., Churning losses of discs and gears running partially submerged in oil, Proceedings of ASME International Power Transmission Gearing Conference 1989, (1989) 355-359.
- Changenet, C., Velex, P., A model for the prediction of churning losses in geared transmissions – preliminary results, J. Mechanical Design, 129, 1 (2007) 128-133.
- Changenet, C., Leprince, G., Ville, F., Velex, P., A note on flow regimes and churning loss modeling, J. Mechanical Design, 133, 12 (2011) 5p.
- Durand de Gevigney, J., Ville, F., Changenet, C., Velex, P., Tooth friction losses in internal gears: analytical formulation and applications to planetary gears, Proc. IMechE Part J: J. Engineering Tribology, 225, 5 (2013a) 476-485.
- Durand de Gevigney, J., Changenet, C., Ville, F., Velex, P., Becquerelle, S., Experimental investigation on no-load dependent power losses in a planetary gear set, Proceedings of International Conference on Gears 2013, (2013b) 1101-1112.
- Höhn, B.R., Michaelis, K., Völlmer, T., Thermal rating of gear drives: balance between power loss and heat dissipation, American Gear Manufacturers Association Document, 96FTM8, (1996).
- Kahraman, A., Hilty, D.R., Singh, A., An experimental study of spin power losses of planetary gear sets, Proceedings of International Gear Conference 2014, (2014)
- Kolekar, A., Anant, S., et al., Windage and Churning Effects in Dipped Lubrication, Journal of Tribology 136.2: 021801, (2014)
- Krantz, T.L., Experimental and analytical evaluation of efficiency of helicopter planetary stage, NASA TP-3063, AVSCOM TR 90-C-001, (1990).
- Luke, P., Olver, A., A study of churning losses in dip-lubricated spur gears, Proc. IMechE Part G: J. Aerospace Engineering, 213, (1999) 337-346.
- Macmillan, R.H., Power flow and loss in differential mechanisms, J. Mechanical Engineering Science, 3, 1 (1961) 37-41.
- Pennestri, E., Freudenstein, F., The mechanical efficiency of epicyclic gear trains, J. Mechanical Design, 115, 3 (1993) 645-651.
- Radzimovsky, E.I., How to find efficiency, speed, and power in planetary gear drives, Machine Design, 11, (1959) 144-153.
- Terekhov, A.S., Hydraulic losses in gearboxes with oil immersion, Vestnik Mashinostroeniya, 55, 5 (1975) 13-17.
- Velex, P., Becquerelle, S., Analysis of no-load dependent power losses in a planetary gear train by using thermal network method, Proceedings of International Gear Conference 2014, (2014), 615-624.