



HAL
open science

About the gauge conditions arising in Finite Element magnetostatic problems

Emmanuel Creusé, Patrick Dular, Serge Nicaise

► **To cite this version:**

Emmanuel Creusé, Patrick Dular, Serge Nicaise. About the gauge conditions arising in Finite Element magnetostatic problems. *Computers & Mathematics with Applications*, 2019, 77 (6), pp.1563-1582. 10.1016/j.camwa.2018.06.030 . hal-01955649

HAL Id: hal-01955649

<https://hal.science/hal-01955649v1>

Submitted on 14 Dec 2018

HAL is a multi-disciplinary open access archive for the deposit and dissemination of scientific research documents, whether they are published or not. The documents may come from teaching and research institutions in France or abroad, or from public or private research centers.

L'archive ouverte pluridisciplinaire **HAL**, est destinée au dépôt et à la diffusion de documents scientifiques de niveau recherche, publiés ou non, émanant des établissements d'enseignement et de recherche français ou étrangers, des laboratoires publics ou privés.

About the gauge conditions arising in Finite Element magnetostatic problems

Emmanuel Creusé^{*†}
Patrick Dular^{†‡}
Serge Nicaise[§]

January 30, 2018

Abstract

In this paper, we deal with some magnetostatic models considered in vector potential formulations and solved by a Finite Element solver. In order to ensure the uniqueness of the solution, a gauge condition has to be imposed, and several possibilities occur. Moreover, the source term has to be correctly defined to ensure a physically admissible solution. We show the equivalence between some of these choices for several kinds of boundary conditions. Moreover, we highlight their characteristic behaviors on some numerical benchmarks to illustrate our theoretical results.

Key Words: Maxwell equations, potential formulations, gauge conditions, finite element method.

AMS (MOS) subject classification 35Q61; 65N30.

1 Introduction

Two important aspects of the magnetic vector potential (finite element) formulations, for both magnetostatics and magnetodynamics, concern the source current densities \mathbf{j}_s in stranded conductors and the gauge conditions making the magnetic vector potential \mathbf{A} unique [10, 13]. The ways to define the related constraints are of importance

^{*}Laboratoire de Mathématiques Paul Painlevé UMR 8524. Université Lille 1, Cité Scientifique, 59655 Villeneuve d'Ascq Cedex, France. emmanuel.creuse@math.univ-lille1.fr.

[†]INRIA Lille Nord Europe, EPI RAPSODI. Parc scientifique de la Haute Borne 40, avenue Halley - Bât A - Park Plaza, 59650 Villeneuve d'Ascq, France.

[‡]Unit of Applied and Computational Electromagnetics, Université de Liège, Belgium. patrick.dular@ulg.ac.be

[§]Univ. Valenciennes, EA 4015 - LAMAV - Laboratoire de Mathématiques et leurs Applications de Valenciennes, FR CNRS 2956, F-59313 Valenciennes, France. serge.nicaise@univ-valenciennes.fr.

for a correctly posed problem, from its continuous and discrete formulations, up to its robust and accurate numerical resolution. A source \mathbf{j}_s has to fulfill adequate discrete zero divergence properties. A gauge condition on \mathbf{A} also requires adequate properties to allow its practical discrete FE implementation. Such constraints can be defined in strong or weak ways. Standard gauge conditions are either the Coulomb gauge or the tree-cotree gauge (with curl-conform edge FEs for \mathbf{A}). Similarly, the zero divergence of a source \mathbf{j}_s can be either strongly satisfied via a curl-conform source field (an electric vector potential) as commonly done [7, 8], or weakly satisfied via a weak formulation, which appears as an interesting natural alternative. In this paper, we analyse from a mathematical point of view these different strategies, and prove their equivalence in the continuous as well as in the discrete frameworks. In a first attempt, we focus on the magnetostatic case and on the so-called "A-formulation".

From now on, we consider an open simply connected bounded and polyhedral domain $\Omega \subset \mathbb{R}^3$ with a Lipschitz boundary $\partial\Omega = \Gamma = \Gamma_h \cup \Gamma_b$ such that Γ_b is connected (see Figure 1). We denote $\Omega_s = \text{supp } \mathbf{j}_s$, where \mathbf{j}_s is the source part of the current

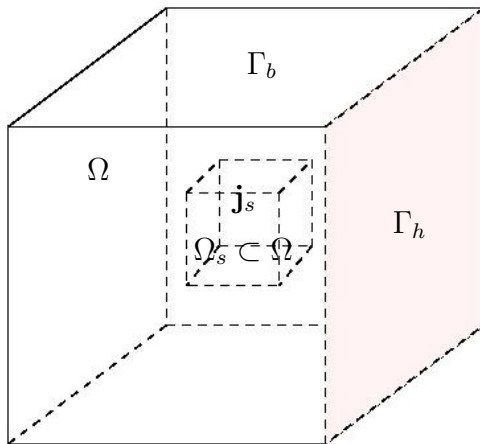

Figure 1: The domain Ω and $\Omega_s \subset \Omega$. Here, $\Gamma = \Gamma_h \cup \Gamma_b$ with Γ_h the right side of the cube and Γ_b the union of the other sides.

density. The equations and material relations of this problem are then given by:

$$\text{curl } \mathbf{H} = \mathbf{j}_s, \text{ in } \Omega, \quad (1)$$

$$\text{div } \mathbf{B} = 0 \text{ in } \Omega, \quad (2)$$

$$\mathbf{B} = \mu \mathbf{H}, \text{ in } \Omega, \quad (3)$$

with boundary conditions:

$$\mathbf{n} \times \mathbf{H} = 0, \text{ on } \Gamma_h, \quad (4)$$

$$\mathbf{B} \cdot \mathbf{n} = 0, \text{ on } \Gamma_b. \quad (5)$$

Here \mathbf{H} is the magnetic field and \mathbf{B} stands for the magnetic flux density. As usual, $\mu \in L^\infty(\Omega)$ is the magnetic permeability of the material that is uniformly bounded from below (i.e., there exists a positive real number μ_0 such that $\mu > \mu_0$ in Ω). The boundary condition on Γ_b corresponds to the truncation of the full space, while the boundary condition on Γ_h follows from symmetry considerations. From (2), a magnetic vector potential \mathbf{A} can be defined such that

$$\mathbf{B} = \text{curl } \mathbf{A} \text{ in } \Omega. \quad (6)$$

In terms of \mathbf{A} and v , if Γ_b is simply connected, the boundary condition (5) is equivalent to

$$\mathbf{n} \times \mathbf{A} = \mathbf{n} \times \nabla \varphi \text{ on } \Gamma_b, \quad (7)$$

with some $\varphi \in H^1(\Omega)$. Hence by subtracting $\nabla \varphi$ to \mathbf{A} , namely setting $\mathbf{A}' = \mathbf{A} - \nabla \varphi$, we get another vector potential of \mathbf{B} satisfying

$$\mathbf{n} \times \mathbf{A}' = 0, \text{ on } \Gamma_b.$$

To ensure the uniqueness of \mathbf{A} , it is necessary to impose a gauge condition. The most popular one is $\text{div } \mathbf{A} = 0$ (called the Coulomb gauge). If Γ_b is not simply connected, then (5) and (7) are no more equivalent with $\varphi \in H^1(\Omega)$, but we shall see below how to replace this condition (7).

Remark 1.1. *This magnetostatic problem could be easily generalized considering a conductor part $\Omega_c \subset \Omega$ in which some eddy currents would be generated. In that case, the Faraday law linking the time derivative of the magnetic induction \mathbf{B} to the curl of the electric field \mathbf{E} would have to be added, generating a current density $\mathbf{J} = \sigma \mathbf{E}$ in Ω_c with σ being the electrical conductivity of the material. Such configurations will be addressed in the future.*

2 The case Γ_b simply connected

In this section, we consider the case where Γ_b is simply connected (see e.g. Fig 1).

2.1 Continuous weak formulation

We first start with the weak formulation of our magnetostatic problem. Indeed, multiplying the Ampère equation (1) by a test function \mathbf{A}' , integrating in Ω and using Green's formula we get :

$$\int_{\Omega} \mathbf{H} \cdot \text{curl } \mathbf{A}' \, dx - \int_{\Omega_s} \mathbf{j}_s \cdot \mathbf{A}' \, dx + \int_{\Gamma} (\mathbf{n} \times \mathbf{H}) \cdot \mathbf{A}' \, d\sigma = 0.$$

Using the boundary condition (4) and the relations (3) and (6), we obtain

$$\int_{\Omega} \mu^{-1} \text{curl } \mathbf{A} \cdot \text{curl } \mathbf{A}' \, dx - \int_{\Omega_s} \mathbf{j}_s \cdot \mathbf{A}' \, dx + \int_{\Gamma_b} (\mathbf{n} \times \mathbf{H}) \cdot \mathbf{A}' \, d\sigma = 0.$$

Since we can chose test-functions such that $\mathbf{n} \times \mathbf{A}' = 0$ on Γ_b , we arrive at :

$$\int_{\Omega} \mu^{-1} \operatorname{curl} \mathbf{A} \cdot \operatorname{curl} \mathbf{A}' dx - \int_{\Omega_s} \mathbf{j}_s \cdot \mathbf{A}' dx = 0. \quad (8)$$

This problem ([16, Lemma 3.30] or [14, Lemma 2]) has a unique solution in the space

$$X_0(\Omega) = \left\{ \mathbf{A} \in H(\operatorname{curl}, \Omega); \mathbf{n} \times \mathbf{A} = 0 \text{ on } \Gamma_b \text{ and } (\mathbf{A}, \nabla \xi)_{\Omega} = 0, \forall \xi \in H_{\Gamma_b}^1(\Omega) \right\},$$

where

$$H_{\Gamma_b}^1(\Omega) = \{v \in H^1(\Omega); v = 0 \text{ on } \Gamma_b\},$$

provided \mathbf{j}_s is divergence free in the sense that

$$(\mathbf{j}_s, \nabla \xi)_{\Omega} = 0, \forall \xi \in H_{\Gamma_b}^1(\Omega), \quad (9)$$

but uniqueness is not guaranteed.

The condition

$$(\mathbf{A}, \nabla \xi)_{\Omega} = 0, \forall \xi \in H_{\Gamma_b}^1(\Omega) \quad (10)$$

corresponds to the Coulomb gauge condition and allows to show that the bilinear form

$$\int_{\Omega} \mu^{-1} \operatorname{curl} \mathbf{A} \cdot \operatorname{curl} \mathbf{A}' dx$$

is coercive in $X_0(\Omega)$ [11]. Indeed (10) is a weak form of

$$\operatorname{div} \mathbf{A} = 0 \text{ in } \Omega \text{ and } \mathbf{A} \cdot \mathbf{n} = 0 \text{ on } \Gamma_h.$$

Note that problem (8) remains well-posed in

$$X(\Omega) = \left\{ \mathbf{A} \in H(\operatorname{curl}, \Omega); \mathbf{n} \times \mathbf{A} = 0 \text{ on } \Gamma_b \right\},$$

but uniqueness is not guaranteed.

2.2 Discrete weak formulations

We consider now a conforming mesh \mathcal{T}_h of Ω made of tetrahedra. The extension of the above results to other elements, like quad or hexahedra, is straightforward. The vector field \mathbf{A} is approximated by first order edge elements. Thus we consider the Nédélec finite element

$$\mathcal{N}\mathcal{D}_1(T) = \left\{ \mathbf{F}_h : T \longrightarrow \mathbb{R}^3, \mathbf{x} \longrightarrow \mathbf{a} + \mathbf{b} \times \mathbf{x}, \mathbf{a}, \mathbf{b} \in \mathbb{R}^3 \right\},$$

and the approximation space of the continuous space $X(\Omega)$:

$$X_h(\Omega) = \left\{ \mathbf{A}_h \in H(\operatorname{curl}, \Omega); \mathbf{n} \times \mathbf{A}_h = 0 \text{ on } \Gamma_b; \mathbf{A}_{h|T} \in \mathcal{N}\mathcal{D}_1(T), \forall T \in \mathcal{T}_h \right\}.$$

At this point, we introduce the discrete problem (compare with (8)): find $\mathbf{A}_h \in X_h(\Omega)$ solution of

$$\int_{\Omega} \mu^{-1} \operatorname{curl} \mathbf{A}_h \cdot \operatorname{curl} \mathbf{A}'_h \, dx - \int_{\Omega_{s,h}} \mathbf{j}_{s,h} \cdot \mathbf{A}'_h \, dx = 0, \forall \mathbf{A}'_h \in X_h(\Omega), \quad (11)$$

where $\mathbf{j}_{s,h}$ is an approximation of \mathbf{j}_s and $\Omega_{s,h}$ is a polyhedral approximation of Ω_s made of elements of the triangulation \mathcal{T}_h . Problem (11) has a (non-unique) solution provided $\mathbf{j}_{s,h}$ is discrete divergence free, namely if it satisfies (14) below. The uniqueness is guaranteed if a discrete gauge condition is imposed on \mathbf{A}_h . In this section we analyze two standard gauge conditions and comment how to solve (11) without imposing any gauge.

2.2.1 Coulomb gauge

The first natural gauge is to introduce the space

$$X_{0,h}(\Omega) = \left\{ \mathbf{A}_h \in X_h(\Omega); (\mathbf{A}_h, \nabla \xi_h) = 0, \forall \xi_h \in H_{\Gamma_b,h}^1(\Omega) \right\},$$

where

$$H_{\Gamma_b,h}^1(\Omega) = \left\{ v_h \in H_{\Gamma_b}^1(\Omega); v_{h|T} \in \mathbb{P}_1(T), \forall T \in \mathcal{T}_h \right\}.$$

Hence we look for a solution $\mathbf{A}_h \in X_{0,h}(\Omega)$ to

$$\int_{\Omega} \mu^{-1} \operatorname{curl} \mathbf{A}_h \cdot \operatorname{curl} \mathbf{A}'_h \, dx - \int_{\Omega_{s,h}} \mathbf{j}_{s,h} \cdot \mathbf{A}'_h \, dx = 0, \forall \mathbf{A}'_h \in X_{0,h}(\Omega). \quad (12)$$

This problem has a unique solution as the next Lemma shows.

Lemma 2.1. *Problem (12) has a unique solution $\mathbf{A}_h \in X_{0,h}(\Omega)$.*

Proof. As problem (12) corresponds to a square linear system, injectivity is equivalent to surjectivity. Let us then show its injectivity. Hence let $\mathbf{A}_h \in X_{0,h}(\Omega)$ be such that

$$\operatorname{curl} \mathbf{A}_h = 0.$$

Then as Ω is simply connected, by de Rham complex diagram (2.5.58) of [2], there exists $w_h \in H_h^1(\Omega) = \left\{ v_h \in H^1(\Omega); v_{h|T} \in \mathbb{P}_1(T) \forall T \in \mathcal{T}_h \right\}$ such that

$$\mathbf{A}_h = \nabla w_h.$$

Since $\mathbf{A}_h \times \mathbf{n} = 0$ on Γ_b , there exists $c \in \mathbb{R}$ such that $w_h = c$ on Γ_b and consequently $w_h - c$ belongs to $H_{\Gamma_b,h}^1(\Omega)$ and

$$\mathbf{A}_h = \nabla(w_h - c).$$

Since \mathbf{A}_h is in $X_{0,h}(\Omega)$, we deduce that $\mathbf{A}_h = \mathbf{0}$. ■

The calculation of a basis of $X_{0,h}(\Omega)$ requires a Gram-Schmidt procedure and is rather technical. Consequently, to solve problem (12) we propose to introduce a Lagrange multiplier [15]. Namely we introduce an unknown $\xi_h \in H_{\Gamma_b,h}^1(\Omega)$ and look for the problem :

$$\begin{cases} (\mu^{-1}\text{curl } \mathbf{A}_h, \text{curl } \mathbf{A}'_h) - (\mathbf{j}_{s,h}, \mathbf{A}'_h)_{\Omega_{s,h}} - (\nabla \xi_h, \mathbf{A}'_h) = 0, \forall \mathbf{A}'_h \in X_h(\Omega), \\ (\mathbf{A}_h, \nabla \xi'_h) = 0 \forall \xi'_h \in H_{\Gamma_b,h}^1(\Omega). \end{cases} \quad (13)$$

We first see that the discrete inf/sup condition between the spaces $X_h(\Omega)$ and $H_{\Gamma_b,h}^1(\Omega)$ is fulfilled. Indeed,

$$\inf_{\xi_h \in H_{\Gamma_b,h}^1(\Omega)} \sup_{\mathbf{A}_h \in X_h(\Omega)} \frac{(\nabla \xi_h, \mathbf{A}_h)}{\|\mathbf{A}_h\|_{X_h(\Omega)} \|\xi_h\|_{1,\Omega}} \geq \inf_{\xi_h \in H_{\Gamma_b,h}^1(\Omega)} \frac{(\nabla \xi_h, \nabla \xi_h)}{\|\nabla \xi_h\|_{X_h(\Omega)} \|\xi_h\|_{1,\Omega}} = 1,$$

since by definition,

$$\|\mathbf{A}_h\|_{X_h(\Omega)}^2 = \|\text{curl } \mathbf{A}_h\|^2 + \|\mathbf{A}_h\|^2.$$

Moreover, setting $a(\mathbf{A}_h, \mathbf{A}'_h) = (\mu^{-1}\text{curl } \mathbf{A}_h, \text{curl } \mathbf{A}'_h)$ and $b(\mathbf{A}_h, \xi'_h) = (\mathbf{A}_h, \nabla \xi'_h)$, the bilinear form a is coersive on the kernel of b . Consequently, by Lemma 4.1 of [9], problem (13) has a unique solution.

Note that problem (13) is equivalent to problem (12) if $\mathbf{j}_{s,h}$ is discrete divergence free, namely if it satisfies

$$(\mathbf{j}_{s,h}, \nabla w_h) = 0, \forall w_h \in H_{\Gamma_b,h}^1(\Omega). \quad (14)$$

2.2.2 Co-tree gauging

In order to derive the co-tree gauging technique, we first have to consider a tree τ of the triangulation, defined as a set of connected edges of the mesh \mathcal{T}_h passing by all the nodes of \mathcal{T}_h without generating any closed loop (see an example in Figure 2 on a 2-D case). Let us denote by $\tau' = \mathcal{E}_h \setminus \tau$ its associated co-tree, and let $X_{h,\tau}(\Omega)$ be the subspace of $X_h(\Omega)$ spanned by the edge basis element of τ' , namely

$$X_{h,\tau}(\Omega) = \text{Span}\{\mathbf{s}_e : e \in \tau' \setminus \bar{\Gamma}_b\},$$

where \mathbf{s}_e denotes the basis function of $X_h(\Omega)$ associated with the edge e .

The co-tree gauging method consists in looking for $\mathbf{A}_{h,\tau} \in X_{h,\tau}(\Omega)$ solution of

$$\int_{\Omega} \mu^{-1} \text{curl } \mathbf{A}_{h,\tau} \cdot \text{curl } \mathbf{A}'_h \, dx - \int_{\Omega_s} \mathbf{j}_{s,h} \cdot \mathbf{A}'_h \, dx = 0, \forall \mathbf{A}'_h \in X_{h,\tau}(\Omega). \quad (15)$$

This problem has a unique solution since the curl operator

$$\text{curl} : X_{h,\tau}(\Omega) \rightarrow \mathbb{P}_0(\Omega) : \mathbf{A}_h \rightarrow \text{curl } \mathbf{A}_h,$$

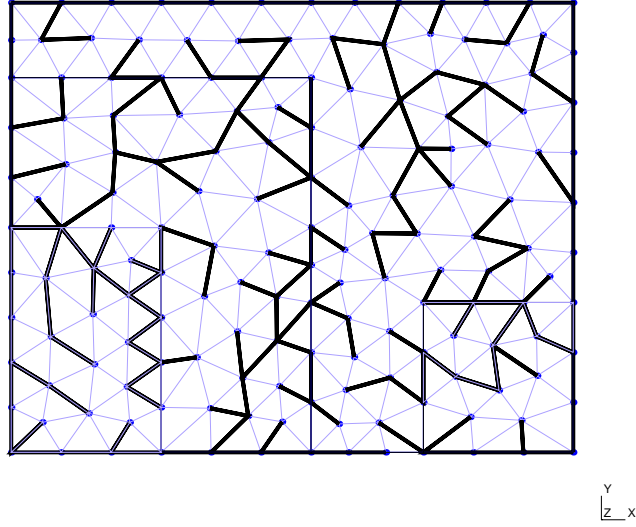

Figure 2: Tree τ (in bold) and associated co-tree τ' (other edges) in 2-D.

is injective [12]. But a natural question concerns the uniqueness of the curl, namely if we take two different trees τ and τ^* , do we have

$$\text{curl } \mathbf{A}_{h,\tau} = \text{curl } \mathbf{A}_{h,\tau^*}?$$

To answer to this question, we prove a Helmholtz type decomposition.

Theorem 2.2. *The next Helmholtz type decomposition holds: for all tree τ and all $\mathbf{A}_h \in X_h(\Omega)$, it holds*

$$\mathbf{A}_h = \mathbf{A}'_h + \nabla w_h, \quad (16)$$

with $\mathbf{A}'_h \in X_{h,\tau}(\Omega)$ and $w_h \in H^1_{\Gamma_b,h}(\Omega)$.

Proof. It suffices to show that for any $e \in \tau$ such that $e \subset \Omega \cup \Gamma_h$, one has

$$\mathbf{s}_e = \mathbf{A}'_h + \nabla w_h, \quad (17)$$

with $w_h \in H^1_{\Gamma_b,h}(\Omega)$ and $\mathbf{A}'_h \in X_{h,\tau}(\Omega)$.

To prove this last identity we classify the edges of the tree τ by generations in the following way. Fix one edge e of τ such that e has a common extremity with an edge of τ' , and call this edge the root of the tree (and the first generation). Then all edges of τ that have an extremity in common with e form the second generation. We continue iteratively, namely for $i \geq 2$, the edges of the $(i+1)^{th}$ generation are those whose have a common extremity with an edge of the i^{th} generation.

Now fix an edge e of the last generation, then by construction it has an extremity v such that all other edges f of \mathcal{E}_h are in τ' . By [3, Proposition 5.4], we have

$$\sum_{f \in \mathcal{E}_h: v \in f} p(f, v) \mathbf{s}_f = \nabla \lambda_v, \quad (18)$$

where λ_v corresponds to the \mathbf{P}_1 -Lagrange finite element basis function associated with the node v and $p(f, v)$ is equal to 1 if t_f is pointing in the direction of v and is equal to -1 else. Hence we deduce that

$$\mathbf{s}_e = -p(e, v)^{-1} \sum_{f \in \tau': v \in f} p(f, v) \mathbf{s}_f + p(e, v)^{-1} \nabla \lambda_v, \quad (19)$$

which proves (17) for the edge of the last generation.

For an edge e of the last but one generation, denote by e_i , $i = 1, \dots, I$ the edges of the last generation of τ that have a common vertex v with e and by e'_i , $i = 1, \dots, I'$ the edge of τ' that also have v as common vertex with e . Then using (18) at this vertices v , we get

$$p(e, v) \mathbf{s}_e = - \sum_{i=1}^I p(e_i, v) \mathbf{s}_{e_i} - \sum_{i=1}^{I'} p(e'_i, v) \mathbf{s}_{e'_i} + \nabla \lambda_v,$$

and using (19) to the edges e_i , we arrive at (17) for the edge of the last but one generation.

By iteration from one generation to the previous one, we obtain (17) for all edges of τ . ■

Corollary 2.1. *Let τ and τ^* be two trees, and assume that $\mathbf{j}_{s,h}$ satisfies (14), then*

$$\operatorname{curl} \mathbf{A}_{h,\tau} = \operatorname{curl} \mathbf{A}_{h,\tau^*}. \quad (20)$$

Proof. By (15), (16) and the assumption on $\mathbf{j}_{s,h}$, we have

$$\int_{\Omega} \mu^{-1} \operatorname{curl} \mathbf{A}_{h,\tau} \cdot \operatorname{curl} \mathbf{A}'_h \, dx - \int_{\Omega_s} \mathbf{j}_{s,h} \cdot \mathbf{A}'_h \, dx = 0, \forall \mathbf{A}'_h \in X_h(\Omega).$$

Therefore, it holds

$$\int_{\Omega} \mu^{-1} \operatorname{curl} (\mathbf{A}_{h,\tau} - \mathbf{A}_{h,\tau^*}) \cdot \operatorname{curl} \mathbf{A}'_h \, dx = 0, \forall \mathbf{A}'_h \in X_h(\Omega),$$

which implies (20). ■

In the same manner, we can prove the next result:

Corollary 2.2. *Let τ be a tree, let $\mathbf{A}_h \in X_{0,h}(\Omega)$ be the unique solution of (12) and assume that $\mathbf{j}_{s,h}$ satisfies (14), then*

$$\operatorname{curl} \mathbf{A}_{h,\tau} = \operatorname{curl} \mathbf{A}_h.$$

2.2.3 No gauging

Without gauging, problem (11) has a (non-unique) solution if $\mathbf{j}_{s,h}$ satisfies (14). It has been noticed in [13] that if a conjugate gradient method is used to find a solution of this problem by starting with an initial value equal to zero, then each iterate \mathbf{A}_k satisfies

$$(\mathbf{A}_k, \nabla \xi_h) = 0 \quad \forall \xi_h \in H_{\Gamma_b,h}^1(\Omega),$$

and therefore the sequence \mathbf{A}_k converges to the unique solution $\mathbf{A}_h \in X_{0,h}(\Omega)$ of (12).

3 The case Γ_b non simply connected

Now, we consider the case where Γ_b is no more simply connected (see e.g. Fig 3). We recall that Ω is a polyhedron, having in mind to use some results of [4, 5] in the following, for which this assumption has to be done.

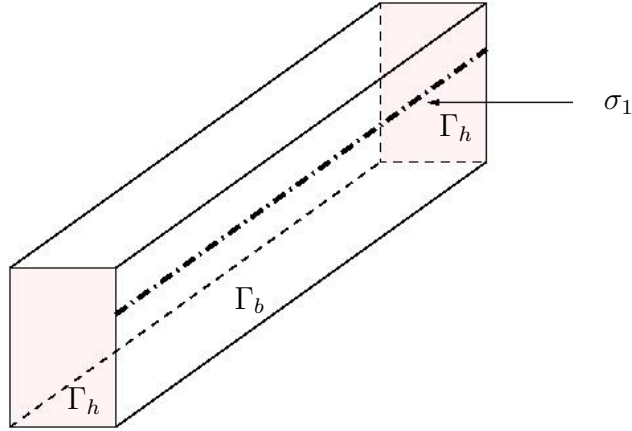

Figure 3: The domain Ω and the cut σ_1 . Here, $\Gamma = \Gamma_h \cup \Gamma_b$ with Γ_h the two colored sides of the hexahedra and Γ_b the union of the other sides.

3.1 Continuous weak formulation

In that case, we need to introduce some “cuts” σ_j , $j = 1, \dots, J$ contained in Γ_b such that

- each σ_j is a Lipschitz open curve,
- the extremities of σ_j are contained in the boundary of Γ_b ,
- $\bar{\sigma}_j \cap \bar{\sigma}_k$ is empty if $j \neq k$,
- The set

$$\Gamma_b^\circ = \Gamma_b \setminus \bigcup_{j=1}^J \sigma_j$$

becomes simply connected.

In that situation, we introduce the space (compare with Notation 3.9 of [1])

$$\Theta = \{r \in H^{\frac{1}{2}}(\Gamma_b^\circ) : [r]_j \stackrel{\frac{1}{2}}{=} \text{constant}, 1 \leq j \leq J\},$$

where $[r]_j \stackrel{\frac{1}{2}}{=} \text{constant}$ means that there exists a constant $c_j \in \mathbb{C}$ such that

$$\int_{\Gamma_j^+} \int_{\Gamma_j^-} \frac{|r_{j+}(x) - r_{j-}(y) - c_j|^2}{|x - y|^3} d\sigma(x) d\sigma(y) < \infty,$$

where Γ_j^+ and Γ_j^- are two different subsets of Γ_b° having σ_j included in its boundary and $r_{j\pm}$ is the restriction of r on Γ_j^\pm . Note that Θ is larger than $H^{\frac{1}{2}}(\Gamma_b)$ but its complement is finite-dimensional as the next Lemma shows. Indeed for all $j = 1, \dots, J$, let us fix $\varphi_j \in H^1(\Gamma_b^\circ)$ such that

$$[\varphi_j]_j = 1 \text{ and } [\varphi_j]_k = 0, \forall k \neq j,$$

where here $[\varphi_j]_k$ means the jump in the sense of trace.

Lemma 3.1. *We have*

$$\Theta = H^{\frac{1}{2}}(\Gamma_b) \oplus \text{Span} \{\varphi_j\}_{j=1}^J.$$

Proof. Let $r \in \Theta$, then for all $j = 1, \dots, J$, there exists a constant $c_j \in \mathbb{C}$ such that

$$[r]_j \stackrel{\frac{1}{2}}{=} c_j.$$

Therefore the function

$$\tilde{r} = r - \sum_{j=1}^J c_j \varphi_j,$$

belongs to $H^{\frac{1}{2}}(\Gamma_b)$ since it is in $H^{\frac{1}{2}}(\Gamma_b^\circ)$ and $[\tilde{r}]_j \stackrel{\frac{1}{2}}{=} 0, \forall j = 1, \dots, J$. ■

With the notations from [4, 5], we recall that from [5, Rk 6.7], the mapping

$$\pi_\tau^b : H(\text{curl}, \Omega) \rightarrow H_{\perp, 00}^{-\frac{1}{2}}(\text{curl}_{\Gamma_b}, \Gamma_b) : \mathbf{A} \rightarrow \mathbf{n} \times (\mathbf{A} \times \mathbf{n}),$$

is linear continuous and surjective. According to this surjectivity property, for any $j = 1, \dots, J$, there exists $\psi_j \in H(\text{curl}, \Omega)$ such that

$$\mathbf{n} \times (\psi_j \times \mathbf{n}) = \nabla_{\Gamma_b} \varphi_j \text{ on } \Gamma_b. \quad (21)$$

These functions are linearly independent and are such that

$$\text{curl } \psi_j \neq 0.$$

Indeed if $\text{curl } \psi_j$ would be zero, then there would exist a function $\chi_j \in H^1(\Omega)$ such that

$$\psi_j = \nabla \chi_j,$$

and hence

$$\nabla_{\Gamma_b} \chi_j = \nabla_{\Gamma_b} \varphi_j.$$

This is impossible because we would get

$$\chi_j - \varphi_j = c \text{ on } \Gamma_b^\circ,$$

for some $c \in \mathbb{C}$, and therefore

$$[\varphi_j]_j \stackrel{\frac{1}{2}}{=} 0,$$

which is impossible. The linearly independence of the ψ_j is proved similarly. Without loss of generality we can assume that ψ_j satisfies the Coulomb gauge (10). Indeed if it is not the case, we can consider the unique solution $\xi_j \in H_{\Gamma_b}^1(\Omega)$ of

$$(\nabla \xi_j, \nabla \xi) = (\psi_j, \nabla \xi), \forall \xi \in H_{\Gamma_b}^1(\Omega).$$

And the new functions $\tilde{\psi}_j = \psi_j - \nabla \xi_j$ keep the same properties than before and satisfies (10). Note finally that

$$\text{curl } \psi_j \cdot \mathbf{n} = \text{curl}_{\Gamma_b}(\mathbf{n} \times (\psi_j \times \mathbf{n})) = \text{curl}_{\Gamma_b} \nabla_{\Gamma_b} \varphi_j = 0 \text{ on } \Gamma_b.$$

We now characterize the kernel of curl_{Γ_b} in $H_{\perp,00}^{-\frac{1}{2}}(\text{curl}_{\Gamma_b}, \Gamma_b)$.

Lemma 3.2. *It holds*

$$\ker \text{curl}_{\Gamma_b} = \nabla_{\Gamma_b} \Theta.$$

In other words, $\mathbf{B} \in H_{\perp,00}^{-\frac{1}{2}}(\text{curl}_{\Gamma_b}, \Gamma_b)$ is such that $\text{curl}_{\Gamma_b} \mathbf{B} = 0$ if and only if there exists $r \in \Theta$ such that

$$\mathbf{B} = \nabla_{\Gamma_b} r.$$

Proof. The inclusion $\nabla_{\Gamma_b} \Theta \subset \ker \text{curl}_{\Gamma_b}$ being direct, it suffices to prove the converse inclusion. Let us then fix $\mathbf{B} \in H_{\perp,00}^{-\frac{1}{2}}(\text{curl}_{\Gamma_b}, \Gamma_b)$ such that $\text{curl}_{\Gamma_b} \mathbf{B} = 0$. Denote by Γ_ℓ , $\ell = 1, 2$ two simply connected subdomains of Γ_b° with a Lipschitz boundary containing all the cuts and such that $\Gamma_b^\circ = \Gamma_1 \cup \Gamma_2$. Then applying Remark 6.5 of [5], there exists $r_\ell \in H^{\frac{1}{2}}(\Gamma_\ell)$, $\ell = 1, 2$ such that

$$\mathbf{B} = \nabla_\tau r_\ell \text{ on } \Gamma_\ell.$$

Hence

$$\nabla_\tau(r_1 - r_2) = 0 \text{ on } \Gamma_1 \cap \Gamma_2,$$

or equivalently there exists a constant c such that

$$r_1 - r_2 = c \text{ on } \Gamma_1 \cap \Gamma_2.$$

Then we define r as follows:

$$r = \begin{cases} r_1 & \text{on } \Gamma_1, \\ r_2 + c & \text{on } \Gamma_2 \setminus \Gamma_1. \end{cases}$$

Hence r belongs to $H^{\frac{1}{2}}(\Gamma_b^\circ)$.

As the tangential component of \mathbf{B} is formally continuous through a cut σ_j , we should deduce that r belongs to Θ . To prove it correctly, let us fix one cut σ_j and consider $\tilde{\Gamma}_j$ a small neighborhood of σ_j such that $\tilde{\Gamma}_j$ is simply connected with a Lipschitz boundary. The again applying Remark 6.5 of [5], there exists $\tilde{r}_j \in H^{\frac{1}{2}}(\tilde{\Gamma}_j)$ such that

$$\mathbf{B} = \nabla_\tau \tilde{r}_j \text{ on } \tilde{\Gamma}_j.$$

Consequently

$$\nabla_\tau(\tilde{r}_j - r) = 0 \text{ on } \tilde{\Gamma}_j \cap \Gamma_1,$$

as well as

$$\nabla_\tau(\tilde{r}_j - r) = 0 \text{ on } \tilde{\Gamma}_j \cap \Gamma_2.$$

This implies that there exist two constants c_{j+} and c_{j-} such that

$$\tilde{r}_j - r = c_{j-} \text{ on } \tilde{\Gamma}_j \cap \Gamma_1,$$

as well as

$$\tilde{r}_j - r = c_{j+} \text{ on } \tilde{\Gamma}_j \cap \Gamma_2.$$

As $[\tilde{r}_j]_j \stackrel{\frac{1}{2}}{=} 0$, we deduce that

$$[r]_j \stackrel{\frac{1}{2}}{=} c_{j-} - c_{j+}.$$

This proves that r belongs to Θ . ■

With these results, we are able to state a sort of Helmholtz decomposition.

Lemma 3.3. *Let $\mathbf{A} \in H(\text{curl}, \Omega)$ be such that*

$$\text{curl } \mathbf{A} \cdot \mathbf{n} = 0 \text{ on } \Gamma_b.$$

Then there exist $\varphi \in H^1(\Omega)$, $\mathbf{C} \in X_0(\Omega)$ and coefficients $\alpha_j, j = 1, \dots, J$ such that

$$\mathbf{A} = \nabla\varphi + \mathbf{C} + \sum_{j=1}^J \alpha_j \psi_j.$$

Proof. By Lemma 3.2, we have

$$\mathbf{n} \times (\mathbf{A} \times \mathbf{n}) = \nabla_{\Gamma_b} r, \text{ on } \Gamma_b,$$

with $r \in \Theta$. According to Lemma 3.1, this means that there exist $\varphi \in H^1(\Omega)$ and some constants $\alpha_j, j = 1, \dots, J$ such that

$$\mathbf{n} \times (\mathbf{A} \times \mathbf{n}) = \nabla_{\Gamma_b} \varphi + \sum_{j=1}^J \alpha_j \nabla_{\Gamma_b} \varphi_j.$$

By the definition of ψ_j , we get

$$\mathbf{n} \times (\mathbf{A} \times \mathbf{n}) = \mathbf{n} \times (\nabla \varphi \times \mathbf{n}) + \sum_{j=1}^J \alpha_j (\mathbf{n} \times (\psi_j \times \mathbf{n})).$$

Therefore the vector field

$$\mathbf{C} = \mathbf{A} - \nabla \varphi - \sum_{j=1}^J \alpha_j \psi_j$$

belongs to $H(\text{curl}, \Omega)$ and satisfies $\mathbf{n} \times \mathbf{C} = 0$ on Γ_b . Again by eventually subtracting to \mathbf{C} a gradient of a function in $H_{\Gamma_b}^1(\Omega)$, we can assume that $\mathbf{C} \in X_0(\Omega)$. ■

At this stage we can come back to the vector potential \mathbf{A} of \mathbf{B} in (6) that, due to (5), satisfies the condition of the previous Lemma. Since the gradient plays now role on $\text{curl } \mathbf{A}$, we are then reduced to look for \mathbf{A} in the space

$$V := X_0(\Omega) \oplus \text{Span} \{\psi_j\}_{j=1}^J.$$

The space V is clearly a Hilbert space equipped with the norm

$$\|\mathbf{A}\|_V^2 = \|\mathbf{A}_0\|_{H(\text{curl}, \Omega)}^2 + \sum_{j=1}^J |\alpha_j|^2,$$

when $\mathbf{A} = \mathbf{A}_0 + \sum_{j=1}^J \alpha_j \psi_j$, with $\mathbf{A}_0 \in X_0(\Omega)$ and $(\alpha_j)_{j=1}^J \in \mathbb{C}^J$. Note that, by a simple application of the triangular inequality, the norm

$$\|\mathbf{A}_0\|_{\Omega} + \sum_{j=1}^J |\alpha_j| + \|\text{curl } \mathbf{A}\|_{\Omega}$$

is equivalent to the norm $\|\cdot\|_V$.

Note further that any $\mathbf{A} \in V$ satisfies

$$\text{curl } \mathbf{A} \cdot \mathbf{n} = 0 \text{ on } \Gamma_b.$$

In summary, in the case of a non simply connected Γ_b , problem (8) becomes: Find $\mathbf{A} \in V$ such that

$$\int_{\Omega} \mu^{-1} \text{curl } \mathbf{A} \cdot \text{curl } \mathbf{A}' dx = \int_{\Omega_s} \mathbf{j}_s \cdot \mathbf{A}' dx + \int_{\Gamma_b} (\mathbf{n} \times \mathbf{H}) \cdot \mathbf{A}' d\sigma, \forall \mathbf{A}' \in V, \quad (22)$$

where \mathbf{H} is a given vector field on Γ_b such that $\operatorname{div}_{\Gamma_b}(\mathbf{n} \times \mathbf{H}) = 0$ on Γ_b and $\mathbf{n} \times \mathbf{H} = 0$ on $\partial\Gamma_b$. Note that the required property on $\mathbf{n} \times \mathbf{H}$ has a physical meaning since in practice $\mathbf{H} = \mu^{-1} \operatorname{curl} \mathbf{A}$ and if μ is constant near Γ_b , then (see [4, p. 23])

$$\operatorname{div}_{\Gamma_b}(\mathbf{n} \times \mathbf{H}) = \mu^{-1} \operatorname{curl} \mathbf{A} \cdot \mathbf{n} = 0 \text{ on } \Gamma_b.$$

Secondly the boundary condition on $\partial\Gamma_b$ is in accordance with the boundary condition (4). Note that \mathbf{j}_s is still a current density, while the term $\int_{\Gamma_b} (\mathbf{n} \times \mathbf{H}) \cdot \mathbf{A}' d\sigma$ corresponds to the magnetomotive force. Indeed using the splitting

$$\mathbf{A}' = A'_0 + \sum_{j=1}^J \beta'_j \psi_j, \quad (23)$$

with $A'_0 \in X_0(\Omega)$ and some constants β'_j , we have

$$\int_{\Gamma_b} (\mathbf{n} \times \mathbf{H}) \cdot \mathbf{A}' d\sigma = \sum_{j=1}^J \beta'_j \int_{\Gamma_b} (\mathbf{n} \times \mathbf{H}) \cdot \psi_j d\sigma.$$

Hence the identity (21) allows to write

$$\int_{\Gamma_b} (\mathbf{n} \times \mathbf{H}) \cdot \mathbf{A}' d\sigma = \sum_{j=1}^J \beta'_j \int_{\Gamma_b} (\mathbf{n} \times \mathbf{H}) \cdot \nabla_{\Gamma_b} \varphi_j d\sigma.$$

Now by Green's formula in Γ_b° , the property of φ_j through the cuts, and the properties on \mathbf{H} mentioned below, we see that

$$\int_{\Gamma_b} (\mathbf{n} \times \mathbf{H}) \cdot \nabla_{\Gamma_b} \varphi_j d\sigma = \int_{\sigma_j} \mathbf{H} \cdot d\ell,$$

which is a given constant δ_j (that is independent of the choice of σ_j). In summary problem (22) is equivalent to

$$\int_{\Omega} \mu^{-1} \operatorname{curl} \mathbf{A} \cdot \operatorname{curl} \mathbf{A}' dx = \int_{\Omega_s} \mathbf{j}_s \cdot \mathbf{A}' dx + \sum_{j=1}^J \delta_j \beta'_j, \quad (24)$$

for all $\mathbf{A}' \in V$ splitted in the form (23).

Let us notice that in this equivalent formulation, we do not need to know the pointwise value of \mathbf{H} on the whole of Γ_b , but we only need its circulation on each cut.

As usual, the well-posedness of this problem is based on the coercivity of the bilinear form a defined by

$$a(\mathbf{A}, \mathbf{A}') := \int_{\Omega} \mu^{-1} \operatorname{curl} \mathbf{A} \cdot \operatorname{curl} \mathbf{A}' dx, \forall \mathbf{A}, \mathbf{A}' \in V.$$

Lemma 3.4. *The bilinear form a is continuous and coercive on V .*

Proof. The continuity of a being trivial, let us show that it is coercive, namely that there exists $\alpha > 0$ such that

$$a(\mathbf{A}, \mathbf{A}) \geq \alpha \|\mathbf{A}\|_V^2, \forall \mathbf{A} \in V.$$

This estimate clearly holds if and only if

$$a(\mathbf{A}, \mathbf{A}) \geq \beta (\|\mathbf{A}_0\|_\Omega + \sum_{j=1}^J |\alpha_j|)^2, \forall \mathbf{A} \in V,$$

for some $\beta > 0$. We prove that this last estimate holds by contradiction. Indeed assume that it is wrong, this means that there exists a sequence of $\mathbf{A}^{(n)} \in V, n \in \mathbb{N}^*$ such that

$$\|\mathbf{A}_0^{(n)}\|_\Omega + \sum_{j=1}^J |\alpha_j^{(n)}| = 1, \quad (25)$$

$$\|\operatorname{curl} \mathbf{A}^{(n)}\|_\Omega = \frac{1}{n}, \forall n \in \mathbb{N}^*, \quad (26)$$

when $\mathbf{A}^{(n)} = \mathbf{A}_0^{(n)} + \sum_{j=1}^J \alpha_j^{(n)} \psi_j$, with $\mathbf{A}_0^{(n)} \in X_0(\Omega)$ and $\alpha_j^{(n)} \in \mathbb{C}$.

As

$$\|\operatorname{curl} \mathbf{A}_0^{(n)}\|_\Omega \leq \|\operatorname{curl} \mathbf{A}^{(n)}\|_\Omega + \sum_{j=1}^J |\alpha_j^{(n)}| \|\operatorname{curl} \psi_j\|_\Omega \lesssim 1,$$

we deduce that the sequence $(\mathbf{A}_0^{(n)})_{n \in \mathbb{N}^*}$ is bounded in $X_0(\Omega)$. As $X_0(\Omega)$ is compactly embedded into $L^2(\Omega)^3$ [14, Lemma 2], we can extract a subsequence, still denoted by $(\mathbf{A}_0^{(n)})_{n \in \mathbb{N}^*}$, such that

$$\mathbf{A}_0^{(n)} \rightarrow \mathbf{A}_0 \text{ in } L^2(\Omega)^3, \text{ as } n \rightarrow \infty,$$

for some $\mathbf{A}_0 \in X_0(\Omega)$. Further as \mathbb{C} is finite dimensional, by (25), there exists a subsequence, still denoted by $(\alpha_j^{(n)})_{n \in \mathbb{N}^*}$, such that

$$\alpha_j^{(n)} \rightarrow \alpha_j \text{ in } \mathbb{C}, \text{ as } n \rightarrow \infty,$$

for any $j = 1, \dots, J$. These two properties imply that the sequence $(\mathbf{A}^{(n)})_{n \in \mathbb{N}^*}$ is convergent in $L^2(\Omega)^3$, namely

$$\mathbf{A}^{(n)} \rightarrow \mathbf{A} = \mathbf{A}_0 + \sum_{j=1}^J \alpha_j \psi_j \text{ in } L^2(\Omega)^3, \text{ as } n \rightarrow \infty. \quad (27)$$

This property and (25) imply that

$$\|\mathbf{A}_0\|_\Omega + \sum_{j=1}^J |\alpha_j| = 1. \quad (28)$$

The properties (26) and (27) imply that the sequence $(\mathbf{A}^{(n)})_{n \in \mathbb{N}^*}$ is a Cauchy sequence in $H(\text{curl}, \Omega)$ and consequently

$$\text{curl } \mathbf{A}^{(n)} \rightarrow \text{curl } \mathbf{A} \text{ in } L^2(\Omega)^3, \text{ as } n \rightarrow \infty.$$

Again by (26), we deduce that

$$\text{curl } \mathbf{A} = 0. \quad (29)$$

Similarly as $\mathbf{A}^{(n)}$ satisfies (10), its limit \mathbf{A} also satisfies (10).

Now by (29), and the fact that Ω is simply connected, there exists $\varphi \in H^1(\Omega)$ such that

$$\mathbf{A} = \nabla \varphi.$$

This implies that

$$\mathbf{n} \times \nabla \varphi = \mathbf{n} \times \mathbf{A} = \sum_{j=1}^J \alpha_j \mathbf{n} \times \psi_j \text{ on } \Gamma_b,$$

and by (21), we deduce that

$$\nabla_{\Gamma_b} \varphi = \sum_{j=1}^J \alpha_j \nabla_{\Gamma_b} \varphi_j \text{ on } \Gamma_b.$$

Consequently there exists $c \in \mathbb{C}$ such that

$$\varphi = \sum_{j=1}^J \alpha_j \varphi_j + c \text{ on } \Gamma_b^\circ.$$

As $[\varphi]_j = 0$, we deduce that $\alpha_j = 0$ for all $j = 1, \dots, J$. Therefore $\mathbf{A} = \mathbf{A}_0$ belongs to $X_0(\Omega)$ and therefore as Γ_b is connected,

$$\varphi = c \text{ on } \Gamma_b.$$

Then $\tilde{\varphi} = \varphi - c$ belongs to $H_{\Gamma_b}^1(\Omega)$ and $\mathbf{A} = \nabla \tilde{\varphi}$ satisfies (10), which implies that $\tilde{\varphi} = 0$, whence $\mathbf{A} = 0$. This contradicts (28). ■

Corollary 3.5. *The space V is compactly embedded into $L^2(\Omega)^3$.*

According to Lax-Milgram Lemma, we deduce that problem (22) has a unique solution $\mathbf{A} \in V$. A natural question is whether $\text{curl } \mathbf{A}$ does not depend on the choice of the cuts and the choice of ψ_j . For that purpose, we first state a Helmholtz type decomposition.

Lemma 3.6. *Under the previous assumptions, any $\mathbf{u} \in L^2(\Omega)^3$ admits the Helmholtz decomposition*

$$\mathbf{u} = \text{curl } \mathbf{w} + \mu \nabla \chi,$$

with $\mathbf{w} \in V$ and $\chi \in H_{\Gamma_b}^1(\Omega)$.

Proof. As usual, in a first step, we consider the unique solution $\chi \in H_{\Gamma_h}^1(\Omega)$ of

$$(\mu \nabla \chi, \nabla \xi) = (\mathbf{u}, \nabla \xi), \forall \xi \in H_{\Gamma_h}^1(\Omega).$$

Hence $\mathbf{u} - \mu \nabla \chi$ is divergence free and therefore, by Lemma 3.5 of [1], there exists $\mathbf{A} \in H^1(\Omega)^3$ such that

$$\mathbf{u} - \mu \nabla \chi = \text{curl } \mathbf{A}. \quad (30)$$

Since $(\mathbf{u} - \mu \nabla \chi) \cdot \mathbf{n} = 0$ on Γ_b , we deduce that

$$\text{curl } \mathbf{A} \cdot \mathbf{n} = 0 \text{ on } \Gamma_b.$$

Hence according to Lemma 3.3, we deduce that

$$\mathbf{A} = \nabla \varphi + \mathbf{C} + \sum_{j=1}^J \alpha_j \psi_j,$$

with $\mathbf{C} \in X_0(\Omega)$ and $\varphi \in H^1(\Omega)$. Inserting this expression in (30), we get the result with $\mathbf{w} = \mathbf{C} + \sum_{j=1}^J \alpha_j \psi_j$. ■

With this result in hands, we can prove the next result.

Theorem 3.7. *Assume that $\mathbf{n} \times \mathbf{H}$ belongs to $H(\text{div}_{\Gamma_b}; \Gamma_b)$ and satisfies $\text{div}_{\Gamma_b}(\mathbf{n} \times \mathbf{H}) = 0$ on Γ_b and $\mathbf{n} \times \mathbf{H} = 0$ on $\partial \Gamma_b$. Assume further that $\mathbf{j}_s \in L^2(\Omega)^3$ satisfies*

$$\int_{\Omega} \mathbf{j}_s \cdot \nabla \varphi \, dx = 0, \forall \varphi \in H^1(\Omega),$$

and let $\mathbf{A} \in V$ be the unique solution of problem (22). Then $\text{curl } \mathbf{A}$ does not depend on the choice of the cuts and the choice of ψ_j .

Proof. Let us fix two series of cuts $\sigma_j, j = 1, \dots, J$ and $\tilde{\sigma}_j, j = 1, \dots, J$ and functions ψ_j (resp. $\tilde{\psi}_j$) fulfilling the properties described below for σ_j (resp. $\tilde{\sigma}_j$). Denote by \tilde{V} , the space defined like V with $\tilde{\psi}_j$ instead of ψ_j . Let $\mathbf{A} \in V$ (resp. $\tilde{\mathbf{A}} \in \tilde{V}$) be the solution of (22) with test functions in V (resp. \tilde{V}).

Our goal is to show that

$$\text{curl } \mathbf{A} = \text{curl } \tilde{\mathbf{A}}. \quad (31)$$

For that purpose, we first notice that

$$\int_{\Omega} \mu^{-1} \text{curl } \mathbf{A} \cdot \text{curl } \psi_j \, dx = \int_{\Omega} \mu^{-1} \text{curl } \tilde{\mathbf{A}} \cdot \text{curl } \psi_j \, dx, \forall j = 1, \dots, J. \quad (32)$$

Indeed by Lemma 3.3, we can write

$$\psi_j = \mathbf{w} + \nabla \chi,$$

with $\mathbf{w} \in \tilde{V}$ and $\chi \in H^1(\Omega)$. Therefore

$$\int_{\Omega} \mu^{-1} \operatorname{curl} \tilde{\mathbf{A}} \cdot \operatorname{curl} \psi_j \, dx = \int_{\Omega} \mu^{-1} \operatorname{curl} \tilde{\mathbf{A}} \cdot \operatorname{curl} \mathbf{w} \, dx,$$

and by the variational formulation (22) for $\tilde{\mathbf{A}}$, we get

$$\begin{aligned} \int_{\Omega} \mu^{-1} \operatorname{curl} \tilde{\mathbf{A}} \cdot \operatorname{curl} \psi_j \, dx &= \int_{\Omega} \mathbf{j}_s \cdot \mathbf{w} \, dx + \int_{\Gamma_b} (\mathbf{n} \times \mathbf{H}) \cdot \mathbf{w} \, d\sigma \\ &= \int_{\Omega} \mathbf{j}_s \cdot (\psi_j - \nabla \chi) \, dx + \int_{\Gamma_b} (\mathbf{n} \times \mathbf{H}) \cdot (\psi_j - \nabla \chi) \, d\sigma. \end{aligned} \quad (33)$$

By the assumption on \mathbf{j}_s , we clearly have

$$\int_{\Omega} \mathbf{j}_s \cdot (\psi_j - \nabla \chi) \, dx = \int_{\Omega} \mathbf{j}_s \cdot \psi_j \, dx.$$

Furthermore, let us show that

$$\int_{\Gamma_b} (\mathbf{n} \times \mathbf{H}) \cdot \nabla \chi \, d\sigma = 0. \quad (34)$$

Indeed we have

$$\int_{\Gamma_b} (\mathbf{n} \times \mathbf{H}) \cdot \nabla \chi \, d\sigma = \int_{\Gamma_b} (\mathbf{n} \times \mathbf{H}) \cdot \nabla_{\tau} \chi \, d\sigma,$$

and by Green formula on Γ_b and the assumptions on $\mathbf{n} \times \mathbf{H}$, we deduce that (34) holds. These two properties imply that

$$\int_{\Omega} \mu^{-1} \operatorname{curl} \tilde{\mathbf{A}} \cdot \operatorname{curl} \psi_j \, dx = \int_{\Omega} \mathbf{j}_s \cdot \psi_j \, dx + \int_{\Gamma_b} (\mathbf{n} \times \mathbf{H}) \cdot \psi_j \, d\sigma,$$

and we conclude that (32) holds owing to the variational formulation (22) for \mathbf{A} .

Now take an arbitrary element $\mathbf{u} \in L^2(\Omega)^3$, then by Lemma 3.6, we may write

$$\mathbf{u} = \mu \nabla \chi + \operatorname{curl} \mathbf{w}_0 + \sum_{j=1}^N \alpha_j \operatorname{curl} \psi_j,$$

with $\chi \in H_{\Gamma_b}^1(\Omega)$, $\mathbf{w}_0 \in X_0(\Omega)$ and $\alpha_j \in \mathbb{C}$. Therefore

$$\begin{aligned} \int_{\Omega} \mu^{-1} \operatorname{curl} (\mathbf{A} - \tilde{\mathbf{A}}) \cdot \mathbf{u} \, dx &= \int_{\Omega} \operatorname{curl} (\mathbf{A} - \tilde{\mathbf{A}}) \cdot \nabla \chi \, dx \\ &+ \int_{\Omega} \mu^{-1} \operatorname{curl} (\mathbf{A} - \tilde{\mathbf{A}}) \cdot \operatorname{curl} \mathbf{w}_0 \, dx \\ &+ \sum_{j=1}^N \alpha_j \int_{\Omega} \mu^{-1} \operatorname{curl} (\mathbf{A} - \tilde{\mathbf{A}}) \cdot \operatorname{curl} \psi_j \, dx. \end{aligned}$$

The last term of this right-hand side is zero due to (32), the second term is zero because $\mathbf{w}_0 \in X_0(\Omega)$ and due to the variational formulation (22). Hence it remains the first term that can be transformed due to Green's formula into

$$\int_{\Omega} \operatorname{curl}(\mathbf{A} - \tilde{\mathbf{A}}) \cdot \nabla \chi \, dx = \langle \operatorname{curl}(\mathbf{A} - \tilde{\mathbf{A}}) \cdot \mathbf{n}, \chi \rangle_{\Gamma_b}.$$

This right-hand side is zero as $\mathbf{A} \in V$ and $\tilde{\mathbf{A}} \in \tilde{V}$. In conclusion, we have

$$\int_{\Omega} \mu^{-1} \operatorname{curl}(\mathbf{A} - \tilde{\mathbf{A}}) \cdot \mathbf{u} \, dx = 0, \forall \mathbf{u} \in L^2(\Omega)^3,$$

which proves (31). ■

Remark 3.1. Let us notice that we have shown in the previous proof that

$$\int_{\Gamma_b} (\mathbf{n} \times \mathbf{H}) \cdot \psi_j \, d\sigma = \int_{\Gamma_b} (\mathbf{n} \times \mathbf{H}) \cdot \mathbf{w} \, d\sigma,$$

when ψ_j admits the splitting

$$\psi_j = \mathbf{w} + \nabla \chi,$$

with $\mathbf{w} \in \tilde{V}$ and $\chi \in H^1(\Omega)$. Since w can be splitted up as

$$\mathbf{w} = \mathbf{w}_0 + \sum_{k=1}^J \beta_{j,k} \tilde{\psi}_k,$$

with $w_0 \in X_0(\Omega)$ and $\beta_{j,k} \in \mathbb{R}$, by our assumptions on \mathbf{H} on Γ_b , we also have

$$\int_{\Gamma_b} (\mathbf{n} \times \mathbf{H}) \cdot \mathbf{w} \, d\sigma = \sum_{k=1}^J \beta_{j,k} \delta_k.$$

Therefore we conclude that

$$\delta_j = \sum_{k=1}^J \beta_{j,k} \delta_k.$$

Since this property is valid for all $j = 1, \dots, J$ and the δ_j are arbitrary, we conclude that

$$\beta_{j,k} = 0, \forall j, k = 1, \dots, J : j \neq k \text{ and } \beta_{j,j} = 1, \forall j = 1, \dots, J.$$

Note that it is also possible to prove directly this property by using the jump properties of the φ_j 's and the $\tilde{\varphi}_j$'s.

3.2 Discrete weak formulations

As in subsection 2.2, we consider a conforming mesh \mathcal{T}_h of Ω made of tetrahedra and will approximate the solution $\mathbf{A} \in V$ of (24) by first order edge elements. Clearly the approximation of the space $X_0(\Omega)$ can be made either using the Coulomb gauge or the tree-cotree gauge. Here we further need to approximate the functions ψ_j introduced before. For that purpose, each cut σ_j is first replaced by a discrete one $\sigma_{j,h}$ that is made of edges of the triangulation included into Γ_b so that the family $\sigma_{j,h}$, $j = 1, \dots, J$, keeps the same properties than the σ_j 's. Now for each j , we split up each node along $\bar{\sigma}_{j,h}$ into two "nodes" one from above and one from below and define $\varphi_{j,h}$ on Γ_b° as the unique element that is piecewise polynomial on the triangulation which is zero at all nodes of $\partial\Gamma_b \setminus \bar{\sigma}_{j,h}$, at all interior nodes of Γ_b° , at all nodes of $\sigma_{j',h}$ for $j' \neq j$, at all nodes above $\bar{\sigma}_{j,h}$ and finally is equal to one at all nodes below $\bar{\sigma}_{j,h}$. This defines uniquely $\varphi_{j,h}$ in Γ_b° , but the most important fact is that $\nabla_{\Gamma_b} \varphi_{j,h}$ is well defined on the whole Γ_b and belongs to $H(\text{curl}, \Gamma_b)$. Hence we define $\psi_{j,h}$ as the unique element in

$$ND_h(\Omega) := \left\{ \mathbf{A}_h \in H(\text{curl}, \Omega); \mathbf{A}_{h|T} \in \mathcal{ND}_1(T), \forall T \in \mathcal{T}_h \right\},$$

such that all degrees of freedom coincides with the ones of $\nabla_{\Gamma_b} \varphi_{j,h}$ on Γ_b and are equal to zero elsewhere. With such a definition, as approximated space of V , we can then chose either

$$V_h = X_{0,h}(\Omega) \oplus \text{Span} \{ \psi_{j,h} \}_{j=1}^J,$$

or

$$V_{h,\tau} = X_{h,\tau}(\Omega) \oplus \text{Span} \{ \psi_{j,h} \}_{j=1}^J.$$

Obviously these spaces depend on the chosen family of cuts but we do not mention this dependence for the sake of shortness.

Now the two approximation schemes of (24) consists in looking for $\mathbf{A}_h \in V_h$ (resp. $\mathbf{A}_{h,\tau} \in V_{h,\tau}$) solution of

$$\int_{\Omega} \mu^{-1} \text{curl} \mathbf{A}_h \cdot \text{curl} \mathbf{A}'_h dx = \int_{\Omega_s} \mathbf{j}_{s,h} \cdot \mathbf{A}'_h dx + \sum_{j=1}^J \delta_j \beta'_j, \quad (35)$$

for all $\mathbf{A}'_h \in V_h$ (resp. $\mathbf{A}'_h \in V_{h,\tau}$) splitted in the form

$$\mathbf{A}'_h = \mathbf{A}'_{0,h} + \sum_{j=1}^J \beta'_j \psi_{j,h},$$

with $\mathbf{A}'_{0,h} \in X_{0,h}(\Omega)$ (resp. $\mathbf{A}'_{0,h} \in X_{h,\tau}(\Omega)$).

Both problems are well-posed. Indeed since V_h and $V_{h,\tau}$ are finite-dimensional it suffices to show that any element \mathbf{A}_h from V_h or $V_{h,\tau}$ that is curl free is zero. But as in Lemma 2.1 in such a case we have

$$\mathbf{A}_h = \nabla w_h,$$

with $w_h \in H_h^1(\Omega)$ and the end of the proof of Lemma 3.4 allows to conclude that $\mathbf{A}_h = \mathbf{0}$.

Exactly as in Corollary 2.1 (resp. 2.2), by using (16) (resp. the discrete Helmholtz decomposition), one can prove that if the cuts are fixed, then the solution $\mathbf{A}_h \in V_h$ of (35), the solution $\mathbf{A}_{h,\tau} \in V_{h,\tau}$ of (35) and the solution $\mathbf{A}_{h,\tau^*} \in V_{h,\tau^*}$ of (35) with another tree τ^* have the same curl, if we assume that $\mathbf{j}_{s,h}$ satisfies (14).

We now show that if two families of cuts are used, then the solutions of (35) have the same curl under an additional condition on $\mathbf{j}_{s,h}$.

Theorem 3.8. *Let $\sigma_{j,h}, \tilde{\sigma}_{j,h}, j = 1, \dots, J$ be two families of cuts of Γ_b . Denote by \tilde{V}_h the approximated space corresponding to the cuts $\tilde{\sigma}_{j,h}$ and let $\tilde{\mathbf{A}}_h \in \tilde{V}_h$ be the solution of (35) with test-functions in \tilde{V}_h . If we assume that $\mathbf{j}_{s,h}$ satisfies*

$$(\mathbf{j}_{s,h}, \nabla w_h) = 0, \forall w_h \in H_h^1(\Omega), \quad (36)$$

then

$$\text{curl } \mathbf{A}_h = \text{curl } \tilde{\mathbf{A}}_h. \quad (37)$$

Proof. Exactly as in the continuous case (see the proof of Theorem 3.7), we mainly need to show that

$$\int_{\Omega} \mu^{-1} \text{curl } \mathbf{A}_h \cdot \text{curl } \psi_{j,h} dx = \int_{\Omega} \mu^{-1} \text{curl } \tilde{\mathbf{A}}_h \cdot \text{curl } \psi_{j,h} dx, \forall j = 1, \dots, J. \quad (38)$$

For that goal, we show that $\psi_{j,h}$ can be splitted up as

$$\psi_{j,h} = \mathbf{w}_h + \nabla \chi_h, \quad (39)$$

with $\mathbf{w}_h \in \tilde{V}_h$ and $\chi_h \in H_h^1(\Omega)$. Indeed Lemma 3.3 guarantees that

$$\psi_{j,h} = \nabla \varphi + \mathbf{C} + \sum_{k=1}^J \alpha_k \tilde{\psi}_{k,h},$$

with $\varphi \in H^1(\Omega)$, $\mathbf{C} \in X_0(\Omega)$ and some coefficients α_k . Hence taking the tangential trace on Γ_b , we have

$$\mathbf{n} \times (\psi_{j,h} \times \mathbf{n}) = \mathbf{n} \times (\nabla \varphi \times \mathbf{n}) + \sum_{k=1}^J \alpha_k (\mathbf{n} \times (\tilde{\psi}_{k,h} \times \mathbf{n})) \quad \text{on } \Gamma_b.$$

Since by construction, $\mathbf{n} \times (\psi_{j,h} \times \mathbf{n})$ and $\mathbf{n} \times (\tilde{\psi}_{k,h} \times \mathbf{n})$ are constant on each triangle included into Γ_b , we deduce that φ is piecewise \mathbb{P}_1 on Γ_b . Extending this restriction of φ to Γ_b into an element φ_h of $H_h^1(\Omega)$ by taking zero values at all other nodes of the triangulation, we find that

$$\mathbf{C}_h = \psi_{j,h} - \nabla \varphi_h - \sum_{k=1}^J \alpha_k \tilde{\psi}_{k,h},$$

belongs to $X_h(\Omega)$. If finally C_h is not discrete divergence free, we subtract to it $\psi_h \in H_{\Gamma_b,h}^1(\Omega)$ solution of

$$\int_{\Omega} \nabla \psi_h \cdot \nabla \xi_h \, dx = \int_{\Omega} \mathbf{C}_h \cdot \nabla \xi_h \, dx, \forall \xi_h \in H_{\Gamma_b,h}^1(\Omega).$$

This yields (39) with

$$\mathbf{w}_h = \mathbf{C}_h - \nabla \psi_h + \sum_{k=1}^J \alpha_k \tilde{\psi}_{k,h}$$

that indeed belongs to \tilde{V}_h and with $\chi_h = \varphi_h + \psi_h$. By Remark 3.1, we further notice that $\alpha_j = 1$ and $\alpha_k = 0$, if $k \neq j$. Hence we have

$$\mathbf{w}_h = \mathbf{w}_{h,0} + \tilde{\psi}_{j,h}, \quad (40)$$

with $\mathbf{w}_{h,0} \in X_{0,h}(\Omega)$.

With the expansion (39), we then have

$$\int_{\Omega} \mu^{-1} \operatorname{curl} \tilde{\mathbf{A}}_h \cdot \operatorname{curl} \psi_{j,h} \, dx = \int_{\Omega} \mu^{-1} \operatorname{curl} \tilde{\mathbf{A}}_h \cdot \operatorname{curl} \mathbf{w}_h \, dx.$$

By the variational formulation (35) for $\tilde{\mathbf{A}}_h \in \tilde{V}_h$ and the expression (40), we obtain

$$\int_{\Omega} \mu^{-1} \operatorname{curl} \tilde{\mathbf{A}}_h \cdot \operatorname{curl} \psi_{j,h} \, dx = \int_{\Omega_s} \mathbf{j}_{s,h} \cdot \mathbf{w}_h \, dx + \delta_j.$$

Again using (39) and by our assumption on $\mathbf{j}_{s,h}$, we have

$$\begin{aligned} \int_{\Omega} \mu^{-1} \operatorname{curl} \tilde{\mathbf{A}}_h \cdot \operatorname{curl} \psi_{j,h} \, dx &= \int_{\Omega_s} \mathbf{j}_{s,h} \cdot (\psi_{j,h} - \nabla \chi_h) \, dx + \delta_j \\ &= \int_{\Omega_s} \mathbf{j}_{s,h} \cdot \psi_{j,h} \, dx + \delta_j. \end{aligned}$$

This proves the identity (38) by using the variational formulation for \mathbf{A}_h .

Now by (39) we further notice that

$$\operatorname{curl} V_h \subset \operatorname{curl} \tilde{V}_h,$$

and hence by symmetry, one gets

$$\operatorname{curl} V_h = \operatorname{curl} \tilde{V}_h.$$

Consequently if we take an arbitrary element $\mathbf{v}_h \in V_h$ it can be written as

$$\mathbf{v}_h = \mathbf{v}_{h,0} + \sum_{j=1}^J \beta'_j \psi_{j,h},$$

with $\mathbf{v}_{h,0} \in X_{0,h}(\Omega)$ and some constant β'_j , and therefore

$$\begin{aligned} \int_{\Omega} \mu^{-1} \operatorname{curl}(\mathbf{A}_h - \tilde{\mathbf{A}}_h) \cdot \operatorname{curl} \mathbf{v}_h \, dx &= \int_{\Omega} \mu^{-1} \operatorname{curl}(\mathbf{A}_h - \tilde{\mathbf{A}}_h) \cdot \operatorname{curl} \mathbf{v}_{h,0} \, dx \\ &+ \sum_{j=1}^J \beta'_j \operatorname{curl}(\mathbf{A}_h - \tilde{\mathbf{A}}_h) \cdot \operatorname{curl} \psi_{j,h} \, dx. \end{aligned}$$

Using (38), the second term is zero, while the first term is zero due to the variational formulation for \mathbf{A}_h and $\tilde{\mathbf{A}}_h$ (recalling that $\mathbf{v}_{h,0} \in X_{0,h}(\Omega)$). This means that

$$\int_{\Omega} \mu^{-1} \operatorname{curl}(\mathbf{A}_h - \tilde{\mathbf{A}}_h) \cdot \operatorname{curl} \mathbf{v}_h \, dx = 0, \forall \mathbf{v}_h \in V_h.$$

As $\operatorname{curl}(\mathbf{A}_h - \tilde{\mathbf{A}}_h)$ belongs to $\operatorname{curl} V_h$, the previous property directly implies that $\operatorname{curl}(\mathbf{A}_h - \tilde{\mathbf{A}}_h) = \mathbf{0}$. ■

By transitivity, this Theorem and the properties stated before it allow to conclude that if the tree-cotree gauge is used with two families of cuts, then the two solutions will have the same curl (independently of the choice of the tree); they will further have the same curl as the solutions with the Coulomb gauge.

4 Numerical results

4.1 The discrete divergence free property of $\mathbf{j}_{s,h}$

From the discrete and practical point of view, several possibilities occur for the definition of $\mathbf{j}_{s,h}$ used as a source term in (11) or (35). The goal is to ensure (14) which is, as we saw above in the theoretical results, a fundamental property to be satisfied. Of course, defining $\mathbf{j}_{s,h} = I_h \mathbf{j}_s$, with I_h the Lagrange interpolation operator (leading to some discrete nodal values at the vertices of the mesh), should not be a good solution, since $I_h \mathbf{j}_s$ is *a priori* no more divergence free.

- We can define $\mathbf{j}_{s,h} = I_{RT0} \mathbf{j}_s$, where I_{RT0} is the Raviart-Thomas interpolation operator, leading to the computation of the flux through the faces of the triangulation. Even if it theoretically respects property (14), some problems can nevertheless appear because of the lack of accuracy in the numerical integration.
- Another possibility, oftenly used in the literature to overcome these difficulties, is to impose strongly condition (14) via the computation of a discrete electric vector potential $\mathbf{h}_{s,h} \in H(\operatorname{curl}, \Omega)$ such that $\operatorname{curl} \mathbf{h}_{s,h}$ is an approximation of \mathbf{j}_s and to define $\mathbf{j}_{s,h} = \operatorname{curl} \mathbf{h}_{s,h}$. The construction of such an $\mathbf{h}_{s,h}$ needs as a source the continuous form of \mathbf{j}_s , that is usually not adapted to the approximation of Ω_s by $\Omega_{s,h}$. Even if in some cases a correct curl \mathbf{A}_h can nevertheless be obtained, this can also lead to numerical inaccuracies.

- We can also consider a pre-processing problem to define $\mathbf{j}_{s,h}$, by the use of a penalization problem [6], in order to ensure that $\mathbf{j}_{s,h}$ will be in the range of the curl curl operator.
- Finally, another technique consists in looking for $\mathbf{j}_{s,h}$ in the form

$$\mathbf{j}_{s,h} = I_h \mathbf{j}_s + \nabla w_h, \quad (41)$$

with $w_h \in H_{\Gamma_b,h}^1(\Omega)$ the unique solution of :

$$(I_h \mathbf{j}_s + \nabla w_h, \nabla w'_h) = 0, \forall w'_h \in H_{\Gamma_b,h}^1(\Omega). \quad (42)$$

Property (42) directly implies that $\mathbf{j}_{s,h}$ satisfies (14). Note further that in (13), if we take for $\mathbf{j}_{s,h}$ the one from (41), then the Lagrange multiplier ξ_h is zero, while if for $\mathbf{j}_{s,h}$ we take $I_h \mathbf{j}_s$, then the Lagrange multiplier $\xi_h = w_h$ is solution of (42). Hence if we choose to solve problem (13), we do not need to use a correction of $I_h \mathbf{j}_s$.

In order to illustrate some of the theoretical results obtained in the previous sections, two benchmarks are now considered.

4.2 The coil surrounding a magnetic core

The first one is defined by a coil around a magnetic core. A current density \mathbf{j}_s is imposed in the coil in order to generate a magnetic induction \mathbf{B} in the core. Two configurations are studied, as displayed in Figure 4 (the coil is in red, the core in blue). For both of them, the relative permeability of the core is equal to $\mu_{core} = 1000$, whereas the one of the coil is the same as in the air ($\mu_{coil} = 1$). On the first configuration, the coil and the core are separated by an air gap (see Figure (4a)). On the second configuration, there is no air gap so that the coil and the core are in contact (see Figure (4b)). For each configuration, we consider a cube surrounding the device, which is cut in two along a symmetry plane to define the domain Ω , leading respectively to the configurations displayed in Figure (4c) and Figure (4d). Problem (11) is solved in Ω with a source term supported by the coil, Γ_h being defined by the symmetry plane, and Γ_b corresponding to the five other faces of the cube (that is then simply connected).

4.2.1 Source current density discretization

A first test consists in computing the magnetic induction $\mathbf{B}_h = \text{curl} \mathbf{A}_h$, using two kinds of discretizations of \mathbf{j}_s on the configuration 1. First, we define $\mathbf{j}_{s,h} = I_h \mathbf{j}_s$, so that the continuous current density field \mathbf{j}_s is interpolated without any correction (see Figure (5a)). The l^∞ norm of $\mathbf{j}_{s,h}$ is the same in the whole domain and equal to $\|\mathbf{j}_{s,h}\|_{l^\infty} = 1.96e + 06$. A tree-co tree gauge condition is used to evaluate \mathbf{B}_h . As we can see in Figure (5d), the obtained magnetic induction \mathbf{B}_h is in good agreement with its qualitatively expected behavior. Second, we consider $\mathbf{j}_{s,h} = I_h \mathbf{j}_s + \nabla w_h$, where ∇w_h is

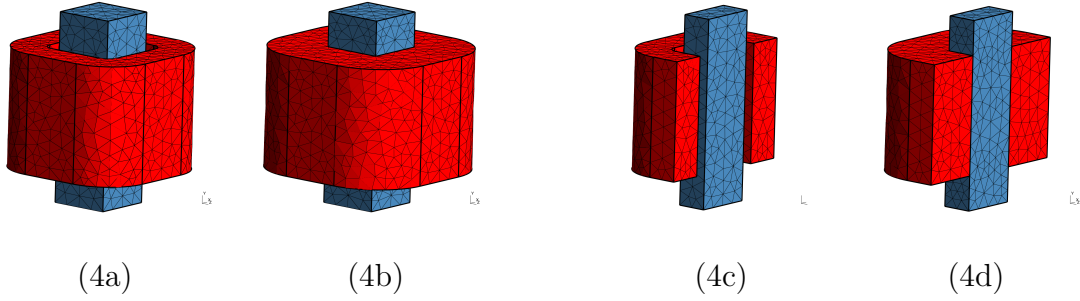

Figure 4: The two configurations. (4a) and (4c) : configuration 1. (4b) and (4d) : configuration 2.

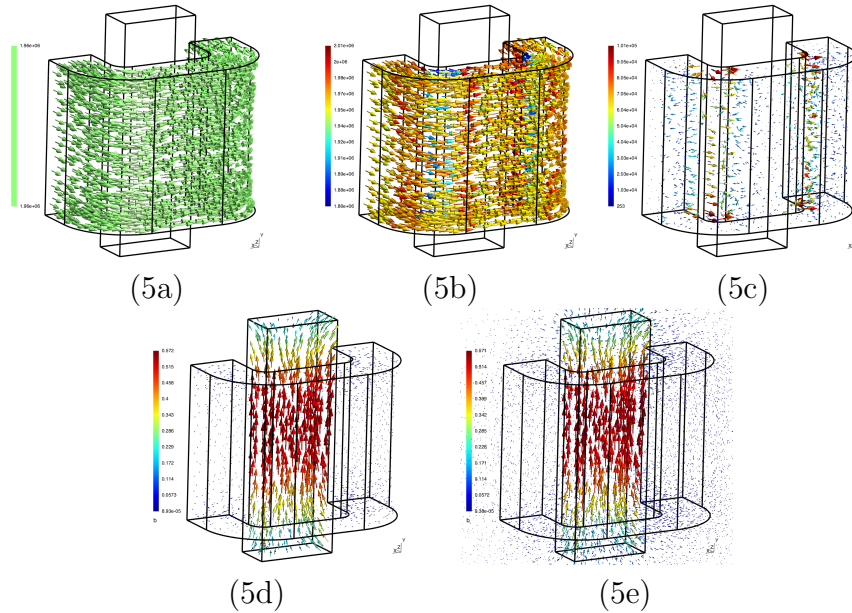

Figure 5: Configuration 1. (5a) : $\mathbf{j}_{s,h} = I_h \mathbf{j}_s$. (5b) : $\mathbf{j}_{s,h} = I_h \mathbf{j}_s + \nabla w_h$. (5c) : ∇w_h . (5d) : \mathbf{B}_h in the case $\mathbf{j}_{s,h} = I_h \mathbf{j}_s$. (5e) : \mathbf{B}_h in the case $\mathbf{j}_{s,h} = I_h \mathbf{j}_s + \nabla w_h$.

the correction needed to ensure the weak-divergence free condition of $\mathbf{j}_{s,h}$. Now, the l^∞ norm of $\mathbf{j}_{s,h}$ is bounded between $1.86e + 06$ and $2.01e + 06$ (see Figure (5b)), and the main correction ∇w_h has been imposed in the vicinity of the corners of the coil (see Figure (5c)). As we can see in Figure (5e), the magnetic induction \mathbf{B}_h is nearly the same as the one obtained before in Figure (5d). Its maximal l^∞ norm is equal to 0.571 instead of 0.572, corresponding to a difference in the order of 0.17 %.

The same test is now performed on the configuration 2. Once again, without any correction, the interpolated current density field $\mathbf{j}_{s,h} = I_h \mathbf{j}_s$ has the same l^∞ norm on the whole domain (see Figure (6a)) : $\|\mathbf{j}_{s,h}\|_{l^\infty} = 1.18e + 06$. But this time, as we can see in Figure (6d), the obtained magnetic induction \mathbf{B}_h is clearly irrelevant. If we consider $\mathbf{j}_{s,h} = I_h \mathbf{j}_s + \nabla w_h$, where ∇w_h is the correction needed to ensure the weak divergence free condition of $\mathbf{j}_{s,h}$, the l^∞ norm of $\mathbf{j}_{s,h}$ is bounded between $1.16e + 06$ and $1.20e + 06$

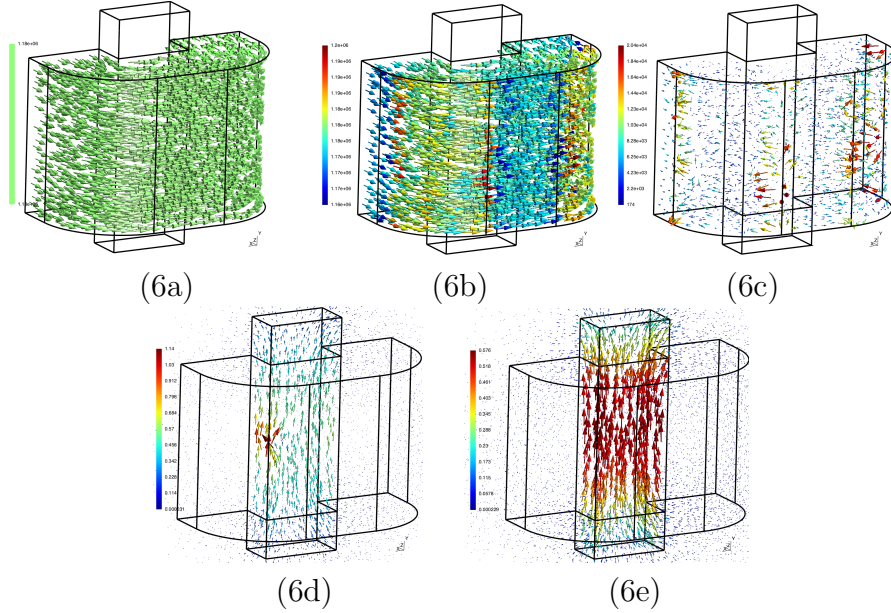

Figure 6: Configuration 2. (6a) : $\mathbf{j}_{s,h} = I_h \mathbf{j}_s$. (6b) : $\mathbf{j}_{s,h} = I_h \mathbf{j}_s + \nabla w_h$. (6c) : ∇w_h . (6d) : \mathbf{B}_h in the case $\mathbf{j}_{s,h} = I_h \mathbf{j}_s$. (6e) : \mathbf{B}_h in the case $\mathbf{j}_{s,h} = I_h \mathbf{j}_s + \nabla w_h$.

(see Figure (6b)), and the main correction ∇w_h is displayed in Figure (6c). As we can see in Figure (6e), the magnetic induction \mathbf{B}_h is this time satisfactory.

This first test allows to underline the fact that if, for some simple cases like the configuration 1, the discretization of \mathbf{j}_s by the standard Lagrange interpolant I_h does not dramatically affect the solution \mathbf{B}_h , this is not the case for more complex cases as the configuration 2 for which the weak divergence free condition of the source field is essential. Hence from now, we will always consider the source term $\mathbf{j}_{s,h}$ fullfilling the weak discrete divergence free property.

4.2.2 gauge condition on \mathbf{A}_h

Now, we come back to the configuration 2, and we compare the obtained magnetic induction $\mathbf{B}_h = \text{curl } \mathbf{A}_h$ and vector potential \mathbf{A}_h when a Coulomb gauge condition is imposed instead of a tree-co tree one. Figure (7a) displays the value of \mathbf{B}_h obtained with the Coulomb gauge. As expected, it is exactly the same as in Figure (6e), illustrating Corollary 2.2 : the way to impose the gauge condition has no impact on the value of \mathbf{B}_h . Nevertheless, the field \mathbf{A}_h is strongly impacted by the choice of the gauge condition. Figure (7b) shows the value obtained with the tree-co tree gauge, whereas Figure (7c) shows the one obtained with the Coulomb one. In the second one, the potential vector \mathbf{A}_h is far more smooth. This property may be important, for example when the field \mathbf{A}_h is used as a source field for some more complex problems. Nevertheless, the linear system to be solved is larger than in the case of the tree-co tree gauge, since in this latest

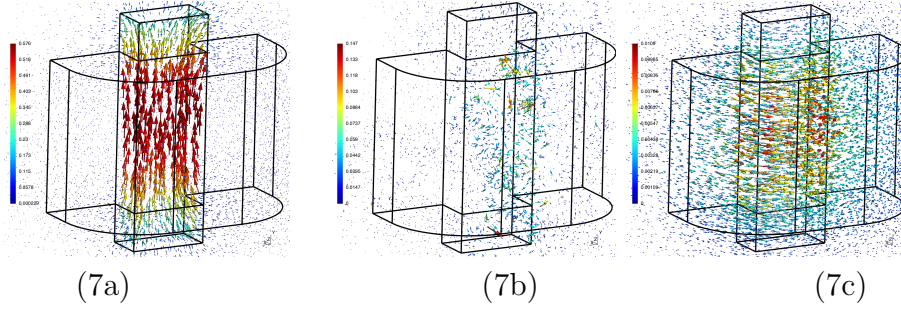

Figure 7: (7a) : \mathbf{B}_h in the case of the Coulomb gauge. (7b) : \mathbf{A}_h in the case of the tree - co tree gauge. (7c) : \mathbf{A}_h in the case of the Coulomb gauge.

case the degrees of freedom corresponding to the tree are removed from the discrete unknowns.

4.3 An example with Γ_b non simply connected

This second benchmark investigates the case for which Γ_b is not simply connected. The domain Ω is displayed in Figure (8a), and consists in a "U-shaped" domain in which a magnetic field is generated. The relative permeability is equal to $\mu = 1000$ in the whole domain. Γ_h is defined by the two faces at the bottom of Ω located in the plane $y = 0$, whereas Γ_b is composed by all the other faces of Ω , so that it is no more simply connected (similarly to the configuration displayed in Figure 3). Because of this topological feature, a cut has to be introduced. Two possible choices of cut are here compared: the cut σ_1 illustrated in Figure (8b) or the cut σ_2 from Figure (8c). There is no current density (namely, $\mathbf{j}_s = 0$ in (22)), but a magnetomotive force is imposed such that $\int_{\sigma_1} \mathbf{H} \cdot d\ell = \int_{\sigma_2} \mathbf{H} \cdot d\ell$.

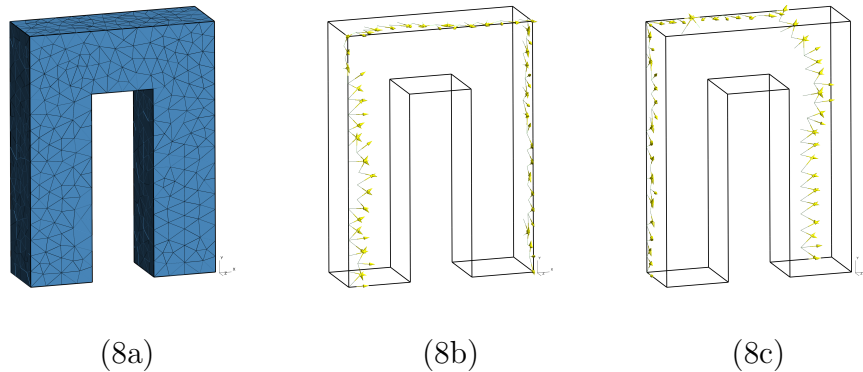
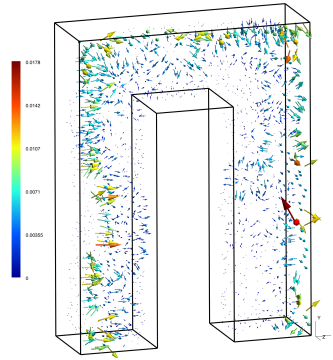
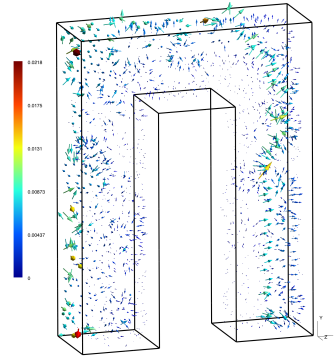

Figure 8: (8a) : The domain Ω . (8b) : Cut σ_1 . (8c) : Cut σ_2 .

As we can see in Figures (9a) and (9b), the obtained vector potential \mathbf{A}_h depends on the chosen cut. Nevertheless, the comparison between Figures (9c) and (9d) shows that the magnetic inductions \mathbf{B}_h are exactly the same for both cases, as proven in Theorem 3.8.



(9a)



(9b)

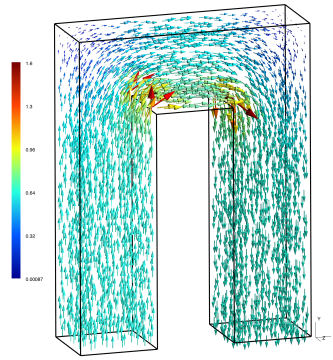

(9c)

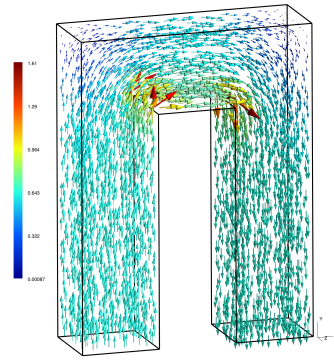

(9d)

Figure 9: (9a) : \mathbf{A}_h in the case of the cut σ_1 . (9b) : \mathbf{A}_h in the case of the cut σ_2 . (9c) : \mathbf{B}_h in the case of the cut σ_1 . (9d) : \mathbf{B}_h in the case of the cut σ_2 .

Acknowledgments

This work was supported in part by the Labex CEMPI (ANR-11-LABX-0007-01), and is dedicated to Patrick Dular, who passed away during its writing. We warmly acknowledge Professor Ruth Vazquez Sabariego for her precious help, allowing to provide the numerical simulations presented in this paper.

References

- [1] C. Amrouche, C. Bernardi, M. Dauge, and V. Girault. Vector potentials in three-dimensional nonsmooth domains. *Math. Meth. Appl. Sci.*, 21:823–864, 1998.
- [2] D. Boffi, F. Brezzi, and M. Fortin. *Mixed finite element methods and applications*, volume 44 of *Springer Series in Computational Mathematics*. Springer, Heidelberg, 2013.
- [3] A. Bossavit. *Computational electromagnetism*. Electromagnetism. Academic Press Inc., San Diego, CA, 1998. Variational formulations, complementarity, edge elements.
- [4] A. Buffa and P. Ciarlet, Jr. On traces for functional spaces related to Maxwell’s equations. I. An integration by parts formula in Lipschitz polyhedra. *Math. Methods Appl. Sci.*, 24(1):9–30, 2001.
- [5] A. Buffa and P. Ciarlet, Jr. On traces for functional spaces related to Maxwell’s equations. II. Hodge decompositions on the boundary of Lipschitz polyhedra and applications. *Math. Methods Appl. Sci.*, 24(1):31–48, 2001.
- [6] M. Darbas, J. Heleine, and S. Lohrengel. A method with penalized right-hand-side for the numerical resolution of the curl curl equation. <https://hal.archives-ouvertes.fr/hal-01681590>, Jan. 2018.
- [7] P. Dular, P. K. Peng, C. Geuzaine, N. Sadowski, and J. Batos. Dual magnetodynamic formulations and their source fields associated with massive and stranded inductors. *IEEE Transactions on Magnetics*, 36(4):1293–1299, 2000.
- [8] P. Dular, N. Sadowski, J. Batos, and W. Legros. Dual complete procedures to take stranded inductors into account in magnetic vector potential formulations. *IEEE Transactions on Magnetics*, 36(4):1600–1605, 2000.
- [9] V. Girault and P.-A. Raviart. *Finite element methods for Navier-Stokes equations, Theory and algorithms*, volume 5 of *Springer Series in Computational Mathematics*. Springer, Berlin, 1986.

- [10] A. Kameari and K. Koganezawa. Convergence of ICCG method in FEM using edge elements without gauge condition. *IEEE Transactions on Magnetics*, 33(2):1223–1226, 1997.
- [11] P. Monk. *Finite element methods for Maxwell's equations*. Numerical Mathematics and Scientific Computation. Oxford University Press, New York, 2003.
- [12] F. Rapetti, F. Dubois, and A. Bossavit. Discrete vector potentials for nonsimply connected three-dimensional domains. *SIAM J. Numer. Anal.*, 41(4):1505–1527, 2003.
- [13] Z. Ren. Influence of the R.H.S. on the convergence behaviour of the curl-curl equation. *IEEE Transactions on Magnetics*, 32(3):655–658, 1996.
- [14] A. Rodríguez and M. Raffetto. Unique solvability for electromagnetic boundary value problems in the presence of partly lossy inhomogeneous anisotropic media and mixed boundary conditions. *Math. Models Methods Appl. Sci.*, 13(4):597–611, 2003.
- [15] A. Rodriguez and A. Valli. *Eddy current approximation of Maxwell equations*. Modeling, Simulation and Applications. Springer, 2010.
- [16] Z. Tang. Estimateurs d'erreur *a posteriori* résiduels en éléments finis pour la résolution de problèmes d'électromagnétisme en formulations potentielles. *PhD-thesis, Lille 1 University, France*, 2012.