



**HAL**  
open science

## High chlorpyrifos resistance in *Culex pipiens* mosquitoes: strong synergy between resistance genes

Haoues Alout, Pierrick Labbé, A Berthomieu, Patrick Makoundou, Philippe Fort, N Pasteur, Mylene Weill

► **To cite this version:**

Haoues Alout, Pierrick Labbé, A Berthomieu, Patrick Makoundou, Philippe Fort, et al.. High chlorpyrifos resistance in *Culex pipiens* mosquitoes: strong synergy between resistance genes. *Heredity*, 2016, 116 (2), pp.224-231. 10.1038/hdy.2015.92 . hal-01944470

**HAL Id: hal-01944470**

**<https://hal.science/hal-01944470v1>**

Submitted on 27 May 2020

**HAL** is a multi-disciplinary open access archive for the deposit and dissemination of scientific research documents, whether they are published or not. The documents may come from teaching and research institutions in France or abroad, or from public or private research centers.

L'archive ouverte pluridisciplinaire **HAL**, est destinée au dépôt et à la diffusion de documents scientifiques de niveau recherche, publiés ou non, émanant des établissements d'enseignement et de recherche français ou étrangers, des laboratoires publics ou privés.

## ORIGINAL ARTICLE

# High chlorpyrifos resistance in *Culex pipiens* mosquitoes: strong synergy between resistance genes

H Alout<sup>1,2,3,5</sup>, P Labbé<sup>1,2,5</sup>, A Berthomieu<sup>1,2</sup>, P Makoundou<sup>1,2</sup>, P Fort<sup>2,4</sup>, N Pasteur<sup>1,2,6</sup> and M Weill<sup>1,2,6</sup>

We investigated the genetic determinism of high chlorpyrifos resistance (HCR), a phenotype first described in 1999 in *Culex pipiens* mosquitoes surviving chlorpyrifos doses  $\geq 1 \text{ mg l}^{-1}$  and more recently found in field samples from Tunisia, Israel or Indian Ocean islands. Through chlorpyrifos selection, we selected several HCR strains that displayed over 10 000-fold resistance. All strains were homozygous for resistant alleles at two main loci: the *ace-1* gene, with the resistant *ace-1<sup>R</sup>* allele expressing the insensitive G119S acetylcholinesterase, and a resistant allele of an unknown gene (named *T*) linked to the sex and *ace-2* genes. We constructed a strain carrying only the *T*-resistant allele and studied its resistance characteristics. By crossing this strain with strains harboring different alleles at the *ace-1* locus, we showed that the resistant *ace-1<sup>R</sup>* and the *T* alleles act in strong synergy, as they elicited a resistance 100 times higher than expected from a simple multiplicative effect. This effect was specific to chlorpyrifos and parathion and was not affected by synergists. We also examined how HCR was expressed in strains carrying other *ace-1*-resistant alleles, such as *ace-1<sup>V</sup>* or the duplicated *ace-1<sup>D</sup>* allele, currently spreading worldwide. We identified two major parameters that influenced the level of resistance: the number and the nature of the *ace-1*-resistant alleles and the number of *T* alleles. Our data fit a model that predicts that the *T* allele acts by decreasing chlorpyrifos concentration in the compartment targeted in insects.

Heredity (2016) 116, 224–231; doi:10.1038/hdy.2015.92; published online 14 October 2015

## INTRODUCTION

In insects, resistance to organophosphate (OP) insecticides is due to increased detoxification by carboxylesterases or cytochrome *P*450 oxidases (metabolic resistance), or to mutations of the synaptic acetylcholinesterase (AChE1, target-site resistance) that becomes less sensitive to inhibition by these insecticides (Labbé *et al.* 2011). In the mosquito *Culex pipiens*, various amplified esterases (encoded by the *Ester* super locus) and two substitutions on the AChE1 (encoded by the *ace-1* gene) have been identified; they confer resistance to a large variety of OP and carbamate insecticides. Mutations at the *ace-1* gene include the G119S and the F290V substitutions (the *R* and *V* alleles, respectively, Weill *et al.*, 2003; Alout *et al.*, 2007), as well as several duplications (*D* alleles) containing, in tandem, a susceptible copy (*S*) and a resistant copy (*R* or *V*, Labbé *et al.*, 2007; Alout *et al.*, 2009).

In 1999, Pasteur *et al.* described a high resistance to the OP chlorpyrifos (>10 000-fold) in populations collected in Tunisia, which was investigated in the Gara strain, homozygous for the *ace-1<sup>R</sup>* allele (Pasteur *et al.*, 1999). Gara displayed the same propoxur resistance as the reference strain SR (Berticat *et al.*, 2002), also homozygous for the *ace-1<sup>R</sup>* allele, but differed strongly in resistance to chlorpyrifos, with Gara strain being 1000-fold more resistant than SR. This high chlorpyrifos resistance (HCR) in Gara was not affected by inhibitors of carboxylesterases or cytochrome *P*450 oxidases. Bioassays with several insecticides suggested that HCR in the Gara

strain was due to a single major gene (or a group of tightly linked genes), distinct from *ace-1*, but epistatic with and/or genetically linked to it. However, as rearing of the Gara strain was discontinued, no further study was undertaken.

In 2003 and 2005, we again identified HCR (mosquito larvae surviving a chlorpyrifos dose of  $1 \text{ mg l}^{-1}$ ) in *C. pipiens* from Tunisia and observed it in another Mediterranean country (Israel) and in Mayotte Island (Indian Ocean). The present study was undertaken to analyze in more details the underlying HCR mechanism(s) with two major questions in mind: (1) is HCR due to the same gene in all regions? and (2) what is the precise relationship between the gene(s) coding HCR and the *ace-1* gene (genetic linkage or epistasis)? Here we report on (1) the thorough genetic study of HCR based on extensive crossing experiments; (2) the isolation and characterization of the Madra strain that contains only the major genetic factor (*T*) involved in HCR and lacks all other known resistance alleles at the *Ester* or *ace-1* loci; and (3) the study of HCR expression in mosquitoes with different genotypes at the *T* and *ace-1* loci, obtained by crossing various strains.

## MATERIALS AND METHODS

### Strains and crossing experiments

Four reference strains were used: Slab, SR, Ducos and HomoVAL. Slab is the susceptible reference strain (Georghiou *et al.*, 1966) isolated from a Californian population (that is, subspecies *Culex p. quinquefasciatus*). SR is resistant to OPs

<sup>1</sup>CNRS, IRD, ISEM–UMR, Montpellier, France; <sup>2</sup>University of Montpellier, Montpellier, France; <sup>3</sup>Arthropod-Borne and Infectious Diseases Laboratory, Colorado State University, Fort Collins, CO, USA and <sup>4</sup>CNRS, CRBM–UMR, Montpellier, France

Correspondence: Dr P Labbé, ISEM–Université Montpellier 2, Place E Bataillon, CC065, 34095 Montpellier Cedex 05, France.

E-mail: pierrick.labbe@univ-montp2.fr

<sup>5</sup>These two authors contributed equally to this work.

<sup>6</sup>These two authors contributed equally to this work.

Received 18 March 2015; revised 19 June 2015; accepted 18 August 2015; published online 14 October 2015

and carbamates through insensitive AChE1 and is homozygous for the *ace-1<sup>R</sup>* allele, in the Slab genetic background (Berticat *et al.*, 2002). Ducos is homozygous for the *ace-1<sup>DI</sup>* allele, a duplicated allele with a susceptible copy and the resistant *R* copy, in the Slab genetic background (Labbe *et al.*, 2007). HomoVAL is homozygous for the *ace-1<sup>V</sup>* allele (Alout *et al.*, 2009).

Four new strains studied here were derived from field collections performed in Tunisia (Bismuth, collected in the Tunis area in 2003, and Sousse, collected in 2005), in Israel (Yatouch, collected in Tel Aviv in 2010) and in Mayotte Island (Mayotte, collected in Tsoundzou in 2010). Strains from Tunisia and Israel are from the *C. p. pipiens* subspecies, whereas the one from Mayotte is from *C. p. quinquefasciatus*. A last strain, Madra, was derived from Sousse for the present study. The characteristics of all strains are given in Supplementary Table S1. Strains were reared in standard insectarium conditions ( $27 \pm 1$  °C,  $70 \pm 8\%$  relative humidity and 12:12 light and dark photoperiod). Mass crosses were used in most experiments. Pupae were isolated individually in 10 ml tubes containing 1 ml of tap water. Adults were sorted by sex upon emergence and released in the appropriate cages ( $25 \times 25 \times 25$  cm). When necessary, larvae were cured of *Wolbachia* infection to avoid interstrain cytoplasmic incompatibility: they were then reared in water containing tetracycline hydrochloride ( $20 \text{ mg l}^{-1}$ , Sigma Aldrich, St Louis, MI, USA) during three generations, followed by one generation of rearing in clear water before performing crosses (Duron *et al.*, 2006).

### Bioassays and insecticide selections

Bioassays were conducted on sets of 20 larvae in plastic cups containing 99 ml of tap water and 1 ml of insecticide solution in ethanol. Mortalities were recorded after a 24-h exposure. Each test was replicated at least two times on larvae reared in different tanks. The insecticides tested were of technical grade and included chlorpyrifos-ethyl (99% (active ingredient), Dow Chemical, Midland, MI, USA), chlorpyrifos-methyl (99.5% purity, Dr Ehrenstorfer GmbH, Augsburg, Germany), chlorpyrifos-oxon ( $10 \text{ ng } \mu\text{l}^{-1}$ , Dr Ehrenstorfer GmbH), propoxur (99.9% (active ingredient), Bayer AC, Leverkusen, Germany), temephos (97% HPLC, Sigma Aldrich), parathion-methyl (98.5% purity, Dr Ehrenstorfer GmbH) and paraoxon-methyl (99% purity, Dr Ehrenstorfer GmbH). Synergists DEF (S,S,S-tributyl-phosphorotrithioate; Interchim, Montluçon, France) and PB (piperonyl butoxide; Fluka AG, Buchs, Switzerland) were used in bioassays at the concentration of 0.8 and  $5 \text{ mg l}^{-1}$ , respectively, 4 h before adding the insecticide. DEF is an inhibitor of carboxylesterases and of glutathione-S-transferases; PB is an inhibitor of cytochrome oxidases.

Dose-mortality responses were analyzed using the R free software (<http://www.r-project.org/>) and the BioRssay v6.01 script of Milesi *et al.* (2013). The following parameters were analyzed or computed: (1) the linearity and slope of dose-mortality responses; (2) insecticide concentrations inducing 50% mortality ( $\text{LC}_{50}$ ) with their 95% confidence intervals; and (3) the resistance ratio of a given strain as compared with a reference strain at  $\text{LC}_{50}$  ( $\text{RR}_{50}$ ) and their 95% confidence intervals. The effect of synergists on dose-mortality responses was evaluated by the synergism ratio (LC in absence synergist/LC in presence synergist) at  $\text{LC}_{50}$  ( $\text{SR}_{50}$ ). Mortality responses were considered significantly different ( $P < 0.05$ ) when their 95% confidence limits did not overlap.

Chlorpyrifos selections of strains were done in the same conditions as bioassays, using ~50 larvae per cup. The field collection from Sousse was selected with  $10 \text{ mg l}^{-1}$  chlorpyrifos during three successive generations. Cages were then set with one male and five virgin females. After 3 days, males were stored in liquid nitrogen, and females were allowed to blood-feed and to lay eggs in individual vials. The *Ester* genotype of each father and of each mother was characterized using starch electrophoresis (see below). The Sousse strain was founded with egg-rafts produced by parents (males and females) lacking any overproduced esterase. Bismuth, Yatouch and Mayotte collections were selected with  $1 \text{ mg l}^{-1}$  chlorpyrifos during at least 6 generations, that is, until mortality at  $10 \text{ mg l}^{-1}$  chlorpyrifos was  $\leq 50\%$ . All subsequent selections were mass-performed directly in 1-l tanks.

### Characterization of overproduced esterases, *ace-1* and *ace-2* genes

Overproduced esterases were characterized from thorax homogenates of single adults analyzed on starch gel electrophoresis in Tris-Maleate buffer-EDTA (pH 7.4), as described by Pasteur *et al.* (1988). Esterases were revealed using  $\alpha$ - and  $\beta$ -naphthyl acetates and Fast Garnett (Sigma Aldrich). Allele identification was performed by comparing the electrophoretic mobility of the observed esterases with those from laboratory strains homozygous for the different overproduced enzymes. This was used to control that any overproduced esterases were removed from the Sousse strain.

AChE1 phenotypes encoded by the *ace-1* locus were determined with the témoin-dichlorvos-prpoxur test on head homogenates of single adults (Alout *et al.*, 2009). This test discriminates between phenotype S (that is, homozygotes for the *S* allele), phenotype R or V (homozygotes for the G119S or the F290V mutation, respectively) and phenotypes SR or SV that contain at least one *S* copy and one resistant *R* or *V* copy (for example, *S/R*, *S/V*, *D*, *S/D* or *R/D* or *V/D* genotypes).

The *ace-2* gene was characterized by the PCR test followed by *Hae*III restriction developed by Bourguet *et al.* (1998) to discriminate between the two *C. p. pipiens* and *C. p. quinquefasciatus* subspecies.

### Genetic linkage

Genetic linkage between two loci was measured as the frequency of recombinant genotypes in the backcrossing experiments (that is, the recombination rate). This frequency is expected to be 50% for independent loci, below 50% for linked loci.

## RESULTS

### Inheritance and toxicological properties of HCR

In four field collections from Tunisia (Bismuth and Sousse), Israel (Yatouch) and Mayotte Island (Mayotte), we detected larvae that survived  $1 \text{ mg l}^{-1}$  chlorpyrifos, a dose that kills larvae of the SR strain (homozygous for the *ace-1<sup>R</sup>* allele), thus displaying HCR. We selected strains derived from these field larvae with increasing doses of chlorpyrifos each generation until they displayed  $\leq 50\%$  mortality at  $10 \text{ mg l}^{-1}$ . After selection, all these HCR strains were found homozygous for the *R* allele (Supplementary Table S1).

*A single sex-linked gene is responsible for HCR.* We first analyzed how HCR was inherited by crossing HCR strains to the SR strain, and then by backcrossing the obtained F1 to a parental strain (here SR). Under the hypothesis that resistance in HCR strains as compared with SR is caused by a single gene (named *T*, with a dominant *T* allele in HCR strains and *t* allele in SR), the backcross should contain an equal number of larvae with HCR phenotype (identical to the F1 or *Tt*) and with no HCR phenotype (identical to SR or *tt*). Compared with the SR strain, Sousse displays  $\text{RR}_{50}$  of 2200-fold (Table 1). The F1 progeny displayed a linear chlorpyrifos dose-mortality response (as did the parental strains) and a  $\text{RR}_{50}$  of 530-fold, indicating that HCR is codominant. Note that heterozygous *Tt* insects survived  $1 \text{ mg l}^{-1}$  chlorpyrifos, the dose used to select HCR strains. In contrast to the F1, linearity of the dose-mortality response of the offspring produced by F1 females backcrossed with SR males was rejected ( $P = 0.002$ ). The dose-mortality response disclosed a clear plateau close to 50% mortality (Figure 1), indicating the segregation of two main genotypes (*Tt* as in the F1, and *tt* as in SR) with different resistant properties, as hypothesized.

We also performed the reciprocal backcross to determine whether the *T* gene is linked to sex. Males of each HCR strain (Sousse, Yatouch and Mayotte) were mass-crossed to females SR, and males of their F1 offsprings were backcrossed to females SR (Supplementary Table S2). In *C. pipiens*, sex is determined by a single locus with two alleles (*M* and *m*): males are heterozygous (*Mm*), whereas females are homozygous (*mm*) (Gilchrist and Haldane, 1947). Thus, in HCR

**Table 1** Insecticide dose-mortality responses in *Culex pipiens* strains

Insecticides	Strains or F1 crosses	LC <sub>50</sub> in mg l <sup>-1</sup> (CI)	Slope (s.e.)	RR <sub>50</sub> (CI) <sup>(A)</sup>	RR <sub>50</sub> (CI) <sup>(B)</sup>
Chlorpyrifos-ethyl	Slab	0.00048 (0.00041–0.00054)	10.14 (2.00)	1	—
	HomoVAL	0.0040 (0.0032–0.0049)	2.99 (0.38)	8.4 (6.2–11)	—
	SR	0.0092 (0.0077–0.014)	6.99 (2.66)	19 (13–30)	1
	Sousse	20 (18–24)	3.42 (0.31)	43 000 (27 000–90 000)	2200 (1300–3800)
	Madra	0.0101 (0.0089–0.012)	5.68 (0.90)	21 (12–33)	1.1 (0.66–1.8)
	♀Sousse × ♂SR	4.9 (3.7–6.27)	2.61 (0.41)	10 000 (5800–18 000)	530 (280–990)
	♀Madra × ♂Slab	0.0028 (0.0024–0.0032)	5.71 (0.89)	5.9 (4.0–8.7)	—
	♀Madra × ♂SR	0.0078 (0.0067–0.0095)	4.14 (0.63)	16 (12–22)	0.85 (0.56–1.3)
Chlorpyrifos-methyl	Slab	0.00076 (0.00061–0.0010)	7.54 (2.18)	1	—
	Madra	0.027 (0.019–0.034)	4.28 (0.77)	35 (22–54)	—
Chlorpyrifos(methyl)-oxon	SR	0.020 (0.016–0.26)	2.66 (0.29)	—	1
	Sousse	18.0 (11–60)	1.97 (0.50)	—	890 (310–2600)
Parathion-methyl	Slab	0.0037 (0.0035–0.0039)	8.87 (0.90)	1	—
	Madra	0.0085 (0.0078–0.0094)	4.14 (0.40)	2.3 (1.7–3.0)	—
	SR	0.12 (0.011–0.13)	4.07 (0.38)	32 (19–52)	1
	Sousse	1.58 (1.437–1.77)	4.59 (0.34)	430 (39–4500)	13 (1.2–148)
Paraoxon-methyl	Slab	0.0080 (0.0075–0.0086)	9.85 (1.46)	1	—
	Madra	0.032 (0.025–0.040)	4.10 (0.68)	4.0 (2.4–6.6)	—
	SR	0.83 (0.70–0.97)	8.21 (2.28)	100 (NA)	1
	Sousse	4.18 (3.1–5.4)	3.09 (0.53)	524 (230–1200)	5.0 (NA)
Temephos	Slab	0.0027 (0.0019–0.0036)	6.18 (1.30)	1	—
	Madra	0.0014 (0.0013–0.0025)	6.98 (0.82)	0.54 (0.38–0.76)	—
Propoxur	Slab	0.18 (0.16–0.20)	4.09 (0.46)	1	—
	Madra	0.20 (0.11–0.37)	3.24 (0.83)	1.12 (0.49–2.56)	—
	SR	493.3 (436–559)	8.71 (1.53)	2787 (2208–3519)	—

Abbreviations: CI, 95% confidence interval of the studied parameter; LC<sub>50</sub>=dose inducing a mortality of 50%; NA, not applicable; RR<sub>50</sub>, resistance ratio at LC<sub>50</sub>; s.e., standard error. Bioassays were performed in laboratory strains (Slab, HomoVAL and SR), in strains isolated in this study (Sousse and Madra) and in various F1 crosses (♀Sousse × ♂SR, ♀Madra × ♂Slab and ♀Madra × ♂SR); see text and Figures 1 and 2. The following information is given: slope of the mortality (probit) dose (log) regression and its s.e.; RR<sub>50</sub> using Slab (A) or SR (B) strains as reference. Data's departure from the regression was assessed using the  $\chi^2$  conformity test and was not significant for any bioassay ( $P > 0.05$ ).

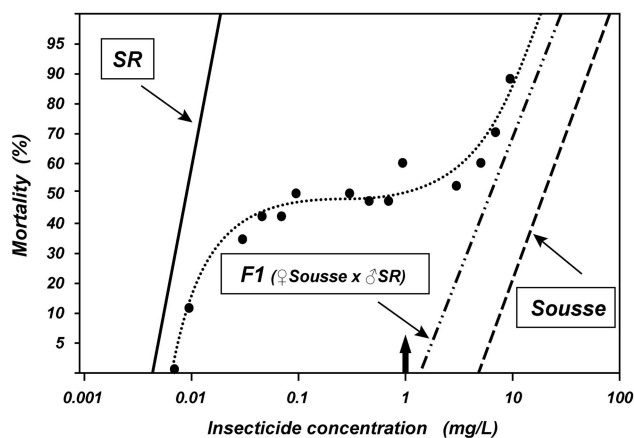

**Figure 1** Chlorpyrifos dose-mortality responses observed in Sousse and SR parental strains, their F1 (♀Sousse × ♂SR) and the offspring of ♀F1 backcrossed to ♂SR. The dotted line represents the expected dose-mortality response of the backcross offspring and black dots the observed mortality. Note that the backcross dose-mortality response shows a clear plateau at 50% mortality, indicating the segregation of two alleles. The arrow indicates 1 mg l<sup>-1</sup> chlorpyrifos, the concentration used to discriminate HCR mosquitoes.

strains, most of males are *MT/mT* and most of females are *mT/mT*, whereas in the SR strain, males are *Mt/mT* and females *mt/mT*. Males of these F1 offsprings were therefore double heterozygous (*MT/mT*), and

they were backcrossed to double homozygous (*mt/mT*) females of the SR strain (Supplementary Table S2). Under the hypothesis of independent assortment between sex and the *T* genes, survivors of a 24-h exposure to 1 mg l<sup>-1</sup> chlorpyrifos (that is, a dose killing all *t/t* genotypes) should contain an equivalent number of males and females. Sex ratios were examined in the offspring of each backcross either in the absence of insecticide or after chlorpyrifos exposure (Table 2). In the absence of insecticide selection (control), sex ratios were not significantly different from the 50% expectation ( $1.01 \geq \chi^2 \geq 1.53$ , 1 d.f.,  $P > 0.2$ ), except for the backcross involving the Sousse strain that displayed a significantly higher frequency of females (57%,  $P < 0.001$ ). In all chlorpyrifos-treated offspring, sex ratios were strongly biased in favor of males (87–91%,  $\chi^2 > 700$ ,  $P < 0.0001$ ). This indicates that the *T* gene is linked to the sex factor in the three strains. The recombination rate between the sex and *T* loci, estimated from the percentage of females among the survivors (as they are all recombinant; Table 2), varied between  $8.7\% \pm 0.8$  and  $12.7\% \pm 0.8$ , with a mean value of  $10.6\% \pm 0.5$  (mean  $\pm$  s.e.).

*HCR is not due to ace-2 gene.* As AChEs are the major targets of OP insecticides such as chlorpyrifos, and because the *ace-2* gene encoding the AChE2 enzyme is linked to the sex factor (Malcolm *et al.*, 1998), we investigated whether the *T* gene could be *ace-2*. This was possible because the HCR strains Sousse and Yatouch belong to the *C. p. pipiens* subspecies, whereas the reference SR strain carries a *C. p. quinquefasciatus* genetic background (Supplementary Table S1). The two subspecies have different *ace-2* alleles (Bourguet *et al.*, 1998), namely *B* in *C. p. pipiens* and *b* in *C. p. quinquefasciatus*. Thus, males



**Table 2 Sex linkage of HCR**

Strain of the heterozygous ♂	Control				Survivors			
	♂	♀	% ♀	$\chi^2$	♂	♀	% ♀	$\chi^2$
Sousse	501	673	57%	25.2***	1374	147	10%	990***
Yatouch	465	428	48%	1.53 <sup>NS</sup>	1052	100	9%	787***
Mayotte	135	152	53%	1.01 <sup>NS</sup>	1500	218	13%	957***
Total	1101	1253	53%	9.81***	3926	465	11%	3560***

Abbreviations: HCR high chlorpyrifos resistance; NS, not significant ( $P > 0.05$ ).

Sex ratio observed among the offspring of ♂*Mt/Mt* from various strains backcrossed to ♀*mt/mt*, in the absence of chlorpyrifos selection (control) or after 24 h of exposures to chlorpyrifos concentrations  $\geq 1 \text{ mg l}^{-1}$ . The  $\chi^2$  tests the sex ratio deviation and has one degree of freedom (significance levels are indicated \* $P < 0.05$ , \*\* $P < 0.01$  and \*\*\* $P < 0.001$ ).

produced in the F1 crosses between males Sousse and females SR are *BMT/bmt*. When backcrossed to SR females (*bmt/bmt*), all females surviving an exposure to  $\geq 1 \text{ mg l}^{-1}$  chlorpyrifos would result from a recombination between sex and *T* loci as seen above. The genotype of these surviving females at the *ace-2* locus can be either heterozygous (*Bb*), indicating that no recombination occurred between the *ace-2* and *T* loci, or homozygous (*bb*) if there was recombination (Supplementary Table S3A). Surviving females derived from the Sousse strain were all *bb* ( $N=21$ ), whereas those derived from the Yatouch strain were *bb* (97%) and *Bb* (3%;  $N=35$ ; Supplementary Table S3B). The difference between the two strains was not statistically significant ( $\chi^2=0.61$ , 1 d.f.,  $P>0.60$ ). Among a total of 56 surviving females, 55 recombined between *T* and *ace-2*, indicating that *ace-2* is distinct from the HCR *T* gene. Furthermore, only one recombinant between the sex and *ace-2* loci (that is, a *Bb* female) was found, showing that sex and *ace-2* loci are much closer to one another than either is to the *T* locus.

**Isolation of a strain with only the *T* allele and no resistant allele at the *ace-1* locus.** The strong linkage between *ace-2* and *T* made it possible to isolate a strain carrying the *T* allele but lacking alleles of other loci associated with chlorpyrifos resistance, in particular the *R* allele at the *ace-1* locus and overproduced esterases. We used the Sousse strain as the source of *T* allele and performed a series of crosses with Slab (Supplementary Table S4) to construct the Madra strain. Initially, all Madra mosquitoes were homozygous for the susceptible *ace-1<sup>S</sup>* allele (*S/S*), the genotypes of males was *Mt/mt* or *Mt/mT* and the genotypes of females was *mt/mt* or *mT/mt*. To increase the frequency of the *T* allele, we hypothesized that it should confer to some extent resistance to chlorpyrifos and selected the Madra strain with increasing doses of chlorpyrifos for at least 12 generations (Supplementary Table S4).

We then analyzed the inheritance of the observed resistance to chlorpyrifos in the Madra strain by crossing Madra females (*T/T*) with Slab males (*t/t*) and the offspring females (*T/t*) were backcrossed to Slab males (*t/t*). The dose-mortality response to chlorpyrifos of the F1 (*T/t*) was linear, and that of the backcross displayed a clear plateau around 50% mortality, confirming that chlorpyrifos resistance in the Madra strain is due to one major gene (*T*) (Figure 2). In the absence of the *R* allele at the *ace-1* locus, the chlorpyrifos resistance conferred by the *T* allele is approximately six-fold in *T/t* heterozygotes and 20-fold in *T/T* homozygotes (Table 1).

**Resistance characteristics of the *T* gene.** The toxicological characteristics associated with the *T* gene was investigated by comparing the resistance with a few insecticides between Madra and Slab strains, both

homozygous *SS* at the *ace-1* locus, and between Sousse and SR, both homozygous *RR* at the *ace-1* locus (Table 1 and Supplementary Table S5). Presence of the synergist DEF (inhibiting some carboxylesterases and glutathione-*S*-transferases) slightly increased chlorpyrifos susceptibility in Madra and Slab, but the synergism ratios in the two strains were not significantly different ( $P \geq 0.95$ ). In presence of PB (inhibiting some cytochrome P450), susceptibility to chlorpyrifos was decreased in Madra and Slab (as expected from the inhibition of cytochrome P450 oxidases that metabolize chlorpyrifos into chlorpyrifos-oxon), but this decrease was not significantly different ( $P \geq 0.95$ ) between the two strains (Supplementary Table S5). The Madra strain was significantly more resistant to chlorpyrifos-methyl compared with Slab ( $RR_{50}=35$ ,  $p < 0.001$ , Table 1) than to chlorpyrifos ( $RR_{50}=21$ ). Thus, although the ethyl moiety of the chlorpyrifos radical may influence the level of resistance, it has no major role in the action of the *T* allele. The resistance to parathion and paraoxon (methyl forms) were also tested in the Madra and Sousse strains (Table 1). As compared with Slab, Madra showed a significant resistance ( $RR_{50}=2.3$  and 4.0, respectively,  $P < 0.001$ ). Similarly, Sousse was more resistant than SR to these two insecticides ( $RR_{50}=13$  and 5, respectively,  $P < 0.001$ ). Although parathion and paraoxon resistances in Sousse are significantly higher than for SR, they are much lower than those recorded for chlorpyrifos (2200-fold vs 13-fold for parathion) or chlorpyrifos-oxon (890-fold vs 5-fold for paraoxon, Table 1). In the presence of temephos, Madra was more susceptible than Slab ( $RR_{50}=0.54$ ,  $P < 0.001$ ). Finally, Madra and Slab strains displayed no significant difference in their dose-mortality responses to propoxur ( $P = 0.43$ ).

In conclusion, chlorpyrifos toxicological data confirmed that, when homozygous, the *T* gene confers the same resistance characteristics in the presence or absence of the synergists DEF and PB in mosquitoes carrying the *S* allele of the *ace-1* gene. Therefore, this indicates that the *T* gene does not code for increased detoxification by carboxylesterases or glutathione-*S*-transferases inhibited by DEF and/or cytochrome P450 oxidases inhibited by PB. In addition, these data show that the *T* allele by itself confers a resistance to chlorpyrifos and to parathion (and to their respective oxidized forms, chlorpyrifos-oxon and paraoxon), but not to temephos or to the carbamate propoxur.

### High synergy between the *T* and *ace-1* genes in HCR

It is classically admitted that, when present in the same individual, two distinct resistance genes may have an additive or a multiplicative effect on resistance (Raymond *et al.*, 1989). We then addressed this issue by comparing  $RR_{50}$  ratios of the Sousse, SR and Madra strains relative to Slab (Table 1). SR (*t/t R/R*) and Madra (*T/T S/S*) showed moderate and similar  $RR_{50}$  ratios for chlorpyrifos relative to Slab (19 and 21, respectively). In *T/t R/R* genotype (F1 offspring of females Sousse  $\times$  males SR) as well as in *T/T R/R* genotype (Sousse strain), the epistatic interaction of the *T* allele with the *R* allele in chlorpyrifos resistance was far higher than expected from the additive hypothesis, and even higher than expected under the multiplicative hypothesis (for example, 10 000-fold observed vs  $\sim 110$ -fold expected in *T/t R/R*, and 43 000-fold observed vs 400-fold expected in *T/T R/R*; Supplementary Table S6). The same situation also stood for parathion (methyl form): the resistance ratio observed in Sousse (*T/T R/R*) is clearly higher than expected under the multiplicative hypothesis (430-fold observed vs  $\sim 74$ -fold expected, respectively). As several resistance alleles (other than *R*) have been selected at the *ace-1* locus in *C. pipiens* populations, the availability of the Madra strain opens the possibility to assess how the presence of the *T* allele would modify the level of resistance conferred by *ace-1* alleles.

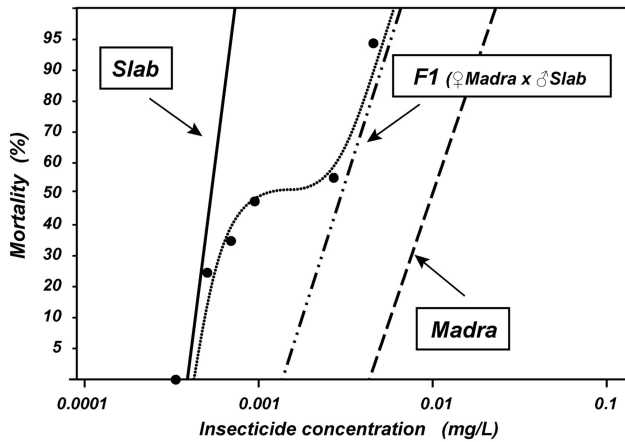

**Figure 2** Chlorpyrifos dose-mortality responses observed in Madra and Slab parental strains, their F1 (♀Madra × ♂Slab) and the offspring of ♀F1 backcrossed to ♂Slab. The dotted line represents the expected dose-mortality response of the backcross offspring and black dots the observed mortality. As in Figure 1, the plateau observed around 50% mortality in the backcross offspring indicates the segregation of two alleles.

*Interaction between the T allele and resistant alleles of the ace-1 gene.* Two main resistant mutations have been selected at the *ace-1* locus in Mediterranean mosquito populations (Alout *et al.*, 2009): the *R* allele carrying the G119S mutation and the *V* allele carrying the F290V mutation. When homozygous in a strain, the *R* allele confers 19-fold and the *V* allele confers 8.4-fold resistance to chlorpyrifos at LC<sub>50</sub>, respectively (Table 1). Duplicated resistant alleles of the *ace-1* gene are currently spreading in *C. pipiens* natural populations and are already present in regions where the resistant *T* allele is present, as in Tunisia (Alout *et al.*, 2011) and in Mayotte (Pocquet *et al.*, 2014). We then analyzed how the *T* allele interacts with three *ace-1* alleles (*R*, *V*, *D*) in different genotypic combinations (Table 3) obtained by crossing the Slab, SR, HomoVAL, Ducos, Madra and Sousse strains. We also analyzed several F2s of the various crosses in order to investigate genotypes that were not available in our strains or in their F1 offspring (see Supplementary Table S7). All analyses are based on the mortality observed 24 h after exposure to 1 mg l<sup>-1</sup> chlorpyrifos. For F2s, observed mortality was compared with expected mortality estimated: (1) by calculating the frequency of each genotype (estimated from Mendelian inheritance of two independent loci) and (2) by taking into account the mortality of each genotype from the study of homozygous strains and their F1 (see Supplementary Information). The observed mortality was in good agreement with the expected one, although slightly higher (Supplementary Table S7). We observed that HCR is expressed in mosquitoes either carrying two *T* alleles (*T/T* homozygotes) and at least one *R* copy (*R/R* homozygotes, *R/S* or *R/V* heterozygotes and likely *R/D*, *D/D*, and *D/S*), or carrying one *T* allele (*T/t* heterozygotes) and two *ace-1*-resistant alleles (*R/R* homozygotes or *R/V* and *R/D* heterozygotes and likely *D/D*). The inability of the *V* allele to produce HCR in *T/T* homozygotes is probably because of the low chlorpyrifos resistance it provides as compared with the *R* allele (see Table 1).

Thus, HCR expression is dependent on the number of resistant alleles at the *T* and *ace-1* loci, as well as on the nature of the resistant allele present at the *ace-1* locus. These results also support that HCR expression requires at least three resistance alleles at the *T* and *ace-1* loci, two at one locus and one at the other.

## DISCUSSION

Using multiple crossing experiments, we evidenced a new and unique gene responsible for the high chlorpyrifos resistance or HCR in several mosquito populations of the *C. pipiens* complex. HCR is observed through a synergistic effect between one allele of this gene and resistant *ace-1* alleles. These results are similar to those obtained on the Gara strain > 15 years ago (Pasteur *et al.*, 1999) and strongly suggest that the HCRs observed in Sousse and Gara are due to the same genetic mechanism. Although we did not perform as many detailed bioassays with Bismuth, Yatouch and Mayotte strains as we did with Sousse, the sex linkage studies also supported the notion that HCR of these strains involves a similar unique gene, named *T*. Thus, the *T* gene has a large geographic distribution and was observed in strains of two subspecies: *C. p. pipiens* from Tunisia and Israel and *C. p. quinquefasciatus* from Mayotte, an island in the Indian Ocean.

Using the linkage observed between the *T* gene and another sex-linked gene (*ace-2*), we constructed the Madra strain, containing the resistant allele at the *T* locus and lacking any other known resistance mechanism (insensitive AChE1 or overproduced esterases). This chlorpyrifos resistance was not affected by DEF or PB synergists. We also showed that, in mosquitoes of the *C. pipiens* complex, HCR is due to positive epistasis between the resistant alleles of the *ace-1* and of the *T* loci. Resistance to chlorpyrifos provided by the *T* gene alone (*T/T* *S/S*, Madra strain) was moderate and equivalent to that of *t/t* *R/R* (*SR* strain) or *T/t* *R/S* one (F1 from Madra × *SR*) genotypes. In contrast, the *T/T* *R/R* genotype (Sousse strain) displayed HCR, with a resistance level far higher than that expected if both genes had multiplicative effects: > 40 000 instead of ~ 400-fold. Investigating the epistasis between the two genes showed that the expression of HCR is controlled by a complex interaction between the number of resistant alleles at each locus and the nature of the mutation present at the *ace-1* gene.

## HCR and *ace-1*-resistant alleles

Interactions between resistance mechanisms were investigated by Raymond *et al.* (1989) using a model of insecticide flow in a larva with four compartments (Figure 3): the outer, the intermediate, the target and the elimination compartments. Let us consider here the target compartment in which the concentration of the toxic insecticide (here chlorpyrifos-oxon) is  $C_T$ . Any mechanism that would decrease  $C_T$  will result in a resistance phenotype. From our bioassays (Table 1), we know that in *t/t* homozygotes (Slab, HomoVAL and *SR* strains), the  $C_T$  able to inhibit AChE1 enzymes is lower for the *S* allele (wild type) than for the *V* allele, and lower for the *V* allele than for the *R* allele. Resistance to chlorpyrifos in *R/S* heterozygotes has been shown to be partially dominant under the same experimental conditions (Bourguet *et al.*, 1996), indicating that the  $C_T$  inhibiting AChE1 molecules is lower in *R/S* than in *R/R* insects. In addition, Labbé *et al.* (2014) showed that chlorpyrifos dose-mortality responses of *D/D* genotypes are similar to those of *R/S* genotypes. From these information, genotypes can be ordered in function of increasing  $C_T$  inhibiting synaptic AChE1:  $S/S < D/S < R/S = D/D < D/R < R/R$  and  $S/S < S/V < V/V < R/V < R/R$ . In *t/t* homozygotes, none of the *ace-1* genotypes displays HCR (Table 3 and Supplementary Table S7), indicating that  $C_T$  is high enough to inhibit all AChE1 molecules present in the synapse when insects are exposed to 1 mg l<sup>-1</sup> chlorpyrifos. In *T/t* heterozygotes, HCR was observed in *R/R*, in *R/D*, likely in *D/D* and to a lesser extent in *R/V* genotypes (Table 3). This indicates that the presence of one *T* allele decreases  $C_T$  enough to allow survival. In *T/T* homozygotes, HCR was observed in *R/S* and likely in *D/S* genotypes, but not in *V/S* or *V/V* genotypes (Table 3).

**Table 3 Chlorpyrifos mortality in various *ace-1* and *T* genotypic combinations**

<i>ace-1</i> locus	<i>T</i> locus	% Mortality	N
SS	<i>tt</i>	100	277
SS	<i>Tt</i>	100	>300
SS	<i>TT</i>	100	268
RS	<i>tt</i>	100	>300
RS	<i>Tt</i>	100	152
RS	<i>TT</i>	5.5	235
RR	<i>tt</i>	100	242
RR	<i>Tt</i>	3.7	219
RR	<i>TT</i>	2.4	296
VS	<i>tt</i>	100 (19)	—
VS	<i>Tt</i>	100	106
VS	<i>TT</i>	100 (19)	—
VV	<i>tt</i>	100	50
VV	<i>Tt</i>	100 (19)	—
VV	<i>TT</i>	100 (20)	—
VR	<i>tt</i>	100 (20)	—
VR	<i>Tt</i>	29.7	145
VR	<i>TT</i>	≤29.7 (20)	—
DD	<i>tt</i>	100	56
DD	<i>Tt</i>	Low (21, 22)	—
DD	<i>TT</i>	Low (21, 22)	—
DS	<i>tt</i>	100 (21)	—
DS	<i>Tt</i>	100	113
DS	<i>TT</i>	Low (22)	—
RD	<i>tt</i>	100 (21)	—
RD	<i>Tt</i>	2.3	133
RD	<i>TT</i>	Low (21)	—

Mortality induced by 24-h exposure to 1 mg l<sup>-1</sup> chlorpyrifos in mosquitoes carrying different genotypic combinations at the *ace-1* and *T* loci. *ace-1* has four alleles (S, R, V and D) and *T* two alleles (*T* and *t*). For each combined genotype tested in a strain or an F1 cross (Supplementary Table S7), the number of studied mosquitoes is indicated (N). For other genotypes, mortality was deduced from the results obtained in F2 crosses (Supplementary Table S7) as explained in the Supplementary Information.

Thus, the decrease of C<sub>T</sub> is higher in the presence of two *T* alleles than in the presence of a single one, indicating that expression of the *T* resistance allele is a critical parameter. However, the decrease of C<sub>T</sub> is not large enough to allow survival of V/V genotypes (or to prevent inhibition of the F290V-AChE1). Ordering *ace-1* genotypes regarding the proportion of the AChE1 variants and their sensitivity to increasing C<sub>T</sub> thus becomes: S/S < S/V < V/V < D/S < R/S < D/D < R/V < R/D < R/R (D/V was not tested). Note that for HCR, genotypes R/S and D/D were not found similar (*T/t* D/D showed HCR whereas *T/t* R/S did not show HCR), whereas chlorpyrifos resistance was similar between R/S and D/D in the absence of the *T* allele (Labbé *et al.*, 2014).

Overall, in larvae exposed to 1 mg l<sup>-1</sup> chlorpyrifos, the decrease of chlorpyrifos-oxon concentration in the synapse (C<sub>T</sub>) due to the presence of two *T* alleles (homozygosity) is large enough to allow survival (HCR) of mosquitoes with at least one copy of the G119S mutation contained in the R or in the D allele (from D/S to R/R in the above sequence), whereas insects with a single copy of the *T* allele (*T/t* heterozygotes) survive only when they carry two *ace-1* resistance alleles (either two R copies like in D/D, D/R and R/R, or one R and one V, like in R/V).

**Mechanisms for decreasing chlorpyrifos-oxon in the target compartment**

Epistasis between the *T* and *ace-1* loci can be explained by three interacting processes: (1) the different inhibition constants of each AChE1 variants, (2) the number of R copies at the *ace-1* locus when one of the allele is duplicated (Labbé *et al.*, 2014) and (3) the ability of the *T* locus to decrease C<sub>T</sub> in the target compartment. This latter process is more efficient in *T/T* than it is in *T/t* genotypes, and is therefore dependent on the number of *T* alleles present in a mosquito (codominance). We also have to consider that C<sub>T</sub> increases with time during insecticide exposure. Taking into account the inhibition constants (k<sub>i</sub>) evaluated by Alout and Weill (2008), the C<sub>T</sub> value inhibiting the AChE1-S enzyme is lower, and thus is reached earlier than the C<sub>T</sub> value inhibiting the AChE1-V enzyme, itself lower and inhibiting earlier than for the AChE1-R enzyme. The longer the time for chlorpyrifos-oxon to reach the C<sub>T</sub> value that inhibits AChE1, the longer the time for the *T* mechanism to metabolize chlorpyrifos-oxon (or/and chlorpyrifos) into an inactive compound.

Diminishing the quantity of chlorpyrifos-oxon available to inhibit AChE1 in the target compartment can be achieved by various mechanisms (Figure 3): (1) decreased penetration of chlorpyrifos inside the body (Figure 3, step (a)), (2) decreased activation of the AChE1-nontoxic chlorpyrifos into its toxic oxon form (step (b)), (3) decreased circulation between the intermediate and target compartments (step (c)) and (4) increased elimination of chlorpyrifos-oxon or chlorpyrifos from the intermediate or/and target compartments to a compartment (respectively steps (d) and (d')) where the pesticide is no longer toxic. However, several mechanisms can be eliminated, such as decreased activation of chlorpyrifos by cytochrome P450 oxidases inhibited by the PB synergist, or increased detoxification by carboxylesterases or glutathione-S-transferases inhibited by DEF. Enhanced elimination of the pesticide can be the result of any process that decreases the pesticide concentration, for example, increased metabolism and increased excretion. These processes were not investigated here, but it must be noted that if they were involved they would have to be specific for certain OPs: the *T* gene does not provide resistance to temephos (this study and Ben Cheikh *et al.*, 1998) and pyrimifos (Pasteur *et al.*, 1999), but was shown to induce resistance to chlorpyrifos and parathion. Among proteins potentially

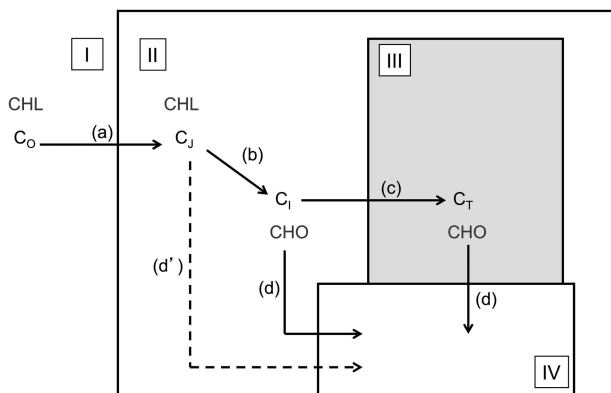

**Figure 3** Compartment model of insecticide flow in a larva (modified from Raymond *et al.*, 1989). (I) Outer compartment, where the concentration of chlorpyrifos is C<sub>0</sub>; (II) intermediate compartment within the larvae, where the concentration of chlorpyrifos is C<sub>j</sub> and that of chlorpyrifos-oxon C<sub>1</sub>; (III) target site compartment, where the concentration of chlorpyrifos-oxon is C<sub>T</sub>; (IV) compartment where the insecticide is no longer toxic. (a), (c) and (d) correspond to constants k<sub>1</sub>, k<sub>2</sub> and k<sub>3</sub> described by Raymond *et al.* (1989), (b) is the constant of transformation of chlorpyrifos to chlorpyrifos-oxon and (d') the elimination of chlorpyrifos before it becomes toxic. These constants represent the rate of each transformation. CHL, chlorpyrifos; CHO, chlorpyrifos-oxon.



implicated in this mechanism are (1) arylesterases (or A-esterases) that are not inhibited by DEF (Aldridge, 1953) and known to be involved in paraoxon and chlorpyrifos degradation (see below) and (2) cytochrome P450 oxidases, as some of them are not inhibited by PB (Feyereisen, 1999). However, a major hurdle to narrow the list of candidate proteins remains the partial assembly of the *C. pipiens* genome that prevents taking advantage of the observed linkage disequilibrium of *T* with *ace-2*.

Paraoxonases (named as PONs for their ability to degrade paraoxon) may represent interesting candidates, although arthropods genomes, including insects, do not contain orthologs to vertebrate PONs (Estin *et al.*, 2010). However, PONs were also shown to be lactonases, enzymes that metabolize endogenous and exogenous lactones, ubiquitously found in nature. PON activity against OPs is thought to be promiscuous and to have arisen during their evolution. PONs belong to the class of A-esterases described by Aldridge (1953) and were shown later to degrade chlorpyrifos-oxon at a much higher rate than paraoxon. PONs are not inhibited by OP or DEF, and are also able to detoxify the nerve agents sarin and soman. Because PONs are not inhibited by OPs, they are able to hydrolyze them in much larger quantity than carboxylesterases, ~1000 times more in humans (see Billecke *et al.*, 2000; Harel *et al.*, 2004; Draganov, 2010; Elias and Tawfik, 2012).

Another mechanism could involve the ATP-binding cassette (ABC) transporters such as the P-glycoproteins that transport toxic substances outside the cell, thus reducing their intracellular concentration. P-glycoproteins have been associated with resistance to cancer therapy drugs, conferring a multi-drug resistance phenotype when over-produced (Wang *et al.*, 1995). ABC transporters have been shown to participate in insecticide resistance in various species, including mosquitoes (Porretta *et al.*, 2008; Gahan *et al.*, 2010; Bariami *et al.*, 2012). ABC transporter mRNAs were also found overexpressed in *Plutella xylostella* strains resistant to chlorpyrifos (You *et al.*, 2013). However, inhibition of some ABC transporters had no effect on *C. pipiens* mortality exposed to chlorpyrifos (Buss *et al.*, 2002). Even if HCR relies on activity of an ABC transporter, it may prove difficult to identify a candidate, as ABC transporter families are made of 52 members in *Anopheles gambiae* (Dermauw and Van Leeuwen, 2014) and 70 in *C. pipiens* members.

## CONCLUSION

In this study, we have shown that high chlorpyrifos resistance (HCR) observed in several *C. pipiens* populations collected worldwide requires a particular combination of allelic variants of *ace-1*, the major target of OPs and carbamates, and of an unknown *T* gene, linked to the sex factor and *ace-2*. By crossing various strains, we evidenced that *ace-1* and *T* act in strong synergy, as they elicit a resistance level 100 higher than expected from a simple multiplicative effect. This strongly suggests that the *T* gene has the capacity to reduce the concentration of chlorpyrifos in the synapse. We were able to anticipate the synergy of the *T* allele with other *ace-1* alleles, in particular the duplicated alleles, which are currently spreading in natural populations (Labbé *et al.*, 2014). Finally, the availability of the Madra strain opens a way to test whether the *T* allele may influence resistance to other insecticide classes, and constitutes a biological material suitable for identifying the *T* gene by differential transcriptomic analysis.

## DATA ARCHIVING

Bioassay data available from the Dryad Digital Repository: <http://dx.doi.org/10.5061/dryad.vv46k>.

## CONFLICT OF INTEREST

The authors declare no conflict of interest.

## ACKNOWLEDGEMENTS

We are very grateful to Sandra Unal and Raja Ben Cheikh for technical assistance and to Ariel Herold and Nicolas Pocquet for providing the Israel and Mayotte strains, respectively. This work was funded by ANR Morevol Santé-Environnement, ANR SilentAdapt (Ministère délégué à la Recherche) and by the Comité de Coopération Marseille-Provence-Méditerranée supervised by Robert Bismuth. Contribution 2015.187 of the Institut des Sciences de l'Evolution de Montpellier (UMR CNRS-UM2 5554).

- Aldridge WN (1953). Serum esterases I. *Biochem J* **53**: 110–117.
- Alout H, Labbé P, Berthomieu A, Pasteur N, Weill M (2009). Multiple duplications of the rare *ace-1* mutation F290V in *Culex pipiens* natural populations. *Insect Biochem Mol Biol* **39**: 884–891.
- Alout H, Labbé P, Pasteur N, Weill M (2011). High incidence of *ace-1* duplicated haplotypes in resistant *Culex pipiens* mosquitoes from Algeria. *Insect Biochem Mol Biol* **41**: 29–35.
- Alout H, Weill M (2008). Amino-acid substitutions in acetylcholinesterase 1 involved in insecticide resistance in mosquitoes. *Chem Biol Interact* **175**: 138–141.
- Alout H, Berthomieu A, Hadjivassiliou A, Weill M (2007). A new amino-acid substitution in acetylcholinesterase 1 confers insecticide resistance to *Culex pipiens* mosquitoes from Cyprus. *Insect Biochem Mol Biol* **37**: 41–47.
- Bariami V, Jones CM, Poupartin R, Vontas J, Ranson H (2012). Gene amplification, ABC transporters and cytochrome P450s: unravelling the molecular basis of pyrethroid resistance in the dengue vector, *Aedes aegypti*. *PLoS Negl Trop Dis* **6**: e1692.
- Ben Cheikh H, Ben Ali-Haouas Z, Marquine M, Pasteur N (1998). Resistance to organophosphorus and pyrethroid insecticides in *Culex pipiens* (Diptera: Culicidae) from Tunisia. *J Med Entomol* **35**: 251–260.
- Berticat C, Boquien G, Raymond M, Chevillon C (2002). Insecticide resistance genes induce a mating competition cost in *Culex pipiens* mosquitoes. *Genet Res* **79**: 41–47.
- Billecke S, Draganov D, Counsell R, Stetson P, Watson C, Hsu C *et al.* (2000). Human serum paraoxonase (PON1) isozymes Q and R hydrolyze lactones and cyclic carbonate esters. *Drug Metab Dispos* **28**: 1335–1342.
- Bourguet D, Fonseca D, Vourch G, Dubois MP, Chandre F, Severini C *et al.* (1998). The acetylcholinesterase gene *Ace*: a diagnostic marker for the *pipiens* and *quinquefasciatus* forms of the *Culex pipiens* complex. *J Amer Mosq Control Assoc* **14**: 390–396.
- Bourguet D, Prout M, Raymond M (1996). Dominance of insecticide resistance presents a plastic response. *Genetics* **143**: 407–416.
- Buss DS, McCaffery AR, Callaghan A (2002). Evidence for p-glycoprotein modification of insecticide toxicity in mosquitoes of the *Culex pipiens* complex. *Med Vet Entomol* **16**: 218–222.
- Dermauw W, Van Leeuwen T (2014). The ABC gene family in arthropods: comparative genomics and role in insecticide transport and resistance. *Insect Biochem Mol Biol* **45**: 89–110.
- Draganov DI (2010). Lactonases with organophosphatase activity: structural and evolutionary perspectives. *Chem Biol Interact* **187**: 370–372.
- Duron O, Labbé P, Berticat C, Rousset F, Guillot S, Raymond M *et al.* (2006). High *Wolbachia* density correlates with cost of infection for insecticide resistant *Culex pipiens* mosquitoes. *Evolution* **60**: 303–314.
- Elias M, Tawfik DS (2012). Divergence and convergence in enzyme evolution: parallel evolution of paraoxonases from quorum-quenching lactonases. *J Biol Chem* **287**: 11–20.
- Estin ML, Stoltz DA, Zabner J (2010). Paraoxonase 1, quorum sensing, and *P. aeruginosa* infection: a novel model. *Adv Exp Med Biol* **660**: 183–193.
- Feyereisen R (1999). Insect P450 enzymes. *Annu Rev Entomol* **44**: 507–533.
- Gahan LJ, Pauchet Y, Vogel H, Heckel DG (2010). An ABC transporter mutation is correlated with insect resistance to *Bacillus thuringiensis* Cry1Ac toxin. *PLoS Genet* **6**: e1001248.
- Georghiou GP, Metcalf RL, Giddens FE (1966). Carbamate-resistance in mosquitoes: selection of *Culex pipiens fatigans* Wied (= *Culex quinquefasciatus*) for resistance to Baygon. *Bull World Health Organ* **35**: 691–708.
- Gilchrist BM, Haldane JBS (1947). Sex linkage and sex determination in a mosquito, *Culex molestus*. *Heredity* **33**: 175–189.
- Harrel M, Aharoni A, Gaidukov L, Brumshstein B, Khersonsky O, Meged R *et al.* (2004). Structure and evolution of serum paraoxonase family of detoxifying and anti-sclerotic enzymes. *Nature Struct Mol Biol* **11**: 412–419.
- Labbé P, Milesi P, Yébakima A, Pasteur N, Weill M, Lenormand T (2014). Gene-dosage effects on fitness in recent adaptive duplications: *ace-1* in the mosquito *Culex pipiens*. *Evolution* **68**: 2092–2101.
- Labbé P, Berthomieu A, Berticat C, Alout H, Raymond M, Lenormand T *et al.* (2007). Independent duplications of the acetylcholinesterase gene conferring insecticide resistance in the mosquito *Culex pipiens*. *Mol Biol Evol* **24**: 1056–1067.



- Labbé P, Alout H, Djogbénu L, Pasteur N, Weill M. (2011). Evolution of resistance to insecticide in disease vectors. In: Tibayrenc M (ed). *Genetics and Evolution on Infectious Diseases*. Elsevier Publishing Compagny: London, UK, pp 363–409.
- Malcolm CA, Bourguet D, Ascolillo A, Rooker SJ, Garvey CF, Hall LMC *et al*. (1998). A sex-linked *Ace* gene, not linked to insensitive acetylcholinesterase-mediated insecticide resistance in *Culex pipiens*. *Insect Mol Biol* **7**: 107–120.
- Milesi P, Pocquet N, Labbé P (2013). BioRssay: a R script for bioassay analyses. Available at: <http://www.isem.univ-montp2.fr/recherche/equipes/genomique-de-ladaptation/personnel/labbe-pierrick/>.
- Pasteur N, Pasteur G, Catalan, Bonhomme F, Britton-Davidian J (1988). *Practical Isozyme Genetics*. Ellis Horwood Ltd: Chichester, England.
- Pasteur N, Marquine M, Ben Cheikh H, Bernard C, Bourguet D (1999). A new mechanism conferring unprecedented high resistance to Chlorpyrifos in *Culex pipiens* (Diptera: Culicidae). *J Med Entomol* **36**: 794–802.
- Pocquet N, Darriet F, Zumbo B, Milesi P, Thiria J, Bernard V *et al*. (2014). Insecticide resistance in disease vectors from Mayotte: an opportunity for integrated vector management. *Parasit Vectors* **7**: 299.
- Porretta D, Gargani M, Medici A, Punelli F, Urbanelli S (2008). Defence mechanisms against insecticides temephos and diflubenzuron in the mosquito *Aedes caspius*: the P-glycoprotein efflux pumps. *Med Vet Entomol* **22**: 48–54.
- Raymond M, Heckel DJ, Scott JG (1989). Interactions between pesticide genes: model and experiment. *Genetics* **123**: 543–551.
- Wang SJ, Scavetta R, Lenz HJ, Danenberg K, Danenberg PV, Schonthal AH (1995). Gene amplification and multidrug resistance induced by the phosphatase-inhibitory tumour promoter okadaic acid. *Carcinogenesis* **16**: 637–641.
- Weill M, Lutfalla G, Mogensen K, Chandre F, Berthomieu A, Berticat C *et al*. (2003). Insecticide resistance in mosquito vectors. *Nature* **423**: 423–426.
- You MS, Yue Z, He WY, Yang XH, Yang G, Xie M *et al*. (2013). A heterozygous moth genome provides insights into herbivory and detoxification. *Nat Genet* **45**: 220–225.

Supplementary Information accompanies this paper on Heredity website (<http://www.nature.com/hdy>)