



HAL
open science

Automation of a creep-testing machine for research activities

Baptiste Trajin, Yannick Balcaen, Joël Alexis

► **To cite this version:**

Baptiste Trajin, Yannick Balcaen, Joël Alexis. Automation of a creep-testing machine for research activities. International Conference on Research and Education in Mechatronics (REM), Jun 2018, Delft, Netherlands. pp.0. hal-01944240

HAL Id: hal-01944240

<https://hal.science/hal-01944240>

Submitted on 4 Dec 2018

HAL is a multi-disciplinary open access archive for the deposit and dissemination of scientific research documents, whether they are published or not. The documents may come from teaching and research institutions in France or abroad, or from public or private research centers.

L'archive ouverte pluridisciplinaire **HAL**, est destinée au dépôt et à la diffusion de documents scientifiques de niveau recherche, publiés ou non, émanant des établissements d'enseignement et de recherche français ou étrangers, des laboratoires publics ou privés.



Open Archive Toulouse Archive Ouverte

OATAO is an open access repository that collects the work of Toulouse researchers and makes it freely available over the web where possible

This is an author's version published in: <http://oatao.univ-toulouse.fr/20008>

To cite this version:

Trajin, Baptiste^{[ORCID](#)} and Balcaen, Yannick^{[ORCID](#)} and Alexis, Joël^{[ORCID](#)}
Automation of a creep-testing machine for research activities.
(2018) In: International Conference on Research and Education in Mechatronics (REM), 7 June 2018 - 8 June 2018 (Delft, Netherlands).

Any correspondence concerning this service should be sent to the repository administrator: tech-oatao@listes-diff.inp-toulouse.fr

Automation of a Creep-testing Machine for Research Activities

TRAJIN Baptiste

Laboratoire Génie de Production (LGP)
Université de Toulouse, INP-ENIT
Tarbes, France
baptiste.trajin@enit.fr

BALCAEN Yannick

Laboratoire Génie de Production (LGP)
Université de Toulouse, INP-ENIT
Tarbes, France
yannick.balcaen@enit.fr

ALEXIS Joël

Laboratoire Génie de Production (LGP)
Université de Toulouse, INP-ENIT
Tarbes, France
joel.alexis@enit.fr

Abstract—This paper deals with automation of a creep-testing machine mainly dedicated to research activities. The requirements linked to the machine were established by the material science researchers. These requirements were then addressed to mechatronic researchers and teachers. In order to enhance the link between research activities and training in the engineering school linked to the research laboratory, students projects of Master degree driven by researchers were proposed. These projects were totally multi-disciplinary, mobilizing knowledge acquired by students during their cursus in the school. Several items were developed by students: automation, mechanics, power electronics and real-time programming.

Index Terms—Creep-testing machine, Programmable Logic Controller, Power Electronics, Real-time Programming

I. INTRODUCTION

The National Engineering School of Tarbes (ENIT) is a 5 years post-graduate school, delivering engineer and master diploma. This school trains generalist engineers with specializations in the Master degree level: industrial engineering, mechanical engineering, material science, civil engineering and integrated mechatronic systems. During the first semester of the first year of master degree, students must achieve a scientific project linked to industrial or research activities. This project represents 64 hours of work during the semester for every student. The aims of these projects are to allow students to mobilize their knowledge acquired during the whole cursus on a project supervised by researchers and teachers. Obviously, one of the teaching challenges of these projects is to learn students to find information by their own through a bibliographic study. This paper presents two projects and their results mixing material science, automation and mechatronic activities, perfectly in line with the multidisciplinary university courses of students.

The final goal of these two projects is the full automation of a creep-testing machine. Creep is a time-dependent deformation under a stress still below the yield strength of a material at high temperature. Deformations increase in time at a constant load. The first research work on this phenomenon dates back to the end of the 19th century [1]. They were led to understand catastrophic breaks of parts in service. Creep testing is valuable for determining time dependant deformation of materials at a given temperature under constant load. So it allows to determine the parameters of the power law for primary

creep, secondary creep rate and time to rupture. This is important when dimensional control is crucial so components can be safely designed for high temperature service such as in aero turbojet engines or nuclear energy plants. The creep temperature of a metal depends on their melting point with a creep temperature of 40% of melting temperature [2], [3].

A low cost creep-testing machine has been developed in the research laboratory associated with ENIT and is presented in section II. Due to the low amount of working hours dedicated to student projects, the automation of the creep-testing machine in section III has been divided into two different projects. The first project in section III-A was led by 2 students and concentrated on the supervision and control of the system. The second project in section III-B, taken place after the first one was led by 3 students and concerned the mechatronic drives included in the creep-testing machine. Section IV gives a conclusion about the results and the students experience during these projects.

II. CREEP-TESTING MACHINE

A. Description of the machine

Creep-testing machines already exists in commerce. These machines allow creep of materials under stress and high temperature. The definition of high temperature depends on the fusion temperature of the material under test. As an example, creep of lead appears at ambient temperature. As a contrary, creep of Nickel based super-alloys becomes sensitive above 900 K.

Research activities conducted in the laboratory should be able to ensure creep of Nickel based super-alloys with applied loads of several hundreds of Newton. Consequently, existing machines in commerce are of high cost. A real effort has been done in the laboratory to design and build a low cost creep-testing machine, mainly using existing elementary parts in commerce. As shown in figure 1, the design of the machine is relatively simple. A maximum load of 25 kN should be applied to the test piece. Consequently, a system of levers and pulley is designed to apply a high load on the test piece using few and light weights. The load is applied to the test piece using a chain lead on a wheel at the end of the leverage system. This design ensures that the load is only

applied to the main axis of the test piece.

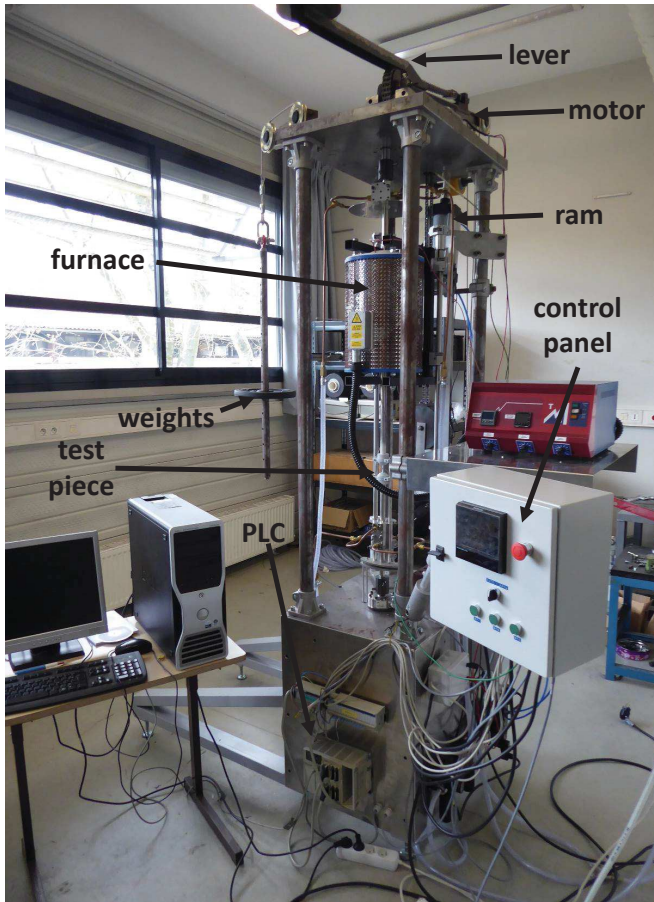

Figure 1. Creep-testing machine.

Load and displacement probes are used to precisely measure creep of the test piece. On the one hand, the knowledge of displacement allows to estimate the strain of the test piece. On the other hand, measuring the load allows to deduce the stress on the test piece. Moreover, several thermocouples are placed along the test piece to measure local temperature and estimate thermal gradients.

B. Scientific requirements

Other requirements were added by researchers in material sciences. Figure 2 shows a generic creep curve of alloys [4].

A first requirement specified by material science researcher was to be able to measure elongation due to load applied at ambient temperature and elongation due to heat elevation. This requirement has an impact on the schedule of the machine's operation. This also induces that the load and the heat should be slowly and regularly applied to the test piece.

The second requirement was to protect the fracture surfaces after the rupture of the test piece from oxidation in order to clearly observe these surfaces. This means that the heat should be stopped rapidly after the rupture of the test piece.

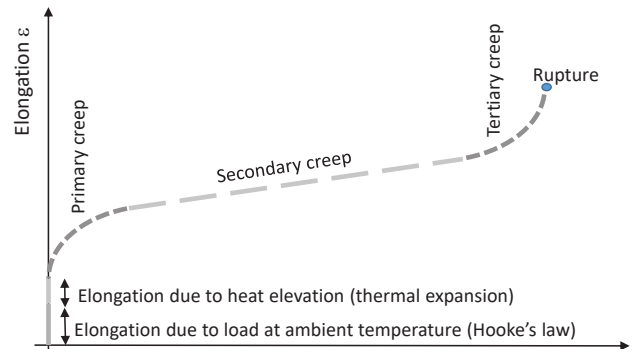

Figure 2. General creep curve of a material.

Finally, the third requirement was to have a completely secure creep-testing machine. This induces a real-time survey of the parameters of the machine and the test piece such as the temperature or the rupture.

III. STUDENT PROJECTS

A. Automation of the creep-testing machine

From the requirements expressed by the materials science researchers, a first project was proposed to a team of 2 students of Master degree. This project concerned the high level automation of the creep-testing machine: functional analysis of the system and the programming of the Programmable Logic Controller (PLC).

1) *Functional analysis:* The project was totally carried out by the students. After some meetings with material science researchers, it was decided to build a functional analysis using G.E.M.M.A which is a graphic tool dating back to 1981. It allows to represent work and stop modes of automated production systems [5]. G.E.M.M.A of the creep-testing machine is given in figure 3. It can be seen that some operations cannot be automated and must be realized by the operator of the machine. This particular point was validated in accordance with project supervisors and materials science researchers.

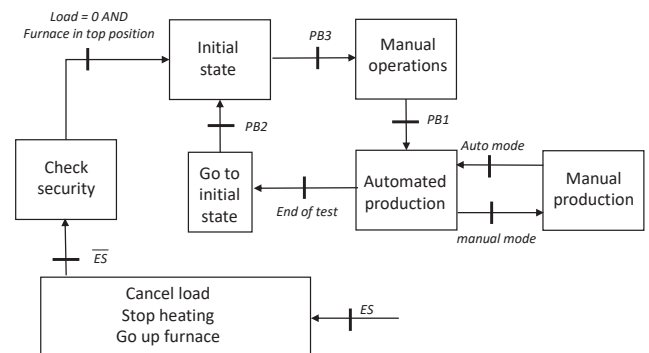

Figure 3. G.E.M.M.A of the creep-testing machine.

Moreover, the conducted analysis help to define necessary controls of the machine:

- *ES* is the emergency stop button,
- *PB1*, *PB2* and *PB3* are push buttons,
- *auto/manu mode* is a three state selector.

G.E.M.M.A indicates that the load applied to the test piece must be controlled. In order to realize this function, students proposed to use a pneumatic ram acting on the leverage to gently apply and cancel the load on the test piece. First ram position cancels the load on the test piece by supporting the weights and the second ram position frees the leverage to apply the load.

Furthermore, the *End of test* condition in the G.E.M.M.A is the combination of two elementary conditions: rupture of the test piece or end of the given test period.

G.E.M.M.A analysis also gives a solution to the requirement concerning the protection of fracture surfaces at the end of the test procedure. In order to rapidly stop heating, the power supply of the furnace is cut off when the rupture of the test piece is detected. Moreover, the furnace is moved from the heating position, face to the test piece, to a position far over the test piece. This induces that a motor and associated converter with position sensors must be chosen or designed to move the furnace at the beginning and the end of the test.

The functional analysis also helps to define acquisition systems to measure parameters and variables of the machine. Parameters such as push buttons, selectors, emergency stop buttons, position sensors of the motor will be measured through the PLC. Variables of the system such as temperature, load, and displacement will be measured by a dedicated acquisition system that should be able to communicate easily with the PLC. A *Graphtec MT100* is chosen by the students with the agreements of supervisors. *MT100* acquisition system allows to synchronously acquire 10 differential inputs. One input is dedicated to the signal measurement from the load sensor, two other inputs are for the signals from displacement sensors. Free inputs are for temperature sensors. Moreover, *MT100* is able to be programmed through input values and is also able to generate alarm signals depending on the input values. This specific functions are used to communicate with the PLC in a bang-band way. As an example, when the rupture of the test piece occurs, the measured load becomes null or negative. Using a threshold on this value, an alarm is generated on an output of *MT100* directly connected to an input of the PLC.

2) Equipments for automation of the creep-testing machine:

As described before, functional analysis leads to the choice of equipments for monitoring and piloting the creep-testing machine. The student project also defined bonds between the different equipments as depicted in figure 4. In this graphic, simple arrows represent signal links and double arrows represent power link (pneumatic or electric). At this stage, motor and motor controller were not defined in this project. The 24V DC and 12V DC energy are produced by

two in stock AC-DC power supplies. The need of a 12V DC is justified by the use of electromechanical valves in stock. The adaptation between the two electrical networks is realized using electromechanical relays, ensuring isolations between the two power supplies. Push buttons, emergency stop and selector are supplied by the PLC in 24V DC. It is clear in figure 4 that the PLC is the supervisory element of the whole automated system.

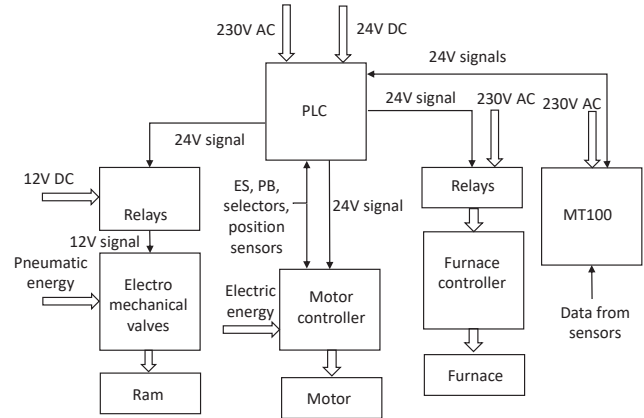

Figure 4. Bonds between equipments for the creep-testing machine.

3) *Programming the PLC*: The advantage of using G.E.M.M.A for the functional analysis is that it directly implies the programming of the PLC. The chosen PLC is a *TSX Micro 3722* one. Using their knowledge, students decided to program the PLC with Sequential Function Chart (SFC) and Ladder Language [6]. Four different and complementary SFC were designed and implemented into the PLC: a security SFC, a main SFC, a normal production SFC and a return SFC.

The aim of the security SFC is to manage actions when the emergency stop occurs. At emergency stop, the furnace is switched off and it comes back to its top position. Moreover, mechanical load is canceled on the test piece using the pneumatic ram.

The main SFC manages actions done at the beginning of testing, before the normal production. It allows to launch the normal production SFC which is dedicated to the testing procedure itself. The return SFC is the last part of the procedure, happening at the end of the testing to get back the machine in its initial state.

The difficulty lies in that these SFC include human operations done at the beginning of the procedure. Two ways of programming are considered. On the one hand, some operations are considered as finished when the operator validates the action using a push button. On the other hand, other operations are considered as finished after a given duration in automatic mode or using a validation with a push button in manual mode. Previous durations are specified in accordance with materials science researchers who will use the creep-testing machine.

Figures 5 and 6 depict the different SFC of the whole system. Duration of acquisition is measured using internal timers. As this duration is long (about 250 hours), the time base (i.e.

the precision) of the timer is set to 1 minute. Although the program is relatively simple, a watch dog set to 100 *ms* is added in the program to avoid long time loop.

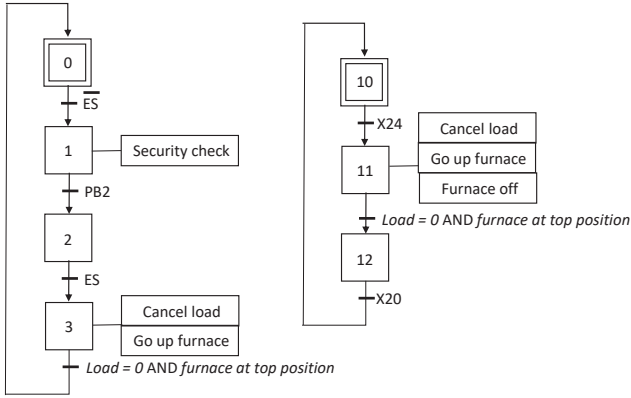

Figure 5. Security (left) and return (right) SFC.

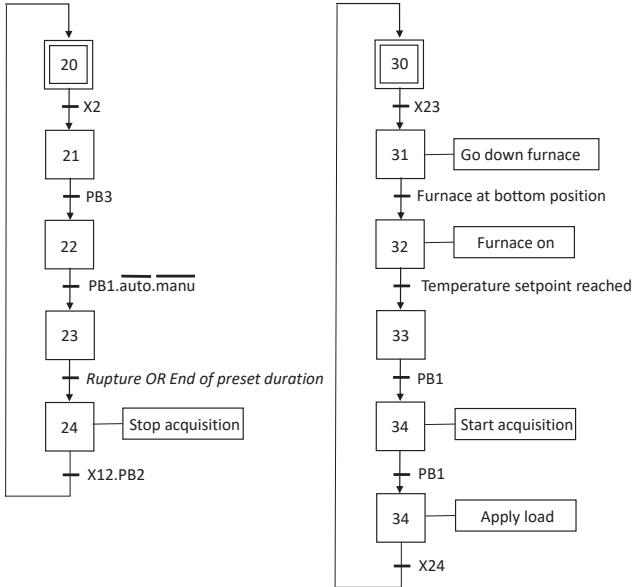

Figure 6. Main (left) and normal production (right) SFC.

This step forms deliverables of the first student project. In addition, a requirement document has been established for the motor and its controller. Despite theoretical knowledge about G.E.M.M.A and SFC, students developed their ability to analyse and program a real case with a client and with associated difficulties such as modification of requirements during the project.

B. Motor and associated controller

Considering the knowledge of students about DC motor, structure of converters and programming of micro-controllers, a second project for the furnace's motor and its controller has been proposed to a team of 3 master degree students. The aim

of this second project was to define an adapted motor, design and realize the associated power converter and program the controller.

1) *Choice of the motor*: Considering the available power supply of 24V DC, a permanent magnet DC motor of 24V nominal voltage has been chosen. This motor directly drives a worm drive. This system ensures a mechanical speed reduction between the motor axis and the speed of the furnace. Moreover, mechanical irreversibility between the furnace and the motor is provided by the worm drive. This implies that it is not necessary to supply the motor to maintain the furnace's position. Furthermore, the mechanical frictions introduced by the worm drive avoid to consider electromechanical braking. The mechanical design of the creep-testing machine includes a counterweight equivalent to the weight of the furnace to prevent from mechanical imbalance. Consequently, the current consumption of the DC motor is mainly due to frictions in the system. It is then obvious that this current consumption will be close to the no-load current, i.e. about 1A.

Considering characteristics equations of a DC motor in (1) [7], and neglecting internal resistance of the motor R and friction torque Γ_f , it can be supposed that the speed of the furnace will be linearly dependent on the supply voltage U of the motor.

$$\begin{cases} \Omega = \frac{U - RI}{K_\phi} \\ I = \frac{\Gamma_f + \Gamma_l}{K_\phi} \end{cases} \quad (1)$$

with:

- Ω the rotating speed of the motor in $rad.s^{-1}$,
- U the supply voltage in V ,
- R the internal resistance of the motor in Ω ,
- I the motor current in A ,
- K_ϕ the electromechanical coupling coefficient of the motor,
- Γ_f and Γ_l the friction and loss torques respectively in $N.m$.

2) *Power converter*: Regarding the nominal rotating speed of the motor, it becomes necessary to reduce the supply voltage of the motor to avoid high linear speed of the furnace. Moreover, as there is no braking system, it is also necessary to reduce the speed of the furnace when approaching the stroke end positions. Consequently, the DC motor is supplied through a power converter to vary the speed of the furnace.

Considering the available 24V DC power supply and the nominal voltage of the motor, also considering that the power supply is a voltage source and the motor is a current source through its inductance, students decided to realize a DC-DC buck converter. As the motor should turn clockwise and anti-clockwise to ensure rise and descent of the furnace, a full-bridge structure is chosen for the buck converter as shown in figure 7 [8].

Two main criteria were considered to define the power switches: static characteristics and power losses. Regarding static characteristics, power switches could be MOSFET or IGBT and anti-parallel diode. Theoretically, anti-parallel diode is not necessary when using MOSFET due to their

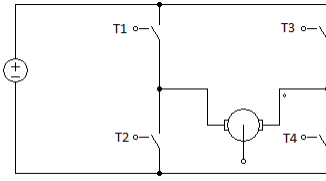

Figure 7. Structure of the buck converter.

body diode [9]. However, the body diode of a MOSFET is generally of low quality: high reverse recovery time and charge. Consequently, an anti-parallel diode is often added to a MOSFET.

For conduction power losses of MOSFET, only forward resistance has to be considered. As a contrary, for IGBT, forward resistance and threshold voltage take part in conduction losses (2) [10].

$$\begin{cases} P_{cond,igbt} = v_{ce,sat} \alpha I_{load} + R_{ce,on} \alpha I_{load}^2 \\ P_{cond,mos} = R_{ds,on} \alpha I_{load}^2 \end{cases} \quad (2)$$

with:

- P_{cond} the conduction losses,
- R_{on} the forward resistances,
- I_{load} the RMS load current,
- α the duty cycle,
- $v_{ce,sat}$ the threshold IGBT voltage.

Considering averaged current of about 1A and voltage of 24V, and considering datasheets of IGBT and MOSFET for this range of voltage and current, it becomes clear that MOSFET with antiparallel diode are the most suitable semi-conductors to be used in the buck converter due to their lower conduction losses. Moreover, switching losses in IGBT are generally higher than in MOSFET due to turn-off time.

After choosing power switches, students project focussed on drivers. This point is totally new for the students. IR2113 high and low side drivers are totally adapted to control half bridge. The use of high side driver function leads to study a boot-strap circuit for the supply of the high side MOSFET gate. The boot-strap capacitor value is calculated regarding the gate input capacitor C_{iss} and the gate control resistor. The drawback of the classical boot-strap circuit is the limitation of the duty cycle for the up switch. Indeed, boot-strap capacitor delivers necessary current to turn-on the up switch. After the switching, a leakage current tends to empty the capacitor. The boot-strap capacitor is charging again when the up switch is off. Consequently, the maximum value of the duty cycle is limited. This limitation depends on the leakage current, the capacitor and gate resistor values and the available current to charge the boot-strap capacitor. Finally, some calculus demonstrate that the duty cycle will be limited to 90%.

In order to speed up the MOSFET turn-off, a fast diode and a resistor are added in antiparallel of the gate control resistor. Finally, to generate a local gate control voltage of 12V, a linear voltage regulator is used. The current delivered by this

regulator corresponds to the supply of the driver and to the charge of the boot-strap capacitor.

Regarding power losses of switches, driver and linear voltage regulator, and also the operation time of the buck converter (movement of the furnace should last about 30s), it is considered that natural convection will be sufficient to avoid high temperature of components and no radiator are placed on the buck converter. The schematic of a half-bridge buck converter with driver is given in figure 8.

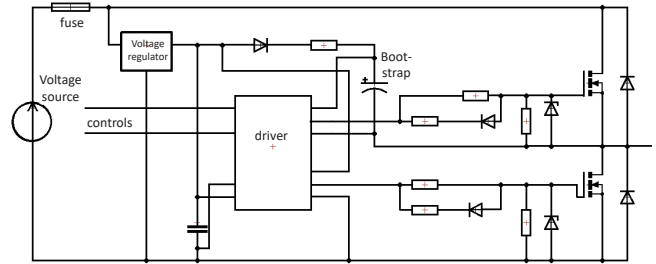

Figure 8. Schematic of the half-bridge buck converter.

Despite their lack of knowledge in electronic, students designed and realized the buck converter using their knowledge in electricity, bibliography and the advice of supervisor.

3) *Control of the buck converter:* The last step of the project was to control the buck converter using micro-controller. The easiest way, decided between students and supervisors, is to use an *Arduino Mega 2560* development board. The amount of inputs and outputs and the computation capabilities of this development board are sufficient to manage the motor. Moreover, the development of applications is facilitated by an automatic configuration of timers, registers, analog to digital converters...

First of all, the switching strategy of the four MOSFET has been designed according to the motor requirements. As an example, only the clockwise rotation of the motor is described. Two strategies could be studied. The first one is to control in opposition $T1$ and $T2$, to maintain $T3$ opened and to control $T4$ in the same way as $T1$ (see figure 7). However, this strategy implies to program dead time between the switching of $T1$ and $T2$. This lead to a more complex program. The second strategy is more simple: only switch $T1$ is controlled, $T2$ and $T3$ are maintained opened and $T4$ is maintained closed. This strategy avoids to program dead time due to natural switching of antiparallel diode of MOSFET $T2$. Figure 9 clearly shows, depending on control of the four MOSFET that the whole motor current passes through $T4$, increasing current through $T1$ and decreasing current through antiparallel diode of MOSFET $T2$. Note that when the motor is stopped, $T1$ and $T3$ and maintained opened and $T2$ and $T4$ are maintained closed to ensure the charge of boot-strap capacitors. A dead time of 10ms is inserted between stop state and rotation state to avoid short circuit of the supply voltage source.

According to the requirements expressed by material science researchers, the speed of the furnace should change along the

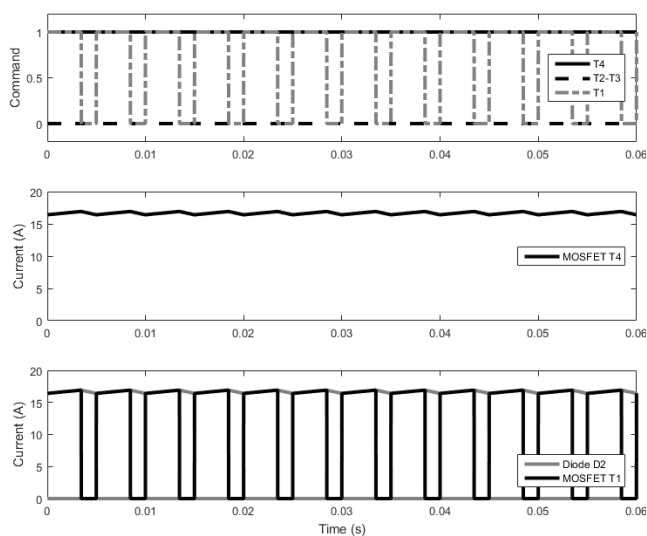

Figure 9. Currents in the buck converter depending on switching strategy.

stroke: the first and last 10% of the stroke should be at low speed and the other 80% of the stroke should be at high speed. It induces modification of duty cycle during the stroke and the adding of position sensors during the stroke in addition to end stroke sensors. To detect the state change of these sensors whose signals are transmitted to the *Arduino* board, the best way of programming is to manage real-time interruptions in the micro-controller using switch-case programming. However, regarding time constants of the system, for simplicity, a sequential programming is considered. It is based on the same principle as SFC and corresponding algorithm is given in figure 10. As there is no watch dog in *Arduino*, using sequential programming implies to write a simplest and lightest code as possible to ensure that state change of sensors will be clearly and always detected.

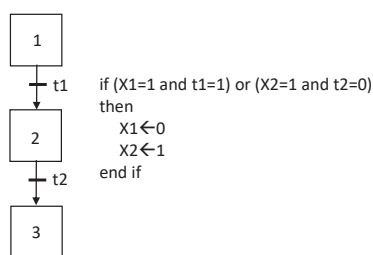

Figure 10. Algorithm of sequential programming.

Finally, in order to connect sensors supplied with 24V DC to *Arduino* board whose inputs are 0 – 5V, optocouplers are used to isolate sensors and *Arduino*. The same principle is applied between *Arduino* PWM outputs and driver's inputs.

IV. CONCLUSIONS

This paper presented the automation of a creep-testing machine used for material science researches. The design of

the machine was done by the material science researchers. The automation of the machine was entrusted to Master degree students of the ENIT through team projects, supervised by mechatronic researchers. The two groups worked on the machine, the first one about the high level automation and the supervision of the system and the second one about the motor and its controller to move the furnace used in the machine. Students mobilized their general knowledge in mechatronic (automation, DC motor, power converter, programming) and completed them with bibliographic study in order to apply on a real system. These projects, realized almost in autonomy, have resulted in a fully automated creep-testing machine and the satisfaction of the clients of the projects, i.e. materials science researchers. The machine is now used in research studies on several materials such as titanium alloys and soon on Nickel-based super-alloys.

ACKNOWLEDGMENT

The authors want to thank José Guimaraes, technician, who designed and built all electronic boards during the different projects.

The authors also want to thank the students involved in the different projects: Quentin Sudour, Guillaume Irribarren, Vincent Rebardeau, Nicolas Lacaze and François Beytout.

REFERENCES

- [1] E. N. da C. Andrade, "On the viscous flow of metals, and allied phenomena," Proc. R. Soc. Lond., A, LXXXIV, 1910, pp.1–12.
- [2] M. F. Ashby, D. R. H. Jones, Engineering Materials 1 - An Introduction to Properties, Applications and Design, 4th ed., Oxford: Butterworth-Heinemann, 2012.
- [3] H. Altenbach, Topical problems and applications of creep theory, International Applied Mechanics, vol. 39, no. 6, 2003.
- [4] T. H. Courtney, Mechanical behavior of materials, New-York: McGraw-Hill, 1990.
- [5] S. Moreno, E. Peulot, Le GEMMA : modes de marches et d'arrêts, GRAFCET de coordination des tâches, conception des systèmes automatisés de production sûrs, 2nd ed., Paris: Casteilla, 2009.
- [6] IEC 61131-3:2013, Programmable controllers - Part 3: Programming languages, International Electrotechnical Commission standard, 2013.
- [7] A. Hughes, B. Drury, Electric motors and drives: fundamentals, types and applications, 4th ed., Oxford: Elsevier, 2013.
- [8] W. Shepherd, L. Zhang, Power converter circuits, New-York: Marcel Dekker, 2004.
- [9] R. S. Ramshaw, Power electronics semiconductor switches, 2nd ed., London: Chapman and Hall, 1993.
- [10] B. Trajin, P. E. Vidal, J. Viven, "Electro-thermal model of an integrated buck converter," 17th European Conference on Power Electronics and Applications (EPE'15 ECCE-Europe), 2015.
- [11] I. Lee, J. Y. T. Leung, S. H. Son, Handbook of Real-Time and Embedded Systems, London: Chapman and Hall, 2007.