



HAL
open science

Dimension Reduction for Shape Optimization

David Gaudrie, Rodolphe Le Riche, Victor Picheny, Benoît Enaux, Vincent Herbert

► **To cite this version:**

David Gaudrie, Rodolphe Le Riche, Victor Picheny, Benoît Enaux, Vincent Herbert. Dimension Reduction for Shape Optimization. Journées de la Chaire Oquaido 2018, Nov 2018, Cadarache, France. hal-01934569

HAL Id: hal-01934569

<https://hal.science/hal-01934569v1>

Submitted on 26 Nov 2018

HAL is a multi-disciplinary open access archive for the deposit and dissemination of scientific research documents, whether they are published or not. The documents may come from teaching and research institutions in France or abroad, or from public or private research centers.

L'archive ouverte pluridisciplinaire **HAL**, est destinée au dépôt et à la diffusion de documents scientifiques de niveau recherche, publiés ou non, émanant des établissements d'enseignement et de recherche français ou étrangers, des laboratoires publics ou privés.

Dimension Reduction for Shape Optimization

David Gaudrie^{1,2}, Rodolphe le Riche^{2,3}, Victor Picheny⁴, Benoît Enaux¹, Vincent Herbert¹
¹Groupe PSA, ²Mines Saint-Étienne, ³CNRS LIMOS, ⁴Prowler.io

Context and past work

Multi-objective optimization of high dimensional systems

$$\min_{\mathbf{x} \in X \subset \mathbb{R}^d} (f_1(\mathbf{x}), \dots, f_m(\mathbf{x}))$$

Very tiny budget (≈ 100 - 200 evaluations), many objectives ($m \approx 6$ - 8) \Rightarrow impossible for classical MO-EGO approaches to uncover the Pareto Front (growing size of \mathcal{P}_Y with m)

\Rightarrow Target well-chosen parts of \mathcal{P}_Y [1]

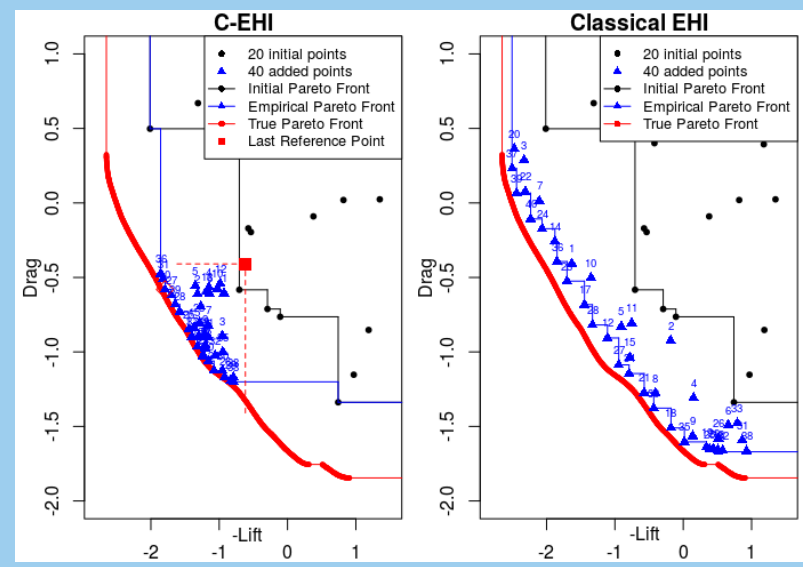

But what when d is large ($\gtrsim 50$)?

CAD parameters and shapes

- $\mathbf{x} \in \mathbb{R}^d$ design parameters

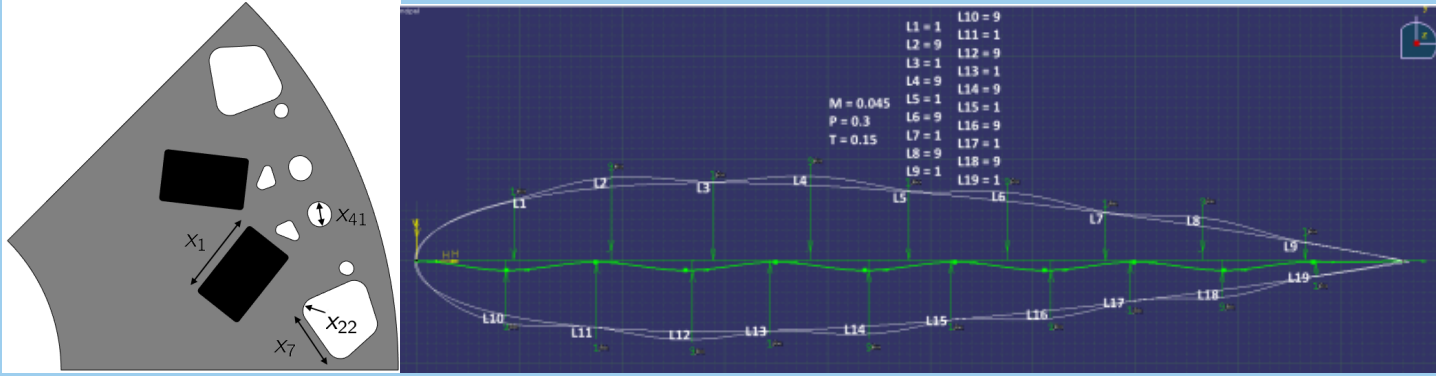

- Associated shapes $\Omega_{\mathbf{x}}$ approximately live in a $\delta < d$ dimensional space

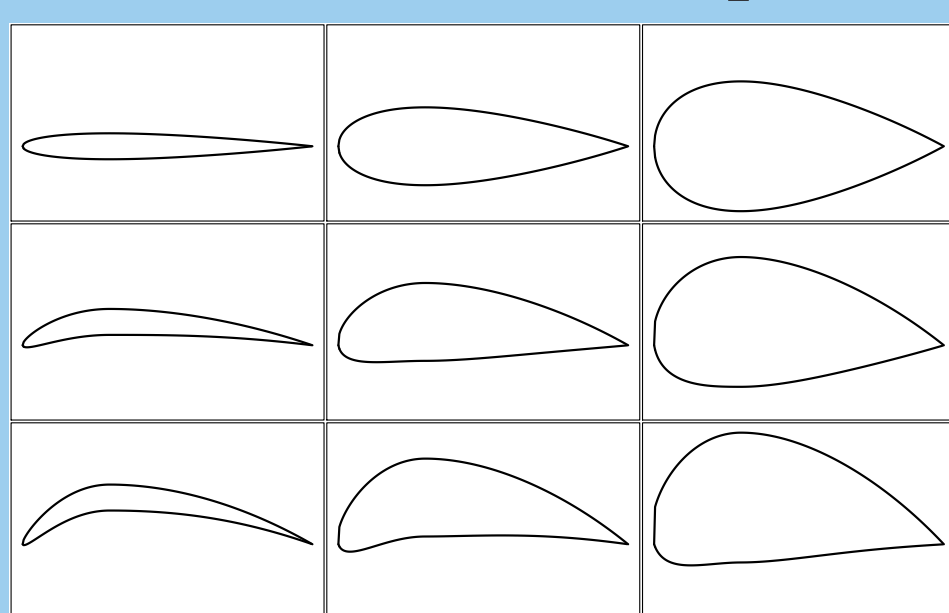

- Computation time of $\Omega_{\mathbf{x}}$ and $\phi(\mathbf{x})$ negligible compared to evaluation of $\mathbf{f}(\mathbf{x})$

High-dimensional mapping

- Analyze many possible shapes $\Omega := \{\Omega_{\mathbf{x}}, \mathbf{x} \in X\}$ in a high-dimensional space $\Phi \subset \mathbb{R}^D$, $d \ll D$
- Retrieve the δ dimensional manifold embedded in \mathbb{R}^D
- Build the kriging surrogates and perform the optimization in this manifold

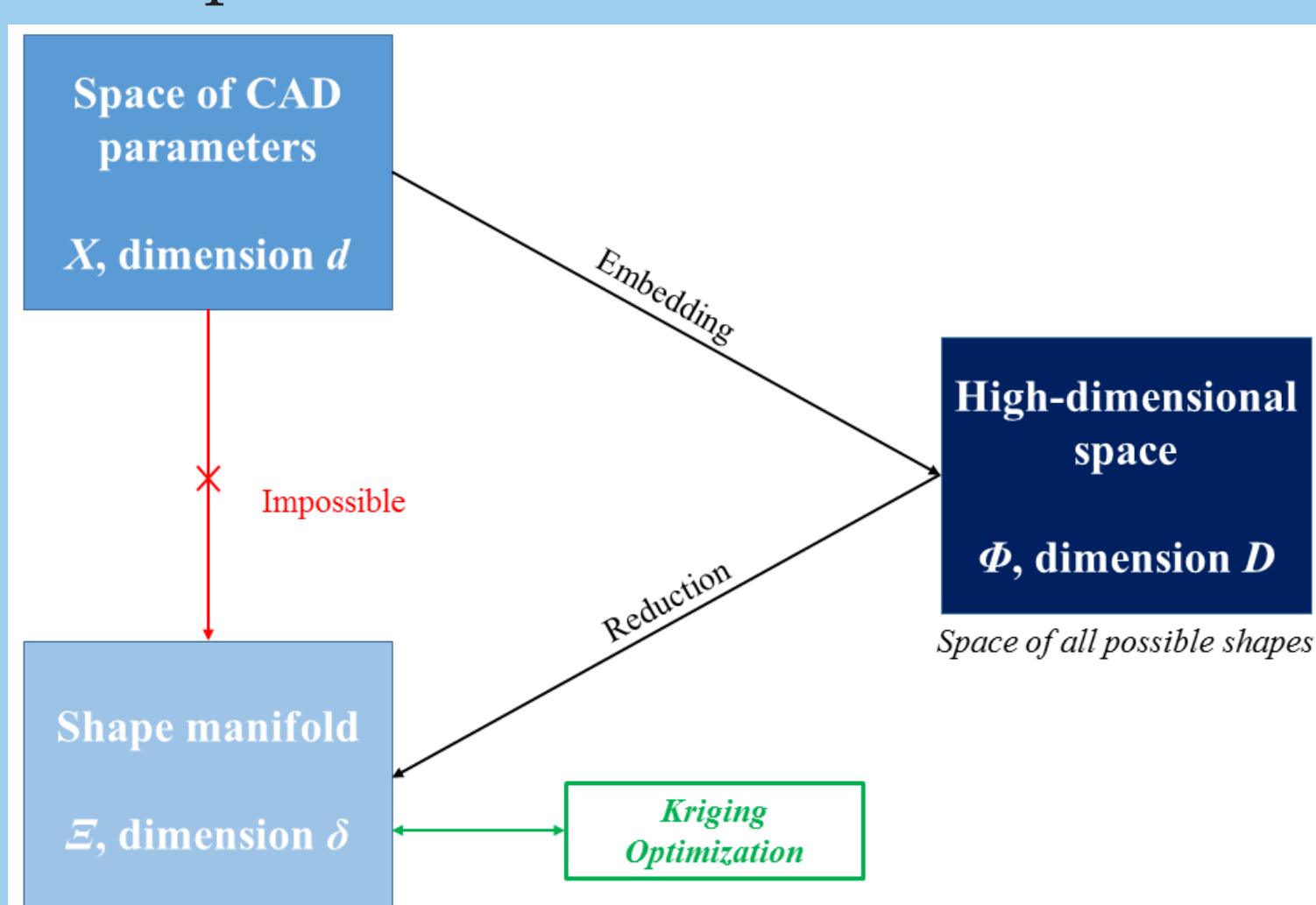

High dimensional representation of $\Omega_{\mathbf{x}}$

$$\phi: X \rightarrow \Phi$$

$$\mathbf{x} \mapsto \phi(\mathbf{x})$$

- Characteristic function $\chi_{\Omega_{\mathbf{x}}}$
- Signed distance to $\partial\Omega_{\mathbf{x}}$
- Discretization of $\partial\Omega_{\mathbf{x}}$

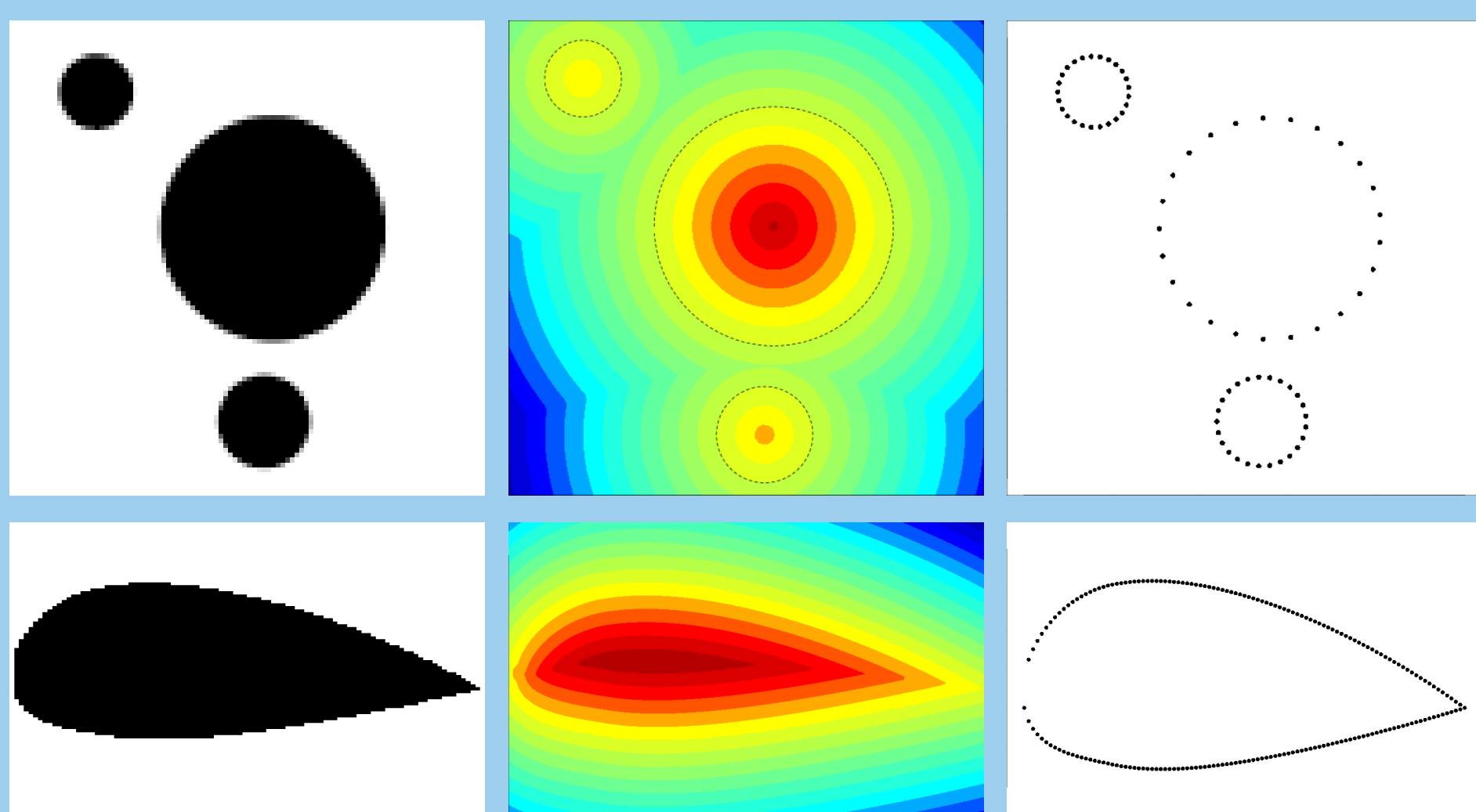

Choice of mapping ϕ is critical for identifying Ξ

Reduction by PCA in shape space

Following the work of [2, 3, 4]

- Draw N designs $\mathbf{x}^{(i)} \in X$ and compute $\Phi := (\phi(\mathbf{x}^{(i)}))_{i=1, \dots, N}$
- Analyze the variety of shapes by applying a PCA on Φ : the eigenvectors of $\Phi^T \Phi$, \mathbf{v}^j form a shape basis, $\Phi^{(i)} = \bar{\Phi} + \sum_{j=1}^D \alpha_j^{(i)} \mathbf{v}^j$
- Instead of $\mathbf{x}^{(i)}$, work with its eigenbasis coordinates: $\alpha^{(i)} := (\alpha_1^{(i)}, \dots, \alpha_D^{(i)})^T$
- $\alpha^{(i)}$, $i = 1, \dots, N$ form a δ -dimensional manifold

Tests cases

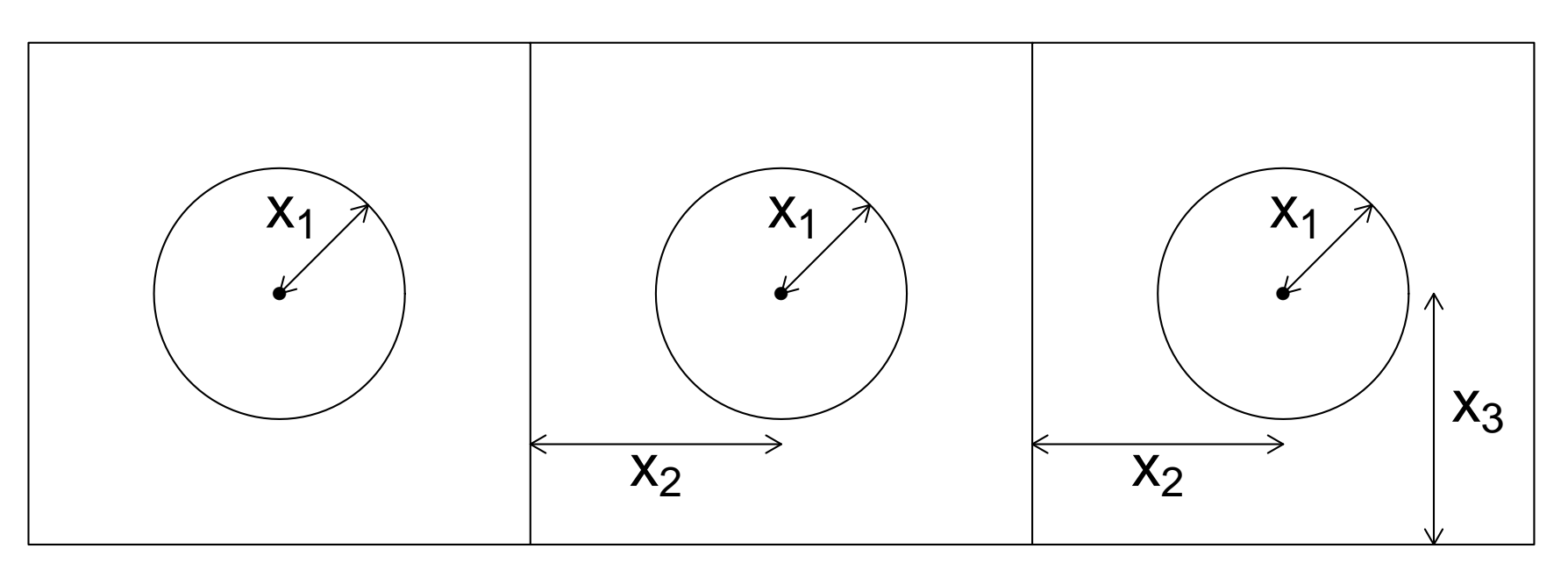

Characteristic function

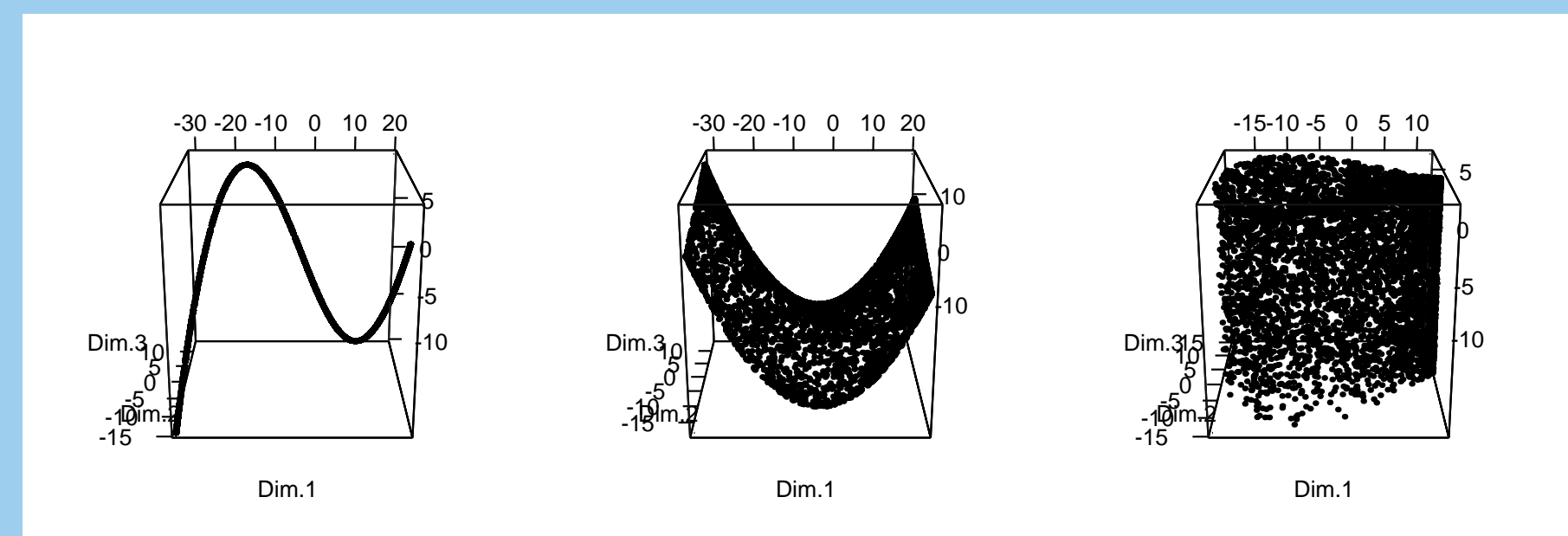

Signed distance

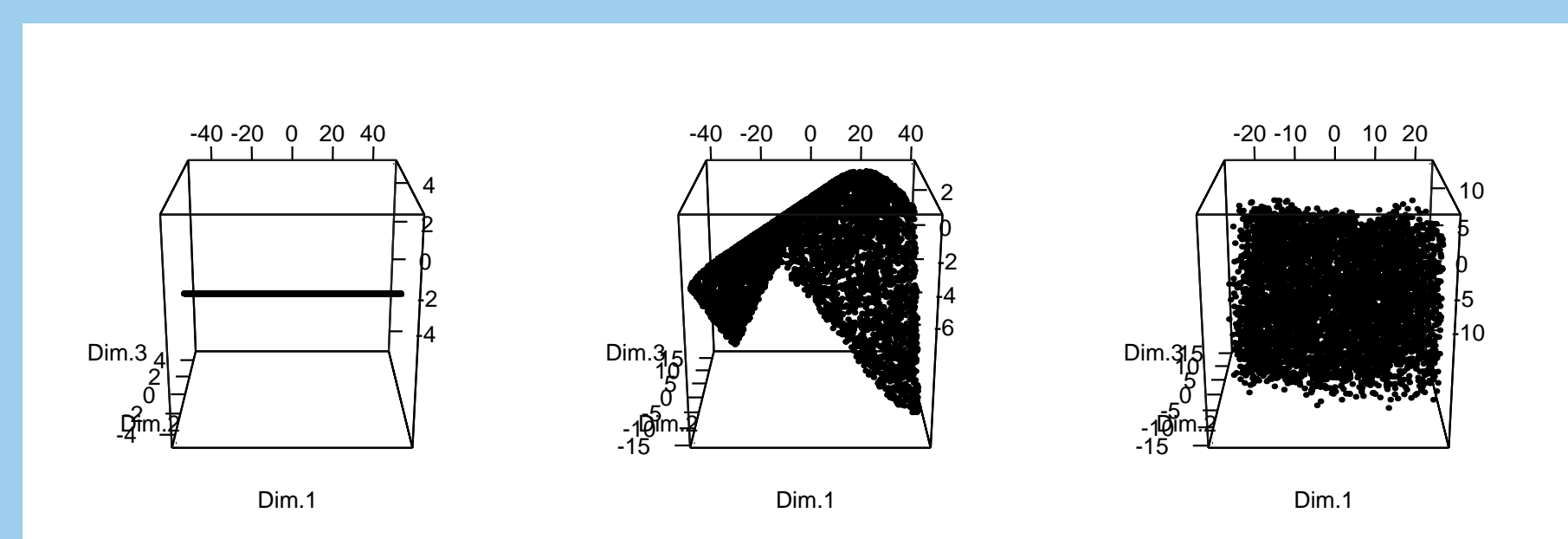

Discretization

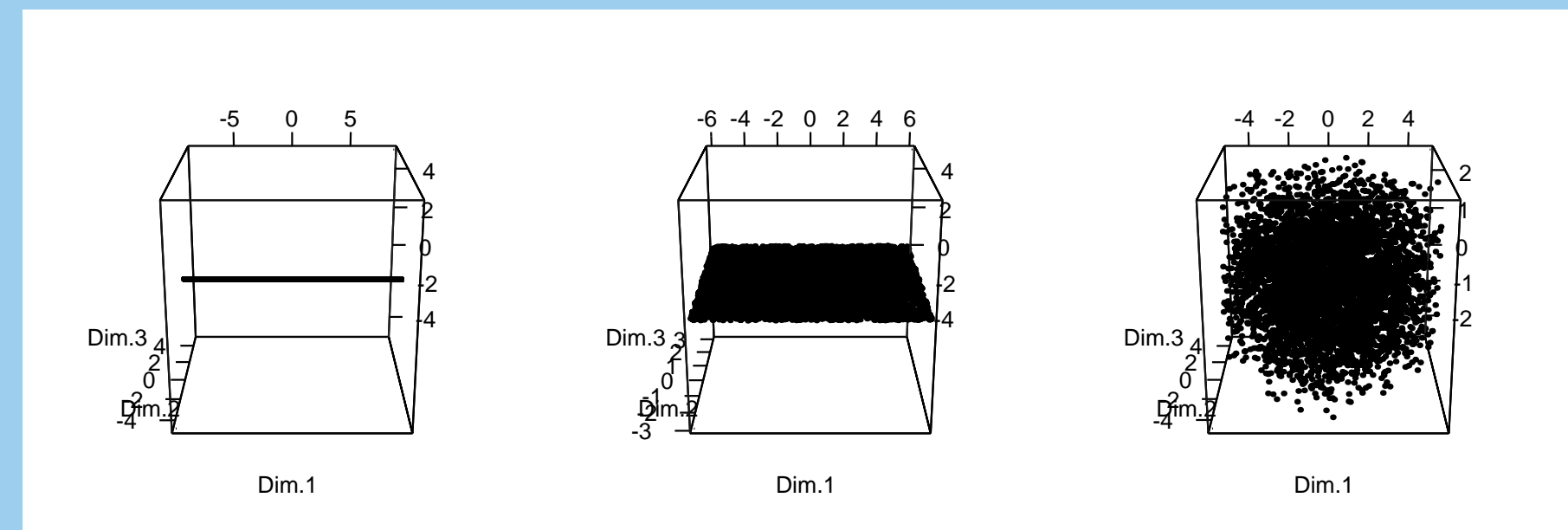

- Dimension reduction: $\Phi^{(i)}$ approximated by retaining δ principal components from their eigenvalue contribution

$$\Phi^{(i)} \approx \bar{\Phi} + \sum_{j=1}^{\delta} \alpha_j^{(i)} \mathbf{v}^j$$

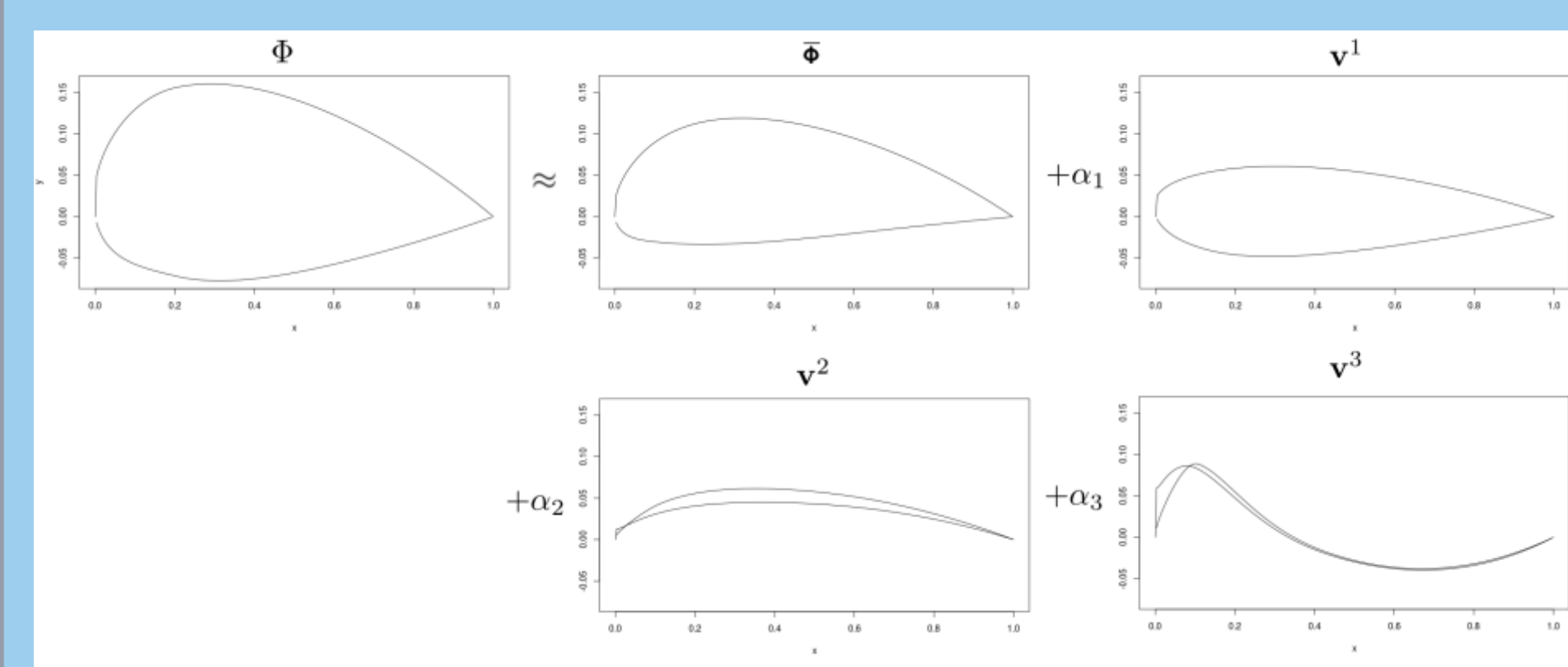

References

- D. Gaudrie, R. Le Riche, V. Picheny, B. Enaux and V. Herbert, Budgeted Multi-Objective Optimization with a Focus on the Central Part of the Pareto Front - Extended Version, arXiv preprint 1809.10482 (2018).
- C. Goodall, Procrustes methods in the statistical analysis of shape, Journal of the Royal Statistical Society, Series B (Methodological), 285-339 (1991).
- M. Stegmann and D. Gomez, A brief introduction to statistical shape analysis, Informatics and mathematical modelling, Technical University of Denmark, DTU, 15(11), 2002.
- B. Raghavan, G. Le Quilliec, P. Breikopf, A. Rassineux, J. M. Roelandt and P. Villon, Numerical assessment of springback for the deep drawing process by level set interpolation using shape manifolds, International journal of material forming, 7(4), 487-501 (2014).

Kriging in reduced basis

- ϕ = shape discretization: most efficient mapping to retrieve δ

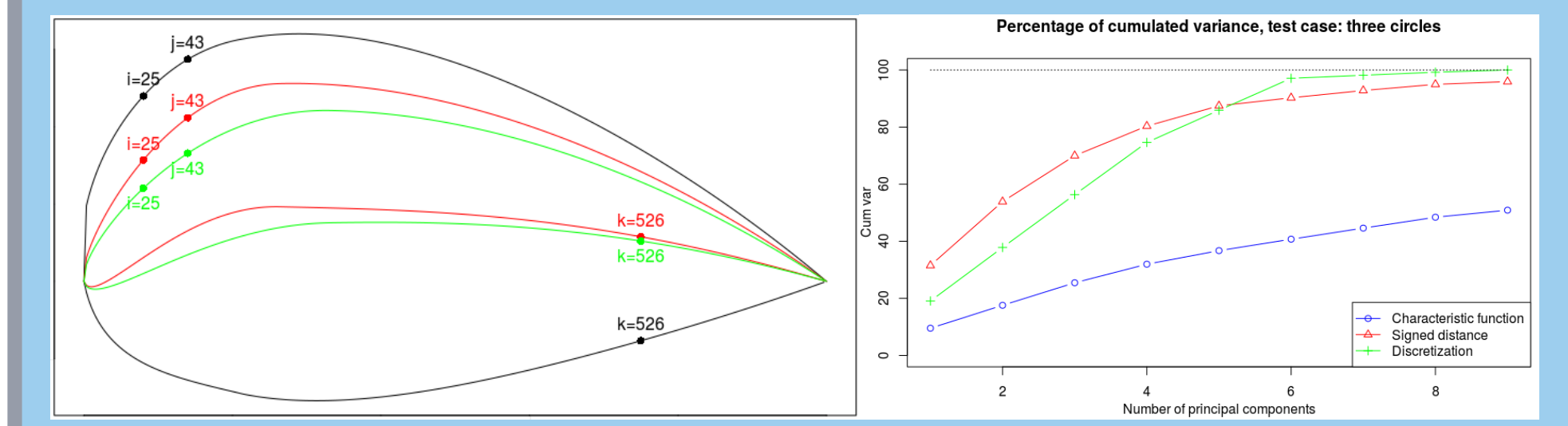

- Principal axis: eigenshapes

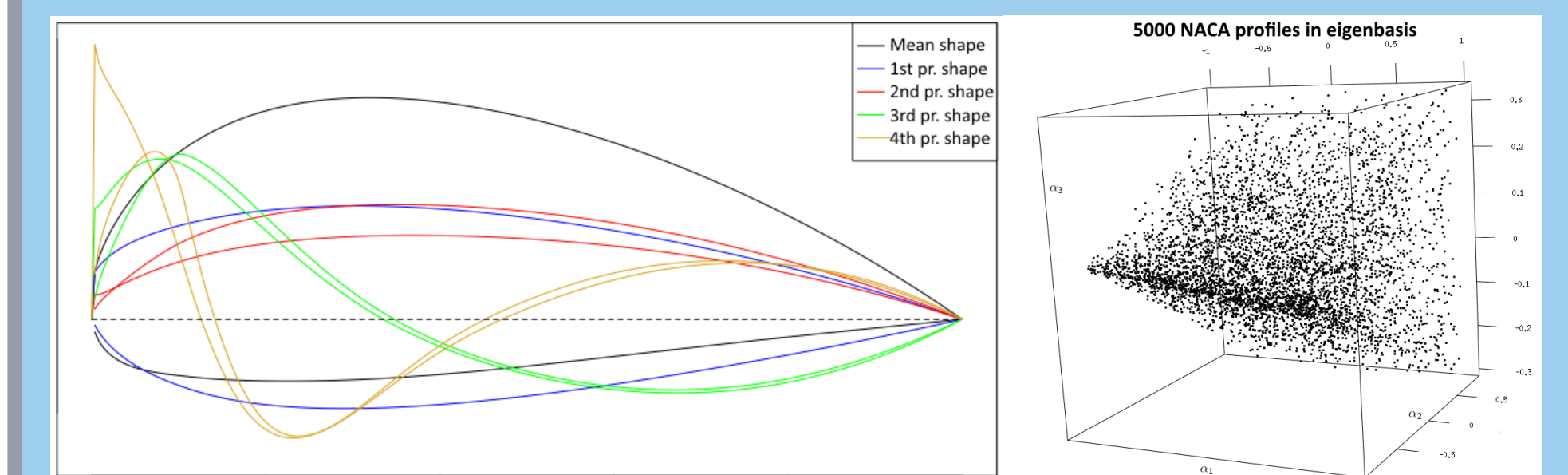

Kriging on principal components: test cases

- (a) Over-parameterized circle, $\mathbf{x} \in \mathbb{R}^{39}$
 $\rightarrow \delta = 3$

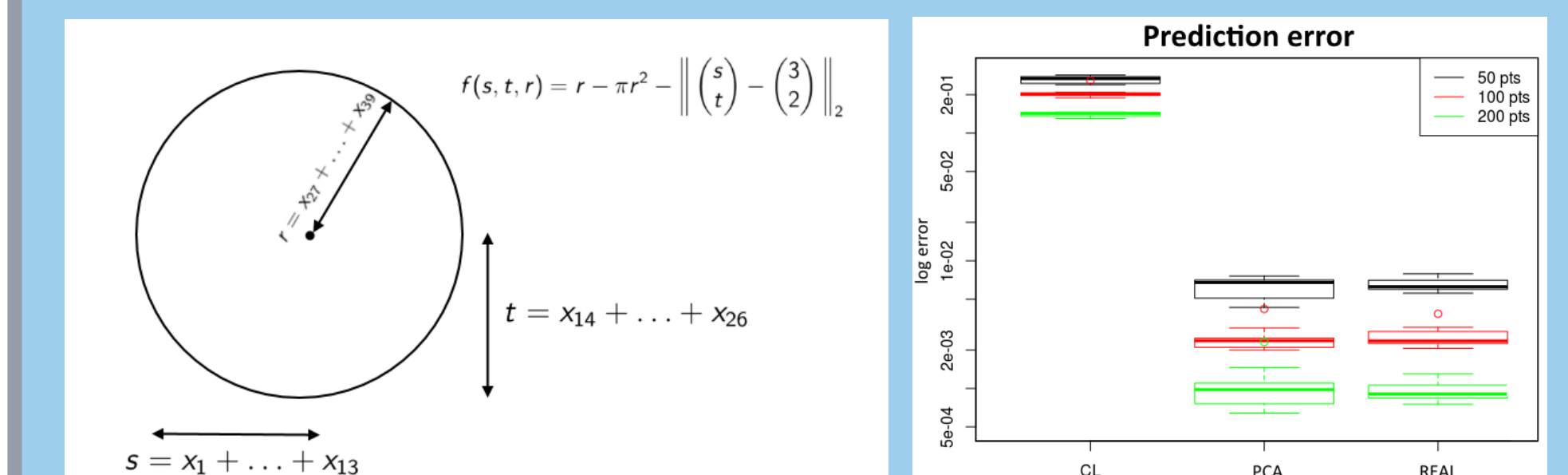

- (b) Meta NACA 3 dimensions, $\mathbf{x} \in \mathbb{R}^3$
 $\rightarrow \delta = 3$

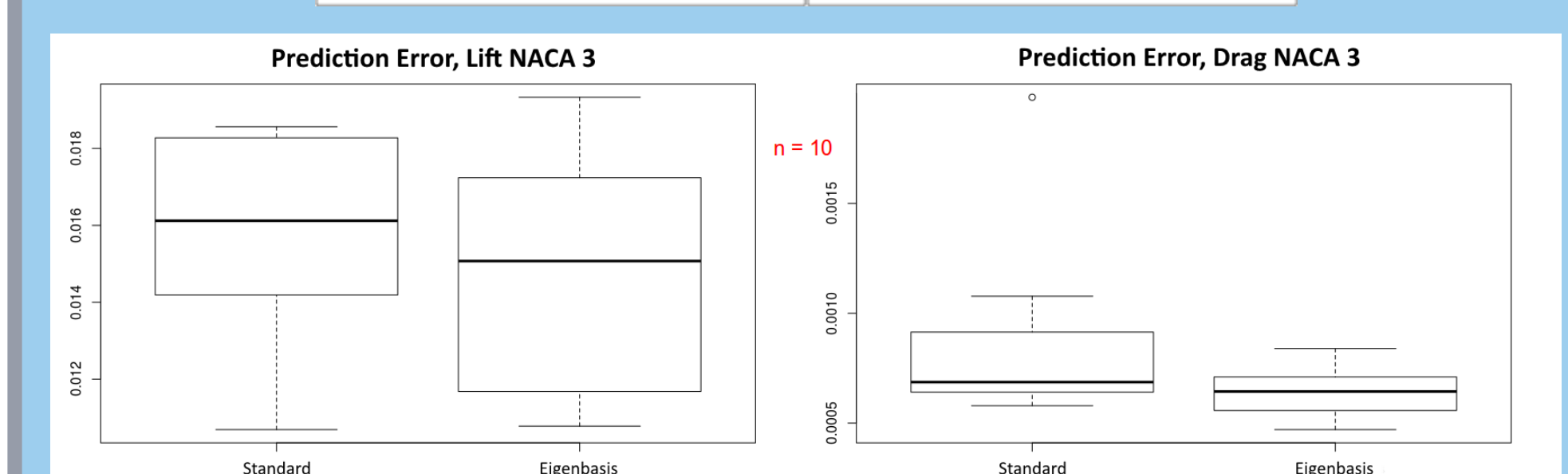
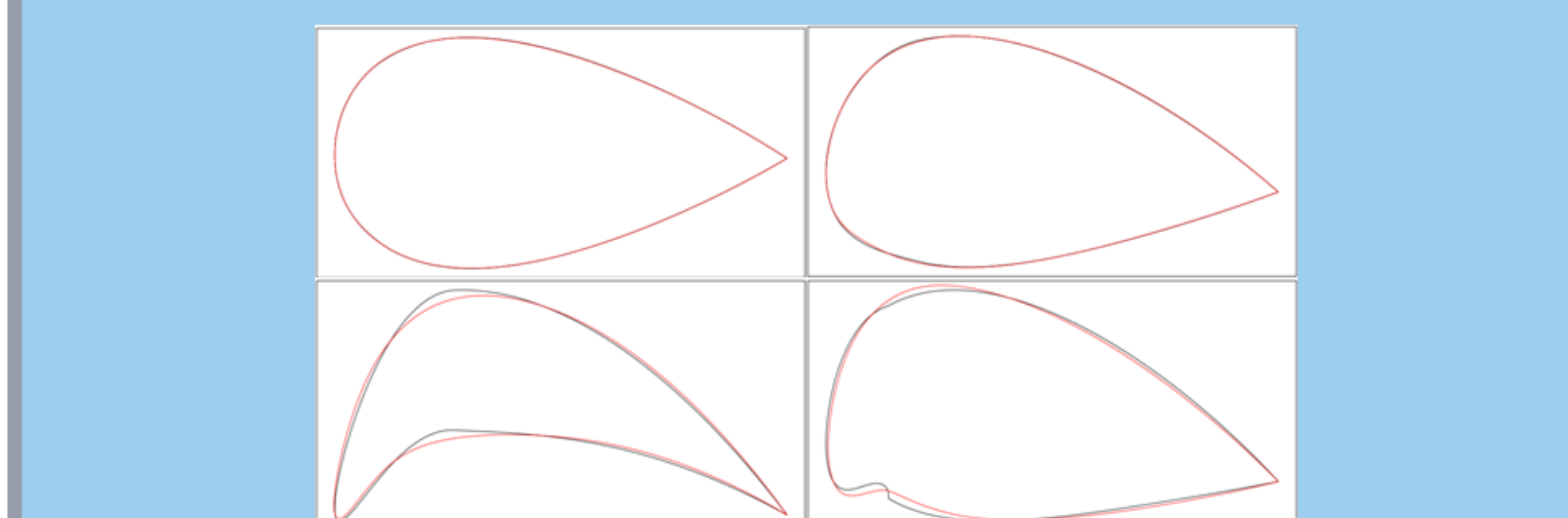

- (c) Meta NACA 22 dimensions (bumpy airfoil), $\mathbf{x} \in \mathbb{R}^{22} \rightarrow \delta = 3, 6, 20$

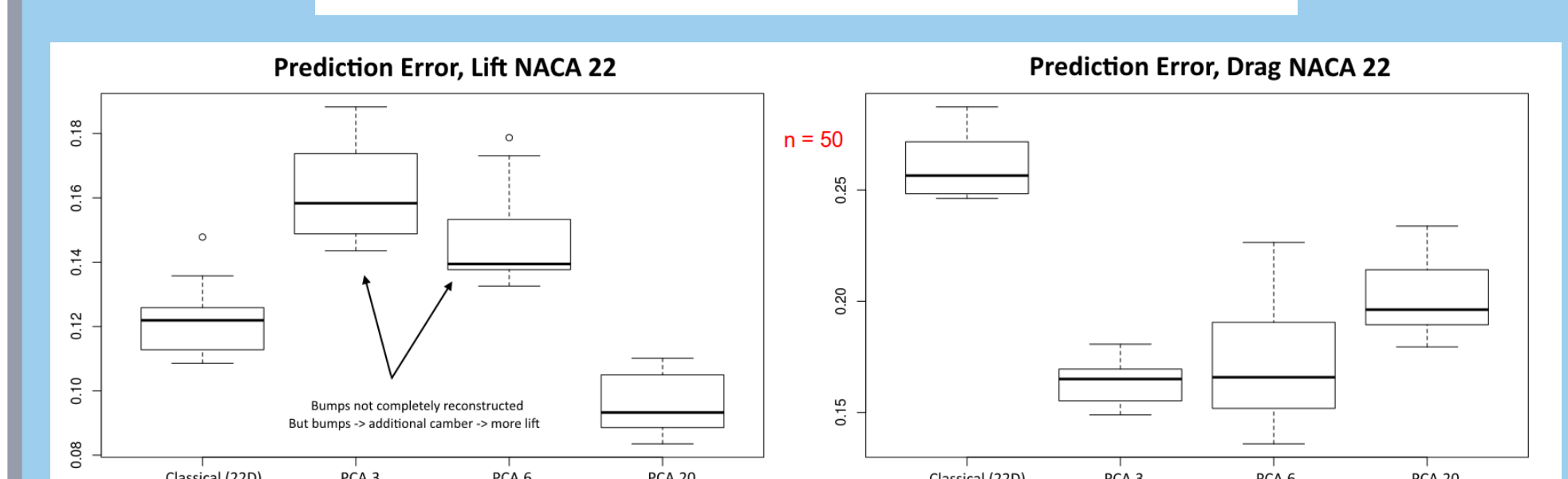
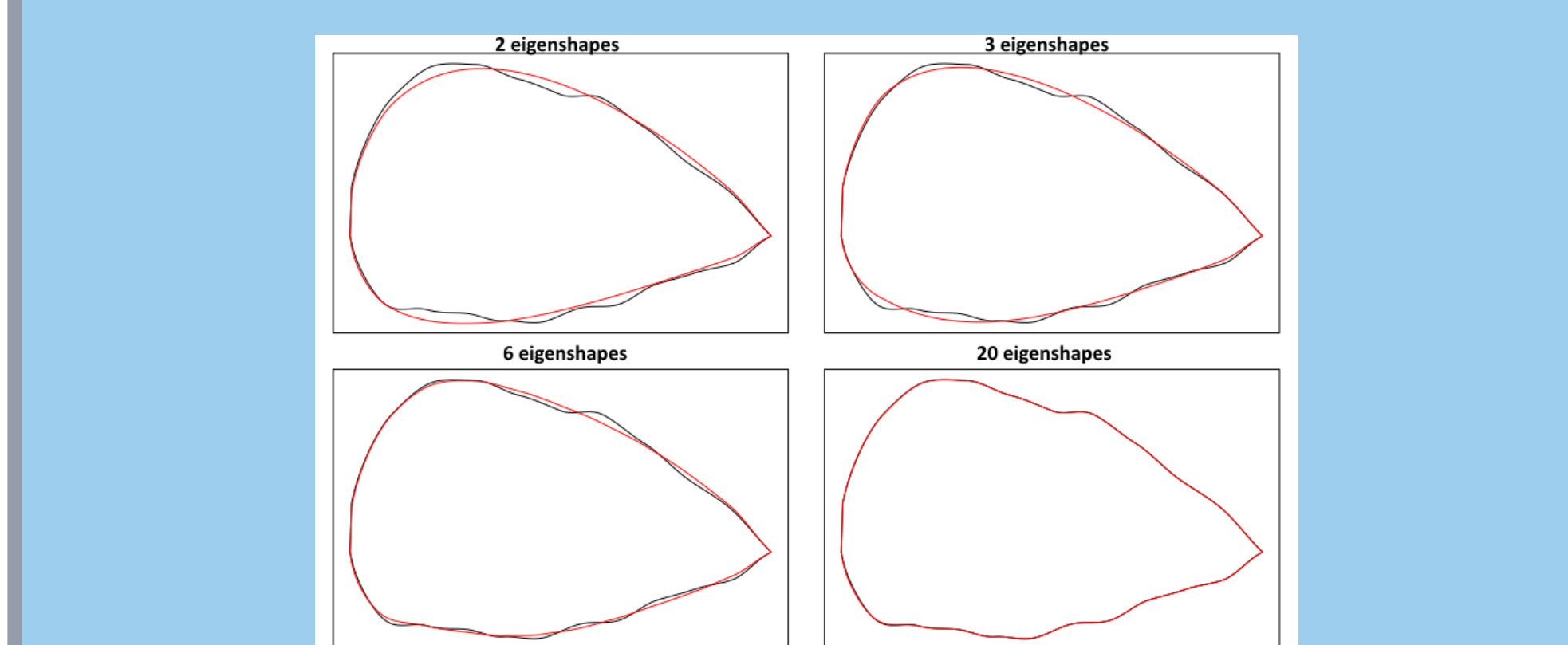

Conclusions

- Lower/true dimension retrieved
- Enhanced predictability in the reduced eigenbasis
- Shape discretization: better than characteristic function and signed distance

Further work

- Invariance of shape discretization under some permutations (points indexing, multiple shapes)
- Use this framework to perform (multi-objective) optimization