



**HAL**  
open science

## Energy valorization of grasses by dry process

Ahmed Wahrani Khirech, J.F. Largeau, Mohand Tazerout

► **To cite this version:**

Ahmed Wahrani Khirech, J.F. Largeau, Mohand Tazerout. Energy valorization of grasses by dry process. WasteEng - Conference on Engineering for Waste and Biomass Valorisation, Jul 2018, prague, Czech Republic. hal-01927075

**HAL Id: hal-01927075**

**<https://hal.science/hal-01927075>**

Submitted on 19 Nov 2018

**HAL** is a multi-disciplinary open access archive for the deposit and dissemination of scientific research documents, whether they are published or not. The documents may come from teaching and research institutions in France or abroad, or from public or private research centers.

L'archive ouverte pluridisciplinaire **HAL**, est destinée au dépôt et à la diffusion de documents scientifiques de niveau recherche, publiés ou non, émanant des établissements d'enseignement et de recherche français ou étrangers, des laboratoires publics ou privés.

# Energy Valorisation of Grasses by Dry Process



Grass clippings

## 1- Context and aims

- ▶ **A waste** : mainly in Europe grass clippings represent a residues and so cost for disposing.
- ▶ **Conventional valorisation** : leave on lawn, compost or in anaerobic digestion
- ▶ **Aim of the work** : study others ways for energy valorisation by dry processes: **Biomass energy (energy storage) and fuel&char by pyrolysis**

## 2- Challenges :

- ▶ Process for energy storage: dry&shape process
  - **Stabilization of biomass** (short time decomposition <48h) due to the high level of moisture (50-80%)
  - **Obtain a useful shape** : grass clippings have not a helpful shape for storage or process
- ▶ **Best Energy carriers** by dry process : biomass energy VS fuel (gas/liquid) and char
- ▶ **Economic** : low-cost process in energy point of view (energy balance)

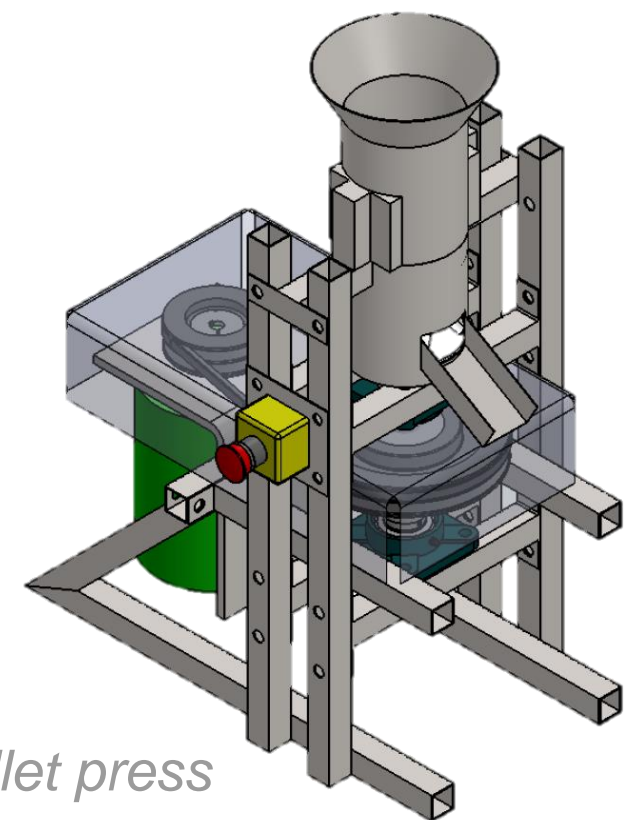

Pellet press

## 3a- Materials and methods - Process for energy storage -

- ▶ **Shredders** : improve the moisture diffusion
- ▶ **Pellet** : pellet press developed by Icam (Ø 6mm, L≈15mm)
- ▶ **Log** : hydraulic press logs of grass + starch or paper (Ø 50mm, L=150mm)
- ▶ **Drying** : ambient air/ tower with forced ventilation

## 3b- Materials and methods - Energy valorisation -

- ▶ Calorimetric bomb : PARR model 6200
- ▶ TGA system : SETARAM Setsys-Evo
- ▶ Pyrolyser : batch process developed by Icam
- ▶ Kinetic method : Arrhenius law with FWO model

$$K(T) = A \exp\left(\frac{-E_a}{RT}\right)$$



Log of grass



Grass pellets

## 4a- Results - Biomass characteristics, energy potential -

- ▶ **Efficiency** : Ratio between thermal energy of log/pellet prod and energy spent and >15
- ▶ **Mechanic handling** : ok with/without starch, ok with paper (if paper < 4%wt)

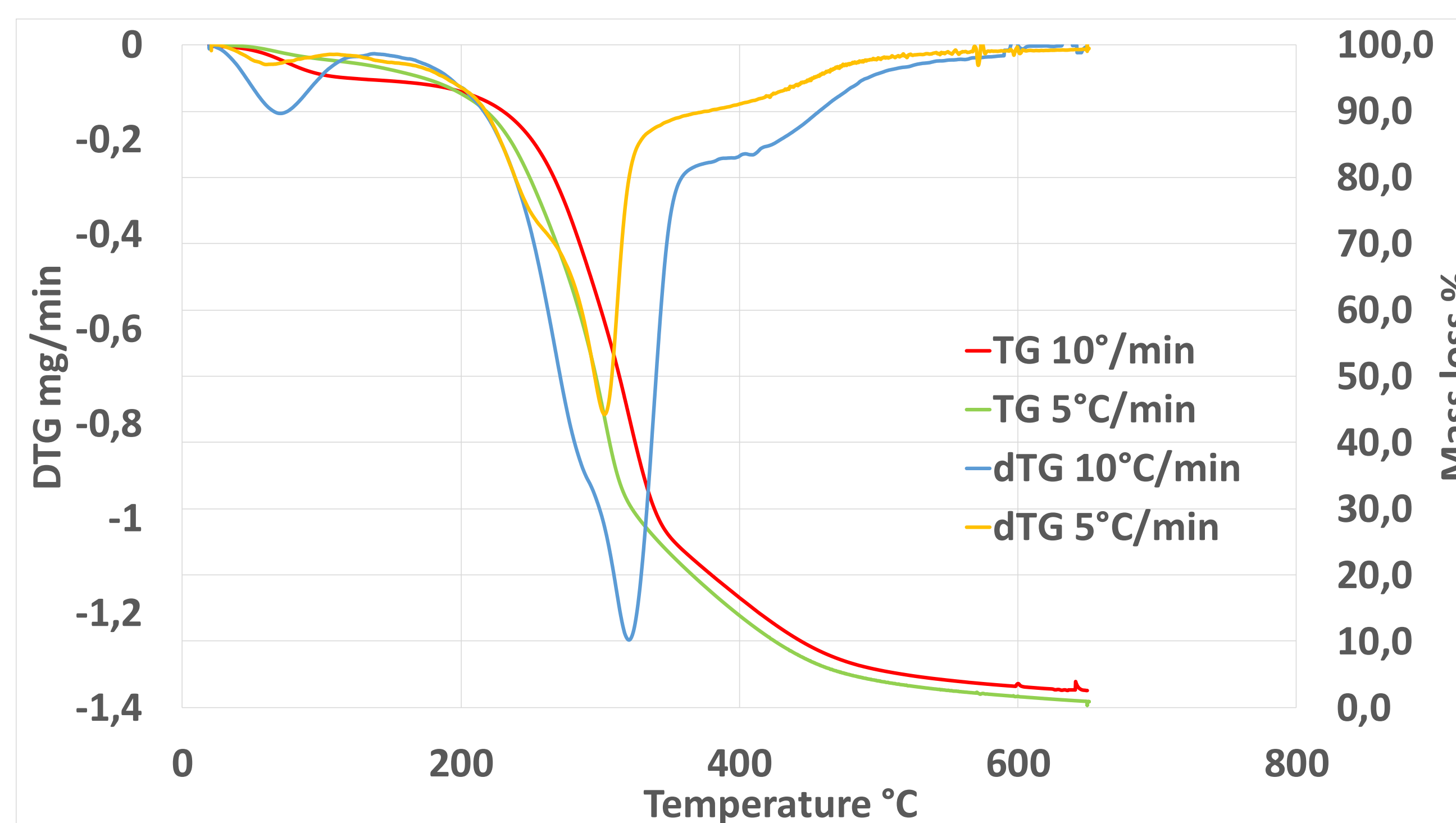

Some TGA results

	Grass - this study -	Herbs residues Guo&Al	Douglas wood
%H	50-80	N/A	N/A
LHV (kWh)	4,6	N/A	5,5
C wt%	74	42	48,1
H wt%	6,6	6,2	5,5
O wt%	17,5	47,4	45,8
N wt%	0,4	1,86	0,4
S wt%	1,5	0,15	0
H/C	0,09	0,15	0,11
O/C	0,24	1,13	0,95
Ashes (%)	7,0	10,8	0,25

## 4b- Results : TGA & kinetic results

- ▶ **TGA** : 3 degradation steps :  
200°C to 290°C (a part of) hemicellulose  
300°C to 360°C hemicellulose + cellulose  
360°C to 600°C lignin

### ▶ Kinetic coefficients

	Grass -this study-	Herbs residues Guo&Al
A [s <sup>-1</sup> ]	1,06E+06	1,00E+06
Ea [J/mol]	146	105-130

- ▶ Slow pyrolysis at 600°C :  
Yields: 69% char, 21%liquid,10%gas

## 5- Conclusions and Perspectives

- ▶ **Dry&shape process** defined to stabilize, store and handling for energy storage (thermal energy)
- ▶ **Kinetic degradation studied** : parameters for dry process valorization identified
- ▶ Work in progress : identification of conversion potential into fuel and char by **pyrolysis**

Guo, F., Dong, Y., Lv, Z., Fan, P., Yang, S., and Dong, L. (2015). Pyrolysis kinetics of biomass (herb residue) under isothermal condition in a micro fluidized bed. *Energy Convers. Manag.* 93, 367–376.

## Authors

Ahmed WAHRANI KHIRECH

Jean-François LARGEAU

Mohand TAZEROUT

CNRS Joint Unit GEPEA  
Department of Energy  
Systems and Environment  
IMT Atlantique  
4 rue Alfred-Kastler BP  
20722, 44307 Nantes,  
France

## Contact



jean-francois.  
largeau@icam.fr

## Partners



## Keywords

Grass clippings  
Energy storage  
Energy valorisation  
Kinetic coefficient  
Pyrolysis