



HAL
open science

Grid-Connected Photovoltaic Generation Plants as Alternative Energy Sources

Enrique Romero-Cadaval, Bruno François, Mariusz Malinowski, Qing-Chang
Zhong

► **To cite this version:**

Enrique Romero-Cadaval, Bruno François, Mariusz Malinowski, Qing-Chang Zhong. Grid-Connected Photovoltaic Generation Plants as Alternative Energy Sources. *IEEE Industrial Electronics Magazine*, 2015, 9, pp.18 - 32. hal-01918172

HAL Id: hal-01918172

<https://hal.science/hal-01918172v1>

Submitted on 9 Nov 2018

HAL is a multi-disciplinary open access archive for the deposit and dissemination of scientific research documents, whether they are published or not. The documents may come from teaching and research institutions in France or abroad, or from public or private research centers.

L'archive ouverte pluridisciplinaire **HAL**, est destinée au dépôt et à la diffusion de documents scientifiques de niveau recherche, publiés ou non, émanant des établissements d'enseignement et de recherche français ou étrangers, des laboratoires publics ou privés.

Grid-Connected Photovoltaic Generation Plants as Alternative Energy Sources

[Enrique Romero-Cadaval](#) ; [Bruno Francois](#) ; [Mariusz Malinowski](#) ; [Qing-Chang Zhong](#)

Abstract— Large photovoltaic (PV) plants are being built all over the world, commonly having ratings up to 1 MW and reaching the level of 250 MW. These plants could be an alternative energy source replacing conventional ones and solving the energy dilemma of humanity. However, the associated electronic systems, mainly inverters used for interfacing with the grid, have to solve some problems related to the operation in the electric distribution system. They should be reliable, robust and manageable. This paper presents and discusses the most critical points existing in actual inverters, summarizing, explaining and proposing approaches to solve or mitigate them.

Keywords: Photovoltaic Plants, Grid Integration, Alternative Renewable Energy Sources.

I. INTRODUCTION

Governments and public organizations are nowadays concerned about the production of energy with technologies as clean as possible [1]. As a consequence, the guidelines for future energy production are established according to the Kyoto protocol [2], which for European countries inspires the “20-20-20” target [3]. The energy production technologies based on hydro, wind, photovoltaic and geothermal energies can be considered to be clean and renewable alternatives to the non-clean conventional technologies based on fossil fuels and nuclear fission. Among the clean technologies, photovoltaic (PV) is one that has experienced a great growth in the last years, close to 60% in Europe.

PV Generation Plants (PVGP) are becoming economically viable, even without government subsidies. The PV plant capacity is increasing continuously all

1 over the world reaching values of hundreds of megawatts (Fig. 1, [4]), thus making
 2 these plants a crucial part of future electric energy systems and Smart Grids. They
 3 are becoming an important agent in Active Distribution Grids as they are distributed
 4 energy sources, and they need special control structures [1].

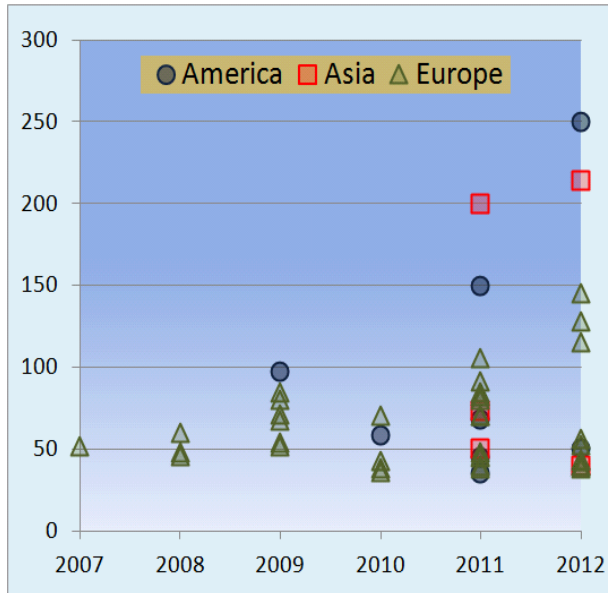

TOP 5 BY POWER

Power	Description and Location	Commissioned
250 MW	Agua Caliente Solar Project USA, Yuma County, AZ	2012
214 MW	Charanka Park, Patan district PV power plant India, Charanka	2012
200 MWp	Golmud PV power plant China, Golmud	2011
150 MW	Mesquite Solar I USA, Sonora desert, AZ	2011
145 MWp	Solarpark Neuhardenberg Germany, Neuhardenberg	2012
128 MW	Solarpark Templin, Germany.	2012
115 MW	Centrale solaire de Toul- Rosières, France.	2012
106 MW	Perovo I-V PV power plant, Ukraine	2011
97 MW	Sarnia PV power plant, Canada	2009
91 MW	Solarpark Briest, Germany	2011

5 Fig. 1 Nominal Power (in MW) of PVGPs classified by the continent where they are
 6 installed [4] and top-ten large-scale PVGPs.

7 These large/medium PVGPs operate as Distributed Energy Resources (DER)
 8 mostly in rural areas where the required surface is available. They are connected to
 9 radial distribution grids as shown in the example of Fig. 2.

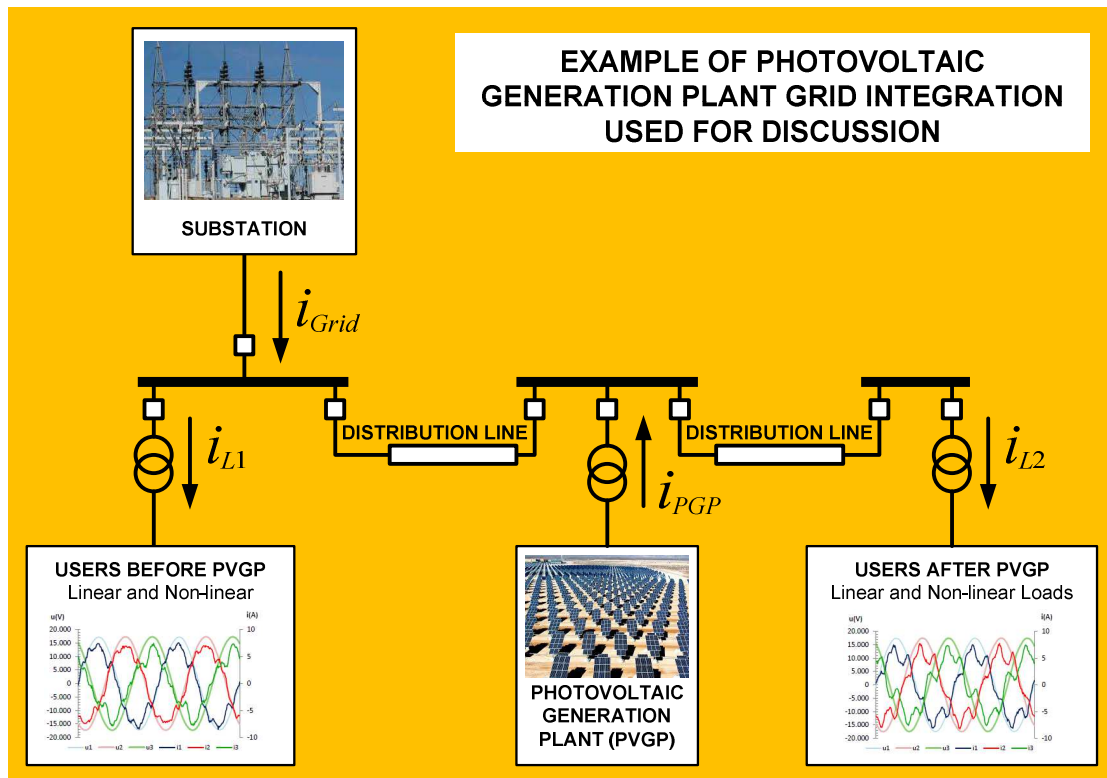

1

2 Fig. 2. Example of distribution grid where a Photovoltaic Generation Plant is
3 connected.

4 Controlling frequency and voltage has always been an essential part of
5 operating a power system. However, since the liberalization of the electricity supply
6 industry, the resources required to achieve this control have been treated as
7 services that the system operator has to obtain from network stakeholders, usually
8 known as ancillary services. Large grid-connected PVGPs should contribute to
9 deliver this service, especially if they have to operate in the isolated mode.

10 Ancillary services are components of electric services, required to support
11 the reliable delivery of electricity and operation of transmission systems [5]. These
12 services contribute to frequency stability (e.g., frequency regulation and operating
13 reserves, in different time scales Fig. 3), power balance (e.g., scheduling and dispatch
14 of balancing energy), voltage control (e.g., tap changer control and reactive power
15 control), restoration of supply (e.g., black start capability and island operation), or

1 system management (e.g., power quality assurance, operation and asset
 2 management).

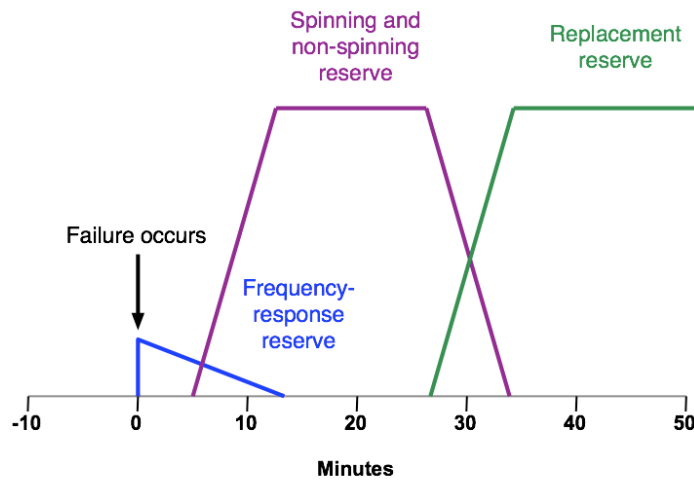

3
 4 Fig. 3. Time Association of Frequency Regulation and Operating Reserves after a
 5 Contingency Occurs

6 In order to maintain power system reliability, the natural intermittent
 7 characteristics of primary renewable energy must be taken into account, requiring
 8 a precise estimation of their ancillary service provision in advance. If necessary,
 9 other utilities, such as Energy Storage Systems (ESS) or fast generators, must be
 10 planned. Hence, the integration of PVGPs into an electrical system implies the
 11 extension of the actual hierarchical power management system that takes into
 12 account different time-scales and economic dispatch. It has to pave the way to
 13 develop new interactions between real-time pricing, physical constraints and
 14 demand response-based loads.

15 At the present, and even more in a future Smart Grid scenario [6], PVGPs can
 16 receive operation references, mainly active and reactive power references to
 17 generate/consume energy for delivering ancillary services, from the corresponding
 18 Electric System Agent. PVGP central control systems will have to translate these
 19 global references into individual operation references for each inverter within the

1 plant, and taking into account the actual state of all the inverters and weather
2 forecast. Therefore, inverters will be the main device that must be able to interact
3 with the grid and with the ESS for providing these services in the required way.

4 This paper presents new solutions that enable PVGPs inverters to provide
5 these ancillary services with the right topology, additional systems, power or
6 current ratios, control algorithms and communication systems. The paper starts
7 with a general overview of the current situation in Section I and continues by
8 presenting in Section II the control structures that are most commonly used for
9 controlling the converters that inject the energy produced by these plants into the
10 grid. In Section III Active PVGPs with embedded ESS and the associated control
11 strategies are discussed. Section IV presents advanced functions that these PVGPs
12 can implement in the near future, in the context of the fore coming Active
13 Distribution Grids, providing ancillary services. In Section V, synchronverters are
14 presented as an alternative to the conventional control structures discussed in
15 previous sections, emulating the operation of conventional synchronous generators.
16 Finally, this paper ends with conclusions.

17 **II. Control of Grid-connected PVGP Inverters**

18 During the last years, PWM converters have drastically increased their
19 importance on the market of energy conversion for PV applications. Two technology
20 breakthroughs enabled these remarkable developments:

- 21 • innovations in the field of power electronics, which brings improvements
22 in efficiency (reduction of switching losses), power density, power quality,
23 common mode voltage and electromagnetic interference, etc.;
- 24 • innovations in the field of control schemes, which contain now many
25 sophisticated control functions (Fig. 4) e.g. inner current/power and

1 outer dc-link control [7-9], maximum power point tracking (MPPT) [4],
 2 monitoring and grid synchronization [10], proper operation at
 3 significantly distorted grid [11], islanding/anti-islanding operation [4],
 4 active power feed-forward [12,13], outer control loop for active/reactive
 5 power to support power system etc. [14,15], energy storage, harmonic
 6 compensation or synchronous generator emulation.

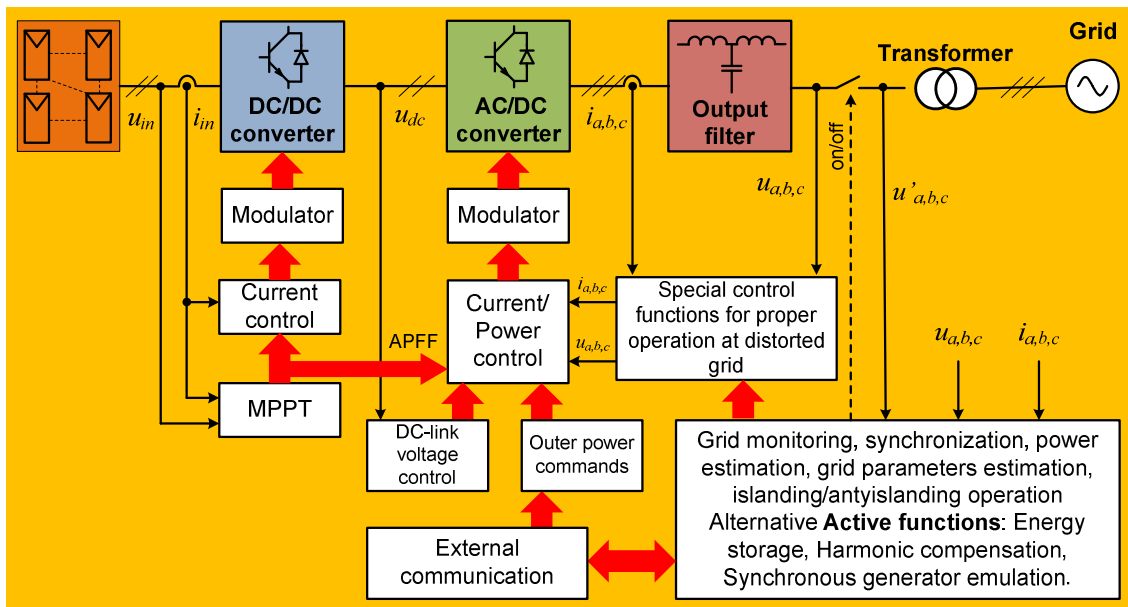

7
 8 Fig. 4. General control structure of grid-connected PV plant.

9 **III. Current-based Control for PVGP Inverters**

10 Various inner control algorithms have been proposed in recent works for this
 11 type of DC/AC PWM converters for MW PV applications [7,8,16] but many of them
 12 are still being developed and they have not found place in industry. Therefore this
 13 paper only describes the methods which are most promising or attractive for
 14 industry – e.g. Voltage Oriented Control (VOC), Direct Power Control Space Vector
 15 Modulated (DPC-SVM) or Predictive Control (PC) – based on the simplified system
 16 scheme shown in Fig. 5.

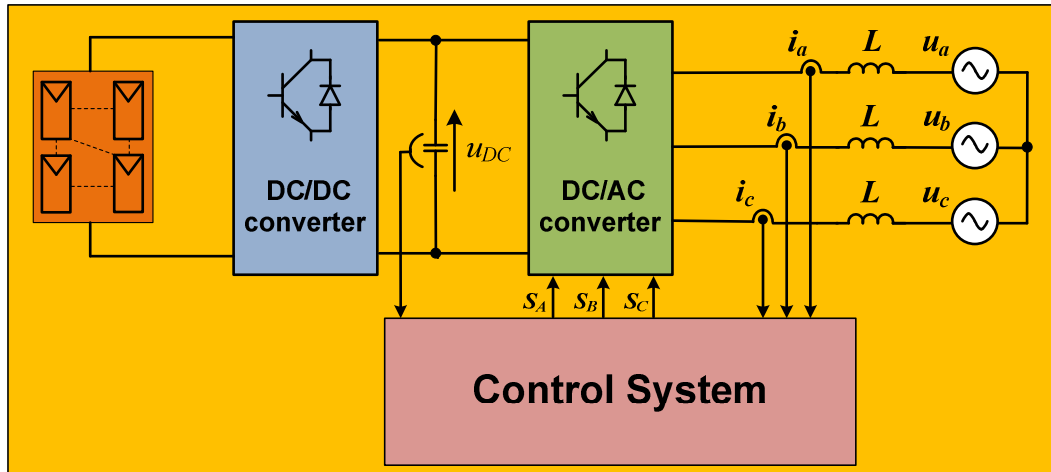

1

2 Fig. 5. Simplified DC/AC PWM converter scheme to facilitate the discussion of
3 control algorithms.

4 The conventional VOC uses closed-loop current control in the rotating
5 reference frame. A characteristic feature for this current controller is the processing
6 of signals in two coordinate systems (Fig. 6), after converting three phase measured
7 values to the equivalent two-phase system $\alpha\beta$ and then to the rotating $d-q$
8 coordinate system via a $\alpha\beta/d-q$ block [16,17].

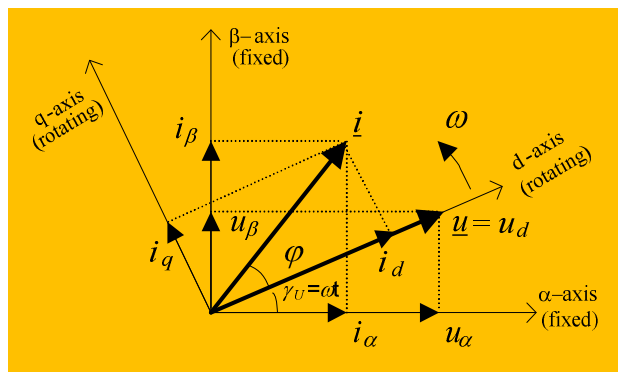

9

10 Fig. 6. Coordinate transformation of line current and line voltage from the
11 stationary $\alpha\beta$ coordinates to the rotating $d-q$ coordinates.

12 As the $d-q$ frame rotates with the same speed as the electrical quantities, the
13 projected coordinates are DC signals. In the voltage oriented $d-q$ frame, the AC grid
14 current vector \underline{i} is split into two rectangular components $\underline{i} = [i_d, i_q]$. The component i_q
15 determines indirectly the reactive power, whereas i_d decides indirectly the active
16 power flow. Thus the reactive power and the active power can be controlled
17 independently. The Unity Power Flow (UPF) condition is met when the grid current
18 vector, \underline{i} is aligned with the grid voltage vector \underline{u} , which means that the q -axis
19 current should be set to zero in all cases while the reference current i_d is set by the

- 1 DC-link voltage controller and controls the active power flow. The output signals
- 2 from Proportional-Integral (PI) controllers after a $dq/\alpha\beta$ transformation are used to
- 3 generate switching signals via a Space Vector Modulator (Fig. 7a).

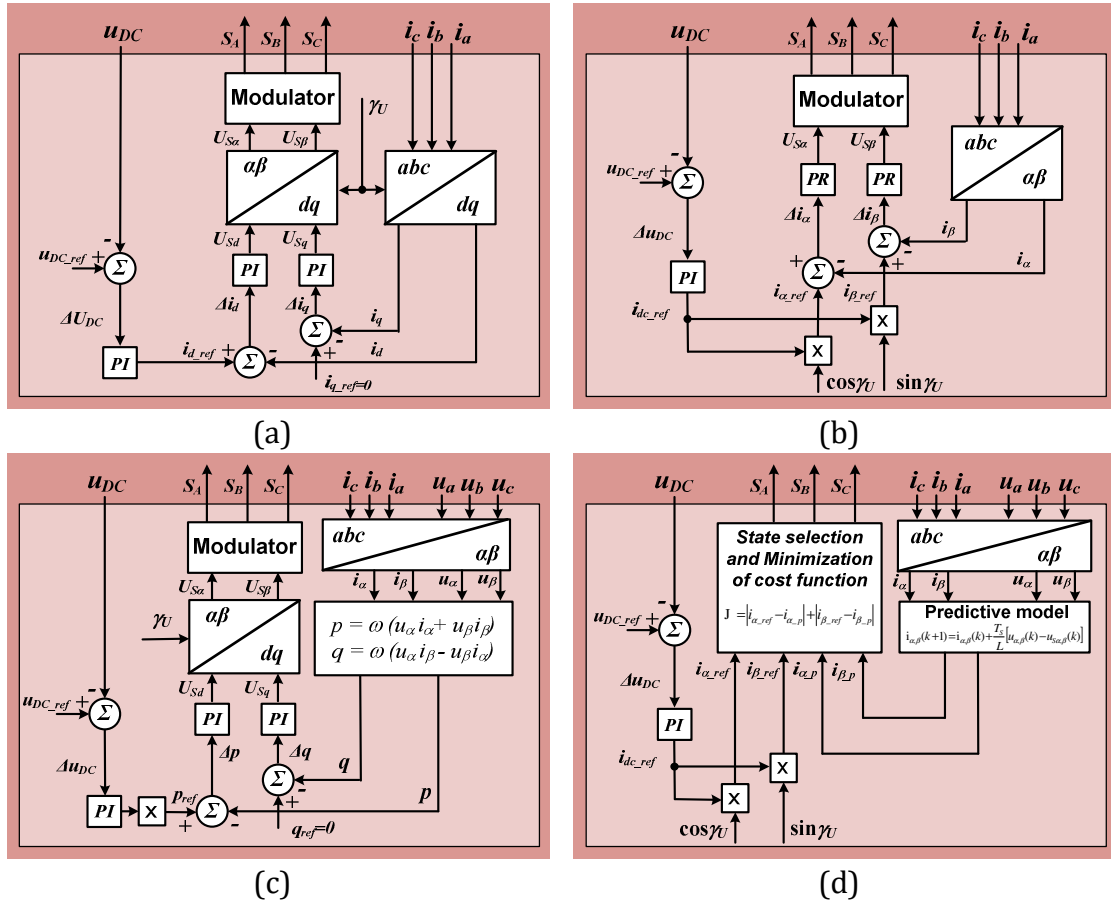

4 Fig. 7. Control System schemes: (a) VOC in the synchronous rotating coordinate
 5 system, (b) VOC in the stationary coordinate system, (c) Direct power control with
 6 the space vector modulator (DPC-SVM), (d) Model Predictive Control (MPC).

7 An important drawback of VOC is the high algorithm complexity (many
 8 coordinate transformations are needed) as well as the sensitivity to grid voltage
 9 distortion. The last drawback can be eliminated [11], but it significantly complicates
 10 the algorithm.

11 The VOC can also be realized in the stationary $\alpha\beta$ coordinate system but PI
 12 controllers cannot be used for current regulation because they result in a steady
 13 state error. However, this can be solved by replacing PI current regulators with
 14 Proportional/Resonant controllers (PR), which consist of a proportional gain and a
 15 resonant integrator. The transfer function of a PR controller contains a pair of
 16 conjugate poles tuned at the fundamental grid frequency ω , which allows perfect
 17 tracking of sinusoidal signals without any error [13].

1 A basic block diagram of the VOC in the stationary coordinate system is
 2 shown in Fig. 7b and it is based on an inner current control loop with PR and an
 3 outer voltage control loop with PI. The commanded dc-link voltage u_{dc}^* is compared
 4 with the measured u_{dc} voltage. The error is delivered to the PI controller, which
 5 generates the amplitude of the commanded current i_{dc_ref} . Next, this current is
 6 multiplied by the angle of the line voltage u_L as $\cos(\omega t)$ and $\sin(\omega t)$ to get i_{α_ref} and i_{β_ref} .
 7 These reference current signals in the stationary coordinate system are compared
 8 with the measured grid currents i_α and i_β and the errors are delivered to the PR
 9 controller. The outputs of the PR controller are directly (without transformation)
 10 used to generate switching signals by a Space Vector Modulator (SVM).

11 An interesting feature of this control is the proper operation under distorted
 12 grid voltages by connecting multiple PR compensators, which are tuned at specific
 13 high order harmonics, e.g. 5th, 7th, in parallel [13,18,19].

14 Another less known method is direct power control – space vector modulated
 15 (DPC-SVM) which uses inner loops of active and reactive power control (Fig. 7c) [20].
 16 The commanded reactive power q_{ref} (set to zero for UPF operation) and active power
 17 p_{ref} values (delivered from the outer PI-DC voltage controller) are compared with
 18 the estimated q and p values, respectively. The errors are delivered to PI controllers
 19 to eliminate steady-state errors because they are DC quantities. The output signals
 20 from the PI controllers after transformation from the stationary to synchronous
 21 rotating coordinates are used to generate switching signals by a SVM.

22 Recently, a very popular control scheme called Model Predictive Control (MPC)
 23 (Fig. 7d) has been applied to control inverters. It is based on the mathematical model
 24 of the controlled system and the calculation (prediction) of future values of the state
 25 variables. It is assumed that the system can represent a finite number of states in
 26 every time period [21-25]. Thus, first of all, the model must be as accurate as possible,
 27 because the control performance is highly dependent on the parameters. Using
 28 measured values of grid currents, their values in the forthcoming sampling can be
 29 calculated, with respect to available control states. It must be done for all switching
 30 states in each iteration of the algorithm.

31 Some features of predictive control are very interesting, e.g. fast dynamics and
 32 the capability of dealing with multiple constrains, which is very attractive especially
 33 for high power converters operating at very low switching frequency (500Hz-

1 1000Hz). Unfortunately, MPC has some drawbacks, e.g. variable switching frequency
 2 (causing difficulties for the design of the LC input EMI filter), high sampling frequency
 3 needed for digital implementation (demand of fast microprocessor) and sensitivity
 4 to parameter variations of the grid filter, etc, which cause difficulties in implementing
 5 MPC in industry. All the above drawbacks can be eliminated when a constant
 6 switching frequency is applied but it significantly complicates the control algorithm
 7 [26].

8 The advantages and features of the control schemes described above are
 9 summarized in Table I.

10 Table I – Advantages and features of control schemes for DC/AC converter in PV
 11 applications

	VOC (Fig. 7a)	VOC (Fig. 7b)	DPC-SVM (Fig. 7c)	MPC (Fig. 7d)
Operation in stationary coordinate system	NO	YES	YES/NO	YES
Power control – indirect	YES	YES	NO	YES
Power control – direct	NO	NO	YES	NO
Constant switching frequency	YES	YES	YES	NO
Low algorithm complexity	NO	YES/NO	YES/NO	YES
Low computation intensity	YES	YES	YES	NO
Low sensitivity to line inductance variation	YES	YES	YES	NO
Low sensitivity to line voltage distortion	THD of line current	NO	YES	NO
	Power factor	YES	NO	YES

12

13 IV. Active PV Generators with Embedded Energy Storage Systems

14 Electrical systems must ensure a balance between production and
 15 consumption at all times, while maintaining a satisfactory voltage. Historically, grid
 16 reliability was mainly ensured by having excessive capacity in the system with
 17 unidirectional flow from centrally dispatched large power plants to dispersed
 18 consumers. Dispatched production refers to sources of electricity that can be
 19 dispatched at the request of system operators. They are able to change their power
 20 production upon demand.

21 The large scale development of intermittent PV sources causes large amount of
 22 variable power [27]. Renewable energy based generators with intermittency
 23 decrease the reliability of a power system. As the percentage of intermittent
 24 generation capacity increases and becomes more significant, an additional

1 uncertainty is appearing in the real time management of the electrical system
2 balance between demand and generation. This requires increasing amounts of
3 conventional power reserve capacity that can be available immediately (spinning
4 reserve) and of plants capable of providing ancillary services (frequency response
5 and voltage control as example), which are required to manage the electrical power
6 system securely [28].

7 However, an electrical generation system depending entirely on the renewable
8 energy sources is not reliable because the availability of the renewable energy
9 sources cannot be constantly ensured.

10 Because of the intermittency of PV power generation, PVGP cannot be used as
11 a stable, reliable and controllable power source and cannot provide ancillary
12 services like conventional generators. One solution is to upgrade PVGP with an
13 embedded Energy Storage System (ESS) and a Local Energy Management System
14 (LEMS) for the coordination of inner power flows. Storage technologies are varying
15 and first it is essential to characterize the required need and complementary
16 performances they must offer. Typically, an energy reserve must be provided to the
17 electrical system and can be implemented by long-term energy storages. Moreover,
18 the supply of power with fast dynamics is also mandatory to smooth the generated
19 PV power, compensate the power gap and absorb instantaneous high power peaks.
20 At the present state of art, a high energy storage unit, delivering high power with
21 fast dynamics in a reduced volume, does not exist and a mix of storage technologies
22 has to be considered [29]. Lead acid batteries for long term energy storage device
23 and ultracapacitors for fast dynamic power regulation are today realistic and
24 economic choices [30], but other technologies can also be considered [31], as Fuel
25 Cells, REDOX batteries [32,33] or Flywheels [34].

1 Storage devices can be used to store or to release electrical power like an
2 energy buffer. Therefore, they can help to solve problems due to renewable energies'
3 intermittent availabilities and fast transients. A PVGP combined with ESS can be
4 considered as an Active PV Generator for the grid since it can supply ancillary
5 services as conventional generators. Moreover it can be dispatched and then
6 provide a power reference that is demanded by the grid operator [35].

7 A general structure that has been widely used in isolated power systems for
8 integrating ESS is based on the direct connection of a battery bank to the DC-bus of
9 the grid-connected inverter. A PV controller is used to extract the Maximum Power
10 from PV panels and send it to the battery bank. However, the stochastic nature of
11 the PV power output and power demand leads to fast charge/discharge actions of
12 batteries and a fast battery ageing.

13 To enable a more efficient use of batteries, AC-coupled and DC-coupled power
14 electronic converters can be considered in order to have control abilities of the
15 exchanged powers with the batteries thanks to the development of power
16 electronics. In an AC-coupled Hybrid Power Generators (HPG) structure, all sources
17 are connected to the main AC network (Fig. 8a) [35]. A communication network is
18 required to implement the coordination of this set. In a DC-coupled HPG, all sources
19 are connected to a common inner DC-bus before being connected to the grid through
20 a main inverter (Fig. 8b) [36]. One advantage is that the battery bank is connected
21 to the dc-bus via a DC/DC converter, which can be used to implement an optimized
22 charge/discharge operation mode. The second advantage is that a super capacitor
23 bank is added and is also connected to the DC bus via another DC/DC converter.
24 Hence fast power compensation can be performed. The PV array is connected to the
25 DC bus via a PV converter. Apart from these two coupling structures, a mixed

- 1 structure can be also used (Fig. 8c) with some advantages taken from both of DC and
- 2 AC coupled structures.

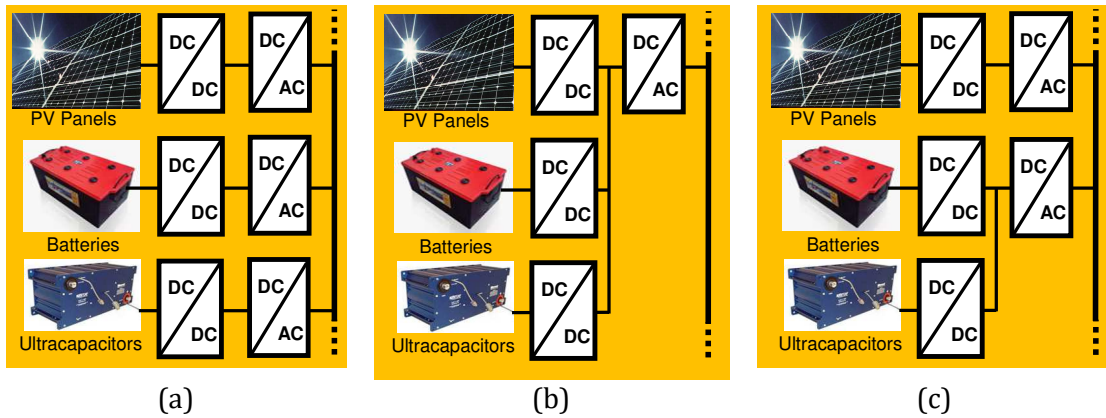

3 Fig. 8. Various structures of Hybrid ESS embedded in PVGPs: (a) AC-coupled, (b) DC-
4 coupled, and (c) Mixed structure.

5 Fig. 9 outlines the main required devices to design a DC-coupled Active PV
6 Generator HPG prototype. The grid connection is performed by a three-phase
7 inverter. Chokes and capacitors are used to filter the modulated electrical
8 waveforms.

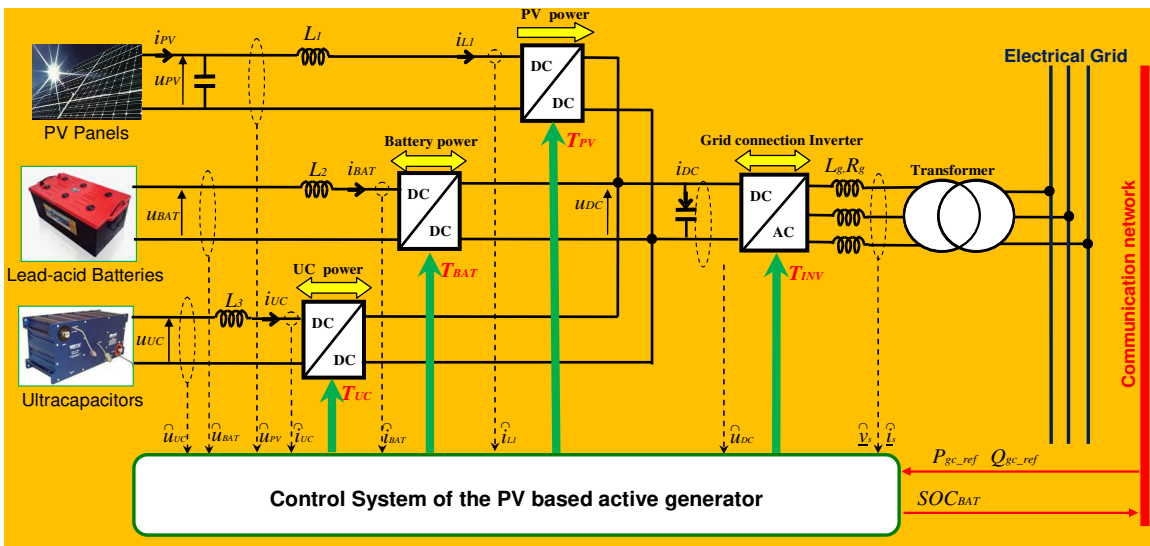

9 Fig. 9. Example of a Grid-connected Active PV Generator with control.

11 In order to ensure an optimal operation and coordination, a LEMS of the active
12 PV generator must calculate and send control signals to each power electronic
13 converter in order to enable

- 14 • the production of power demand for the grid operator,

- 1 • the management of renewable energy intermittency,
- 2 • the management of storage State of Charges,
- 3 • the power system protection,
- 4 • the provision of grid ancillary services.

5 For example, a hierarchical structure of the control system is shown in Fig. 10 and
6 has four stages:

- 7 • the Switching Control (SC),
- 8 • the Automatic Control (AC),
- 9 • the Power Control (PC),
- 10 • the Mode Control (MC).

11 The SC stage implements the modulation technique to each converter and
12 generates the switching signals. The AC stage implements control algorithms in
13 order to meet the current or voltage references. The PC stage calculates these
14 references according to power references from the MC level and measured values.
15 The MC level decides the operating mode for the whole hybrid generator according
16 to the availability of the PV production, the state of each storage unit and the actual
17 power demand from the grid.

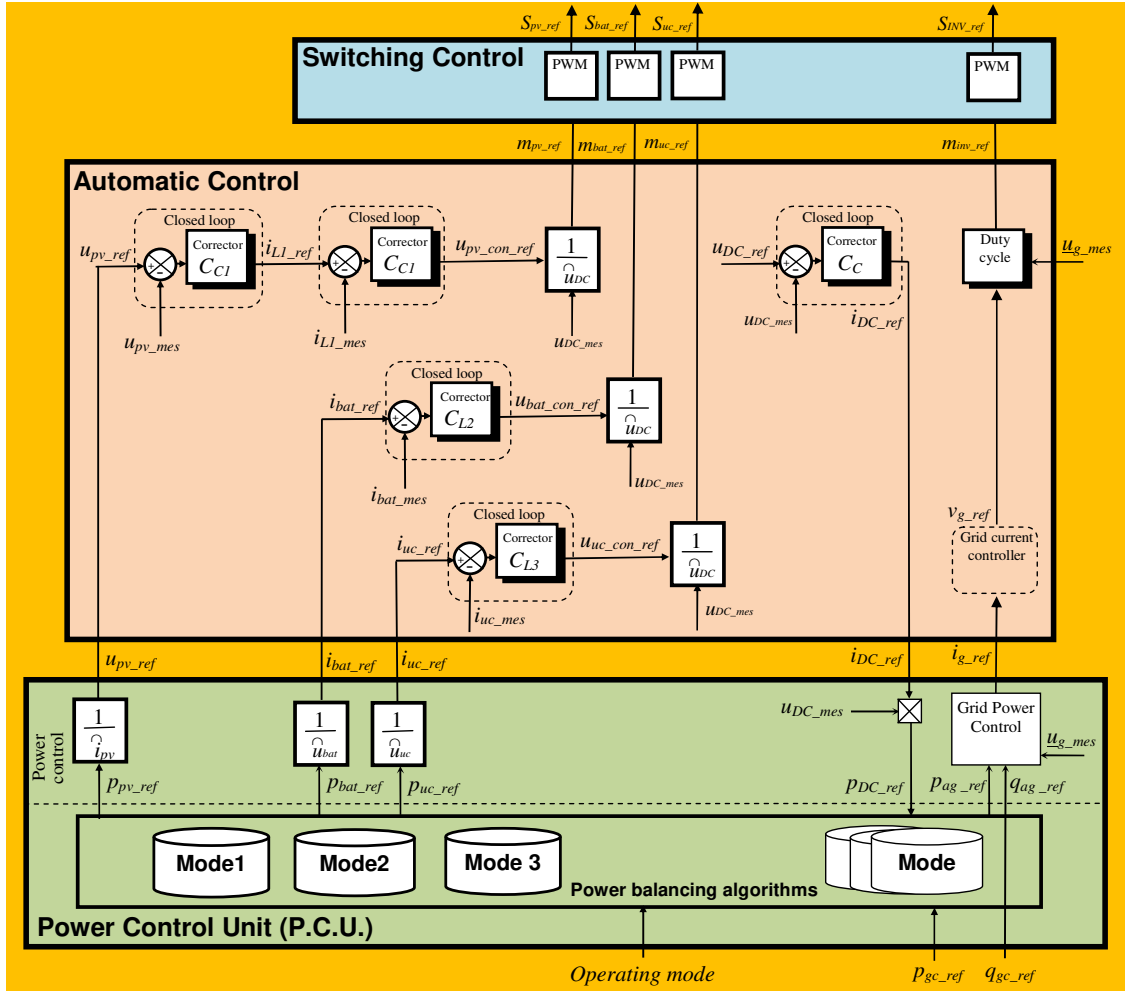

1

2 Fig. 10. Global control scheme of active PV generator.

3 The power reference for the PV generator, $p_{PV_ref}(t)$, is classically calculated from
 4 a Maximum PV Power Tracking algorithm. The inner power balancing shows that
 5 powers from the PV, $p_{PV}(t)$, the battery, $p_{BAT}(t)$, the ultracapacitor, $p_{UC}(t)$ must be
 6 decreased by the required power to regulate the DC bus, $p_{DC}(t)$, and constitutes the
 7 total generated power [37]:

$$p_{ag}(t) = p_{BAT}(t) + p_{UC}(t) + p_{PV}(t) - p_{DC}(t) \quad (1)$$

8 With a “Grid following strategy” (Fig. 11a), the reference for the power to be
 9 generated by the inverter is deduced by using the measured power and contributes
 10 to the regulation of the DC bus:

$$p_{ag_ref}(t) = \widehat{p}_{BAT}(t) + \widehat{p}_{UC}(t) + \widehat{p}_{PV}(t) - p_{DC_ref}(t) \quad (2)$$

1 Then the required power reference from the grid operator is provided by the
 2 storage units by taking into account the available PV power.

$$p_{sto_ref}(t) = p_{gc_ref}(t) - \hat{p}_{PV}(t) \quad (3)$$

3 A simple method to dispatch the power between batteries and ultracapacitors is
 4 used with a low-pass filter [38]. Ultracapacitors are controlled to supply the
 5 required transient power from storage units.

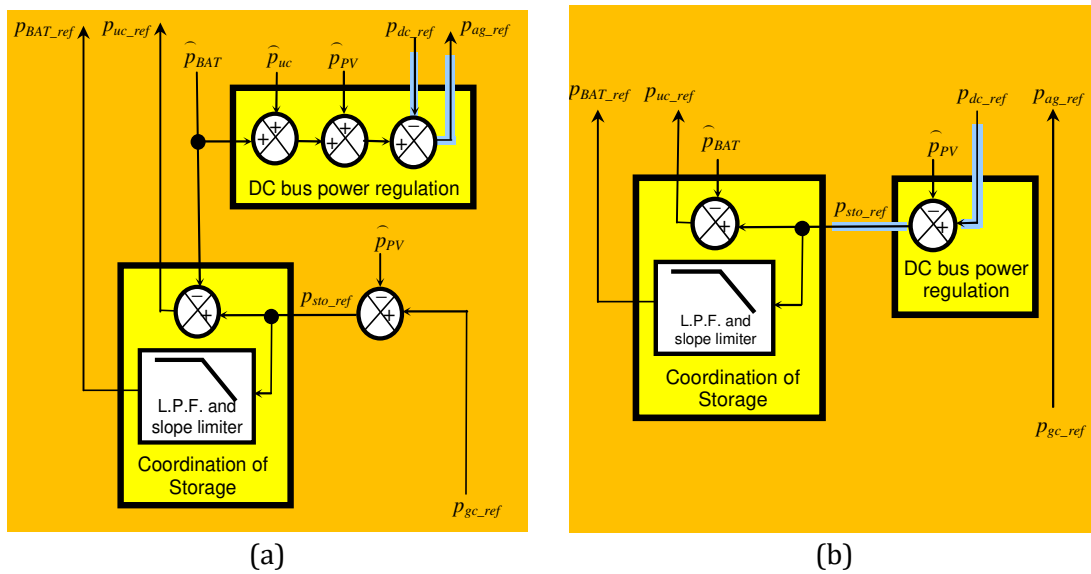

6 Fig. 11. Operation strategies: (a) Grid following strategy, (b) Source supplying
 7 strategy.

8 With a “Source supplying strategy” (Fig. 11b), the power from the storage units is
 9 adjusted according to the sensed PV power to regulate the DC bus. The required
 10 power reference fixed by the grid operator is directly provided by the inverter.

11 With both strategies, the PV generator can be dispatched by the grid operator
 12 since it is now able to deliver the prescribed active and reactive powers ($p_{gc_ref}(t)$,
 13 $q_{gc_ref}(t)$), but only “Source supplying strategy” is able to work without a connection
 14 to the grid because the DC bus is regulated by the inner power. This strategy is
 15 preferred since autonomous, or isolated, operation is possible and may be used to
 16 store PV energy without grid connection. Another advantage is the possibility to stay
 17 connected in case of grid AC undervoltage because the dc bus voltage is

1 autonomously regulated by inner sources (PV panels and storage units). Hence, real
 2 and reactive power generation is possible to help the electrical network in this
 3 situation.

4 An experimental test is presented on Fig. 12 using this strategy, having a step
 5 change in the reference power to be injected into the grid (p_{gc_ref}). During the test,
 6 the batteries cannot immediately supply all the surplus production when the PV
 7 power production changes or when the PV production decreases fast, so the
 8 ultracapacitors help to perform the power balancing.

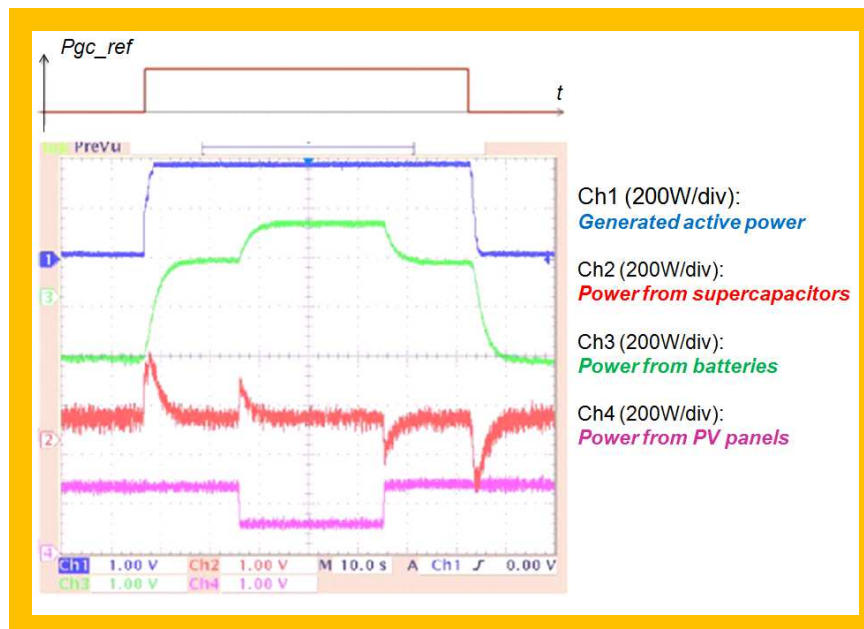

9 Fig. 12. Experimental performances of an active based generator.

10 V. Ancillary Services: Active, Reactive and Harmonic Control

11 As previously discussed, most PVGPs operate as current sources and inject
 12 into the grid the energy produced by photovoltaic cells tracking the Maximum
 13 Power Point (MPP) [4]. The electronic converters generate a reference current that
 14 is sinusoidal, in phase with the grid voltage, and with the required root mean
 15 squared (RMS) value to achieve the operation in the MPP.

16 If the PVGPs want to become an alternative to conventional energy sources
 17 they also have to provide ancillary services [1,39,40] including the control of active

1 power [39], reactive power [39,41] and compensation of harmonics [42,43]. In
2 order to achieve this, most of the Distribution System Operators (DSO) are
3 establishing various codes to regulate how these plants should operate.

4 If it is assumed that the distribution grid voltage is sinusoidal, then the
5 following current components can be defined, according to power definitions given
6 by IEEE-Standard 519 [44]:

- 7 • Active or Direct current component, i_P , that is related to the average active
8 power (P).
- 9 • Reactive or in-Quadrature component, i_Q , related to the fundamental
10 reactive power (Q)
- 11 • Harmonic component, i_H , related to the Harmonic Power (H).

12 Usually only the active current component is controlled in conventional
13 PVGPs and the others are set to zero.

14 In a Smart Grid context, where Active Distribution Grids are an strategic
15 priority [45], PVGPs offer a unique opportunity to increase the operation
16 possibilities of energy generators as they are distributed sources that have free
17 capacity (because most of the time they operate under its nominal power, mainly
18 during nights) to be used to help grid management.

19 If we consider an ideal photovoltaic generation day where the maximum
20 power reaches the 90% of the nominal power ratio of the Inverter, we can discount
21 the active component from the nominal current obtaining the available current
22 (non-active current), I_{NA} , given by (4)

$$I_{NA}^2 = I_N^2 - I_P^2 = I_Q^2 + I_H^2 \quad (4)$$

23

1 In the proposed case of Fig. 13a, I_{NA} (Fig. 13b) could reach values that, depending on
 2 the time of the day, vary from 40% to 100% of the nominal current. In the previous
 3 section it has been discussed how the active component can be controlled by using
 4 ESS, in this section the attention is focused on how this non-active current
 5 component availability can be used to generate other current components, such as
 6 reactive or harmonic ones.

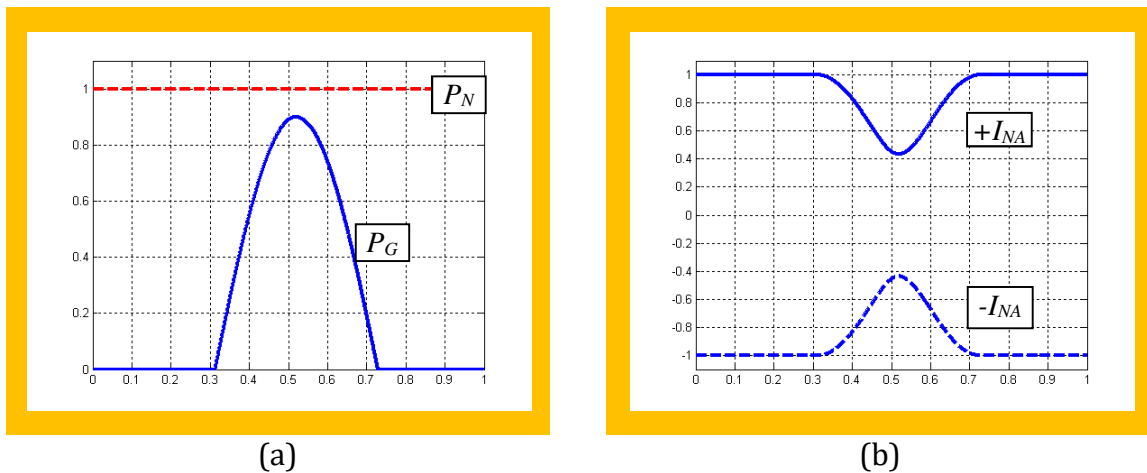

7 Fig. 13. Non-active current (p.u.) (b) that can be produced depending on the power
 8 generated by the PVGP, P_G (p.u.) in relation with its nominal power, P_N (a).

9 By controlling the reactive component it is possible to stabilize the grid via
 10 controlling the grid frequency [41] or the voltage [46] at the Point of Common
 11 Coupling (PCC) where the PVGP is connected. By controlling the voltage at this point,
 12 it is also possible to prevent over-voltages and reduce grid losses [47]. Grid losses
 13 can be reduced further if an optimization strategy is applied in multi-bus systems
 14 [48].

15 Therefore, the reactive component can be used during abnormal grid or
 16 transient states, mainly during faults or after-faults, in order to compensate voltage
 17 sags [49]. In three-phase balanced voltage sags, the PVGP should inject reactive
 18 power in order to raise the voltage in all phases. In one- or two-phase faults, the

1 main concern of the PVGP is to equalize voltages by reducing the symmetric negative
 2 and, if possible, the homopolar (or zero) sequences [46].

3 PVGPs can generate harmonic component to prevent the effects of the
 4 current harmonic produced by non-linear loads connected to the grid, operating as
 5 integrated Active Power Filters [42,43,50,51]. PVGPs could even compensate
 6 current unbalance [50] or control the leakage or earth current [52] avoiding the
 7 propagation into the grid. For example, in the case presented in Fig. 14, the current
 8 produced by the PVGP is not sinusoidal because it contains the harmonic
 9 components demanded by the load achieving in this way a sinusoidal current
 10 flowing into the grid (and so a harmonic compensation).

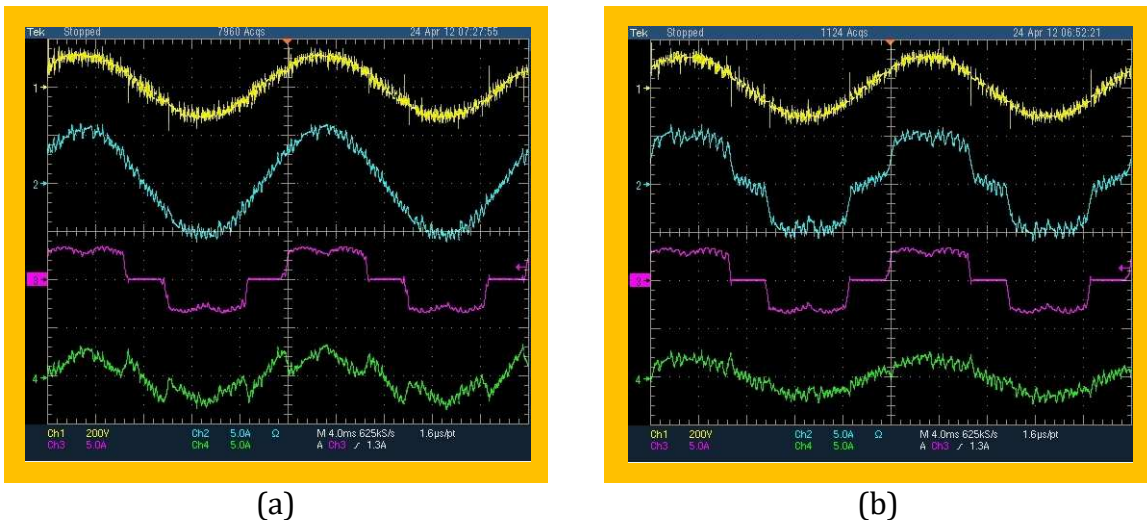

11 Fig. 14. Example of injecting the harmonic component: (a) harmonic injection
 12 turned OFF, and (b) harmonic injection turned ON. Curves from top to bottom:
 13 Phase-to-neutral grid voltage, Inverter current, Local load current, and Current
 14 flowing to the substation.

15 In some cases, dual or collaborative topologies are used, associating the
 16 different current components under control to different converters [50,51].

17 When the active, reactive and harmonics components that PVGP should
 18 generate are greater than the available non-active components, some kind of
 19 priority has to be established. This operation priority could be dependent on the
 20 status of the grid, being different in normal and abnormal states [53].

1 The possibilities of PVGP, as a manageable distributed generation, are much
2 more interesting than conventional centralized energy resources. For example, in
3 the proposed initial system of Fig. 2, PVGP could generate the reactive power for
4 controlling the voltage at the PCC or to compensate the reactive power consumed
5 by connected loads. PVGP can also generate the harmonic component needed to
6 compensate the harmonics components of current i_{L1} and i_{L2} , which prevent these
7 harmonic currents from flowing from the substation. By controlling properly the
8 PVGP we can assure that the current demanded from the grid, i_{Grid} , will be sinusoidal
9 and in phase with the substation voltage, achieving a unity power factor, reducing
10 distribution losses and preventing any undesirable effect on the substation
11 transformers.

12 **VI. Grid-friendly connection of PVGP through inverters that mimic** 13 **synchronous generators (Synchronverters)**

14 As previously discussed, most of PVGP operate as current sources to inject
15 the energy produced into the grid. When the penetration level of PVGP reaches a
16 certain level, PVGPs should also provide ancillary services. As demonstrated in the
17 previous section, these can be achieved by controlling the current injected into the
18 grid. Another way is to control the grid-connected inverters to behave like
19 conventional synchronous generators so that PVGPs can interact with the grid in a
20 friendly way [1, 54-56,71-77].

21 Synchronverters [54,56] are inverters that mimic synchronous generators.
22 As shown in Fig. 15a, the basic idea is to embed the mathematical model of a
23 synchronous generator [57-59] given below as the core of the controller for the
24 inverter in the general scheme (Fig. 4):

$$\begin{cases} \ddot{\theta} &= \frac{1}{J}(T_m - T_e - D_p\dot{\theta}) \\ T_e &= pM_f i_f \langle i, \widetilde{\sin\theta} \rangle \\ e &= \dot{\theta} M_f i_f \widetilde{\sin\theta} \\ Q &= -\dot{\theta} M_f i_f \langle i, \widetilde{\cos\theta} \rangle \end{cases} \quad (5)$$

1
2 where T_m is the mechanical torque applied to the rotor; T_e is the electromagnetic
3 torque; e is the three-phase generated voltage; θ is the rotor angle; Q is the reactive
4 power; J is the moment of inertia of all the parts rotating with the rotor; D_p is the
5 friction coefficient, p is the number of pairs of poles of the magnetic field, i is the
6 stator current; i_f is the field excitation current; M_f is the maximum mutual inductance
7 between the stator windings and the field winding and $\dot{\theta}$ is the angular speed of the
8 machine. The vectors $\widetilde{\sin\theta}$ and $\widetilde{\cos\theta}$ are defined, respectively, as

$$\widetilde{\sin\theta} = \begin{bmatrix} \sin\theta \\ \sin(\theta - \frac{2\pi}{3}) \\ \sin(\theta - \frac{4\pi}{3}) \end{bmatrix}, \quad \widetilde{\cos\theta} = \begin{bmatrix} \cos\theta \\ \cos(\theta - \frac{2\pi}{3}) \\ \cos(\theta - \frac{4\pi}{3}) \end{bmatrix}. \quad (6)$$

9

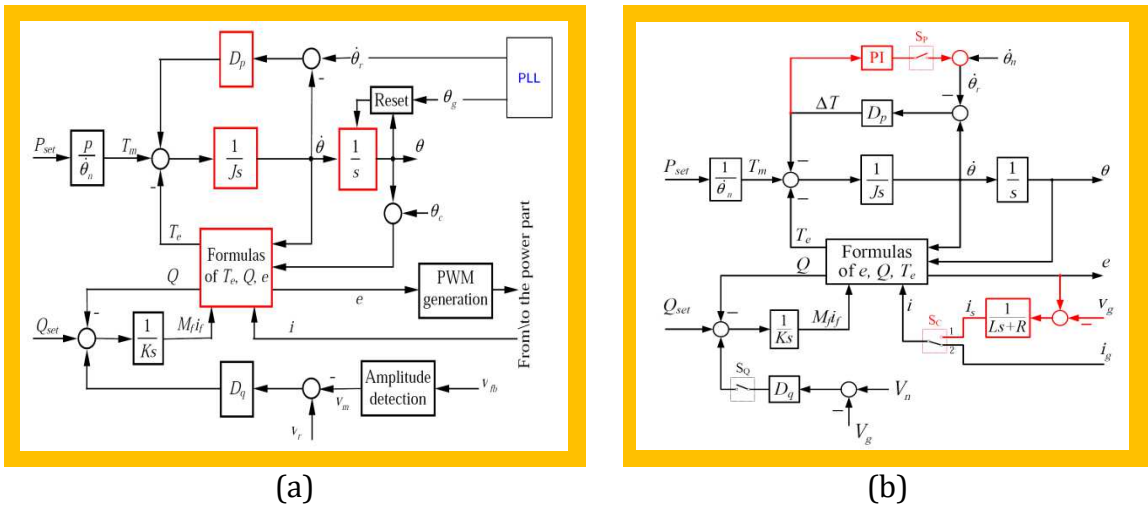

10 Fig. 15. Controllers for synchronverters (a) the original version [54,56], and (b) the
11 improved version without the need of a dedicated synchronization unit [62].

12 The generated voltage e is converted into PWM pulses to turn on/off the switches of
13 the inverter in the general scheme (Fig. 5). The inductor current is measured and
14 fed back to the mathematical model as the stator current, as shown in Fig. 15a. This
15 closes the loop between the controller and the power part of the inverter. On top of

1 this, the matured frequency droop and voltage droop control strategies are applied
 2 to regulate the frequency and voltage of the synchronverter through the frequency
 3 droop coefficient D_p and the voltage droop coefficient D_q , which are defined,
 4 respectively, as

$$D_p = \frac{\Delta T}{\Delta \dot{\theta}}, \quad D_q = \frac{\Delta Q}{\Delta V}, \quad (7)$$

5 according to the desired change of real power (torque ΔT) with respect to the
 6 change of the frequency $\Delta \dot{\theta}$ and the desired change of reactive power ΔQ with
 7 respect to the change of the voltage ΔV . Note that the friction coefficient D_p actually
 8 performs the function of frequency droop control so there is no need to introduce
 9 an extra loop to regulate the frequency, which simplifies the control structure and
 10 the associated parameter tuning process.

11 The controller of a synchronverter shown in Fig. 15a has two channels. The
 12 upper channel has a cascaded structure, where the inner loop is the frequency loop
 13 (with the feedback gain D_p) and the outer loop is the real power loop (with the
 14 feedback coming from the current i via the torque T_e). For a given time constant of
 15 the frequency loop τ_f , the virtual moment of inertia J is

$$J = \tau_f D_p \quad (8)$$

16 This channel regulates the (imaginary) frequency of the generated voltage e and
 17 creates the phase angle θ for the control signal e . The lower channel has a cascaded
 18 structure, with the inner loop to regulate the voltage and the outer loop to regulate
 19 the reactive power. This channel regulates the field excitation $M_f i_f$ to control the
 20 amplitude of the generated voltage. For a given time constant of the voltage loop
 21 τ_v , the parameter K can be chosen as [57-59]

$$K = \dot{\theta}_n \tau_v D_q, \quad (9)$$

23

1 where $\hat{\theta}_n$ is the nominal angular frequency. Hence, the frequency control, voltage
 2 control, real power control, and reactive power control are all integrated in one
 3 compact controller with only four parameters. Fig. 16 demonstrates the frequency
 4 regulation capability of a synchronverter tested in the lab, where the real power
 5 output of the synchronverter automatically changed according to the change of the
 6 frequency.

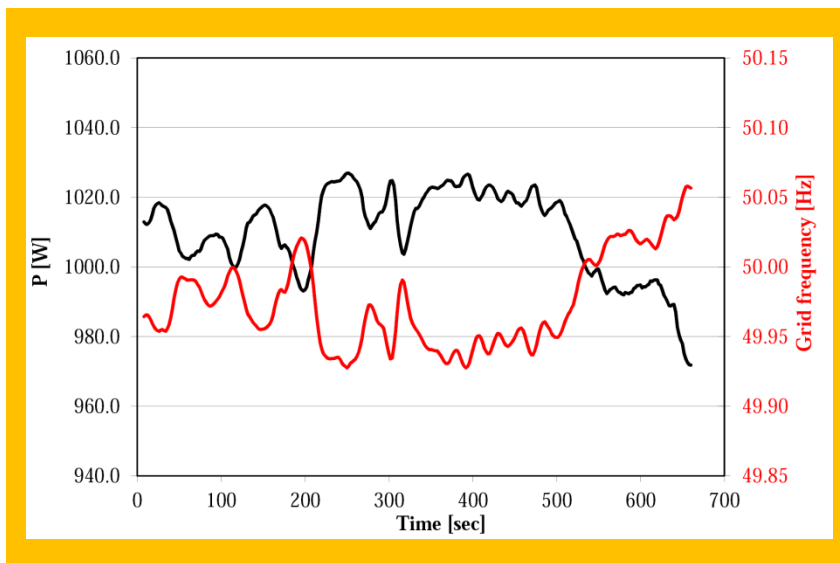

7 Fig. 16. Frequency regulation of a synchronverter.

8 A phase-locked loop (PLL) is adopted to obtain the grid frequency and phase
 9 so that the synchronverter is able to synchronize with the grid. However, PLLs are
 10 difficult to tune and often cause problems [60,61]. The PLL in a synchronverter can
 11 be removed to achieve a self-synchronised synchronverter [62], as shown in Fig. 15b,
 12 after making some changes (highlighted in red) to the original synchronverter. This
 13 has taken advantage of the inherent synchronization property of synchronous
 14 generators. As a result, a self-synchronized synchronverter can synchronize with
 15 the grid before it is connected to the grid and keep synchronized with the grid after
 16 it is connected to the grid, without the need of a dedicated synchronization unit.

17 Table II – Examples of commercial high power DC/AC converters for PVGPs [18].

Parameter	ABB PVS800-MWS,	Danfoss Central PV	Satcon	Siemens Sinvert	SMA Sunny Central
-----------	--------------------	-----------------------	--------	--------------------	----------------------

	PVS800-IS*	Inverters*	Prism Platform Equinox*	PVS 600 series to PVS2400*	
Power	up to 1,25MW up to 2MW*	up to 1,5MW	up to 1,25MW	up to 2,4MW	up to 1,6MW
dc voltage range	525–825V 525–850V*	455–950V	525–825V	570–750V	583–820V
Max. dc voltage	1000V 1100V*	1000V	1000V	820/1000V	1000/1100 V
Output AC voltage	20kV 400V*	430V*	320V*	370V*	20kV
Max. Efficiency	97.8% 98.8%*	98%*	98.5%*	98.6%*	98.2%
Harmonic distortion	<3%	<3%	<3%	-	<3%
Independent MPPT	2	-	2	4	2

*- converter without MV separation transformer

VII. CONCLUSIONS

PVGPs connected to the grid are increasing both in the number of installations and also in the rated power of each plant, becoming a significant part of the electric generation mix, and offering an important opportunity to change the present distribution grid toward a more intelligent and efficient operation.

In this paper, a comprehensive overview of control structures and their abilities to implement active distribution grid functions have been presented, with the aim of giving ideas for future improvements and research activities in the field.

Some of these methods and functions described in this paper are already used by commercial MW rated PVGP converters, as shown in Table II. Other functions are being considered for next generation of Smart Inverters, opening for Industrial Electronic Researchers an interesting working field that will change in the near future the electric grid from the one we know at the present.

The current research and industry trends for power electronics converters used in PVGPs focus on several important aspects including costs, losses, failure rate, weight and volume [63].

The design of power electronic converters and passive elements must be optimized to decrease losses and increase efficiency. Possible solutions are based on new topologies [64] and new semiconductor components such as silicon carbide

1 (SiC) components [65,66], the elimination of transformer and direct operation in MV
2 grid, the replacement of low frequency passive components by high frequency
3 transformers and inductances [16], the fast and precise GMPPT [67] and new
4 modulation methods [68].

5 Other very important trends especially in industry include modular and
6 redundant systems for proper post fault operation, highly reliable and commercially
7 available topologies [69], enhanced energy storage technologies and the integration
8 of photovoltaic plants into smart grids including additional functions such as grid
9 support (V, f, Q control), fault ride through and harmonic compensation [69,70].

10 REFERENCES

- 11 [1] Q.-C. Zhong, and T. Hornik, "Control of Power Inverters in Renewable Energy and
12 Smart Grid Integration", Wiley, 2013.
- 13 [2] Kyoto protocol, <http://www.kyotoprotocol.com/>.
- 14 [3] European Commission, "The EU climate and energy package,"
15 http://ec.europa.eu/clima/policies/package/index_en.htm.
- 16 [4] E. Romero-Cadaval, G. Spagnuolo, L.G. Franquelo, C.A. Ramos-Paja, T. Suntio, and
17 W.M. Xiao, "Grid-Connected Photovoltaic Generation Plants," IEEE Industrial
18 Electronics Magazine, September 2013, pp. 6-20.
- 19 [5] A.S. Chuang, and C. Schwaegerl, "Ancillary services for renewable integration,"
20 Integration of Wide-Scale Renewable Resources into the Power Delivery System,
21 CIGRE/IEEE PES Joint Symposium, 2009.
- 22 [6] V. Calderaro, V. Galdi, F. Lamberti, and A. Piccolo, "A Smart Strategy for Voltage
23 Control Ancillary Service in Distribution Networks," IEEE Trans. on Power Systems,
24 PP, pp.1-9, 2014.
- 25 [7] M. Kazmierkowski, R. Krishnan, and F. Blaabjerg, "Control in Power Electronics,"
26 Academic Press, 2002.
- 27 [8] B. Wilamowski, and D. Irwin, "Industrial Electronics Handbook," Taylor & Francis
28 Group, 2011.
- 29 [9] M. Malinowski, "Sensorless control strategies for three-phase PWM rectifiers," PhD
30 Thesis, Warsaw University of Technology, Warsaw, Poland, 2001,
31 www.isep.pw.edu.pl/icg.
- 32 [10] R. Teodorescu, M. Liserre, and P. Rodríguez, "Grid Converters for Photovoltaic and
33 Wind Power Systems," Wiley-IEEE Press, 2011.
- 34 [11] M.P. Kazmierkowski, M. Jasinski, and G. Wrona, "DSP-Based Control of Grid-
35 Connected Power Converters Operating Under Grid Distortions," IEEE Trans. on
36 Industrial Informatics, no 2, pp: 204-211, 2011.
- 37 [12] M. Jasinski, "Direct power and torque control of AC-DC-AC converter-fed induction
38 motor drives," Ph.D. Thesis, Warsaw University of Technology, Warsaw, Poland,
39 2005, www.isep.pw.edu.pl/icg.
- 40 [13] S. Stynski, "Analysis and Control of Multilevel AC-DC-AC Flying Capacitor Converter
41 Fed from Single-Phase Grid," PhD Thesis Warsaw University of Technology, 2011,
42 www.isep.pw.edu.pl/icg.

- 1 [14] "Power Plant Control for Utility-Scale Photovoltaic Installations,"
2 <http://www.skytron-energy.com>.
- 3 [15] J. M. Guerrero, M. Chandorkar, T.-L. Lee, and P. C. Loh, "Advanced Control
4 Architectures for Intelligent Microgrids – Part I: Decentralized and Hierarchical
5 Control," IEEE Trans. on Industrial Electronics, vol.60, no. 3, pp. 1254-1262, April
6 2013.
- 7 [16] M. Malinowski, M. P. Kazmierkowski, and A. Trzynadlowski "A Comparative Study of
8 Control Techniques for PWM Rectifiers in AC Adjustable Speed Drives," IEEE Trans.
9 on Power Electronics, vol.18, no. 6, pp. 1390-1396, November 2003.
- 10 [17] B. T. Ooi, J. W. Dixon, A. B. Kulkarni, and M. Nishimoto, "An integrated AC drive system
11 using a controlled current PWM rectifier/inverter link," in proc. IEEE-PESC Conf.,
12 1986, pp.494-501.
- 13 [18] H. Abu-Rub, M. Malinowski, and K. Al-Hadad "Power Electronics for Renewable
14 Energy Systems, Transportation and Industrial Applications," John Wiley&Sons, 2014
15 (Chapter 7, S. Kouro, B. Wu, H. Abu-Rub, F. Blaabjerg "Photovoltaic Energy Conversion
16 Systems").
- 17 [19] R. Teodorescu, F. Blaabjerg, M. Liserre, and P. C. Loh, "A new breed of proportional-
18 resonant controllers and filters for grid-connected voltage-source converters," IEE
19 Proc. on Electric Power Applications, vol.153, no. 5, pp. 750-762, Sep 2006.
- 20 [20] M. Malinowski, M. Jasinski, and M.P. Kazmierkowski, "Simple Direct Power Control of
21 Three-Phase PWM Rectifier Using Space-Vector Modulation (DPC-SVM)," IEEE Trans.
22 on Industrial Electronics, vol.51, no. 2, pp. 447-454, April 2004.
- 23 [21] J. Rodriguez, and P. Cortes "Predictive Control of Power Converters and Electrical
24 Drives," John Wiley&Sons, 2012.
- 25 [22] J. Rodriguez, J. Pontt, C. A. Silva, P. Correa, P. Lezana, P. Cortes, and U. Ammann,
26 "Predictive Current Control of a Voltage Source Inverter," IEEE Trans. on Industrial
27 Electronics, vol.54, no. 1, pp. 495-503, 2007.
- 28 [23] M. P. Kazmierkowski, "Current control techniques for three-phase voltage-source
29 PWM converters: A survey," IEEE Trans. on Industrial Electronics, vol.45, no.5, pp.
30 691-703, 1998.
- 31 [24] P. Cortes, M. P. Kazmierkowski, and R. M. Kennel, "Predictive Control In Power
32 Electronics and Drives," IEEE Trans. on Industrial Electronics, vol.55, no.12, pp. 4312-
33 4324, 2008.
- 34 [25] S. Kouro, P. Cortes, R. Vargas, U. Ammann, and J. Rodriguez, "Model Predictive Control
35 – A Simple and Powerful Method to Control Power Converters," IEEE Trans. on
36 Industrial Electronics, vol.56, no. 6, pp. 1826-1838, 2009.
- 37 [26] P. Antoniewicz "Predictive Control of Three-Phase AC/DC Converters," PhD Thesis,
38 Warsaw University of Technology, Warsaw, Poland, 2009, www.isep.pw.edu.pl/icg.
- 39 [27] B. Robyns, A. Davigny, B. François, A. Henneton, and J. Sprooten, "Electricity
40 Production from Renewables Energies," Wiley, 2012.
- 41 [28] A.D. Peacock, D. Jenkins, M. Ahadzi, A. Berry, and S. Turan, "Micro wind turbines in the
42 UK domestic sector," Journal Energy and Buildings, vol.40, no.7, pp.1324-1333, 2008.
- 43 [29] X. Yu, and K. Strunz, "Combined long-term and short-term access storage for
44 sustainable energy system," 2004 IEEE Power Engineering Society General Meeting,
45 vol.2, pp. 1946-1951, 10 June 2004.
- 46 [30] STORE Project press release. [http://www.endesa.com/en/saladeprensa/noticias/
47 energy-storage-plants-STORE-Project](http://www.endesa.com/en/saladeprensa/noticias/energy-storage-plants-STORE-Project)
- 48 [31] M.A. Guerrero, E. Romero, F. Barrero, M.I. Milanés, and E. González, "Overview of
49 medium scale energy storage systems," Compatibility and Power Electronics CPE'09,
50 pp. 93-100, 2009.
- 51 [32] G. Wang, M. Ciobotaru, and V.G. Agelidis, "Minimising output power fluctuation of
52 large photovoltaic plant using Vanadium Redox Battery storage," 6th IET
53 International Conference on Power Electronics, Machines and Drives (PEMD 2012),
54 Marzo 2012.

- 1 [33] Intelligent storage systems based on vanadium redox flow technology.
2 <http://energy.gildemeister.com/en/>
- 3 [34] Fiber Carbon Flywheels. Beacon Power. <http://beaconpower.com/carbon-fiber-flywheels/>
- 4
- 5 [35] P. Li, P. Degobert, B. Robyns, and B. Francois, "Implementation of interactivity across
6 a resilient microgrid for power supply and exchange with an active distribution
7 network," CIREN Seminar 2008: SmartGrids for Distribution, Frankfurt, June 2008.
- 8 [36] H. Fakham, D. Lu, and B. Francois, "Power Control Design of a battery charger in a
9 Hybrid Active PV generator for load-following applications," IEEE Trans. on Industrial
10 Electronics, vol. 58, no.1, pp. 95 – 104, 2011.
- 11 [37] H. Kanchev, D. Lu, F. Colas, V. Lazarov, and B. Francois, "Energy management and
12 power planning of a microgrid with a PV-based active generator for Smart Grid
13 Applications," IEEE on Trans. on Industrial Electronics, vol. 58, no.10, 2011.
- 14 [38] D. Lu, H. Fakham, T. Zhou, and B. Francois "Application of Petri Nets for the energy
15 management of a photovoltaic based power station including storage units,"
16 Renewable energy, Elsevier, vol. 35, no.6, pp. 1117-1124, 2010.
- 17 [39] F. Blaabjerg, R. Teodorescu, M. Liserre, and A. V. Timbus, "Overview of Control and
18 Grid Synchronization for Distributed Power Generation Systems," IEEE Trans. on
19 Industrial Electronics, vol. 53, no. 5, pp. 1398-1409, 2006.
- 20 [40] M. Altin, O. Goksu, R. Teodorescu, P. Rodriguez, B.-B. Jensen, and L. Helle, "Overview
21 of recent grid codes for wind power integration," in Proc. 12th Int. Conf. Optim. Elect.
22 Electron. Equipment, pp. 1152–1160, May 2010.
- 23 [41] J.T. Bialasiewicz, "Renewable Energy Systems With Photovoltaic Power Generators:
24 Operation and Modeling," IEEE Trans. on Industrial Electronics, vol. 55, no. 7, pp.
25 2752-2758, 2008.
- 26 [42] Yu-Kang Lo, Ting-Peng Lee, and Kuan-Hung Wu, "Grid-Connected Photovoltaic
27 System With Power Factor Correction," IEEE Trans. on Industrial Electronics, vol. 55,
28 no. 5, pp. 2224-2227, 2008.
- 29 [43] V. Minambres-Marcos, E. Romero-Cadaval, M.A. Guerrero-Martinez, M.I. Milanés-
30 Montero, "Three-phase single stage photovoltaic inverter with active filtering
31 capabilities," IECON 2012 - 38th Annual Conference on IEEE Industrial Electronics
32 Society, pp. 5253-5258, 2012.
- 33 [44] IEEE Standard Definitions for the Measurement of Electric Power Quantities Under
34 Sinusoidal, Nonsinusoidal, Balanced, or Unbalanced Conditions. IEEE Std 1459-2010
35 (Revision of IEEE Std 1459-2000). Publication Year: 2010 , Page(s): 1 – 50.
- 36 [45] Smart Grids European Technology Platform, <http://www.smartgrids.eu/>.
- 37 [46] A. Camacho, M. Castilla, J. Miret, J.C. Vasquez, and E. Alarcón-Gallo, "Flexible Voltage
38 Support Control for Three-Phase Distributed Generation Inverters Under Grid Fault,"
39 IEEE Trans. on Industrial Electronics, vol. 60, no. 4, pp. 1429-1441, 2013.
- 40 [47] Y. Ueda, K. Kurokawa, T. Tanabe, K. Kitamura, and H. Sugihara, "Analysis Results of
41 Output Power Loss Due to the Grid Voltage Rise in Grid-Connected Photovoltaic
42 Power Generation Systems," IEEE Trans. on Industrial Electronics, vol. 55, no. 5, pp.
43 2744-2751, 2008.
- 44 [48] A. Cagnano, E. Tuglie, M. Liserre, and R.A. Mastromauro, "Online Optimal Reactive
45 Power Control Strategy of PV Inverters," IEEE Trans. on Industrial Electronics, vol. 58,
46 no. 10, pp. 4549-4558, 2011.
- 47 [49] J.C. Vasquez, R.A. Mastromauro, J.M. Guerrero, and M. Liserre, "Voltage Support
48 Provided by a Droop-Controlled Multifunctional Inverter," IEEE Trans. on Industrial
49 Electronics, vol. 56, no. 11, pp. 4510-4519, 2009.
- 50 [50] X. Wang, F. Zhuo, J. Li, L. Wang, and S. Ni, "Modeling and Control of Dual-Stage High-
51 Power Multifunctional PV System in d-q-o Coordinate," IEEE Trans. on Industrial
52 Electronics, vol. 60, no. 4, pp. 1556-1570, 2013.
- 53 [51] E. Romero-Cadaval, M.I. Milanés-Montero, E. González-Romera, and F. Barrero-
54 González, "Power Injection System for Grid-Connected Photovoltaic Generation

- 1 Systems Based on Two Collaborative Voltage Source Inverters,” IEEE Trans. on
2 Industrial Electronics, vol. 56, no. 11, pp. 4389-4398, 2009.
- 3 [52] D. Barater, G. Buticchi, E. Lorenzani, and C. Concari, “Active Common-Mode Filter for
4 Ground Leakage Current Reduction in Grid-Connected PV Converters Operating With
5 Arbitrary Power Factor,” IEEE Trans. on Industrial Electronics, vol. 61, no. 8, pp. 3940-
6 3950, 2014.
- 7 [53] E. Romero-Cadaval, A. Moreno-Muñoz, J.J. González de la Rosa, V.M. Miñambres-
8 Marcos, R.J. Real-Calvo, and José María Sierra-Fernández, “Active Functions
9 Implementation in Smart Inverters for Distributed Energy Resources,” 8th
10 International Conference on Compatibility and Power Electronics (CPE’13), pp. 52-57,
11 2013.
- 12 [54] Q.-C. Zhong and G. Weiss, “Static synchronous generators for distributed generation
13 and renewable energy,” Proc. IEEE PES Power Syst. Conf. Exhib., pp. 1-6, 2009.
- 14 [55] L. Zhang, L. Harnefors, and H.P. Nee, “Power-Synchronization Control of Grid-
15 Connected Voltage-Source Converters,” IEEE Trans. on Power Systems, vol. 25, no. 2,
16 pp. 809-820, 2010.
- 17 [56] Q.-C. Zhong, and G. Weiss, “Synchronverters: Inverters that mimic synchronous
18 generators,” IEEE Trans. on Industrial Electronics, vol. 58, no. 4, pp. 1259-1267, 2011.
- 19 [57] A. E. Fitzgerald, C. Kingsley, and S. D. Umans, “Electric Machinery,” McGraw-Hill, 2003.
- 20 [58] J. H. Walker, “Large Synchronous Machines: Design, Manufacture and Operation,”
21 Oxford Univ. Press, 1981.
- 22 [59] P. Kundur, “Power System Stability and Control,” McGraw-Hill, 1994.
- 23 [60] L. Harnefors, M. Bongiorno, and S. Lundberg, “Input-admittance calculation and
24 shaping for controlled voltage-source converters,” IEEE Trans. Ind. Electron., vol. 54,
25 no. 6, pp. 3323-3334, 2007.
- 26 [61] D. Jovcic, L. Lamont, and L. Xu, “VSC transmission model for analytical studies,” Proc.
27 IEEE Power Eng. Soc. Gen. Meet., vol. 3, pp. 1737-1742, Jul. 2003.
- 28 [62] Q.-C. Zhong, P.-L. Nguyen, Z. Ma; W. Sheng, “Self-Synchronized Synchronverters:
29 Inverters Without a Dedicated Synchronization Unit,” IEEE Trans. on Power
30 Electronics, vol.29, no.2, pp.617-630, 2014.
- 31 [63] J Kolar, J. Biela, Waffer, T. Friedli, and U. Badstubner, “Performance Trends and
32 Limitations of Power Electronic Systems.” 6th International Conference on Integrated
33 Power Electronics Systems (CIPS 2010), Nuremberg, Germany, 2010.
- 34 [64] S. Kouro, M. Malinowski, K. Gopakumar, J. Pou, L.G. Franquelo, B. Wu, J. Rodriguez, M.
35 Perez, and J.I. Leon, “Recent Advances and Industrial Applications of Multilevel
36 Converters,” IEEE Trans. on Industrial Electronics, vol. 57, no. 8, pp. 2553-2580, 2010.
- 37 [65] H. Abu-Rub, M. Malinowski, and K. Al-Hadad, “Power Electronics for Renewable
38 Energy Systems, Transportation and Industrial Applications,” John Wiley&Sons, 2014
39 (Chapter 4, J. Rąbkowski, D. Pefitisis, H.P. Nee “Recent Advances in Power
40 Semiconductor Technology”).
- 41 [66] R. Burkart, and J. W. Kolar “Comparative Evaluation of SiC and Si PV Inverter Systems
42 Based on Power Density and Efficiency as Indicators of Initial Cost and Operating
43 Revenue,” 14th IEEE Workshop on Control and Modeling for Power Electronics
44 (COMPEL 2013), 2013.
- 45 [67] A. Bidram, A. Davoudi, and R. S. Balog, “Control and Circuit Techniques to Mitigate
46 Partial Shading Effects in Photovoltaic Arrays,” IEEE Journal of Photovoltaics, vol. 2,
47 NO. 4, pp. 532-545, 2012
- 48 [68] L. Asiminoaei, P. Rodriguez, F. Blaabjerg, and M. Malinowski “Reduction of Switching
49 Losses in Active Power Filters With a New Generalized Discontinuous-PWM Strategy,”
50 IEEE Trans. on Industrial Electronics, Vol. 55, No. 1, pp. 467-471, 2008.
- 51 [69] F. Blaabjerg. “Power Electronics in Renewables – Status and Perspective,” The 3rd
52 Seminar Power Electronics in Renewable Energy Sources and Drives, Warsaw, Poland,
53 2013.

- 1 [70] A. Vezzini, and F. Baumgartner, "Latest in PV Inverter & Trends,"
2 [https://home.zhaw.ch/~bauf/pv/talks/120326 Trends PV Inverter photon bauf v](https://home.zhaw.ch/~bauf/pv/talks/120326_Trends_PV_Inverter_photon_bauf_via1.pdf)
3 [ia1.pdf](https://home.zhaw.ch/~bauf/pv/talks/120326_Trends_PV_Inverter_photon_bauf_via1.pdf).
- 4 [71] H.-P. Beck, and R. Hesse, "Virtual synchronous machine," in Proc. 9th Int. Conf. EPQU,
5 pp. 1–6, 2007.
- 6 [72] J. Driesen, and K. Visscher, "Virtual synchronous generators," in Proc. IEEE Power
7 Energy Soc. Gen. Meeting–Conversion and Delivery of Electrical Energy in the 21st
8 Century, pp. 1–3, 2008.
- 9 [73] K. Visscher, and S. W. H. De Haan, "Virtual synchronous machines (VSG's) for
10 frequency stabilisation in future grids with a significant share of decentralized
11 generation," in Proc. IET-CIRED Semin. Smart-Grids Distrib., pp. 1–4, 2008.
- 12 [74] C. Sao, and P. Lehn, "Autonomous load sharing of voltage source converters," IEEE
13 Trans. Power Delivery, vol. 20, no. 2, pp. 1009–1016, 2005.
- 14 [75] J. Vasquez, J. Guerrero, A. Luna, P. Rodriguez, and R. Teodorescu, "Adaptive droop
15 control applied to voltage-source inverters operating in grid-connected and islanded
16 modes," IEEE Trans. Industrial Electronics, vol. 56, no. 10, pp. 4088–4096, 2009.
- 17 [76] Q.-C. Zhong, "Robust droop controller for accurate proportional load sharing among
18 inverters operated in parallel," IEEE Trans. on Industrial Electronics, vol. 60, no. 4, pp.
19 1281–1290, 2013.
- 20 [77] M. Ashabani and Y. A.-R. I. Mohamed, "Novel Comprehensive Control Framework for
21 Incorporating VSCs to Smart Power Grids Using Bidirectional Synchronous-VSC,"
22 IEEE Trans. on Power System, vol. 29, no. 2, pp. 943–957, 2014.