



HAL
open science

Effect of welding parameters on the quality of multilayer deposition of aluminum alloy

Arturo Gomez Ortega, Luis Corona Galvan, Sébastien Rouquette, Frédéric Deschaux-Beaume

► To cite this version:

Arturo Gomez Ortega, Luis Corona Galvan, Sébastien Rouquette, Frédéric Deschaux-Beaume. Effect of welding parameters on the quality of multilayer deposition of aluminum alloy. *Advances in Materials & Processing Technologies Conference*, Dec 2017, Vellore, India. hal-01909063

HAL Id: hal-01909063

<https://hal.science/hal-01909063>

Submitted on 30 Oct 2018

HAL is a multi-disciplinary open access archive for the deposit and dissemination of scientific research documents, whether they are published or not. The documents may come from teaching and research institutions in France or abroad, or from public or private research centers.

L'archive ouverte pluridisciplinaire **HAL**, est destinée au dépôt et à la diffusion de documents scientifiques de niveau recherche, publiés ou non, émanant des établissements d'enseignement et de recherche français ou étrangers, des laboratoires publics ou privés.

Effect of welding parameters on the quality of multilayer deposition of aluminum alloy

A. Gómez Ortega, L. Corona Galvan, F. Deschaux-Beaume, S.
Rouquette

LMGC, Univ. Montpellier, CNRS, Montpellier, France,

e-mail: arturo.gomez-ortega@umontpellier.fr

Keywords: Additive manufacturing, Cold Metal Transfer, Welding, Aluminum Alloy, Wire.

Abstract. Nowadays amongst additive manufacturing (AM) technologies, the Wire and Arc Additive Manufacturing (WAAM), process that uses metallic wire as filler and an arc welding process as a fusion source, is promising especially because of its high deposition rate, low cost raw materials, low material loss, and capability to manufacture large parts with an automatized system. On the other hand, the aluminum is a frequently used material in the industry, principally because its low density and mechanical properties, what make it interesting to be employed by AM processes. The present study focuses on the implementation of a Cold Metal Transfer (CMT) welding generator using an aluminum alloy wire (Al5Si) for AM applications. CMT process is a promising one for WAAM, thanks to its controlled current waveform and filler wire feeding that allow regular deposited weld beads.

The aim of this work is to identify the relationships between the CMT welding parameters and the physical characteristics of deposited metal, in order to find the most suited parameters allowing a regular deposit. The CMT work parameters were evaluated in order to observe its effects on the morphological aspect of the deposited weld beads. Construction of multilayer metallic walls is achieved, and the presence of geometrical defects that could affect the correct wall formation was identified when the deposit is not continuous, with many ignition and stop cycles. Some propositions to decrease the presence of these defects are tested. Attempts of multi layers addition are presented, and relationship between these last results and CMT parameters is discussed.

1. Introduction

The additive manufacturing (AM) technologies for metallic parts production are a promising way to build near-net shaped objects. Compared to traditional machining processes, they offer advantages like the high value of the buy-to-fly ratio and the manufacturing lead-time [1]. Nowadays, various AM techniques have been developed for manufacturing metallic parts, such as selective melting technologies [2], electron beam melting [3], and direct energy deposition (DED) [4]. The DED technologies based on powder projection or filler wire melting are characterized by a higher deposition rate and suitability for big components fabrication. They can use as melting source a laser beam [5], a plasma [6] or an electrical arc [7].

Arc welding based AM (WAAM) is a DED technique that uses metallic wire as filler and an arc welding process as melting source. Between the various advantages of this process, one can mention the lower cost in raw material, and a higher deposition rate [8]. Among the various arc welding processes that can be used for the wire melting, the cold metal transfer (CMT) process seems to be a suitable option for this AM technique, thanks to its simultaneous control of the current and the filler wire feeding to obtain regular deposited weld beads [9].

The utilization of aluminum alloys and the CMT generator for AM has already been presented in some previous studies [10, 11], where a comparison of the effect of the use of various CMT variants (CMT, CMT Pulsed, CMT Advanced and CMT Pulsed-Advanced) on multilayer deposition characteristics was carried on. However, the use of aluminum alloys with these processes is still rather rare compared to steel and titanium alloys [9, 12, 13]. On the other hand, the CMT configurations are well defined for welding process, but these configurations are not defined to the specific cases of multilayer construction, and only few studies are dedicated to the understanding and optimization of the CMT process parameters configurations for such applications [14, 15].

The present work constitutes a foundation in the analysis of the effects of some CMT parameters on the multilayer deposition of weld beads for AM, taking as principal reference a previous study made by the same research team [16].

2. Experimental details

The experimental study consists in the characterization of multilayer deposits obtained by WAAM technique. This evaluation involves the analysis of the pre-recorded process parameters, and the measure of the geometrical characteristics of the deposits.

An advanced variation of a Gas Metal Arc Welding source, known as Cold Metal Transfer of Fronius, is used to control the melting process of the wire. The filler wire used is a standard aluminum alloy wire for arc welding (1.2 mm Al5Si wire, similar to ER4043 according to AWS). The deposits were

achieved with a dedicated 3D system developed for the study of WAAM process. It consists of a three-axis worktable with a fixed CMT welding torch (Figure 1).

The CMT process is used in one of its conventional configurations dedicated to the specific filler wire used (1.2 mm Al5Si wire), with a 100% Argon shielding gas. A CMT configuration is composed of 15 combined main parameters that control the melting and the deposit of the metal. In this study, only the effect of some parameters corresponding to the deposit phase is investigated. The deposit phase is controlled by only 8 parameters that defined the current and voltage waveforms of the CMT process cycle (Figure 2).

In order to record the electric parameters during all the deposit, the worktable is instrumented with a Hall effect transducer (LEM LF 305-S) and voltage dividers to measure the process current and voltage. Both are recorded at a 25-kHz frequency. To have a better understanding of the melting process, a high-speed camera (Phantom ir300) was used to record videos of the filler wire tip during the deposits, at 2200 images per second.

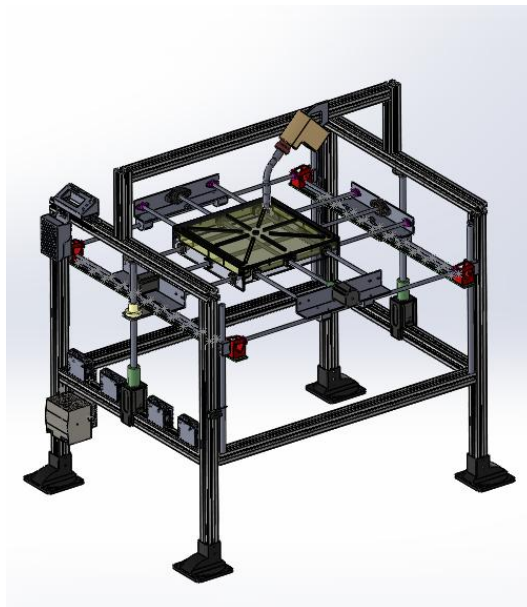

Figure 1 Representation of the 3D device developed for the study

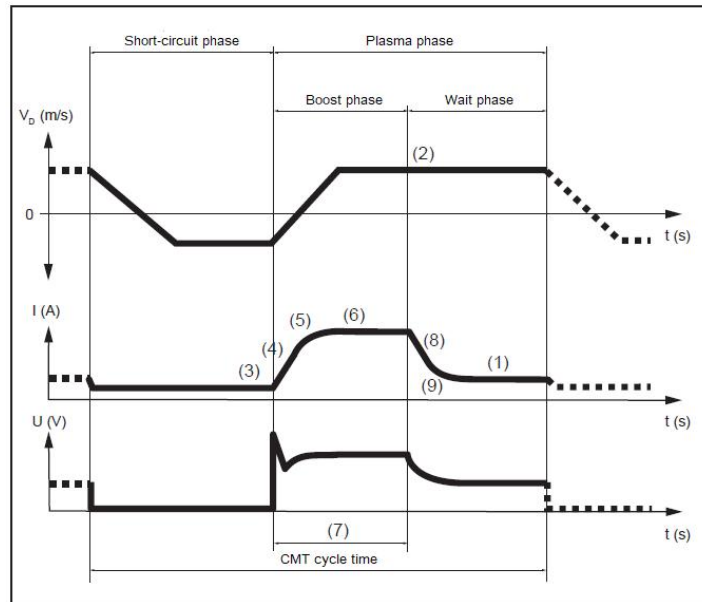

Figure 2 Schematic representation of the current (I) and voltage (U) waveforms and of the feeding rate (Vd) variation during a CMT cycle during the deposit phase.

The tests were made by depositing successive beads of 150 mm length on a 3 mm thick substrate of 1050 aluminum alloy. A pause of 10 seconds was imposed between each layer deposition to have a partial cooling of the deposited material. At the beginning of every deposit, a distance of 15 mm between the torch and the work plate was measured. After the first bead, the plate comes down 1 millimeter between each new deposit, this value being the average layer height estimated from previous measures with monolayer and multilayer deposits. The deposition procedure is shown in the figure 3.

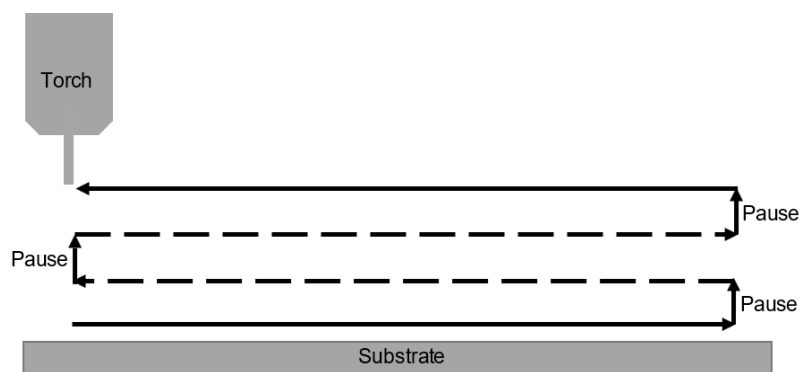

Figure 3 Deposition procedure

In order to analyze geometrical parameters of the deposits, each sample was scanned using a Breuckmann 3D scan to obtain a STL representation that was treated with the Geomagic commercial software and a dedicated Python script. Geomagic software is used to align every 3D recovered

representation to a common orientation for the posterior Python handling. It is also used to calculate the volume of the deposits, taken to deduce the deposited mass, supposing the aluminum density equal to 2700 kg/m^3 . The Python routine imports the STL files and extracts different deposit contours to be measured. The height is estimated by considering 130 cross sections measured each millimeter along the deposit, ignoring the beginning and the end parts that normally show irregularities (Figure 4). The width is calculated by a variable number of longitudinal sections parallel to the plate surface, that depend of the height previously measured, having a minimum of 10 considered sections (Figure 5). The average and standard deviation of both parameters were computed for the analysis.

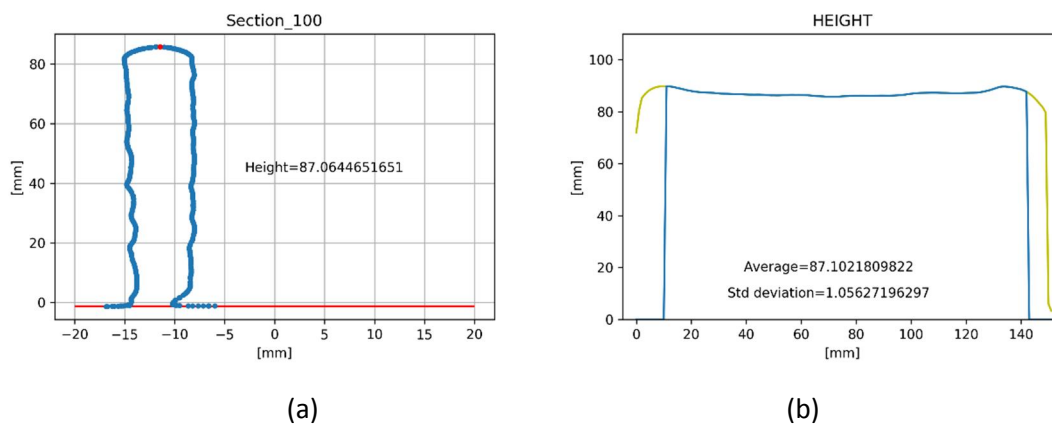

Figure 4 Cross section for height measuring (a), and variation of measured height in the various cross sections along a multilayer deposit (b)

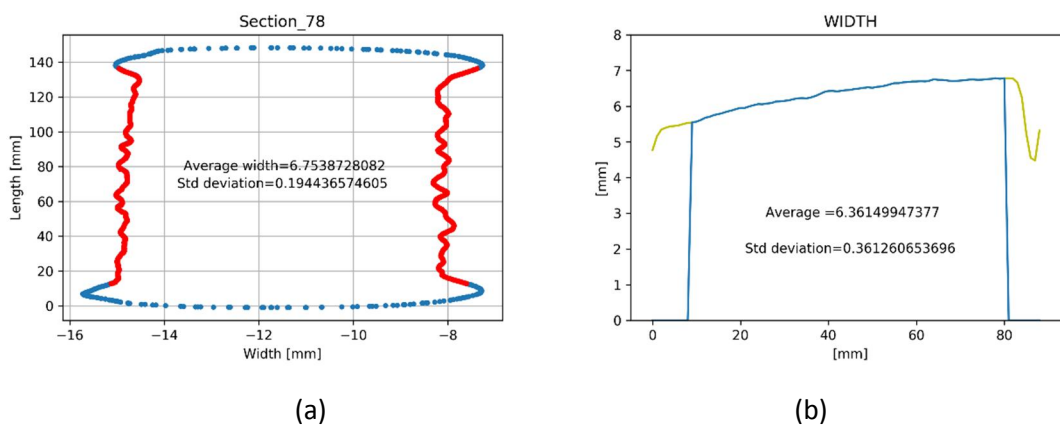

Figure 5 Longitudinal section parallel to the plate surface for width measuring (a), and variation of measured average width according to the location of the longitudinal section on the height of the deposit (b)

First multilayer deposits samples were carried using the standard process parameters pre-recorded in the welding station for an Al5Si filler wire (Table 1), varying the number of layers, with three

different travel speeds of 600, 1200 and 2400 mm/min. A second test campaign was then achieved to build samples using a constant travel speed of 900 mm/min, and varying some CMT cycle parameters to improve the sample geometry (Table 2).

Table 1: Pre-recorded process parameters of the CMT, and associated average power.

	I_{sc_wait} (A)	v_d (m.min ⁻¹)	I_{sc} (A)	$d_{boostup}$ (A.ms ⁻¹)	$t_{boostup}$ (ms)	I_{boost} (A)	t_{boost} (ms)	$d_{boostdown}$ (A.ms ⁻¹)	Average power (W)
P5	70	25	40	300	0.1	150	2	300	1039
P6	70	35	40	300	0.1	150	5	300	1470
P7	70	37,5	40	300	0.1	135	9,5	300	1666

Table 2: Parameters retained for the second test campaign

Sample	Configuration point	Modification	Layers number	Pause [s]
1	P5		60	15
2	P5		30	15
3	P6		25	15
4	P7		25	15
5	P5	$d_{boostdown} = 10$ [A/ms]	30	15
6	P5	$d_{boostdown} = 25$ [A/ms]	30	15
7	P5	$t_{I_boost} = 3.5$ [ms]	30	15
8	P5	$t_{I_boost} = 5$ [ms]	30	15
9	P5	$v_{d_sc_wait} = 10$ [m/min]	30	15

3. Results

In first multilayer deposits with standard process parameters, the stability of the CMT process was analyzed by observing the time duration of the three CMT phases (Figure 2): the boost phase, corresponding to the current pulse; the wait phase, corresponding to the feeding of the filler wire towards the substrate, under a lower arc current; and finally, the short-circuit phase, corresponding to the contact of the wire with the substrate, allowing the deposit of a liquid metal drop. It is notable that the average time duration stayed regular but not constant with the addition of layers (Figure 6). There is a slight variation in the Wait and Short-circuit phases durations, related to a variation in the distance between the contact tube in the torch and the deposited bead. Since this parameter is not a CMT monitored variable, the process was automatized to increase the distance between the substrate and

the welding torch by 1 mm after each deposited layer, without considering the exact variation of height with the layer addition. The biggest variation of these time durations is observable with samples built at 600 mm/min, where the height increment for each layer is more important, and then decreases the distance between the torch and the layer surface. The average power in each deposit remained constant, no matter the number of layers or the travel speed used (Figure 7). However, the small variations in the time durations of the cycle modify directly the deposit rate and the average weight of each deposited drop. These variations could have an important effect into the quantity of material added each layer.

The evolution of the geometric characteristics of the deposits show that during the continuous addition of layers, with a constant heat power, contrary to the desire conditions to the additive manufacturing, the width of the deposits increase due to the heat accumulation and the re-melting of the previous layers (Figures 8 and 9). If this width variation is not regulated it could represent a limitation to the accuracy of the building parts by this technique. A steady deposit width appears when a bigger number of the layers is added (Figure 11). In specific this regularity is notorious after the 8th layer, then a difference of 0.3 mm (less than 10% of the average's width) is found between 8 layers and a 32 layers deposit. The height evolution is also irregular, but it seems to arrive easily to a linear behavior when higher speeds and number of layers are used (Figure 11.a).

As we expected, thinner walls were able to build through constant deposit rate with the increment of the travel speed. However, this did not show an important height's offset between the deposits, even though it was used 3 different CMT configurations. The evolution in the geometry of the deposit is easily perceptible in the width, which confirms that electric power has an important influence on the thickness of the deposited wall, as it can be seen in Figures 8 and 9. The standard deviation measured was around 0.25 for the height and 0.35 for the width, it could be good enough for the height, but it is not for the width.

The second part of the study concerns the improvement of the geometric characteristics of multilayer deposits by the variation of CMT parameters from a CMT standard configuration giving unregular deposits.

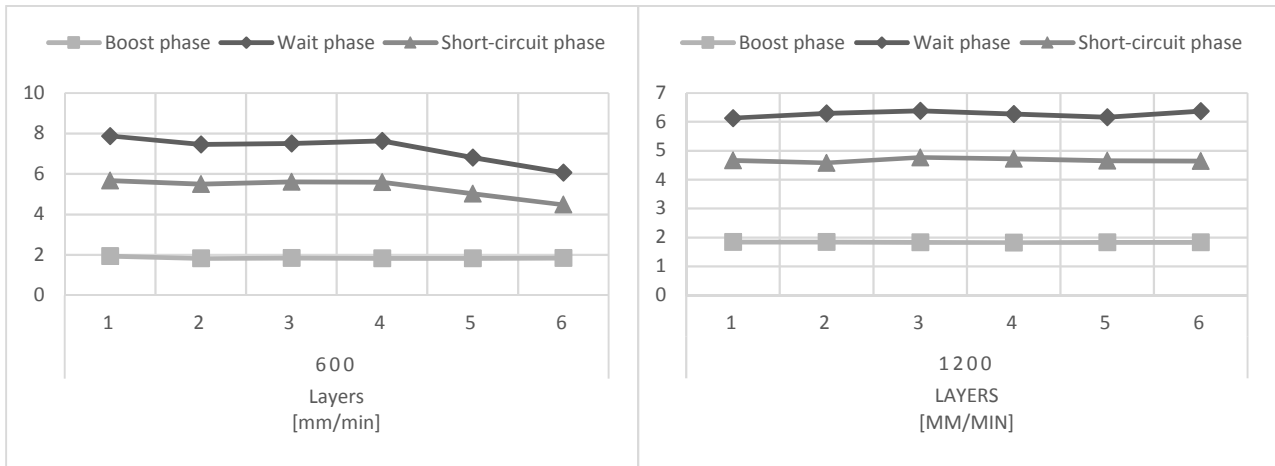

Figure 6 Average time duration of CMT cycle phases for samples made with configuration point P5

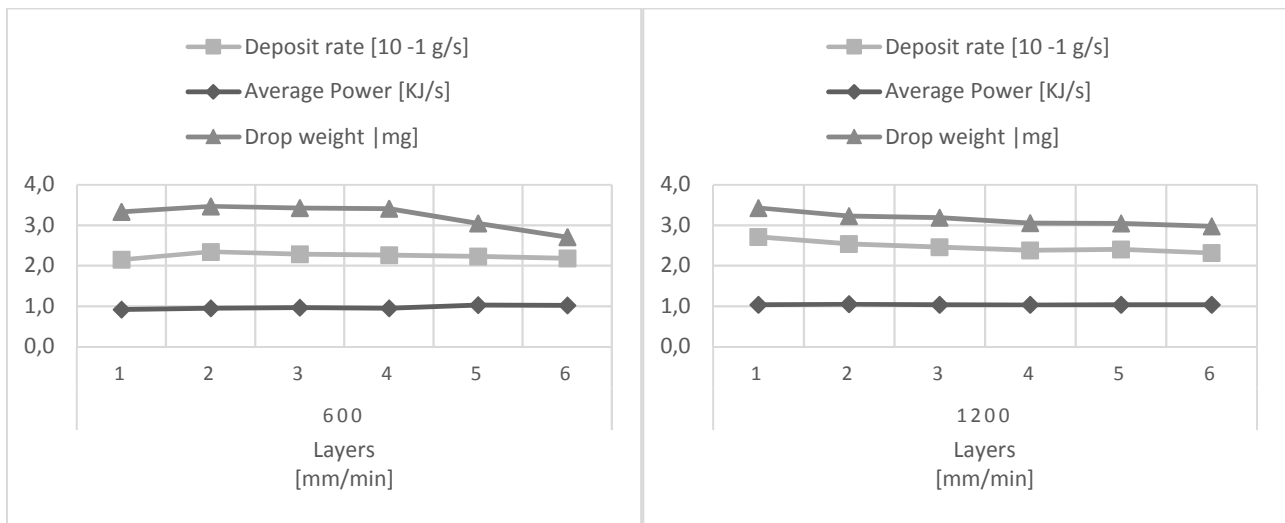

Figure 7 Characteristics of the metal transfer with configuration point P5

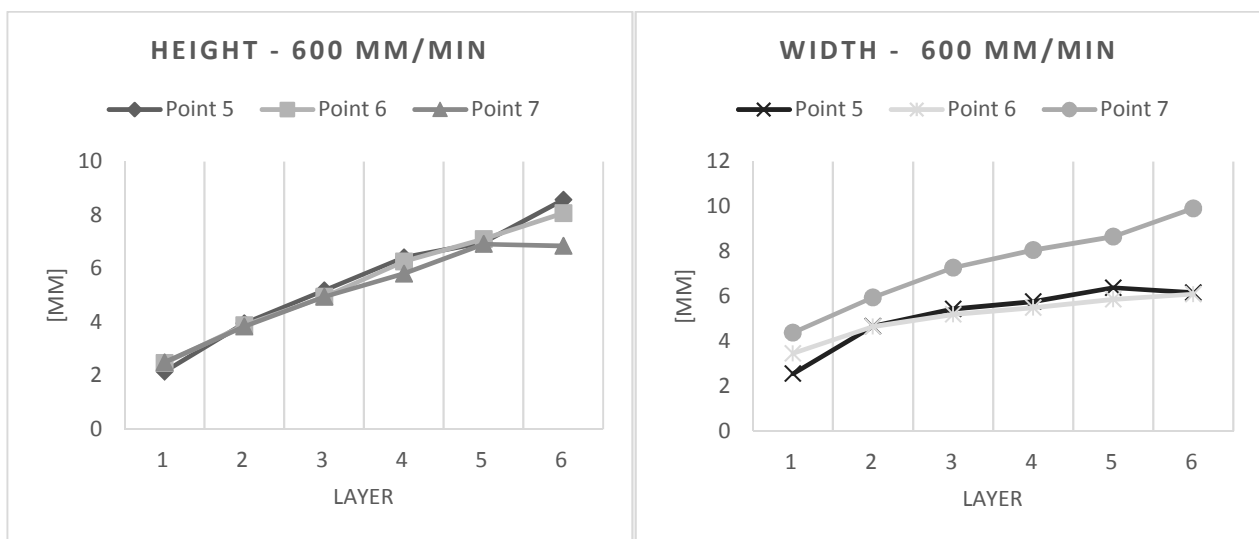

Figure 8 Geometric characteristics of multilayer deposits at 600 mm/min

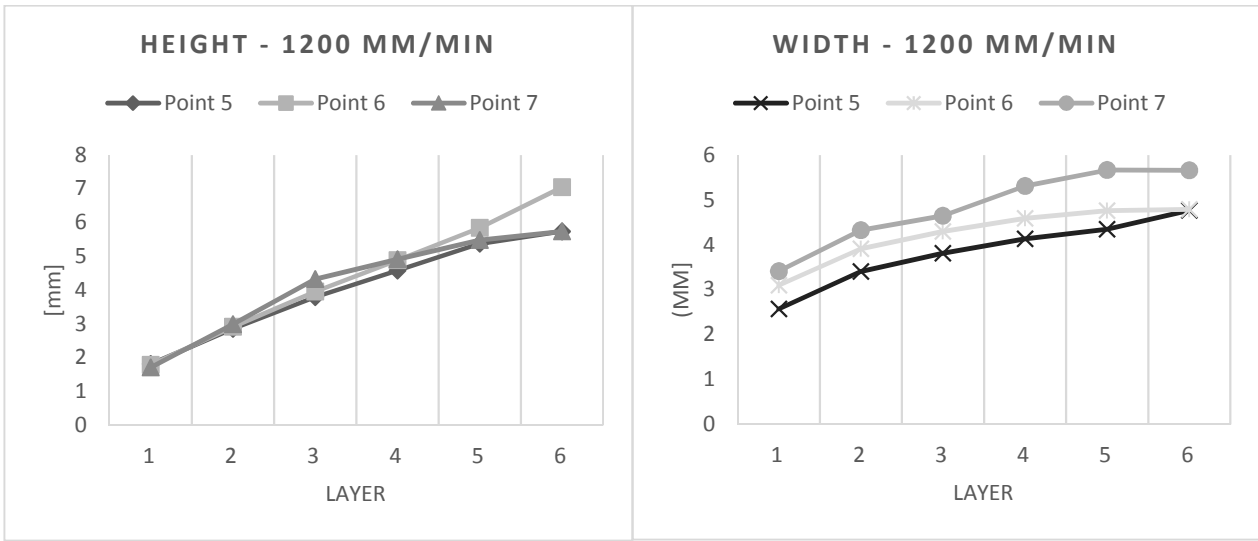

Figure 9 Geometric characteristics of multilayer deposits at 1200 mm/min

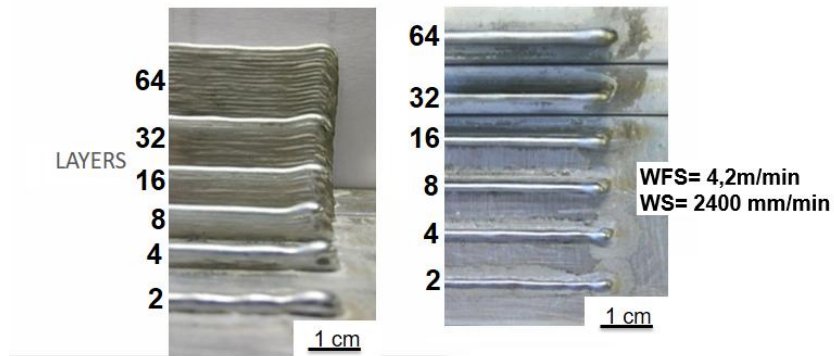

Figure 10 Example of Multilayer deposits

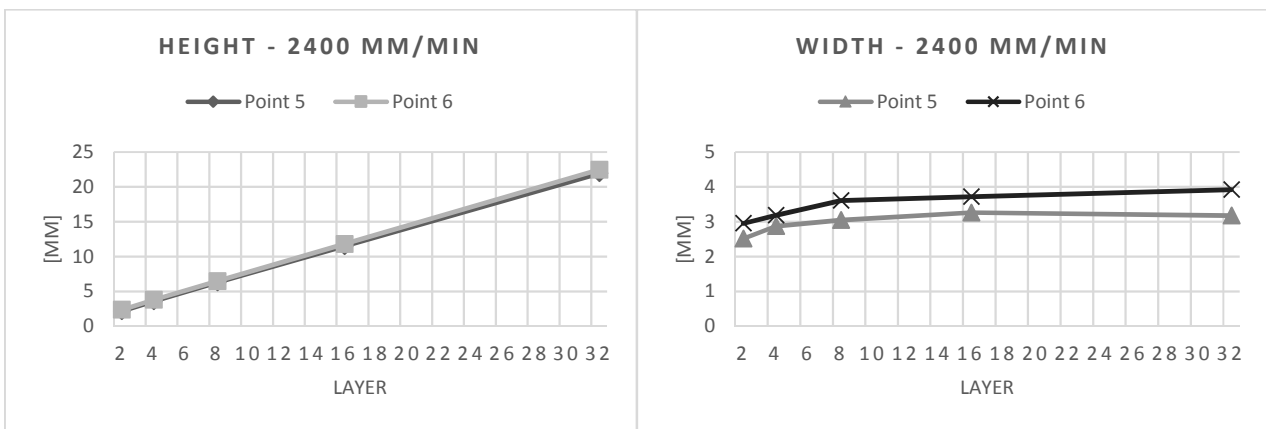

Figure 11 Geometric characteristics of multilayer deposits at 1200 mm/min

The standard configuration point retained as reference is configuration “P5” with a travel speed of 900 mm/min, that gives unregular wall height (Figure 12). It was found that during the first 10 layers deposited with these constant parameters, an irregular weld bead deposit takes place, similar to the welding defect well-known as “humping”, that is characterized by discontinuous weld beads. This defect is generally related to low energy contribution from the melting source and to high travel speeds. In this case a particular behavior was identified: after the irregularity formation in the first 10 layers, the deposit became regular enough to maintain the waved form, generated from the beginning to the end of the wall construction, apparently regardless the number of layers (Figure 12). However, between the 30th and the 60th layers, a correction of this geometrical defect seems to appear at the beginning and the end of the wall (Figure 12a).

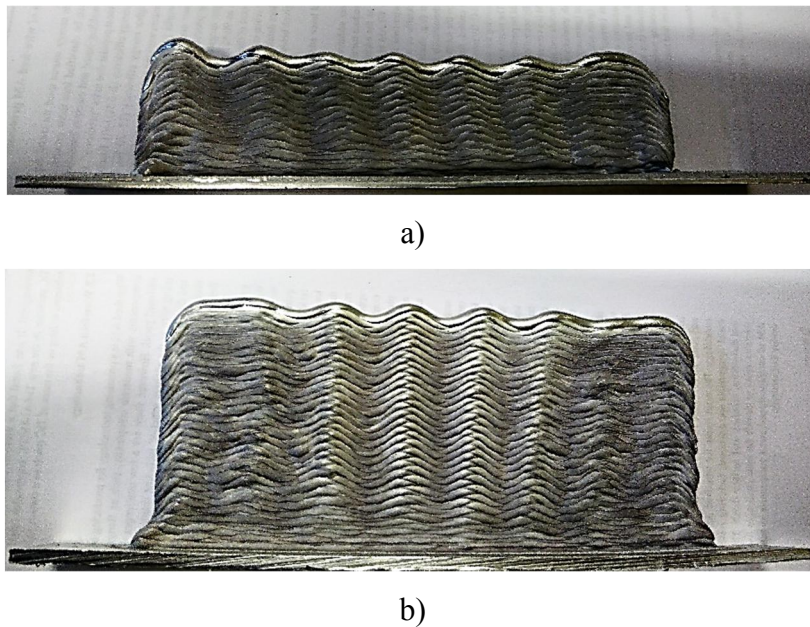

Figure 12 *Geometrical defect in multilayer walls obtained with configuration point P5 with a travel speed of 900 mm/min a) after 30 layers b) after 60 layers*

The study was lead to modify some CMT parameters to change the electric power contribution in different ways, and to identify the influence of this parameters to improve the geometry of the multilayer deposit. These “optimized” parameters were studied previously and identified as good modifiers of the deposit process [16]. The modified parameters retained to improve the walls geometry are resumed in table 2. The effects of these parameter modifications on the time duration of the three CMT cycle phases are given in figure 13. These modifications have a significant effect on the average power and the metal transfer, i.e. the deposit rate and the deposited drop weight (Figure 14). The resulting effetc of these modifications on the width and height of the walls are presented in table 3, with the order marked in Table 2. First, two wall samples corresponding to the irregular walls

obtained with the reference parameters (P5 with a travel speed of 900 mm/min) are shown in figure 12 and table 3 (samples 1 and 2).

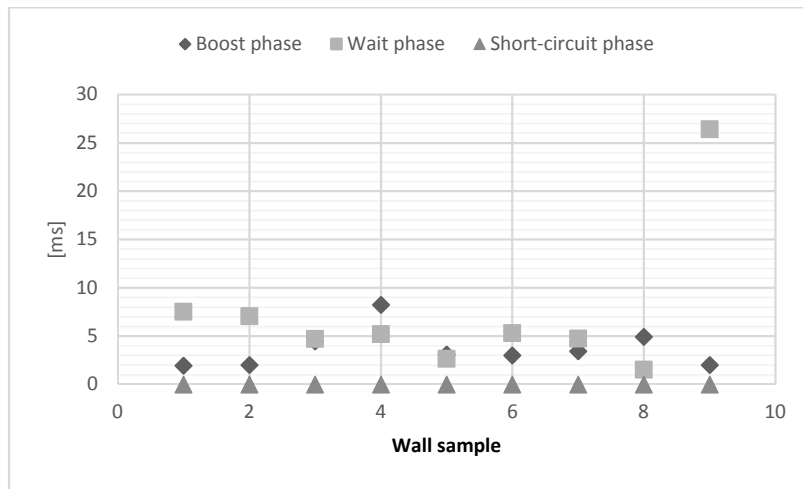

Figure 13 Average time duration of the CMT phases for the 9 modified configuration of table 2

The next two multilayer wall samples (3 and 4 on table 3) were achieved by using the CMT configuration points P6 and P7. These configuration points are different from the configuration P5 for having a bigger average electric power contribution in the process, higher deposit rate and drop weight, that will clearly modify the geometry. As expected (Figure 9), deposit with energetic configuration P6 and P7 are thicker than the samples 1 and 2. They don't show the "humping" appearance (Table 3), and it is observable in the standard deviations of wall height and width (Figure 15), the major improvement is reached with the configuration point P6.

The rest of walls were built using the same energetic configuration P5 with a single modification of one of their control parameters. The first parameter to be modified is the "d_boostdown" parameter (wall samples 5 and 6), which controls the current decrease between the boost phase and the wait phase. A decrease of this parameter results in an increase of the boost phase duration (Figure 13), of the average power, and of the deposit rate and drop weight (Figure 14), Concerning the wall geometry, sample 5 has a more regular height than the reference walls (samples 1 and 2), as indicated by the lower height standard deviation, but the width regularity is not improved (Figure 15). The wall geometry on sample 6 is not improved, the height standard deviation as well as the amplitude of waves formed by humping being increased compared to reference samples (Figure 15 and Table 3). Next modifications were made by changing the "t_I_boost" parameter that control the duration of the boost phase. It was increased in order to give more power contribution during the boost phase. This modification results in an increase of the deposit rate and of the average electric power. Concerning the geometry, sample 7 don't show valuable results, the humping effect being increased in

comparison with reference samples. In sample 8, the height regularity is improved, probably due to the higher average power, which promotes the wetting, and a width increase, reaching 8 mm (Figure 15 and Table 3).

The last parameter modified was the “vd” parameter, corresponding to the feeding speed of the wire during the wait phase. This parameter was decreased to 10 m/min, in order to give more time to the wait phase. This change didn’t increase the power contribution but allows the formation of bigger drops (Figure 14). This sample geometry (sample 9) shows a very good accuracy on the width, but the height is not improved (Figure 15 and Table 3). However, the big problem of this configuration was that it promotes the presence of spatter during the deposit. Finally, measures show that the geometry was really improved with the utilization of the configuration P6 instead of P5.

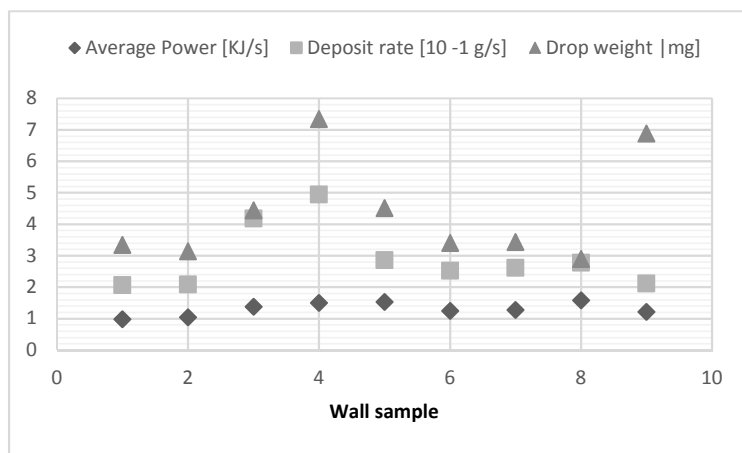

Figure 14 Effect of parameters variation given in table 2 on the average power and metal transfer.

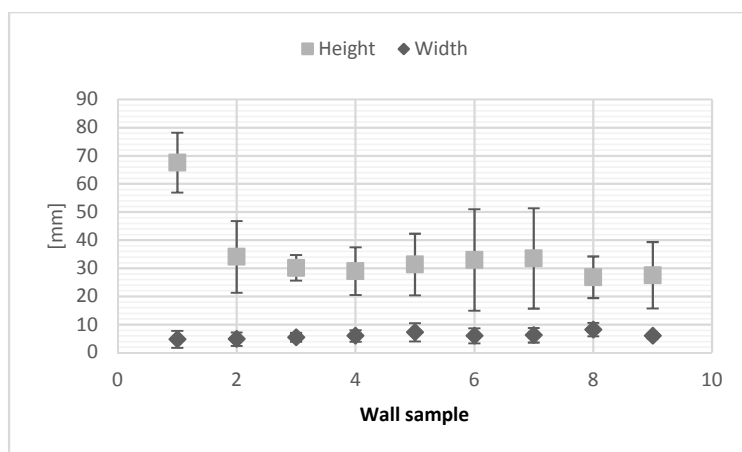

Figure 15 Evolution of the average of width and height of the multilayer deposits with parameters variation. Standard deviations were multiplied by 10 to be visible.

Table 3 Geometric characteristics of the walls obtained with the modified parameters of table 2

Sample / CMT cycle

HEIGHT [mm]

WIDTH [mm]

1

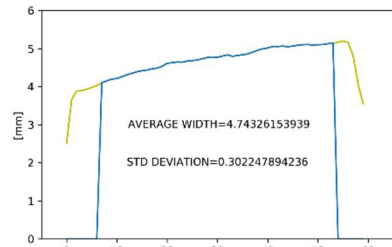
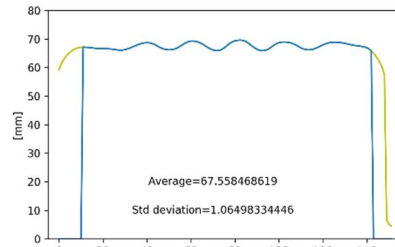
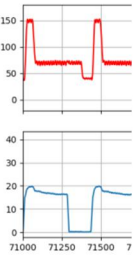

2

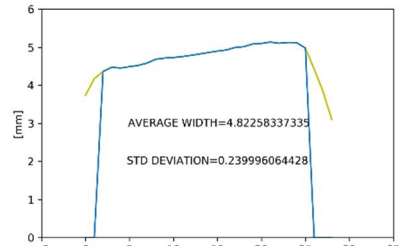
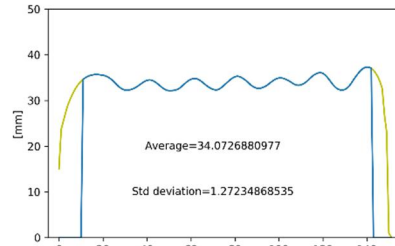
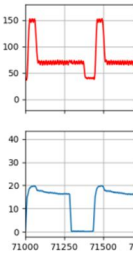

3

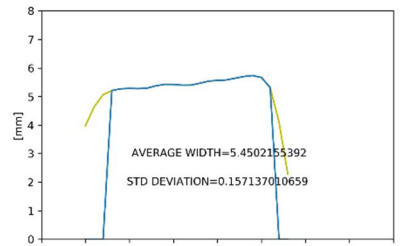
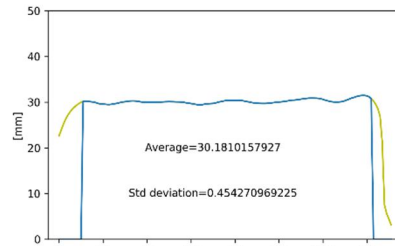
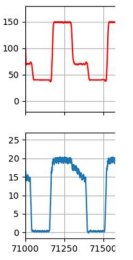

4

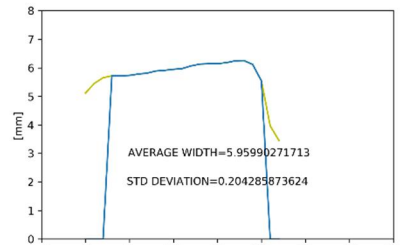
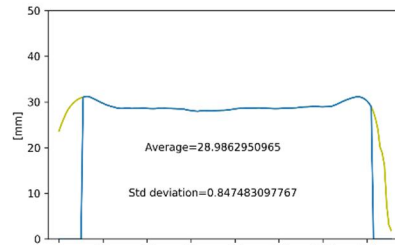
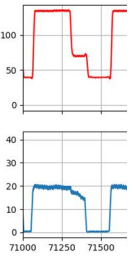

5

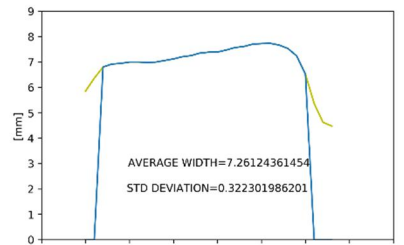
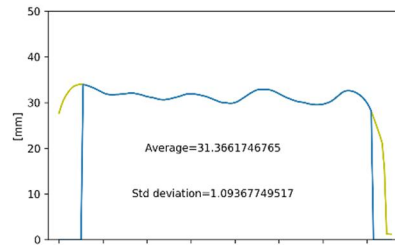
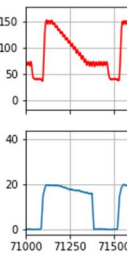

6

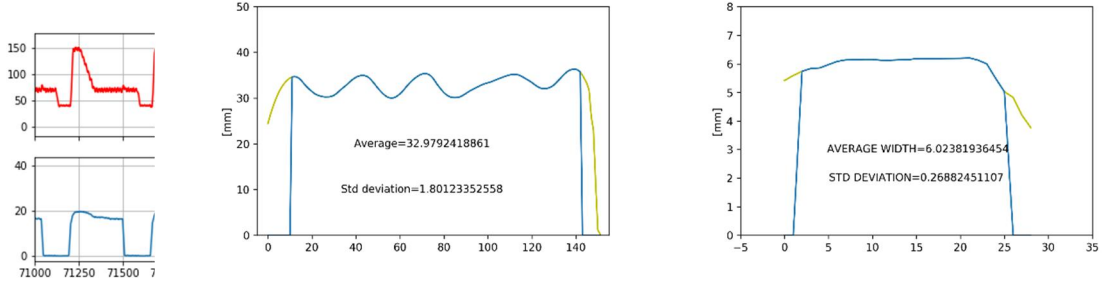

7

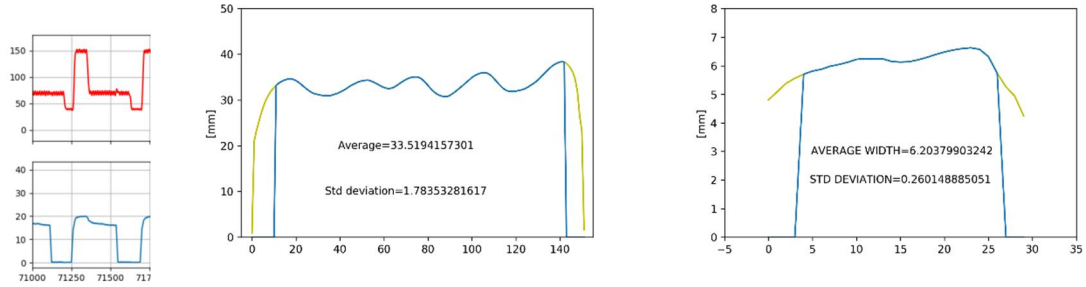

8

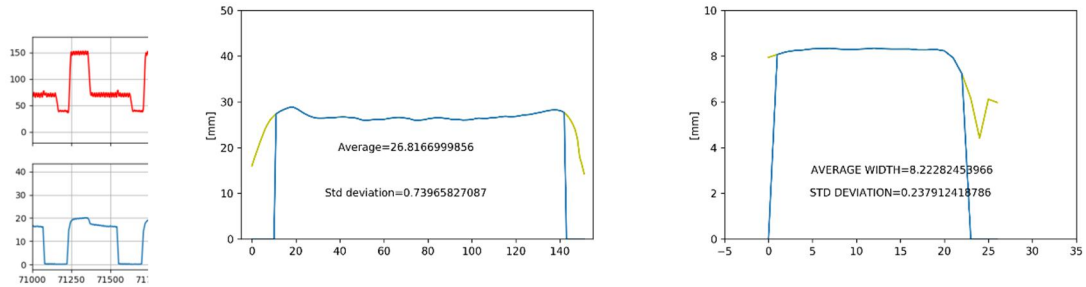

9

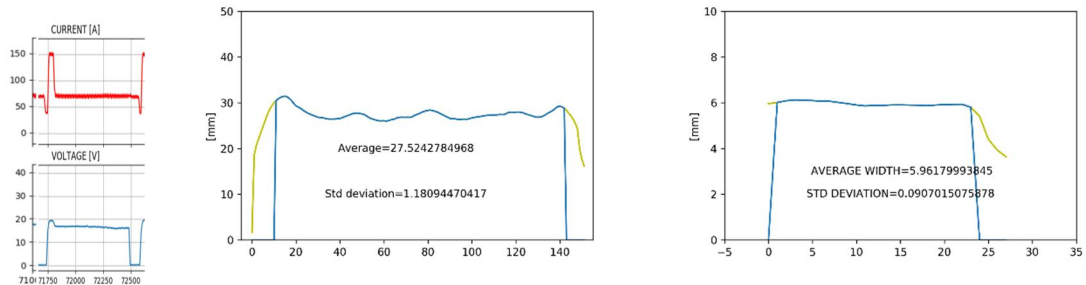

4. Conclusion

The present study of multilayer deposition allowed to identify important parameters to be considered to improve the geometry accuracy of the deposits. As it was observed, it is important to add a monitoring system to control the distance between the contact-tube and the substrate or the precedent weld bead deposited, ensure the stability of the melting source.

In order to improve regularity in multilayer deposits, higher travel speeds are recommended, but it's necessary to evaluate the dimensional requirements from the part, before the fabrication,. It is found that a way to improve the width quality, could be the constant adjustment of the heat source and the working travel speed, to get a constant width on each layer addition.

Finally, the variation of specific CMT parameters shows a big potential to make an optimal adjustment of the heat source. The parameters that modify directly the boost phase had showed a big impact in multilayer deposit when the parameters where modified at the beginning of the deposition process and used all along until the last deposited layer. The study of the effect of the CMT parameters on multilayer deposition must be extended to identify most interesting cases. In conclusion, it is confirmed that the understanding of the CMT parameters leads to the understanding of the metal transfer process, which could be used to control minimal variations of a fixed configuration in order to improve the geometrical characteristics of the multilayer deposit.

References

- [1] G. B. Kannan and D. K. Rajendran, "A Review on Status of Research in Metal Additive Manufacturing," in *Advances in 3D Printing & Additive Manufacturing Technologies*, D. I. Wimpenny, P. M. Pandey, and L. J. Kumar, Eds. Singapore: Springer Singapore, 2017, pp. 95–100.
- [2] "Laser additive manufacturing," *Mechatronic Vehicle Systems Lab*, 08-Apr-2015. [Online]. Available: <https://uwaterloo.ca/mechatronic-vehicle-systems-lab/research/laser-additive-manufacturing>. [Accessed: 14-Sep-2017].
- [3] C. us P. +4631 710 32 00 F. +4631 710 32 01 S. contact form, "Electron Beam Melting - EBM Process, Additive Manufacturing," *Arcam AB*. [Online]. Available: <http://www.arcam.com/technology/electron-beam-melting/>. [Accessed: 27-Feb-2017].
- [4] D. Ding, Z. Pan, D. Cuiuri, and H. Li, "Wire-feed additive manufacturing of metal components: technologies, developments and future interests," *Int. J. Adv. Manuf. Technol.*, vol. 81, no. 1–4, pp. 465–481, Oct. 2015.
- [5] E. Brandl, B. Baufeld, C. Leyens, and R. Gault, "Additive manufactured Ti-6Al-4V using welding wire: comparison of laser and arc beam deposition and evaluation with respect to aerospace material specifications," *Phys. Procedia*, vol. 5, pp. 595–606, 2010.
- [6] H. Zhang, J. Xu, and G. Wang, "Fundamental study on plasma deposition manufacturing," *Surf. Coat. Technol.*, vol. 171, no. 1–3, pp. 112–118, Jul. 2003.
- [7] S. W. Williams, F. Martina, A. C. Addison, J. Ding, G. Pardal, and P. Colegrove, "Wire + Arc Additive Manufacturing," *Mater. Sci. Technol.*, vol. 32, no. 7, pp. 641–647, May 2016.
- [8] S. Carlson, "Wire-based AM vs. Powder-based AM." [Online]. Available: <http://www.sciaky.com/additive-manufacturing/wire-am-vs-powder-am>. [Accessed: 23-Feb-2017].
- [9] P. S. Almeida and S. Williams, "Innovative process model of Ti-6Al-4V additive layer manufacturing using cold metal transfer (CMT)," in *Proceedings of the Twenty-first Annual International Solid Freeform Fabrication Symposium, University of Texas at Austin, Austin, TX, USA*, 2010.
- [10] J. Gu, B. Cong, J. Ding, S. W. Williams, and Y. Zhai, "Wire+ arc additive manufacturing of aluminium," in *Solid Freeform Fabrication Proceedings*, 2014, pp. 451–58.
- [11] B. Cong, J. Ding, and S. Williams, "Effect of arc mode in cold metal transfer process on porosity of additively manufactured Al-6.3%Cu alloy," *Int. J. Adv. Manuf. Technol.*, vol. 76, no. 9–12, pp. 1593–1606, Feb. 2015.
- [12] M. Liberini *et al.*, "Selection of Optimal Process Parameters for Wire Arc Additive Manufacturing," *Procedia CIRP*, vol. 62, pp. 470–474, 2017.

- [13] C. V. Haden, G. Zeng, F. M. Carter, C. Ruhl, B. A. Krick, and D. G. Harlow, "Wire and arc additive manufactured steel: Tensile and wear properties," *Addit. Manuf.*, vol. 16, pp. 115–123, Aug. 2017.
- [14] C. G. Pickin, S. W. Williams, and M. Lunt, "Characterisation of the cold metal transfer (CMT) process and its application for low dilution cladding," *J. Mater. Process. Technol.*, vol. 211, no. 3, pp. 496–502, 2011.
- [15] P. Wang, S. Hu, J. Shen, and Y. Liang, "Characterization the contribution and limitation of the characteristic processing parameters in cold metal transfer deposition of an Al alloy," *J. Mater. Process. Technol.*, vol. 245, pp. 122–133, Jul. 2017.
- [16] A. Gomez Ortega, L. Corona Galvan, F. Deschaux-Beaume, B. Mezrag, and S. Rouquette, "Effect of process parameters on the quality of aluminium alloy Al5Si deposits in wire and arc additive manufacturing using a cold metal transfer process," *Sci. Technol. Weld. Join.*, pp. 1–17, Oct. 2017.