



HAL
open science

Weyl's law for singular Riemannian manifolds

Yacine Chitour, Dario Prandi, Luca Rizzi

► **To cite this version:**

Yacine Chitour, Dario Prandi, Luca Rizzi. Weyl's law for singular Riemannian manifolds. 2019. hal-01902740v4

HAL Id: hal-01902740

<https://hal.science/hal-01902740v4>

Preprint submitted on 8 Nov 2019 (v4), last revised 18 Aug 2023 (v5)

HAL is a multi-disciplinary open access archive for the deposit and dissemination of scientific research documents, whether they are published or not. The documents may come from teaching and research institutions in France or abroad, or from public or private research centers.

L'archive ouverte pluridisciplinaire **HAL**, est destinée au dépôt et à la diffusion de documents scientifiques de niveau recherche, publiés ou non, émanant des établissements d'enseignement et de recherche français ou étrangers, des laboratoires publics ou privés.

Weyl's law for singular Riemannian manifolds

Y. Chitour*, D. Prandi†, L. Rizzi‡

November 8, 2019

Abstract

We study the asymptotic growth of the eigenvalues of the Laplace-Beltrami operator on singular Riemannian manifolds, where all geometrical invariants appearing in classical spectral asymptotics are unbounded, and the total volume can be infinite. Under suitable assumptions on the curvature blow-up, we show how the singularity influences the Weyl's asymptotics and the localization of the eigenfunctions for large frequencies. Our main motivation comes from the construction of singular Riemannian metrics with prescribed non-classical Weyl's law. Namely, for any non-decreasing slowly varying function v (possibly unbounded) we construct a singular Riemannian structure whose spectrum is discrete and satisfies

$$N(\lambda) \sim \frac{\omega_n}{(2\pi)^n} \lambda^{n/2} v(\lambda).$$

This result can be seen as the asymptotic counterpart of the celebrated result of Y. Colin de Verdière [19], fixing a finite part of the spectrum. A key tool in our arguments is a universal estimate for the remainder of the heat trace on Riemannian manifolds, which is of independent interest.

Contents

1	Introduction	2
1.1	The Grushin sphere model	2
1.2	Setting and main results	3
1.3	Quantitative remainder for heat trace asymptotics	5
1.4	Structure of the paper	6
1.5	Other classes of singular structures	6
2	Heat kernel estimates with remainder	8
2.1	Notation and basic definitions	8
2.2	On-diagonal heat kernel estimates	9
2.3	Heat trace bound	12
2.4	Weyl's law with remainder	15
3	Geometric structure at the singularity	16
4	Weyl's asymptotics for singular manifolds	18

*Laboratoire des Signaux et Systèmes, Université Paris-Sud, CentraleSupélec, Gif-sur-Yvette

†CNRS, Laboratoire des Signaux et Systèmes, CentraleSupélec, Gif-sur-Yvette

‡Univ. Grenoble Alpes, CNRS, Institut Fourier, F-38000 Grenoble, France

5	Slowly varying volumes	20
5.1	Exact Weyl’s law for slowly varying volumes	21
5.2	Metrics with prescribed Weyl’s law	24
6	Concentration of eigenfunctions	26
7	Almost-Riemannian structures	27
7.1	Weyl’s law for strongly regular ARS	28
7.2	Examples	30
A	Auxiliary geometric estimates	31
B	Compactness of the resolvent	34

1 Introduction

In spectral geometry, the asymptotic behaviour of the eigenvalues of the Laplace–Beltrami operator on a smooth and compact Riemannian manifold \mathbb{M} is given by the Weyl’s law:

$$\lim_{\lambda \rightarrow \infty} \frac{N(\lambda)}{\lambda^{n/2}} = \frac{\omega_n}{(2\pi)^n} \text{vol}(\mathbb{M}). \quad (1)$$

Here, $N(\lambda)$ is the number of eigenvalues smaller than λ for the Dirichlet Laplacian on a smooth Riemannian manifold \mathbb{M} , possibly with boundary, $\text{vol}(\mathbb{M})$ stands for the Riemannian volume of \mathbb{M} and ω_n is the volume of the n -dimensional Euclidean unit ball.

The study of eigenvalue asymptotics is a rich topic with a long history. The subject has been treated in several setting and with different methods, see for example [32, 33, 49, 13]. In this paper, we focus on Weyl’s-type asymptotics for the Laplace-Beltrami operator of a class of singular Riemannian structures, where all geometric invariants, including the curvature and the volume, can be unbounded when approaching the singularity. In particular, we aim at understanding to which extent the presence of the singularity modifies the Weyl’s asymptotics (1).

1.1 The Grushin sphere model

We first discuss a simple model, emphasizing the peculiarities of our setting and the main differences with existing results. Consider the two-dimensional sphere $\mathbb{S}^2 \subset \mathbb{R}^3$. Let X and Y be the generators of rotations around the x and y axis, respectively. We define a Riemannian structure by declaring X and Y to be orthonormal. These vector fields are collinear on the equator $S = \{(x, y, z) \in \mathbb{S}^2 \mid z = 0\}$, and hence the metric tensor we defined is singular on S (the coefficients of the metric explode). This is an almost-Riemannian structure in the sense of [2, 9]. In cylindrical coordinates (θ, z) on \mathbb{S}^2 , the associated Laplace-Beltrami operator Δ , with domain $C_c^\infty(\mathbb{S}^2 \setminus S)$ is

$$-\Delta = \frac{\partial^2}{\partial z^2} + z^2 \frac{\partial^2}{\partial \theta^2} + \left(\frac{1}{z} - z\right) \frac{\partial}{\partial z}. \quad (2)$$

By construction, Δ is symmetric on $L^2(\mathbb{S}^2 \setminus S, d\mu_g)$, where the Riemannian measure is

$$d\mu_g = \frac{1}{|z|} d\theta dz. \quad (3)$$

It turns out that Δ is essentially self-adjoint with compact resolvent [9]. Due to the high symmetry of the problem, the spectrum can be explicitly computed, cf. [10], and satisfies the following non-classical Weyl's asymptotics:

$$N(\lambda) \sim \frac{1}{4}\lambda \log \lambda, \quad \lambda \rightarrow \infty. \quad (4)$$

Despite the problem taking place on a relatively compact space, the total Riemannian volume is infinite and the curvature explodes to $-\infty$ when approaching the equator. Hence, on-diagonal small-time heat kernel estimates blow up at the singular region. The Laplace-Beltrami operator is not even defined at the singularity, and it is not clear how to deduce the asymptotics of $N(\lambda)$ using classical Tauberian techniques [13].

The class of singular structures that we study in this paper is inspired by the Grushin sphere, and it is determined by the control on the blow-up of intrinsic quantities such as curvature, injectivity radius, cf. Assumption **A**. The corresponding Laplace-Beltrami operators should not be confused with the class of degenerate operators studied in the vast literature in microlocal analysis, cf. for example [50, 8] and references within, or [33, Chapter 12]. In these references, very general operators with degenerate symbol are studied on suitable L^2 spaces, with respect to a measure that remains regular at the degeneration locus. In all these cases the corresponding integral kernels remain well-defined at the degeneration locus, and there is no real singularity. Hence, precise local asymptotics can be recovered by parametrix-based methods. The presence of degeneracies modifies spectral estimates close to the degeneration locus to yield non-standard Weyl asymptotics [33, Thm. 12.5.10]. Our class of operators is not even defined at the singularity, and the full symbol has singular terms, as it is clear from the example of (2).

1.2 Setting and main results

Let (\mathbb{M}, g) be a non-complete Riemannian manifold. Intrinsic quantities such as the curvature, the measure of balls, et cætera, can blow up when approaching the metric boundary of \mathbb{M} , which we thus consider as a singularity. We require the following assumption.

Assumption A. Let δ be the distance from the metric boundary of \mathbb{M} . Then, there exists a neighborhood $U = \{\delta < \varepsilon_0\}$ on which the following hold:

- (a) regularity: δ is smooth;
- (b) convexity: the level sets of δ are convex, i.e., $\text{Hess}(\delta) \leq 0$;
- (c) curvature control: there exists $C > 0$ such that $|\text{Sec}| \leq C\delta^{-2}$;
- (d) injectivity radius control: there exists $C > 0$ such that $\text{inj} \geq C\delta$.

By (a), we identify $U \simeq (0, \varepsilon_0) \times Z$, for a fixed $(n-1)$ -dimensional manifold Z without boundary. The metric on U has the form

$$g = dx^2 + h(x), \quad (5)$$

where $h(x)$ is a smooth one-parameter family of Riemannian metrics on Z . In particular, it holds that $\delta(x, z) = x$ for $(x, z) \in U$. The convexity assumption (b) implies that, for any $V \in TZ$, the map $x \mapsto h(x)(V, V)$ is non-increasing. The remaining assumptions impose additional constraints on $h(x)$.

Remark 1.1. Assumption (d) is implied by the others if the convexity is strict, or if the metric is of warped product type in a neighborhood of the singularity, cf. Proposition 3.2. We do not know whether (d) is independent from the other assumptions in general.

Remark 1.2. Assumption (b) implies that the sectional curvature cannot explode to $+\infty$ in the following sense: for any lower bound K_ε of Sec on $\mathbb{M}_\varepsilon^\infty = \{\varepsilon \leq \delta \leq \infty\}$, one has $\liminf_{\varepsilon \rightarrow 0} K_\varepsilon < +\infty$. However, one can build examples satisfying Assumption **A** with curvature oscillating between $\pm\infty$ as $\delta \rightarrow 0$. (E.g., take $v(\lambda) = 3 \log \lambda + \sin \log \lambda$ in the construction of the proof of Theorem 5.4.)

Let Δ be the Friedrichs extension of the Laplace-Beltrami operator on (\mathbb{M}, g) with domain $C_c^\infty(\mathbb{M})$, that is the unique self-adjoint operator in $L^2(\mathbb{M}, d\mu_g)$ associated with the quadratic form

$$Q(u) = \int_{\mathbb{M}} |\nabla u|^2 d\mu_g, \quad \forall u \in C_c^\infty(\mathbb{M}). \quad (6)$$

To quantify the rate of growth of the volume at the singularity, let $\mathbb{M}_\varepsilon^\infty$ be the set at distance greater than $\varepsilon > 0$ from the metric boundary, and define

$$v(\lambda) := \text{vol} \left(\mathbb{M}_{1/\sqrt{\lambda}}^\infty \right). \quad (7)$$

Our first result, proved in Section 4, is the following.

Theorem 1.1. *Let \mathbb{M} be a n -dimensional Riemannian manifold with compact metric completion and satisfying Assumption **A**. Then, there exist $C_\pm > 0$ and $\Lambda > 0$ such that*

$$C_- \leq \frac{N(\lambda)}{\lambda^{n/2} v(\lambda)} \leq C_+, \quad \forall \lambda \geq \Lambda. \quad (8)$$

It is not clear whether the limit for $\lambda \rightarrow \infty$ exists in our general setting. Our second result, proved in Section 5, is a precise Weyl's law under an additional assumption on the volume growth, ruling out rapid oscillations and growth. Recall that v is slowly varying at infinity if $v(a\lambda) \sim v(\lambda)$ as $\lambda \rightarrow \infty$ for all positive a , see [7]. Some examples of slowly varying functions are $\log \lambda$, the iterates $\log_k \lambda = \log_{k-1} \log \lambda$, rational functions with positive coefficients formed with the $\log_k \lambda$.

Theorem 1.2. *Let \mathbb{M} be an n -dimensional Riemannian manifold with compact metric completion and satisfying Assumption **A**. Then, if v is slowly varying, we have*

$$\lim_{\lambda \rightarrow \infty} \frac{N(\lambda)}{\lambda^{n/2} v(\lambda)} = \frac{\omega_n}{(2\pi)^n}. \quad (9)$$

Remark 1.3. The assumptions of Theorem 1.2 are verified for the Grushin sphere of Section 1.1, and more generally for generic 2-dimensional ARS without tangency points [9]. In these cases, $v(\lambda) = \sigma \log \lambda$ for some $\sigma > 0$ depending on the structure, see Section 7.

We now turn to the inverse problem of building structures with prescribed large eigenvalues asymptotic (see Section 5). The next theorem can be seen as a counterpart at infinity of a celebrated result of Y. Colin de Verdière [19] stating that, for any finite sequence of numbers $0 < \lambda_1 \leq \lambda_2 \leq \dots \leq \lambda_m$, one can find a compact Riemannian manifold such that these numbers are the first m eigenvalues.

Theorem 1.3. *Let N be an n -dimensional compact manifold, $S \subset N$ be a closed submanifold, and $v : \mathbb{R}_+ \rightarrow \mathbb{R}_+$ be a non-decreasing slowly varying function. Then, there exists a Riemannian structure on N , singular at S , such that Weyl's law (9) holds.*

We stress that S can also be a finite set and that, as a consequence of the construction in the proof of Theorem 1.3, the corresponding Laplace-Beltrami operator is essentially self-adjoint, see Remark 5.1.

Via a classical argument, we also prove the concentration of eigenfunctions of the Laplace-Beltrami operator at the metric boundary, in presence of a non-classical Weyl's asymptotics. A precise statement is the following (see Section 6).

Theorem 1.4. *Let \mathbb{M} be an n -dimensional Riemannian manifold such that the Laplace-Beltrami operator Δ has discrete spectrum, and*

$$\lim_{\lambda \rightarrow \infty} \frac{N(\lambda)}{\lambda^{n/2}} = \infty. \quad (10)$$

Let $\{\phi_i\}_{i \in \mathbb{N}}$, be a complete set of normalized eigenfunctions of $-\Delta$, associated with eigenvalues λ_i , arranged in non-decreasing order. Then, there exists a density one subset $S \subseteq \mathbb{N}$ such that for any compact U it holds

$$\lim_{\substack{i \rightarrow \infty \\ i \in S}} \int_U |\phi_i|^2 d\mu_g = 0. \quad (11)$$

Condition (10) implies that \mathbb{M} is not compact. Moreover, Theorem 1.4 applies to all structures satisfying the assumptions of Theorem 1.1 and with infinite volume.

1.3 Quantitative remainder for heat trace asymptotics

In order to highlight a key technical tool of independent interest, we sketch here the proof of Theorem 1.1. It consists in the simultaneous exploitation of Dirichlet-Neumann bracketing (classically used in the Euclidean case) and Tauberian techniques (classically used when all intrinsic geometric quantities are bounded).

The idea is to consider the splitting $\mathbb{M} = \mathbb{M}_0^\varepsilon \cup \mathbb{M}_\varepsilon^\infty$ in a boundary (singular) part and an inner (regular) one. By Dirichlet-Neumann bracketing, $N(\lambda)$ is controlled by the counting functions for the Laplace-Beltrami operator on the two domains, with Neumann (+) or Dirichlet (−) boundary conditions, respectively:

$$N_{[0,\varepsilon]}^-(\lambda) + N_{[\varepsilon,\infty]}^-(\lambda) \leq N(\lambda) \leq N_{[0,\varepsilon]}^+(\lambda) + N_{[\varepsilon,\infty]}^+(\lambda). \quad (12)$$

Thanks to the convexity assumption, \mathbb{M}_0^ε supports a Hardy-type inequality. As a consequence, $N_{[0,\varepsilon(\lambda)]}^\pm(\lambda) = 0$, provided that $\varepsilon = \varepsilon(\lambda) \rightarrow 0$ sufficiently fast (in a quantitative way) as $\lambda \rightarrow \infty$. In this regime, the asymptotics of $N(\lambda)$ is controlled by the Weyl function of the truncation $\mathbb{M}_{\varepsilon(\lambda)}^\infty$. The latter is a Riemannian manifold with boundary and finite volume, which satisfies indeed the classical Weyl's law

$$N_{[\varepsilon(\lambda),\infty]}^\pm(\lambda) \sim \frac{\omega_n}{(2\pi)^n} \text{vol}(\mathbb{M}_{\varepsilon(\lambda)}^\infty) \lambda^{n/2}. \quad (13)$$

The implicit remainder in (13), which depends on the parameter of the truncation $\varepsilon(\lambda)$, must be carefully controlled as $\lambda \rightarrow \infty$. The key is the following heat-trace asymptotic formula with remainder, proved in Section 2. We use d_∂ and $\text{inj}_\partial(M)$ to denote the Riemannian distance and the injectivity radius from ∂M , respectively.

Theorem 1.5. *Let (M, g) be a compact n -dimensional Riemannian manifold with convex boundary ∂M . Let $K, H \geq 0$ such that $|\text{Sec}(M)| \leq K$ and $|\text{Hess}(d_\partial)| \leq H$ for $d_\partial <$*

$\text{inj}_\partial(M)$. Then there exists a constant $c > 0$, depending only on n , such that the following estimate for the Dirichlet and Neumann heat kernels E^\pm holds:

$$\left| \frac{(4\pi t)^{n/2}}{\text{vol}(M)} \int_M E^\pm(t, q, q) d\mu_g(q) - 1 \right| \leq c \left(\frac{t}{t_0} \right)^{1/2}, \quad (14)$$

for all values of $t \in \mathbb{R}_+$ such that

$$\sqrt{t} \leq \sqrt{t_0} = \min \left\{ \text{inj}(M), \frac{\text{inj}_\partial(M)}{2}, \frac{\pi}{\sqrt{K}}, \frac{1}{H} \right\}. \quad (15)$$

As a consequence of Theorem 1.5, and a suitable Karamata-type theorem with remainder, we obtain an asymptotic formula with universal remainder¹ for the eigenvalue counting function of the Laplace-Beltrami operator on a compact Riemannian manifold with convex boundary as $\lambda \rightarrow \infty$ (see Theorem 2.5). The latter implies a Buser's inequality similar to the one proved in [30] with different techniques (see Corollary 2.6).

When applied to $M = \mathbb{M}_\varepsilon^\infty(\lambda)$, this result singles out the quantities whose explosion must be controlled as $\lambda \rightarrow \infty$ and $\varepsilon \rightarrow 0$, concluding the proof of Theorem 1.1.

1.4 Structure of the paper

The first part of the paper, contained in Section 2, is devoted to the non-singular case. Here, we prove heat kernel and trace asymptotics with universal remainder for Riemannian manifolds with boundary. As a consequence we deduce a universal estimate on the remainder of the Riemannian Weyl's law.

In Section 3 we present some preliminary results regarding singular Riemannian manifolds satisfying Assumption **A** which we exploit, in Section 4, to prove Theorem 1.1. Section 5 is dedicated to singular manifolds with slowly varying volumes, and in particular to the proofs of Theorem 1.2 and Theorem 1.3, while in Section 6 we prove Theorem 1.4 on the localization of eigenfunctions. Finally, in Section 7, we apply our results to a class of almost-Riemannian structures, which generalize the Grushin sphere model.

We conclude the paper with two appendices. In the first one we collected some technical geometric estimates, while in the second one we present some functional analytic results for singular Riemannian manifolds satisfying Assumption **A**.

1.5 Other classes of singular structures

There are several types of ‘‘singular structures’’ occurring in the literature. To put our contribution in perspective, we provide here a non-exhaustive overview.

Conical singularities. There is a sharp difference between our class of singularities and conical ones [15]. In the latter case, our techniques do not apply since the boundaries of the truncations $\mathbb{M}_\varepsilon^\infty$ are concave as $\varepsilon \rightarrow 0$. However, the spectrum of the Laplace-Beltrami is still discrete, the total volume is finite, and the classical Weyl's law (1) holds. In this sense, conical singularities are more gentle, and do not change the leading order of the counting function. Indeed, they are detected only at higher order, see [51, 52].

¹By ‘‘universal remainder’’, we mean that it depends on the structure only through a handful of geometrical invariants, and fixed dimensional constants.

Conformally cusp singularities. The spectral properties of conformally cusp type singularities have been studied in [27]. In that reference, the authors derive a nice non-classical Weyl's law for the Laplace-Beltrami operator acting on k -forms, under suitable conditions on the topology of the singularity (which in particular exclude the case $k = 0$). Note that the class of conformally cusp manifolds studied in [27] does not contain our class of singularities: when the singularity is at finite distance (i.e., in the non-complete case) the structure is of metric horn type, cf. [14].

Structures with locally bounded geometry. In [38], the author considers non-complete Riemannian structures (\mathbb{M}, g) equipped with a weighted measure $\sigma^2 d\mu_g$. The Riemannian measure μ_g and the weight σ might be singular at the metric boundary, and no regularity of the latter is assumed. In this setting, the author derives in this setting a Weyl's law similar to the one of Theorem 1.1, and the unique self-adjoint operator in $L^2(\mathbb{M}, \sigma^2 d\mu_g)$, associated with the Friedrichs extension of the quadratic form

$$Q(u) = \int_{\mathbb{M}} |\nabla u|^2 \sigma^2 d\mu_g, \quad u \in C_c^\infty(\mathbb{M}). \quad (16)$$

Despite the similarities, the setting and methods of [38] are rather different with respect to ours. The assumptions in [38] imply that \mathbb{M} is locally *uniformly* bi-Lipschitz equivalent to an Euclidean ball. If the metric completion is compact, this implies that the Riemannian volume of \mathbb{M} is finite. In particular [38] cannot be applied to the Grushin sphere.

ARS with smooth measures. An analogue to Theorem 1.2 for 2-dimensional ARS was announced in [21] as a consequence of a more general local Weyl's law for sub-Laplacians [22, 20]. There, the authors are concerned with the Friedrichs extension associated with the quadratic form

$$Q(u) = \int_N |\nabla u|^2 d\omega, \quad u \in C^\infty(N), \quad (17)$$

where N is a smooth compact manifold carrying a smooth almost-Riemannian structure and the measure ω is positive and smooth on N , including on the singular region $S \subset N$. The reader not familiar with AR geometry can think at the example of the Grushin sphere discussed above, where $N = \mathbb{S}^2$ and the measure ω is the standard measure of the sphere. It is surprising that, for generic 2-ARS, we obtain the same Weyl's law in our setting, where $\omega = \mu_g$ is singular on S and the domain of the form (17) is $C_c^\infty(N \setminus S)$. See also [40] for a partial result covering in particular the Grushin sphere with smooth measure.

Magnetic bottles. It would be interesting to extend our results to the magnetic Laplacian, that is the self-adjoint operator $-\Delta_A$ associated with the quadratic form

$$Q_A(u) = \int_{\mathbb{M}} |du - iuA|^2 d\mu_g, \quad u \in C_c^\infty(\mathbb{M}), \quad (18)$$

where (\mathbb{M}, g) is a Riemannian manifold, A is a one-form representing the magnetic potential, and $|\cdot|$ here is the dual Riemannian norm on the complexified cotangent bundle. When $-\Delta_A$ has compact resolvent and is essentially self-adjoint on $C_c^\infty(\mathbb{M})$, one talks about *magnetic bottles*. The Weyl's law for magnetic bottles on \mathbb{R}^n has been studied in [18], for the Poincaré half-plane in [41], and more generally for geometrically finite hyperbolic surfaces in [42]. In all these cases, the results are obtained by the variational method and by localization on suitable small cubes. To our knowledge, the problem on manifolds with non-constant and possibly exploding curvature has not been yet addressed.

Metric measure spaces. Recently, in [5, 54], the authors studied the convergence of heat kernels for sequences of RCD spaces (infinitesimally Hilbertian metric measure spaces with Ricci curvature bounded from below). This class includes measured Gromov-Hausdorff limits of complete Riemannian structures with Ricci curvature bounded from below and dimension bounded from above. As a consequence, the authors also prove that any RCD space satisfies the classical Weyl’s law (1). Our contribution can be seen as the first step toward the investigation of the Weyl’s law for limits of Riemannian structures (X_n, g_n, μ_{g_n}) , where the Ricci curvature is unbounded.

Acknowledgments

This work was supported by the Grants ANR-15-CE40-0018 and ANR-18-CE40-0012 of the ANR, and by a public grant as part of the Investissement d’avenir project, reference ANR-11-LABX-0056-LMH, LabEx LMH, in a joint call with the “FMJH Program Gaspard Monge in optimization and operation research”. This work has been supported by the ANR project ANR-15-IDEX-02 and by a public grant overseen by the French National Research Agency (ANR) as part of the Investissement d’avenir program, through the iCODE project funded by the IDEX Paris-Saclay, ANR-11-IDEX-0003-02.

We wish to thank S. Gallot, R. Neel, and E. Trelat for stimulating discussions, and also Y. Colin de Verdière for his helpful suggestions that, in particular, led to Section 6. We also warmly thank L. de Haan for pointing out a technical result due to A. A. Balkema about de Haan functions contained in [24, Appendix B], key to the proof of Theorem 1.2. We finally thank V. Ivrii for his comments on a preliminary version of this work.

2 Heat kernel estimates with remainder

In this section, we prove on-diagonal estimates for the heat kernel and its trace on a compact Riemannian manifold with boundary, with explicit remainder control. We recall first some basic definitions valid in the more general non-complete setting.

2.1 Notation and basic definitions

For a Riemannian manifold (M, g) , possibly non-complete and with boundary, the injectivity radius from $p \in M$ is the supremum of lengths $\ell > 0$ such that every geodesic of length smaller than ℓ emanating from p is length-minimizing. The injectivity radius of M , denoted by $\text{inj}(M)$, is then the infimum of the injectivity radius over M . This definition extends the classical one. Observe that the exponential map $\exp_p : T_p M \rightarrow M$ is a diffeomorphism when restricted to any ball of radius smaller than the injectivity radius from p and contained in the domain of the exponential map (geodesics cease to be defined when they hit the boundary or the metric boundary of the manifold).

We denote the Riemannian distance from ∂M by $d_\partial : M \rightarrow [0, +\infty)$, that is

$$d_\partial(p) = \inf_{q \in \partial M} d(p, q). \tag{19}$$

A length-parametrized geodesic $\gamma : [0, t] \rightarrow M$, $\gamma(0) \in \partial M$ is length-minimizing from the boundary if for all $0 \leq s < t$ it holds $d_\partial(\gamma(s)) = s$. It follows that $\dot{\gamma}(0) \perp T_{\gamma(0)}\partial M$ and that $\gamma(0)$ is the only point of ∂M realizing $d_\partial(\gamma(s))$. The injectivity radius from the boundary, denoted by $\text{inj}_\partial(M)$, is then defined as $\text{inj}(M)$ considering only length-minimizing geodesics from the boundary.

For a smooth function $f : M \rightarrow \mathbb{R}$, we let

$$\text{Hess}(f)(X, Y) = g(\nabla_X \nabla f, Y), \quad X, Y \in \Gamma(M), \quad (20)$$

where ∇ denotes the covariant derivative. The notation $\text{Hess}(f) \geq c$ (resp. $\leq c$) for some constant $c \in \mathbb{R}$ is to be understood in the sense of quadratic forms and w.r.t. the metric g . The boundary ∂M is convex (resp. strictly convex) if its second fundamental form $\text{Hess}(d_\partial)|_{T\partial M}$ is non-positive (resp. negative). Moreover, it is mean convex if $\text{Tr Hess}(d_\partial)|_{T\partial M} \leq 0$.

2.2 On-diagonal heat kernel estimates

The Dirichlet and Neumann heat kernels E^+ and E^- are the minimal fundamental solutions of the heat equation associated with the Laplace-Beltrami operator Δ with Dirichlet or Neumann boundary conditions. We denote the corresponding self-adjoint operators by Δ^+ and Δ^- , respectively. The first result of the section is the following. Henceforth, we use the convention that $1/0 = +\infty$.

Theorem 2.1. *Let (M, g) be a compact n -dimensional Riemannian manifold with convex boundary ∂M . Let $K \geq 0$ be such that $|\text{Sec}(M)| \leq K$. Moreover, let*

$$\rho(q) = \min \left\{ \frac{d_\partial(q)}{2}, \text{inj}(M) \right\}, \quad \forall q \in M. \quad (21)$$

Then there exist constants $c_1, c_2, c_3 > 0$ depending only on n , such that

$$\left| (4\pi t)^{n/2} E^\pm(t, q, q) - 1 \right| \leq c_1 K t + c_2 e^{-c_3 \frac{\rho(q)^2}{4t}}, \quad (22)$$

for any $q \in M$ and $t \in \mathbb{R}_+$ such that

$$\sqrt{t} \leq \min \left\{ \rho(q), \frac{\pi}{\sqrt{K}} \right\}. \quad (23)$$

Proof. Consider the double $\bar{M} = M \cup_{\partial M} M$ of M , which is a compact smooth manifold without boundary, endowed with the Lipschitz metric \bar{g} inherited from g . Let \bar{d} and $\bar{\mu}$ denote the corresponding metric and measure on \bar{M} . Clearly, \bar{d} and $\bar{\mu}$ coincide with d and μ , when restricted to either isometric copy $M \subset \bar{M}$. Following [39], although the coefficients of the Laplace-Beltrami operator are discontinuous, there is a well-defined heat kernel \bar{E} on (\bar{M}, \bar{g}) , which satisfies

$$E^\pm(t, p, q) = \bar{E}(t, p, q) \mp \bar{E}(t, p, q^*), \quad \forall p, q \in M, \quad (24)$$

where $q^* \in \bar{M}$ denotes the reflection of q w.r.t. the boundary $\partial M \in \bar{M}$. We decompose the argument in several steps.

Step 1. Gromov-Hausdorff approximation. For $\tau > 0$, there exists a sequence \bar{g}_τ of smooth Riemannian metrics on \bar{M} such that

- $(\bar{M}, \bar{d}_\tau, \bar{\mu}_\tau) \rightarrow (\bar{M}, \bar{d}, \bar{\mu})$ in the measured Gromov-Hausdorff sense, as $\tau \rightarrow 0$;
- $\text{Ric}(\bar{g}_\tau) \geq -K(n-1)$, for all $\tau > 0$;
- for any compact set K such that $K \cap \partial M = \emptyset$ and for sufficiently small τ , we have $\bar{g}_\tau|_K = \bar{g}|_K$;

- the distance to ∂M in \bar{M} w.r.t. \bar{g}_τ coincides with d_∂ , seen as a function on \bar{M} .

The construction of $(\bar{g}_\tau)_{\tau>0}$ is sketched in [44, Sec. 4] for positive Ricci curvature and strictly convex boundary, and can be extended to the case of convex boundary, see [53, Thm. 1.8] and references therein. The measured Gromov-Hausdorff convergence in the sense of Fukaya [26] follows from the fact that $\bar{g}_\tau \rightarrow \bar{g}$ uniformly in coordinates.

As a consequence of the measured Gromov-Hausdorff convergence and the Ricci bound, we have that the corresponding heat kernels \bar{E}^τ satisfy

$$\lim_{\tau \downarrow 0} \bar{E}^\tau(t, p, q) = \bar{E}(t, p, q), \quad \forall (t, p, q) \in \mathbb{R}_+ \times \bar{M} \times \bar{M}, \quad (25)$$

uniformly on $\bar{M} \times \bar{M}$, for any fixed t . See [25, Thm. 2.6].

We will now prove lower and upper bounds for \bar{E}^τ that are uniform w.r.t. τ . Passing to the limit and using (24) will then yield the statement.

Step 2. Lower bound. The lower bound on \bar{E}^τ is a consequence of classical comparison theorems for the heat kernel on complete manifolds without boundary and Ricci lower bound, see e.g. [13, Thm. 7, p. 196]. Namely, if we let $E_{-K}(t, r)$ be the heat kernel for the simply connected space form of constant curvature $-K$ we obtain $E_{-K}(t, \bar{d}_\tau(p, q)) \leq \bar{E}^\tau(t, p, q)$ for all $(t, p, q) \in \mathbb{R}_+ \times \bar{M} \times \bar{M}$ and $\tau > 0$. In particular, as $\tau \rightarrow 0$, we have

$$E_{-K}(t, \bar{d}(p, q)) \leq \bar{E}(t, p, q), \quad \forall (t, p, q) \in \mathbb{R}_+ \times \bar{M} \times \bar{M}. \quad (26)$$

Step 3. Upper bound. In this case, classical comparison theorems are only local. Nevertheless, we claim that there exists positive constants $c_1, c_2 > 0$, such that for any $o \in M$ and $\sqrt{t} < \min\{\rho(o), \pi/\sqrt{K}\}$, where $\rho(o)$ is defined in (21), it holds

$$\bar{E}(t, o, o) \leq E_K(t, 0) + \frac{c_1}{t^{n/2}} e^{-c_2 \frac{\rho^2(o)}{4t}} \quad \text{and} \quad \bar{E}(t, o, o^*) \leq \frac{c_1}{t^{n/2}} e^{-c_2 \frac{\rho^2(o)}{4t}}. \quad (27)$$

Here, we denoted by $\bar{B}_o(r)$ (resp. $\bar{B}_o^\tau(r)$) the open ball with center o and radius $r > 0$ with respect to the metric \bar{d} (resp. \bar{d}_τ). When the ball is completely contained in one of the two copies of M in \bar{M} , we drop the bar since no confusion arises.

Fix $o \in M$, and let $\rho = \rho(o)$. Let $\Omega = B_o(\rho)$. By definition of ρ , the closure of $\Omega = \bar{B}_o^\tau(\rho)$ is contained in one of the two copies of $M \subset \bar{M}$, and does not intersect ∂M . Hence, assuming τ sufficiently small, we have $\bar{g}_\tau|_\Omega = g|_\Omega$, and

$$\Omega = \bar{B}_o^\tau(\rho) = \bar{B}_o(\rho) = B_o(\rho). \quad (28)$$

Denote by $\bar{E}_\Omega^\tau(t, p, q)$ the heat kernel w.r.t. \bar{g}_τ on Ω with Dirichlet boundary condition, which we set to zero if p or $q \notin \Omega$. The Markov property of the heat kernel implies

$$\bar{E}^\tau(t, o, q) \leq \bar{E}_\Omega^\tau(t, o, q) + \sup_{\substack{0 < s \leq t \\ p \in \partial\Omega}} \bar{E}^\tau(s, p, q). \quad (29)$$

This follows, e.g., by applying [29, Lemma 3.1] and upper-bounding the hitting probability appearing there by 1. We now estimate the two terms appearing on the r.h.s. of (29), which we will refer to as the local and the global term, respectively, for the cases $q = o$ and $q = o^*$.

Let us start by considering the local term. Since $\Omega \subset M$, it follows that $o^* \notin \Omega$, and hence, for $q = o^*$, we have

$$\bar{E}_\Omega^\tau(t, o, o^*) = 0. \quad (30)$$

Let now $q = o$. Since $\rho \leq \text{inj}(M)$ and $\Omega = \bar{B}_o^\tau(\rho)$ lies in the region of M where the metric is unperturbed, one has that Ω lies within the injectivity radius from o . Therefore, we can apply [13, Thm. 6, p. 194] and the domain monotonicity property of the Dirichlet heat kernel to obtain

$$\bar{E}_\Omega^\tau(t, o, o) \leq E_K(t, 0). \quad (31)$$

The global term in (29) is more delicate. Observe that the Li-Yau inequality (see Lemma A.4) requires only a lower bound on the Ricci curvature, and hence can be applied to the compact Riemannian manifold with no boundary (\bar{M}, \bar{g}_τ) , for which $\text{Ric}(\bar{g}_\tau) \geq -(n-1)K$, for all $\tau > 0$. As a consequence, there exist constants $C_1, C_2, C_3 > 0$, depending only on the dimension n of \bar{M} , such that

$$\bar{E}^\tau(s, p, q) \leq \frac{C_1}{\sqrt{\text{vol}^\tau(\bar{B}_p^\tau(\sqrt{s}))\text{vol}^\tau(\bar{B}_q^\tau(\sqrt{s}))}} e^{C_2 K s - C_3 \frac{\bar{d}_\tau^2(p, q)}{4s}}, \quad \forall (s, p, q) \in \mathbb{R}_+ \times \bar{M} \times \bar{M}. \quad (32)$$

Recall that $p \in \partial \bar{B}_o^\tau(\rho)$, and $\rho = \rho(o) \leq d_\partial(o)/2$. Therefore $\bar{d}_\tau(p, o) = \rho$, and

$$\bar{d}_\tau(p, o^*) \geq \bar{d}_\tau(o, o^*) - \bar{d}_\tau(p, o) = 2d_\partial(o) - \rho \geq 3\rho \geq \rho. \quad (33)$$

Hence, (32), for both cases $q \in \{o, o^*\}$, yields

$$\bar{E}^\tau(s, p, q) \leq \frac{C_1}{\sqrt{\text{vol}^\tau(\bar{B}_p^\tau(\sqrt{s}))\text{vol}^\tau(\bar{B}_q^\tau(\sqrt{s}))}} e^{C_2 K s - C_3 \frac{\rho^2(o)}{4s}}, \quad q \in \{o, o^*\}. \quad (34)$$

Recall now that in (29) $s \leq t$. Furthermore $\sqrt{t} \leq \rho = \min\{\frac{d_\partial(o)}{2}, \text{inj}(M)\}$. It follows that $\bar{B}_q^\tau(\sqrt{s})$, for $q \in \{o, o^*\}$, does not intersect ∂M , and hence, we can choose τ sufficiently small so that these sets lie in the region of \bar{M} where the metric is unperturbed, yielding

$$\text{vol}^\tau(\bar{B}_q(\sqrt{s})) = \text{vol}(B_q(\sqrt{s})), \quad \forall s \leq t, \quad q \in \{o, o^*\}. \quad (35)$$

Furthermore, since $\sqrt{t} \leq \text{inj}(M)$, and thanks to the upper bound on the sectional curvature of (M, g) , we can bound from below the r.h.s. of (35) with the volume of the analogue ball in the simply connected space form of curvature K , yielding

$$\text{vol}^\tau(\bar{B}_q(\sqrt{s})) \geq \text{vol}(B_K(\sqrt{s})), \quad \forall s \leq t, \quad q \in \{o, o^*\}. \quad (36)$$

Finally, since $\sqrt{t} \leq \frac{\pi}{\sqrt{K}}$, we deduce (see Lemma A.2) the existence of a constant $C > 0$ depending only on n such that, for τ sufficiently small, it holds

$$\text{vol}^\tau(\bar{B}_q^\tau(\sqrt{s})) \geq C s^{n/2}, \quad \forall s \leq t, \quad q \in \{o, o^*\}. \quad (37)$$

The same argument shows that (37) holds also when replacing q with $p \in \partial \Omega$ for τ small. By plugging (37) in (34), using again that $Ks \leq \pi^2$, and renaming the constants, we deduce that

$$\bar{E}^\tau(s, p, q) \leq \frac{c_1}{s^{n/2}} e^{-c_2 \frac{\rho^2(o)}{4s}}, \quad \forall s \leq t, \quad q \in \{o, o^*\}. \quad (38)$$

An elementary argument show that, up to enlarging the constant c_1 (which still depends only on n), one has

$$\sup_{\substack{0 < s \leq t \\ p \in \partial \Omega}} \bar{E}^\tau(s, p, q) \leq \frac{c_1}{t^{n/2}} e^{-c_2 \frac{\rho^2(o)}{4t}}, \quad q \in \{o, o^*\}, \quad (39)$$

which is the the final estimate for the global part of (29).

By (30) (resp. (31)) and (39), passing to the limit as $\tau \rightarrow 0$ in (29), completes the proof of the upper bounds (27).

Step 4. Conclusion. By (24), the lower bound (26) and the upper bound (27) for the heat kernel on the double \bar{M} yield the following on-diagonal estimates for the Dirichlet and Neumann heat kernels of the original manifold with boundary:

$$E_{-K}(t, 0) - \frac{C_1}{t^{n/2}} e^{-C_3 \frac{\rho^2(o)}{4t}} \leq E^\pm(t, o, o) \leq E_K(t, 0) + \frac{2C_1}{t^{n/2}} e^{-C_3 \frac{\rho^2(o)}{4t}}, \quad (40)$$

valid for all $0 < \sqrt{t} \leq \min\{\rho(o), \frac{\pi}{\sqrt{K}}\}$. We conclude by using the uniform estimates of the model kernels $E_{\pm K}(t, 0)$ given in Lemma A.1 (which we apply with $T = \pi^2$). \square

2.3 Heat trace bound

In this section we apply Theorem 2.1 to estimate the heat trace on M .

Theorem 2.2. *Let (M, g) be a smooth compact n -dimensional Riemannian manifold with convex boundary ∂M . Let $K, H \geq 0$ such that $|\text{Sec}(M)| \leq K$ and $|\text{Hess}(d_\partial)| \leq H$ for $d_\partial < \text{inj}_\partial(M)$. Then there exists a constant $c > 0$, depending only on n , such that the following estimate for the Dirichlet and Neumann heat kernels holds:*

$$\left| \frac{(4\pi t)^{n/2}}{\text{vol}(M)} \int_M E^\pm(t, q, q) d\mu_g(q) - 1 \right| \leq c \left(\frac{t}{t_0} \right)^{1/2}, \quad (41)$$

for all values of $t \in \mathbb{R}_+$ such that

$$\sqrt{t} \leq \sqrt{t_0} = \min \left\{ \text{inj}(M), \frac{\text{inj}_\partial(M)}{2}, \frac{\pi}{\sqrt{K}}, \frac{1}{H} \right\}. \quad (42)$$

Proof. Fix t as in our assumptions. Let $\mathfrak{i} = \min\{\text{inj}(M), \frac{\text{inj}_\partial(M)}{2}\}$. We split M into 3 disjoint components (see Figure 1):

$$\Omega_1 = \left\{ \frac{d_\partial}{2} < \sqrt{t} \right\}, \quad \Omega_2 = \left\{ \sqrt{t} \leq \frac{d_\partial}{2} < \mathfrak{i} \right\}, \quad \Omega_3 = \left\{ \mathfrak{i} \leq \frac{d_\partial}{2} \right\}. \quad (43)$$

We estimate the heat trace on these three sets separately.

Estimate on Ω_1 . By definition, and thanks to our assumption on t , we have

$$\frac{d_\partial}{2} < \sqrt{t} \leq \min \left\{ \text{inj}(M), \frac{\text{inj}_\partial(M)}{2}, \frac{\pi}{\sqrt{K}}, \frac{1}{H} \right\}. \quad (44)$$

It follows that $\rho(q) = d_\partial(q)/2$ for any $q \in \Omega_1$, where ρ is defined in (21). Furthermore, $d_\partial(q) < \text{inj}_\partial(M)$, that is, Ω_1 is contained inside the injectivity radius from the boundary. Observe that, by construction, $\sqrt{t} > \rho(q)$, and one cannot apply the bound of Theorem 2.1. However, the assumption on t allows one to apply the Li-Yau type estimate (206) of Lemma A.4. This yields,

$$\int_{\Omega_1} |(4\pi t)^{n/2} E^\pm(t, q, q) - 1| d\mu_g(q) \leq C_4 \text{vol}(\Omega_1). \quad (45)$$

In addition, we have

$$\text{vol}(\Omega_1) = \int_0^{2\sqrt{t}} \text{vol}(Z_x) dx, \quad (46)$$

where $\text{vol}(Z_x)$ denotes the Riemannian volume of the level set $Z_x = \{d_\partial = x\}$ (a smooth $(n-1)$ -dimensional hypersurface for $x > 0$, with $Z_0 = \partial M$). It holds

$$\frac{d}{dx} \text{vol}(Z_x) = \int_{Z_x} \text{Tr Hess}(d_\partial) d\sigma_x \leq (n-1)H \text{vol}(Z_x), \quad \forall x < \text{inj}_\partial(M), \quad (47)$$

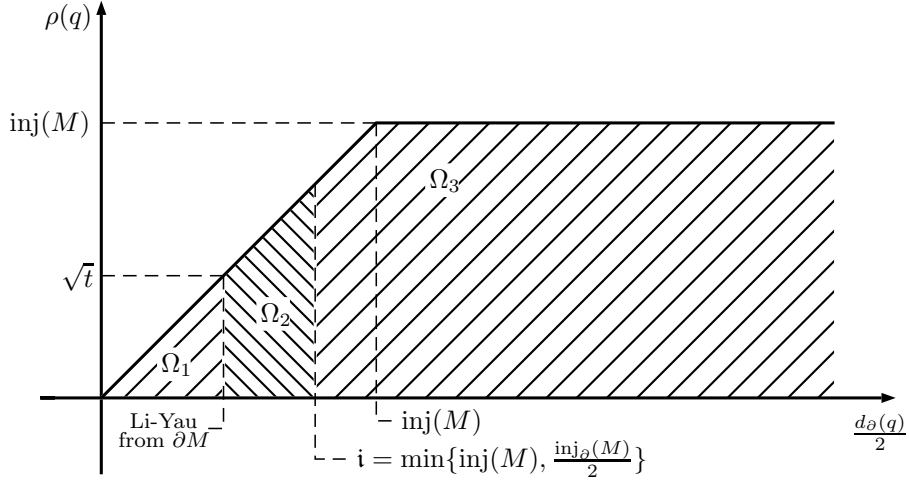

Figure 1: The regions $\Omega_1, \Omega_2, \Omega_3$. The condition $\sqrt{t} \leq \text{inj}(M)$ ensures the existence of Ω_2, Ω_3 where we can apply Theorem 2.1. The condition $\sqrt{t} \leq \min\left\{\text{inj}(M), \frac{\pi}{\sqrt{K}}, \frac{\text{inj}_\partial(M)}{2}, \frac{1}{H}\right\}$ allows one to apply the Li-Yau estimate on Ω_1 .

which implies

$$\text{vol}(Z_x) \leq \text{vol}(\partial M) e^{(n-1)Hx}, \quad \forall x < \text{inj}_\partial(M). \quad (48)$$

Recall now that $t/t_0 \leq 1$, and hence $H\sqrt{t} \leq 1$. Thus, plugging (48) into (46) we conclude the estimate on Ω_1 , which yields together with (45),

$$\int_{\Omega_1} |(4\pi t)^{n/2} E^\pm(t, q, q) - 1| d\mu_g(q) \leq c \text{vol}(\partial M) \sqrt{t}. \quad (49)$$

for some constant $c > 0$ depending only on n .

Estimate on Ω_2 . By construction, Ω_2 still lies in the region within the injectivity radius from ∂M . Furthermore, it still holds $\rho(q) = d_\partial(q)/2$ for $q \in \Omega_2$. Here, however, $\sqrt{t} \leq \min\{\rho(q), \frac{\pi}{\sqrt{K}}\}$, and hence we can apply the result of Theorem 2.1. In particular, denoting with c a generic positive constant depending only on the dimension, whose value can possibly increase at each step, we have

$$\int_{\Omega_2} |(4\pi t)^{n/2} E^\pm(t, q, q) - 1| d\mu_g(q) \leq \int_{\Omega_2} \left(cKt + ce^{-\frac{\rho^2(q)}{ct}} \right) d\mu_g(q) \quad (50)$$

$$= cK \text{vol}(\Omega_2)t + c \int_{\Omega_2} e^{-\frac{d_\partial(q)^2}{ct}} d\mu_g(q) \quad (51)$$

$$= cK \text{vol}(\Omega_2)t + c \int_{2\sqrt{t}}^i e^{-\frac{x^2}{ct}} \text{vol}(Z_x) dx \quad (52)$$

$$\leq cK \text{vol}(\Omega_2)t + c \text{vol}(\partial M) \int_0^\infty e^{-\frac{x^2}{ct} + (n-1)Hx} dx \quad (53)$$

$$\leq cK \text{vol}(\Omega_2)t + c \text{vol}(\partial M) \sqrt{t}. \quad (54)$$

Here, we used the fact that Ω_2 lies within the injectivity radius from ∂M , and hence the estimate (48) holds. Furthermore, we evaluate explicitly the Gaussian integral in the last inequality, and use the fact that $H\sqrt{t} \leq 1$.

Estimate on Ω_3 . For $q \in \Omega_3$, it does not necessarily hold $\rho(q) = d_\partial(q)/2$, neither q is forcibly within the injectivity radius from ∂M . However, it holds $\rho(q) \geq i$. Since we

have $\sqrt{t} \leq i$, this implies that $\sqrt{t} \leq \rho(q)$, and we can apply Theorem 2.1 again. Hence, we obtain

$$\int_{\Omega_3} \left| (4\pi t)^{n/2} E^\pm(t, q, q) - 1 \right| d\mu_g(q) \leq \int_{\Omega_3} \left(cKt + ce^{-\frac{\rho^2(q)}{ct}} \right) d\mu_g(q) \quad (55)$$

$$\leq \left(cKt + ce^{-\frac{i^2}{ct}} \right) \text{vol}(\Omega_3) \quad (56)$$

$$\leq c \left(Kt + \frac{t}{i^2} \right) \text{vol}(\Omega_3). \quad (57)$$

Here, in the last step, we used the inequality $e^{-1/x} \leq x/e$ for $x > 0$.

Since $\text{vol}(\Omega_i)/\text{vol}(M) \leq 1$, splitting the l.h.s. of (41) in the subsets $\Omega_1, \Omega_2, \Omega_3$, using (49), (54), (57), and increasing the constants, yields

$$\left| \frac{(4\pi t)^{n/2}}{\text{vol}(M)} \int_M E^\pm(t, q, q) d\mu_g(q) - 1 \right| \leq c \left(\frac{\text{vol}(\partial M)}{\text{vol}(M)} \sqrt{t} + Kt + \frac{t}{i^2} \right) \quad (58)$$

$$\leq c \left(\frac{\text{vol}(\partial M)}{\text{vol}(M)} \sqrt{t} + \frac{t}{t_0} \right), \quad (59)$$

where we used the definition of t_0 . It remains to estimate the ratio $\text{vol}(\partial M)/\text{vol}(M)$ in (59). Proceeding as in (48), but using this time the lower bound on the Hessian, we obtain the corresponding lower bound

$$\text{vol}(Z_x) \geq \text{vol}(\partial M) e^{-H(n-1)x}, \quad \forall x < \text{inj}_\partial(M). \quad (60)$$

Therefore, since $t_0 \leq i^2$ and $H\sqrt{t_0} \leq 1$, we have

$$\frac{\text{vol}(M)}{\text{vol}(\partial M)} \geq \int_0^{\sqrt{t_0}/(n-1)} \frac{\text{vol}(Z_x)}{\text{vol}(\partial M)} dx \geq \frac{1 - e^{-H\sqrt{t_0}}}{H(n-1)} \geq \frac{\sqrt{t_0}(1 - e^{-1})}{n-1}. \quad (61)$$

By plugging this estimate in (59) and since $t/t_0 \leq 1$, one gets the result. \square

The next corollary is a version of Theorem 2.2, global w.r.t. $t \in \mathbb{R}_+$.

Corollary 2.3. *In the setting of Theorem 2.2, there exists a constant $c > 0$, depending only on the dimension n , such that*

$$\left| \frac{(4\pi t)^{n/2}}{\text{vol}(M)} \int_M E^\pm(t, q, q) d\mu_g(q) - 1 \right| \leq c \begin{cases} (t/t_0)^{1/2} & t \leq t_0, \\ (t/t_0)^{n/2} & t \geq t_0, \end{cases} \quad (62)$$

where $\sqrt{t_0} = \min \left\{ \text{inj}(M), \frac{\text{inj}_\partial(M)}{2}, \frac{\pi}{\sqrt{K}}, \frac{1}{H} \right\}$ is as in (42).

Proof. The case $t \leq t_0$ is the content of Theorem 2.2. Let then $t \geq t_0$, and set $W(t) = \frac{(4\pi)^{n/2}}{\text{vol}(M)} \int_M E^\pm(t, q, q) d\mu_g(q)$. Since $W(t)$ is decreasing and positive, we have

$$\left| W(t) - t^{-n/2} \right| \leq W(t_0) + t_0^{-n/2} \quad (63)$$

$$\leq \left| W(t_0) - t_0^{-n/2} \right| + 2t_0^{-n/2} \quad (64)$$

$$\leq t_0^{-n/2} |t_0^{n/2} W(t_0) - 1| + 2t_0^{-n/2} \quad (65)$$

$$\leq t_0^{-n/2} (c + 2), \quad (66)$$

where we used Theorem 2.2 at $t = t_0$. Up to modifying c , the above inequality implies the statement of the corollary for $t \geq t_0$. \square

2.4 Weyl's law with remainder

When M is compact, the spectrum of $-\Delta_\Omega^\pm$ is a discrete subset of the positive real axis, i.e., $\sigma(-\Delta^\pm) \subset [0, +\infty)$, accumulating at infinity. The eigenvalue counting function is

$$N^\pm(\lambda) := \#(\sigma(-\Delta^\pm) \cap [0, \lambda]). \quad (67)$$

It is well known that heat trace asymptotics imply asymptotics for $N(\lambda)$, by means of Tauberian theorems in the form of Karamata [34]. We need here a Karamata type result with remainder, due to Freud. See [31, Thm. B] or [35, Thm. 3.1] and references within. Since for our purposes we need to know the explicit dependence of the constants with respect to all parameters and functions at play, the statement below is slightly more precise than the one in [31]. However, the proof is unchanged and we omit it.

Theorem 2.4 (Freud's Tauberian Theorem [31]). *Let $\mu : [0, \infty) \rightarrow \mathbb{R}$ be a positive and non-decreasing function. Denote by the same symbol the associated Stieltjes measure. Let $\alpha > -1$, and let $\chi : [0, +\infty) \rightarrow \mathbb{R}$ be a function such that*

$$\chi(\lambda) > 0, \quad \chi(\lambda) \nearrow \infty, \quad \lambda^{-\alpha-1}\chi(\lambda) \searrow, \quad \forall \lambda > 0. \quad (68)$$

Let $\hat{\mu}(t) = \int_0^\infty e^{-t\lambda} d\mu(\lambda)$ denote the Laplace transform of μ . Suppose that there exists $c > 0$ such that

$$|t^\alpha \hat{\mu}(t) - 1| \leq \frac{c}{\chi(1/t)}, \quad \forall t > 0. \quad (69)$$

Then there exists another constant $C = C(c, \alpha) > 0$ such that

$$\left| \frac{\Gamma(\alpha+1)\mu(\lambda)}{\lambda^\alpha} - 1 \right| \leq \frac{C}{\log(\chi(\lambda)+1)}, \quad \forall \lambda > 0. \quad (70)$$

Remark 2.1. Theorem 2.4 in particular recovers the classical statement of Karamata (cf. [7]): if $\hat{\mu}(t) \sim t^{-\alpha}$ as $t \rightarrow 0$, then $\mu(\lambda) \sim \lambda^\alpha/\Gamma(\alpha+1)$ as $\lambda \rightarrow \infty$.

We use Corollary 2.3 to derive the Weyl's law with remainder for M . In order to do that, we define the function $\chi : \mathbb{R}_+ \rightarrow \mathbb{R}_+$ by

$$\chi(\lambda) := \begin{cases} (\lambda/\lambda_0)^{1/2} & \lambda \geq \lambda_0, \\ (\lambda/\lambda_0)^{n/2} & \lambda \leq \lambda_0. \end{cases} \quad (71)$$

Here $\lambda_0 = 1/t_0$ which, using (42), is equal to

$$\sqrt{\lambda_0} = \frac{1}{\min \left\{ \text{inj}(M), \frac{\text{inj}_\partial(M)}{2}, \frac{\pi}{\sqrt{K}}, \frac{1}{H} \right\}}. \quad (72)$$

Theorem 2.5. *Let (M, g) be a compact n -dimensional Riemannian manifold with convex boundary ∂M . Let $K, H \geq 0$ such that $|\text{Sec}(M)| \leq K$ and $|\text{Hess}(d_\partial)| \leq H$ for $d_\partial < \text{inj}_\partial(M)$. Then, there exists a constant $C > 0$, depending only on n , such that the following estimate holds for the eigenvalue counting function for the Dirichlet or Neumann eigenvalues:*

$$\left| \frac{N(\lambda)}{\frac{\omega_n}{(2\pi)^n} \text{vol}(M) \lambda^{n/2}} - 1 \right| \leq \frac{C}{\log(\chi(\lambda)+1)}, \quad \forall \lambda > 0. \quad (73)$$

Proof. The proof is an application of Theorem 2.4. Let

$$\mu(\lambda) = \frac{(4\pi)^{n/2}}{\text{vol}(M)} N(\lambda). \quad (74)$$

The Laplace transform of the corresponding measure satisfies

$$\hat{\mu}(t) = \frac{(4\pi)^{n/2}}{\text{vol}(M)} \int_0^\infty e^{-t\lambda} dN(\lambda) = \frac{(4\pi)^{n/2}}{\text{vol}(M)} \sum_{i=1}^\infty e^{-t\lambda_i} = \frac{(4\pi)^{n/2}}{\text{vol}(M)} \int_M E^\pm(t, q, q) d\mu_g. \quad (75)$$

By Corollary 2.3, $\hat{\mu}$ satisfies the assumptions in Theorem 2.4 with $\alpha = n/2$, and χ defined in (71). We conclude by recalling that $\Gamma(\frac{n}{2} + 1) = \frac{\pi^{n/2}}{\omega_n}$. \square

The upper bound in Theorem 2.5 can be seen as a version of Buser's inequality whose leading order constant is sharp as $\lambda \rightarrow \infty$. The price to pay for sharpness are stronger curvature assumptions, since the classical Buser's inequality for closed manifolds only requires a Ricci lower bound [11]. In the following, we formulate the upper bound of Theorem 2.5 in a weaker form, more similar to Buser's inequality.

Corollary 2.6. *In the setting of Theorem 2.2, there exists a constant $C > 0$ depending only on n , such that the following estimate holds for the Weyl's counting function for the Dirichlet or Neumann eigenvalues:*

$$N(\lambda) \leq C \text{vol}(M) \left(\lambda^{n/2} + \text{inj}(M)^{-n} + \text{inj}_\partial(M)^{-n} + K^{n/2} + H^n \right), \quad \forall \lambda > 0. \quad (76)$$

See also [30, Sec. 1.2] for more details on Buser's and related inequalities.

3 Geometric structure at the singularity

In this section we collect some preliminary results on non-complete Riemannian manifolds \mathbb{M} satisfying Assumption **A**. The distance from the metric boundary is denoted by δ . It is a Lipschitz function, and it satisfies the eikonal equation $|\nabla\delta| \equiv 1$. For any $0 \leq a < b \leq +\infty$, we let $\mathbb{M}_a^b = \{a \leq \delta \leq b\} \cap \mathbb{M}$. The following lemma collects some basic properties of \mathbb{M} .

Lemma 3.1. *Let \mathbb{M} be a Riemannian manifold with compact metric completion and satisfying Assumption **A**. Then there exists $C > 0$ such that, for all $0 < \varepsilon < \varepsilon_0/2$, the compact manifold with convex boundary $\mathbb{M}_\varepsilon^\infty$ satisfies the following bounds*

$$\text{inj}_\partial(\mathbb{M}_\varepsilon^\infty) \geq \frac{\varepsilon_0}{C}, \quad \text{inj}(\mathbb{M}_\varepsilon^\infty) \geq \frac{\varepsilon}{C}, \quad |\text{Sec}(\mathbb{M}_\varepsilon^\infty)| \leq \frac{C}{\varepsilon^2}, \quad |\text{Hess}(d_\partial)| \leq \frac{C}{\varepsilon}. \quad (77)$$

Proof. We identify $U = \{\delta < \varepsilon_0\}$ with $(0, \varepsilon_0) \times Z$, with metric given by (5). Furthermore $\delta(x, z) = x$ for $(x, z) \in U$. For all $0 < \varepsilon < \varepsilon_0$, the truncation $\mathbb{M}_\varepsilon^\infty$ admits an inward tubular neighborhood $\mathbb{M}_\varepsilon^{\varepsilon_0}$ of its boundary. There, the distance from $\partial\mathbb{M}_\varepsilon^\infty = \{\varepsilon\} \times Z \simeq Z$, satisfies

$$d_\partial(x, z) = \delta(x, z) - \varepsilon = x - \varepsilon. \quad (78)$$

This, in particular, implies the bound on $\text{inj}_\partial(\mathbb{M}_\varepsilon^\infty)$ if $0 < \varepsilon < \varepsilon_0/2$. The bounds on $\text{inj}(\mathbb{M}_\varepsilon^\infty)$ and on $\text{Sec}(\mathbb{M}_\varepsilon^\infty)$ follow from the corresponding assumptions in Assumption **A** and the linear relation between d_∂ and δ . Finally, the bound on the Hessian follows from the sectional curvature bounds and the fact that $\text{Hess}(\delta)$ satisfies a matrix Riccati equation (see [46, Prop. 7, (2)]). \square

Proposition 3.2. *Let \mathbb{M} be a Riemannian manifold with compact metric completion and satisfying Assumption A. If the convexity condition (b) is assumed to be strict, or the metric (5) is of warped product type on a neighborhood of the singularity, then the injectivity radius condition (d) is automatically verified.*

Proof. Let $p, q \in \mathbb{M}$. Let $\gamma : [0, 1] \rightarrow \mathbb{M}$ be a piecewise smooth curve joining p and q . Let $I \subset [0, 1]$ be a maximal interval such that

$$\delta(\gamma(t)) < \min\{\delta(p), \delta(q), \varepsilon_0\}, \quad \forall t \in I. \quad (79)$$

In particular, $\gamma(I) \subseteq U \simeq (0, \varepsilon_0) \times Z$, with $g = dx^2 + h(x)$, where $h(x)$ is a one-parameter family of smooth metrics on Z . Since $\text{Hess}(\delta) \leq 0$, and $\delta(x, z) = x$, it follows that $x \mapsto h(x)$ is non-increasing. Thus, replacing on I the curve $\gamma(t) = (x(t), z(t))$ with its projection $(x(\partial I), z(t))$ will yield a shorter piecewise smooth curve between p and q . It follows that we can restrict to curves such that

$$\delta(\gamma(t)) \geq \min\{\delta(p), \delta(q), \varepsilon_0\}, \quad \forall t \in [0, 1], \quad (80)$$

which are separated from the metric boundary of \mathbb{M} . It follows that for any $p, q \in \mathbb{M}$ there exist a minimizing curve joining them, any such a curve is a Riemannian geodesic, and any such geodesic respects (80).

In particular, if $p, q \in \mathbb{M}_\varepsilon^\infty$ and $0 < \varepsilon < \varepsilon_0$, there exists a minimizing geodesic of \mathbb{M} joining them, which is entirely contained in $\mathbb{M}_\varepsilon^\infty$. Taking into account the definition of injectivity radius of a manifold with boundary, the proof of the classical Klingenberg Lemma (cf. [16, Ch. 5]) holds unchanged, yielding

$$\text{inj}(\mathbb{M}_\varepsilon^\infty) \geq \min \left\{ \frac{\pi}{\sqrt{K_\varepsilon}}, \frac{\ell_\varepsilon}{2} \right\}. \quad (81)$$

Here $K_\varepsilon = C/\varepsilon^2$ is the upper bound on the sectional curvature of $\mathbb{M}_\varepsilon^\infty$, and ℓ_ε is the shortest simple closed geodesic in $\mathbb{M}_\varepsilon^\infty$.

Let $\gamma : [0, 1] \rightarrow \mathbb{M}$ be such a shortest closed geodesic. Let $\gamma(t_0)$ be a point of closest distance from the metric boundary, and assume now that the convexity assumption in (b) is strict. If $t_0 < \varepsilon_0$, we have

$$(\delta \circ \gamma)''(t_0) = \text{Hess}(\delta)(\dot{\gamma}(t_0), \dot{\gamma}(t_0)) < 0. \quad (82)$$

This is a contradiction. It follows that $\delta(\gamma(t)) \geq \varepsilon_0$ for all $t \in [0, 1]$, and the length of the closed geodesic in (81) does not depend on ε . We conclude by (81).

If the convexity in (b) is not strict, we avoid the contradiction only if γ lies in a level set of δ , that is $\gamma(t) = (\eta, \hat{\gamma}(t))$, for some $\eta \in (\varepsilon, \varepsilon_0)$. Assume in this case that the metric is of warped product type on the neighborhood $U \simeq (0, \varepsilon_0) \times Z$, that is

$$g = dx^2 + f^2(x)\hat{h}, \quad f : (0, \varepsilon_0) \rightarrow \mathbb{R}, \quad (83)$$

where \hat{h} is a fixed Riemannian metric on Z . It follows that $\hat{\gamma} : [0, 1] \rightarrow Z$ is a closed geodesic in $(Z, f^2(\eta)\hat{h})$. The convexity assumption implies that f is non-increasing, therefore $\ell(\hat{\gamma})$ cannot be smaller than the shortest simple closed geodesic of $(Z, f^2(\varepsilon_0)\hat{h})$, which does not depend on ε . We conclude again by (81). \square

We will need the following simple estimate.

Lemma 3.3. *Let \mathbb{M} be a Riemannian manifold with compact metric completion and satisfying Assumption **A**. Then there exists $C > 0$ such that*

$$\frac{\text{vol}(\mathbb{M}_b^\infty)}{\text{vol}(\mathbb{M}_a^\infty)} \geq \left(\frac{a}{b}\right)^{1/C}, \quad \forall 0 < a \leq b \leq \frac{\varepsilon_0}{2}. \quad (84)$$

Proof. Since close to the metric boundary the metric has the form (5), we have

$$\text{vol}(\mathbb{M}_\varepsilon^\infty) = \int_\varepsilon^{\varepsilon_0} \text{vol}(\partial\mathbb{M}_x^\infty) dx + \text{vol}(\mathbb{M}_{\varepsilon_0}^\infty). \quad (85)$$

The bound on the Hessian of Lemma 3.1 implies that $\Delta\delta \geq -\frac{C(n-1)}{x}$. Hence it holds

$$\frac{d}{dx} \text{vol}(\partial\mathbb{M}_x^\infty) = \int_{\partial\mathbb{M}_x^\infty} \Delta\delta d\sigma_x \geq -\frac{C(n-1)}{x} \text{vol}(\partial\mathbb{M}_x^\infty), \quad \forall x \leq \varepsilon_0. \quad (86)$$

By Gronwall's Lemma, this yields

$$\frac{\text{vol}(\partial\mathbb{M}_x^\infty)}{\text{vol}(\partial\mathbb{M}_\varepsilon^\infty)} \geq \left(\frac{\varepsilon}{x}\right)^{C(n-1)}, \quad \forall x \in [\varepsilon, \varepsilon_0]. \quad (87)$$

Combining (85) with (87) we obtain

$$\frac{\text{vol}(\mathbb{M}_\varepsilon^\infty)}{\text{vol}(\partial\mathbb{M}_\varepsilon^\infty)} \geq \int_\varepsilon^{\varepsilon_0} \left(\frac{\varepsilon}{x}\right)^{C(n-1)} dx = \varepsilon \int_1^{\varepsilon_0/\varepsilon} \left(\frac{1}{x}\right)^{C(n-1)} dx. \quad (88)$$

In particular, there exists $C' > 0$ such that

$$\frac{\text{vol}(\mathbb{M}_\varepsilon^\infty)}{\text{vol}(\partial\mathbb{M}_\varepsilon^\infty)} \geq C'\varepsilon, \quad \forall \varepsilon \leq \varepsilon_0/2. \quad (89)$$

Note that (89) is equivalent to

$$\frac{d}{d\varepsilon} \log \text{vol}(\mathbb{M}_\varepsilon^\infty) \geq -\frac{1}{C'\varepsilon}, \quad \forall \varepsilon \leq \varepsilon_0/2, \quad (90)$$

which yields (84) upon integration. \square

4 Weyl's asymptotics for singular manifolds

In this section we prove Theorem 1.1, which we recall for the readers convenience.

Theorem 4.1. *Let \mathbb{M} be a n -dimensional Riemannian manifold with compact metric completion and satisfying Assumption **A**. Then there exist $C_\pm > 0$ and $\Lambda > 0$ such that*

$$C_- \leq \frac{N(\lambda)}{\lambda^{n/2} \text{vol}(\mathbb{M}_{1/\sqrt{\lambda}}^\infty)} \leq C_+, \quad \forall \lambda \geq \Lambda. \quad (91)$$

We introduce some notation. For a domain $\Omega \subset \mathbb{M}$, the Friedrichs (or Dirichlet) Laplace-Beltrami operator Δ_Ω^+ is the self-adjoint operator on $L^2(\Omega, d\mu_g)$ associated with the quadratic form

$$Q(u) = \int_\Omega |\nabla u|^2 d\mu_g, \quad (92)$$

with domain $H_0^1(\Omega)$, i.e., the closure of $C_c^\infty(\Omega)$ w.r.t. the norm $\|\cdot\|_1 = \|\cdot\|_{L^2(\Omega, d\mu_g)} + Q(\cdot)^{1/2}$. On the other hand, we let the Neumann Laplace-Beltrami operator Δ_Ω^- be the operator associated with Q with domain $H^1(\Omega)$, i.e., the closure w.r.t. $\|\cdot\|_1$ of the space $C^\infty(\Omega)$ of functions made of the restrictions to Ω of functions in $C_c^\infty(\mathbb{M})$.

Particularly relevant will be the cases $\Omega = \mathbb{M}_a^b$ with $0 \leq a < b \leq \infty$. The next results are proved in Appendix B in a more general setting.

Proposition 4.2 (Compactness of the resolvent). *Let \mathbb{M} be a non-complete Riemannian manifold with compact metric completion and satisfying Assumption **A**. Then the resolvents $(\Delta_\Omega^\pm - z)^{-1}$ of the Dirichlet and Neumann Laplace-Beltrami operators are compact for any $z > 0$, where $\Omega = \mathbb{M}_a^b$ for $0 \leq a < b \leq \infty$.*

In particular, the spectrum of Δ_Ω^\pm is discrete. We denote by $N_{[a,b]}^\pm(\lambda)$ the corresponding Weyl's counting functions. The following instance of Dirichlet-Neumann bracketing holds as a consequence of the min-max principle (see [23, p. 407]).

Proposition 4.3 (Dirichlet-Neumann bracketing). *Let \mathbb{M} be a Riemannian manifold with compact metric completion and satisfying Assumption **A**. Then, for any sequence $0 = a_0 < a_1 < \dots < a_{m+1} = \infty$, we have*

$$\sum_{i=0}^m N_{[a_i, a_{i+1}]}^-(\lambda) \leq N(\lambda) \leq \sum_{i=0}^m N_{[a_i, a_{i+1}]}^+(\lambda), \quad \forall \lambda \geq 0. \quad (93)$$

In order to discard the contributions to $N(\lambda)$ of the regions near the metric boundary, we need the following Lemma. It is an immediate consequence of the min-max principle and the Hardy inequality given by Proposition **B.1**.

Lemma 4.4 (Estimates close to the singularity). *Let \mathbb{M} be a Riemannian manifold with compact metric completion and satisfying Assumption **A**. Then, for $0 < \varepsilon < \varepsilon_0/2$, it holds*

$$N_{[0, \varepsilon]}^\pm(\lambda) = 0, \quad \forall \lambda < \frac{1}{8\varepsilon^2}. \quad (94)$$

We can now prove Theorem **4.1**. The argument consists in the following steps:

1. Apply Proposition **4.3** to the decomposition $\mathbb{M}_0^\varepsilon \cup \mathbb{M}_\varepsilon^\infty$, for small $\varepsilon > 0$.
2. Use Theorem **2.5** to evaluate $N_{[\varepsilon, \infty]}^\pm(\lambda)$ with an explicit remainder term.
3. Relate ε to λ in such a way that the contribution of $N_{[0, \varepsilon(\lambda)]}(\lambda)$ is negligible, thanks to Lemma **4.4**, and the remainder term in $N_{[\varepsilon(\lambda), \infty]}(\lambda)$ is controlled as $\lambda \rightarrow \infty$.

Proof of Theorem 4.1. Let $0 < \varepsilon < \varepsilon_0/2$. We split \mathbb{M} into two parts $\mathbb{M} = \mathbb{M}_0^\varepsilon \cup \mathbb{M}_\varepsilon^\infty$. Thanks to Lemma **3.1** and Theorem **2.5**, there exists $C > 0$ such that

$$\left| \frac{(2\pi)^n}{\omega_n \text{vol}(\mathbb{M}_\varepsilon^\infty) \lambda^{n/2}} N_{[\varepsilon, \infty]}^\pm(\lambda) - 1 \right| \leq \frac{C}{\log(\chi(\lambda) + 1)}, \quad \forall \lambda > 0, \quad (95)$$

where $\chi(\lambda)$ is given in (71). By our assumptions, there exists a constant $b > 0$, depending only on the dimension, such that $\lambda_0 \leq b/\varepsilon^2$ (for simplicity, we set $b = 1$ in the following). In particular, we have

$$\chi(\lambda) \geq \min \left\{ (\varepsilon^2 \lambda)^{1/2}, (\varepsilon^2 \lambda)^{n/2} \right\}. \quad (96)$$

Our aim is to let $\varepsilon \rightarrow 0$ as $\lambda \rightarrow \infty$, while keeping $\varepsilon^2 \lambda$ bounded away from zero in order to keep the remainder term under control. Hence, let a be a positive constant and set $\varepsilon = \varepsilon_a(\lambda)$ where

$$\varepsilon_a(\lambda) := \frac{1}{\sqrt{a\lambda}}, \quad a > 0. \quad (97)$$

In this case, the remainder term in (95) is bounded by a constant, depending only on the dimension and on a , which can be made arbitrarily small as $a \rightarrow 0$.

In the rest of the proof, by considering two cases in which a is either large or small, we obtain the upper and lower bound for $N(\lambda)$, respectively.

We start with the upper bound. Choose $a_+ > 8$ and set $\varepsilon = \varepsilon_{a_+}(\lambda)$ as described above. Then, Lemma 4.4 yields $N_{[0,\varepsilon]}^\pm(\lambda) = 0$ for $\lambda \geq \Lambda := 4/(\varepsilon_0^2 a_+)$. Hence, by Neumann bracketing (i.e., the r.h.s. of Proposition 4.3) we obtain that there exists $C_+ > 0$ such that for all $\lambda \geq \Lambda$ it holds

$$N(\lambda) \leq N_{[0,\varepsilon]}^+(\lambda) + N_{[\varepsilon,\infty]}^+(\lambda) \leq N_{[\varepsilon,\infty]}^+(\lambda) \leq C_+ \lambda^{n/2} \text{vol} \left(\mathbb{M}_{1/\sqrt{a_+\lambda}}^\infty \right). \quad (98)$$

For the lower bound, we neglect the boundary contribution, since $N_{[0,\varepsilon]}^-(\lambda) \geq 0$. By Dirichlet bracketing (i.e., the l.h.s. of Proposition 4.3), we have

$$N(\lambda) \geq N_{[0,\varepsilon]}^-(\lambda) + N_{[\varepsilon,\infty]}^-(\lambda) \geq N_{[\varepsilon,\infty]}^-(\lambda). \quad (99)$$

Choose $\varepsilon = \varepsilon_{a_-}(\lambda)$, with a_- sufficiently small in such a way that the remainder term in (95) is smaller than 1. We deduce that there exists a constant $C_- > 0$ such that

$$N(\lambda) \geq N_{[\varepsilon,\infty]}^-(\lambda) \geq C_- \lambda^{n/2} \text{vol} \left(\mathbb{M}_{1/\sqrt{a_-\lambda}}^\infty \right), \quad (100)$$

provided that $\lambda \geq \Lambda_- := 4/(\varepsilon_0^2 a_-)$.

To conclude the proof, we apply Lemma 3.3 to (98) and (100). \square

Remark 4.1. The proof of Theorem 4.1 shows that the estimate of Theorem 2.2 (and in turn Theorem 4.1 itself) cannot be improved. Indeed, suppose that we are able to deduce a better remainder term, so that by setting $\varepsilon(\lambda) := (a\lambda)^{-1/2}$ the remainder term of Theorem 2.2 is negligible, and not simply bounded, as $\lambda \rightarrow \infty$. For the upper bound, arguing as above, we need to choose $a = a_+ > 8$, and we obtain

$$\limsup_{\lambda \rightarrow \infty} \frac{N(\lambda)}{\lambda^{n/2} \text{vol}(\mathbb{M}_{1/\sqrt{\lambda}}^\infty)} \leq \frac{\omega_n}{(2\pi)^n} a_+^{1/2C}, \quad (101)$$

where we used Lemma 3.3 to derive that $\text{vol}(\mathbb{M}_{1/\sqrt{a_+\lambda}}^\infty)/\text{vol}(\mathbb{M}_{1/\sqrt{\lambda}}^\infty) \leq a_+^{1/2C}$. Hence, the best upper bound in (101) is obtained for $a_+ = 8$. For the lower bound, we obtain

$$\liminf_{\lambda \rightarrow \infty} \frac{N(\lambda)}{\lambda^{n/2} \text{vol}(\mathbb{M}_{1/\sqrt{\lambda}}^\infty)} \geq \frac{\omega_n}{(2\pi)^n} a_-^{1/2C}. \quad (102)$$

In this case, there is no constraint on a_- , obtaining a contradiction with (101).

5 Slowly varying volumes

A continuous function $\ell : \mathbb{R}_+ \rightarrow \mathbb{R}_+$ is slowly varying at infinity in the sense of Karamata (cf. [7]) if, for all $a > 0$, it holds

$$\lim_{x \rightarrow \infty} \frac{\ell(ax)}{\ell(x)} = 1. \quad (103)$$

One can show that the above limit is uniform for a in compact intervals.

Example 5.1. Examples of slowly varying functions, cf. [7], are $\log x$, the iterates $\log_k x = \log_{k-1} \log x$, rational functions with positive coefficients formed with the $\log_k x$. Non-logarithmic examples are

$$\exp((\log x)^{\alpha_1} \dots (\log_k x)^{\alpha_k}), \quad 0 < \alpha_i < 1. \quad (104)$$

Clearly, any function with finite limit at infinity is slowly varying.

5.1 Exact Weyl's law for slowly varying volumes

The main result of this section is an *exact* Weyl's law for singular structures satisfying Assumption **A** and an additional volume growth assumption.

Theorem 5.1. *Let \mathbb{M} be an n -dimensional Riemannian manifold with compact metric completion and satisfying Assumption **A**. Assume, moreover, that the function*

$$v(\lambda) = \text{vol} \left(\mathbb{M}_{1/\sqrt{\lambda}}^\infty \right) \quad (105)$$

is slowly varying. Then, we have

$$\lim_{\lambda \rightarrow \infty} \frac{N(\lambda)}{\lambda^{n/2} v(\lambda)} = \frac{\omega_n}{(2\pi)^n}. \quad (106)$$

Proof. We prove that

$$\frac{\omega_n}{(2\pi)^n} \leq \liminf_{\lambda \rightarrow \infty} \frac{N(\lambda)}{\lambda^{n/2} v(\lambda)} \leq \limsup_{\lambda \rightarrow \infty} \frac{N(\lambda)}{\lambda^{n/2} v(\lambda)} \leq \frac{\omega_n}{(2\pi)^n}. \quad (107)$$

The proof of the lower bound starts as in the proof of Theorem 4.1, i.e., by splitting $\mathbb{M} = \mathbb{M}_\varepsilon^\infty \cup \mathbb{M}_0^\varepsilon$, for $0 < \varepsilon < \varepsilon_0/2$. We have

$$N(\lambda) \geq N_{[0, \varepsilon]}^- + N_{[\varepsilon, \infty]}^-(\lambda) \geq N_{[\varepsilon, \infty]}^-(\lambda). \quad (108)$$

Choose $a > 0$ small and let $\varepsilon = 1/\sqrt{a\lambda}$. From (95) we deduce the existence of a constant $C(a)$, tending to 0 as $a \rightarrow 0$, such that

$$N(\lambda) \geq N_{[\varepsilon, \infty]}^-(\lambda) \geq \frac{\omega_n}{(2\pi)^n} \lambda^{n/2} v(a\lambda) (1 + C(a)). \quad (109)$$

We now use the fact that $v(\lambda)$ is slowly varying to obtain

$$\liminf_{\lambda \rightarrow \infty} \frac{N(\lambda)}{\lambda^{n/2} v(\lambda)} \geq \frac{\omega_n}{(2\pi)^n} (1 + C(a)). \quad (110)$$

By letting $a \rightarrow 0$ we conclude the proof of the lower bound.

The upper bound is more delicate. We split \mathbb{M} into three parts:

$$\mathbb{M} = \mathbb{M}_0^{\varepsilon_1} \cup \mathbb{M}_{\varepsilon_1}^{\varepsilon_2} \cup \mathbb{M}_{\varepsilon_2}^\infty, \quad 0 < \varepsilon_1 < \varepsilon_2 < \varepsilon_0/2. \quad (111)$$

Consider $a < 1$ small and let

$$\varepsilon_1(\lambda) := \frac{1}{10\sqrt{\lambda}}, \quad \varepsilon_2(\lambda) := \frac{1}{\sqrt{a\lambda}}. \quad (112)$$

The factor 10 above has been chosen in order to be able to apply Lemma 4.4, whence $N_{[0, \varepsilon_1(\lambda)]}^+(\lambda) = 0$. By Neumann bracketing, we obtain

$$N(\lambda) \leq N_{[\varepsilon_1(\lambda), \varepsilon_2(\lambda)]}^+(\lambda) + N_{[\varepsilon_2(\lambda), \infty]}^+(\lambda). \quad (113)$$

In Proposition 5.2 below, we show that, thanks to the slowly varying assumption, the first term in (113) gives a negligible contribution at infinity, more precisely

$$\lim_{\lambda \rightarrow \infty} \frac{N_{[\varepsilon_1(\lambda), \varepsilon_2(\lambda)]}^+(\lambda)}{\lambda^{n/2} v(\lambda)} = 0. \quad (114)$$

On the other hand, applying Theorem 2.5 to $\mathbb{M}_{\varepsilon_2(\lambda)}^\infty$, we obtain that for all $\lambda > 0$

$$N_{[\varepsilon_2(\lambda), \infty]}^+(\lambda) \leq \frac{\omega_n}{(2\pi)^n} \text{vol} \left(\mathbb{M}_{\varepsilon_2(\lambda)}^\infty \right) \lambda^{n/2} (1 + C(a)), \quad (115)$$

where $C(a) \rightarrow 0$ as $a \rightarrow 0$. Since v is slowly varying, we have

$$\text{vol} \left(\mathbb{M}_{\varepsilon_2(\lambda)}^\infty \right) \sim v(\lambda). \quad (116)$$

Putting together the contributions from (114) and (115), we finally get

$$\limsup_{\lambda \rightarrow \infty} \frac{N(\lambda)}{\lambda^{n/2} v(\lambda)} \leq \frac{\omega_n}{(2\pi)^n} (1 + C(a)). \quad (117)$$

Letting $a \rightarrow 0$, we have $C(a) \rightarrow 0$, which completes the proof. \square

The following proposition estimates the number of eigenvalues in the intermediate strip $\mathbb{M}_{\varepsilon_1}^{\varepsilon_2}$ close to the singularity. Note that we cannot apply Theorem 2.5 to $\mathbb{M}_{\varepsilon_1}^{\varepsilon_2}$ since the latter does not have convex boundary.

Proposition 5.2. *Let \mathbb{M} be an n -dimensional Riemannian manifold with compact metric completion and satisfying Assumption A. There exists a constant $C > 0$ such that, for any $0 < \varepsilon_1 < \varepsilon_2 < \varepsilon_0/2$, it holds*

$$N_{[\varepsilon_1, \varepsilon_2]}^\pm(\lambda) \leq C \text{vol}(Z_{\varepsilon_1}) (\varepsilon_2 - \varepsilon_1) \left(\frac{\varepsilon_2}{\varepsilon_1} \right)^{C/2} \lambda^{n/2}, \quad \forall \lambda > \frac{(\varepsilon_1/\varepsilon_2)^C}{\min\{\varepsilon_1^2, (\varepsilon_2 - \varepsilon_1)^2\}}. \quad (118)$$

Assume furthermore that $v(\lambda)$ is slowly varying, and choose $\varepsilon_1 = \frac{1}{10\sqrt{\lambda}}$ and $\varepsilon_2 = \frac{1}{\sqrt{a\lambda}}$ as in (112), with $a < 1$ sufficiently small. Then we have

$$\lim_{\lambda \rightarrow \infty} \frac{N_{[\varepsilon_1(\lambda), \varepsilon_2(\lambda)]}^\pm(\lambda)}{\lambda^{n/2} v(\lambda)} = 0. \quad (119)$$

Proof. Let $I = [\varepsilon_1, \varepsilon_2]$. Close to the metric boundary, one has that $\mathbb{M}_{\varepsilon_1}^{\varepsilon_2} = I \times Z$ and

$$g = dx^2 + h(x), \quad (120)$$

where $h(x)$ is a one-parameter family of Riemannian metrics on the fixed closed hypersurface Z . It is sufficient to prove the proposition for the Neumann case. Let Q and R be the corresponding quadratic form and Rayleigh quotient, i.e.,

$$Q(u) = \int_{I \times Z} |\nabla^g u|^2 d\mu_g, \quad R(u) = \frac{Q(u)}{\|u\|_{L^2(I \times Z, d\mu_g)}^2}, \quad u \in C^\infty(I \times Z). \quad (121)$$

The idea is to control the Rayleigh quotient in terms of the one of a simpler metric. To this purpose, let g_1 be the metric on $I \times Z$ obtained by freezing $x = \varepsilon_1$, that is

$$g_1 = dx^2 + h(\varepsilon_1). \quad (122)$$

Fix a smooth measure dz on Z . Observe that $d\mu_g = e^{2\theta(x,z)} dx dz$ for a smooth function $\theta : I \times Z \rightarrow \mathbb{R}$, and that $\text{Tr Hess}(\delta) = 2\partial_x \theta$. Therefore, since $\delta(x, z) = x$ on $I \times Z$, we have

$$-\frac{C}{x} \leq 2\partial_x \theta \leq 0, \quad (123)$$

for some constant $C > 0$ depending only on n . It follows that on $I \times Z$ it holds

$$\left(\frac{\varepsilon_1}{\varepsilon_2}\right)^C d\mu_{g_1} \leq d\mu_g \leq d\mu_{g_1}, \quad (124)$$

as measures. Inequality (124) will be used to estimate the behaviour of the measure in the Rayleigh quotient. For what concerns the norm of the gradient, observe that, by convexity, the family $x \mapsto h(x)$ is decreasing, which implies

$$|\nabla^g u|^2 \geq |\nabla^{g_1} u|^2. \quad (125)$$

It follows from (124) and (125) that, denoting with R_1 the Rayleigh quotient of the Riemannian manifold $(I \times Z, g_1)$, one has

$$R(u) \geq \left(\frac{\varepsilon_1}{\varepsilon_2}\right)^C R_1(u), \quad \forall u \in C^\infty(I \times Z). \quad (126)$$

By the min-max characterization of eigenvalues, it follows that

$$N_{(I \times Z, g)}^+(\lambda) \leq N_{(I \times Z, g_1)}^+ \left(\left(\frac{\varepsilon_2}{\varepsilon_1}\right)^C \lambda \right), \quad \forall \lambda > 0. \quad (127)$$

We will estimate the r.h.s. of (127) through Theorem 2.5. To do so, notice that $(I \times Z, g_1)$ is the product of (I, dx^2) and (Z, h_1) , with $h_1 := h(\varepsilon_1)$. As such, it is a compact Riemannian manifold with totally geodesic, and thus convex, boundary. Its sectional curvature is bounded by the one of the factor (Z, h_1) . By Gauss' equation, there exists a constant C (depending only on the constants appearing in Assumption **A** and hence not on the choice of ε_1 and ε_2) such that

$$|\text{Sec}(I \times Z, g_1)| \leq |\text{Sec}(Z, h_1)| \leq \frac{C}{\varepsilon_1^2}. \quad (128)$$

Furthermore, the injectivity radius from the boundary of $(I \times Z, g_1)$ is

$$\text{inj}_\partial(I \times Z, g_1) = \frac{1}{2}(\varepsilon_2 - \varepsilon_1). \quad (129)$$

Finally, the injectivity radius of $(I \times Z, g_1)$ is equal to the one of (Z, h_1) . The latter is a submanifold of bounded second fundamental form in a Riemannian manifold of bounded sectional curvature and injectivity radius. Its injectivity radius can be bounded from below in terms of the aforementioned quantities and its distance from the metric boundary, as stated in Lemma A.5. Using Assumption **A**, we deduce the existence of $C > 0$, not depending on the choice of $\varepsilon_1, \varepsilon_2$, such that

$$\text{inj}(I \times Z, g_1) = \text{inj}(Z, h_1) \geq C^{-1}\varepsilon_1. \quad (130)$$

We can now apply Theorem 2.5 to $(I \times Z, g_1)$, yielding the existence of a constant $C > 0$, not depending on the choice of $\varepsilon_1, \varepsilon_2$, such that

$$N_{[\varepsilon_1, \varepsilon_2]}^+(\lambda) \leq C \text{vol}(I \times Z, g_1) \left(\left(\frac{\varepsilon_2}{\varepsilon_1}\right)^C \lambda \right)^{n/2}, \quad \forall \lambda > \frac{(\varepsilon_1/\varepsilon_2)^C}{\min\{\varepsilon_1^2, (\varepsilon_2 - \varepsilon_1)^2\}}. \quad (131)$$

This proves the first part of the proposition, as $\text{vol}(I \times Z, g_1) = \text{vol}(Z_{\varepsilon_1})(\varepsilon_2 - \varepsilon_1)$.

To prove the second part of the statement, letting $Z_x = \{\delta = x\}$ and recalling the definition $v(1/x^2) = \text{vol}(\mathbb{M}_x^\infty)$, we deduce

$$\text{vol}(\mathbb{M}_x^\infty) = \int_x^\infty \text{vol}(Z_x) dx \quad \Rightarrow \quad \text{vol}(Z_{\varepsilon_1}) = \frac{v'(1/\varepsilon_1^2)}{2\varepsilon_1^3}. \quad (132)$$

Let now choose $\varepsilon_1 = \frac{1}{10\sqrt{\lambda}}$ and $\varepsilon_2 = \frac{1}{\sqrt{a\lambda}}$, for $a < 1$. Notice that for a sufficiently small, depending on the given value of C , then the condition for the validity of (131) is verified for all λ . We have, in this case, by possibly renaming the constants (which may now depend on a),

$$\frac{N_{[\varepsilon_1(\lambda), \varepsilon_2(\lambda)]}^+(\lambda)}{\lambda^{n/2}v(\lambda)} \leq C(a) \frac{\lambda v'(100\lambda)}{v(\lambda)}, \quad \forall \lambda > 0. \quad (133)$$

Since v is slowly varying the r.h.s. tends to zero (use Lemma 5.3 given below). \square

The next result is an application of [7, Thm. 1.7.2 and Prop. 1.5.8], see also [36, Thm. 2].

Lemma 5.3. *Let $v : \mathbb{R}_+ \rightarrow \mathbb{R}_+$ be a slowly varying function of class C^1 such that $\lambda \mapsto \lambda^a v'(\lambda)$ is monotone for some $a \geq 0$. Then,*

$$\lim_{\lambda \rightarrow \infty} \frac{\lambda v'(\lambda)}{v(\lambda)} = 0. \quad (134)$$

5.2 Metrics with prescribed Weyl's law

We prove the following converse to Theorem 5.1.

Theorem 5.4. *Let N be an n -dimensional compact manifold, $S \subset N$ be a closed submanifold, and $v : \mathbb{R}_+ \rightarrow \mathbb{R}_+$ be a non-decreasing slowly varying function. Then, there exists a Riemannian structure on N , singular at S , such that*

$$\lim_{\lambda \rightarrow \infty} \frac{N(\lambda)}{\lambda^{n/2}v(\lambda)} = \frac{\omega_n}{(2\pi)^n}. \quad (135)$$

Proof. The idea is to build a non complete Riemannian structure on $N \setminus S$, of warped-product type near S , with respect to some function f , which has to be chosen carefully, so that $\text{vol}(M_{1/\sqrt{\lambda}}) \sim v(\lambda)$ and Assumption **A** is satisfied. Indeed, this will allow to apply Theorem 5.1, and thus to obtain (135). To this purpose, one needs to control in a precise way the asymptotic behaviour of the quantities $\lambda v''(\lambda)/v'(\lambda)$ and $\lambda v^{(3)}(\lambda)/v'(\lambda)$; However, this is not possible for general slowly varying functions.² We tackle this problem by exploiting the theory of regular variation to replace v with a more tame slowly varying function with the desired asymptotics at infinity. We refer to [7, Ch. 1, 3] for definition of the de Haan class Π , and the smooth de Haan class $S\Pi$, both strict subsets of the family of slowly varying functions.

By [24, Appendix B], any non-decreasing slowly varying function v is asymptotic to a de Haan function, which we still denote by $v \in \Pi$. Furthermore, by a smoothing result [7, Thm. 3.7.7], any de Haan function is asymptotic to a smooth one, which we still denote with the same symbol $v \in S\Pi$ and which verifies that

$$\lim_{\lambda \rightarrow \infty} \frac{\lambda v^{(1+m)}(\lambda)}{v'(\lambda)} = (-1)^m m!, \quad \forall m \in \mathbb{N}. \quad (136)$$

²For all examples of monotone slowly varying function given at the beginning of this section, these quantities actually admit a finite limit. An example of strictly monotone slowly varying function for which $\lambda v''(\lambda)/v'(\lambda)$ is unbounded and does not have a limit is $v(\lambda) = 2 \log \lambda + \sin \log \lambda$.

Moreover, it follows from the proof of [7, Thm. 3.7.7] that $v'(\lambda) > 0$ for sufficiently large λ . Thus, we can assume that v itself is smooth, strictly increasing, and satisfies (136).

We proceed with the construction in the case where S is a submanifold of codimension $\neq 1$ or it is one-sided. The case of a two-sided hypersurface follows with trivial modifications. Choose a tubular neighborhood $U' \subset N$ of S such that $U' \setminus S = (0, 2) \times Z$, for a closed hypersurface Z . Fix a metric \hat{g} on Z and set

$$g|_{U'} = dx^2 + f^2 \hat{g}, \quad (137)$$

where $f : (0, 2) \rightarrow \mathbb{R}_+$ is a smooth function to be chosen later and meant to explode as x tends to 0. Extend g to a smooth Riemannian metric on the whole $\mathbb{M} := N \setminus S$, by preserving (137) on the neighborhood $U = (0, 1) \times Z$.

By construction, (\mathbb{M}, g) has compact metric completion and $\delta(x, z) = x$ for $(x, z) \in (0, 1) \times Z$. In particular, the level sets of δ close to the metric boundary are diffeomorphic to Z and (a) of Assumption **A** is verified. Define f in such a way that $\text{vol}(M_{1/\sqrt{\lambda}}) \sim v(\lambda)$, by setting

$$f(x)^{n-1} = \frac{2}{\text{vol}(Z, \hat{g})} \frac{v'(1/x^2)}{x^3}, \quad x \in (0, 1). \quad (138)$$

Since v is strictly increasing, $f > 0$ and its only singularity is at $x = 0$. Since $v \in SII$, we have that $\lambda v'(\lambda)$ is slowly varying at infinity and $f(x) \rightarrow +\infty$ as $x \rightarrow 0$.

Let us verify (\mathbb{M}, g) satisfies Assumption **A**. The projection on the first factor $\pi : (0, 1) \times Z \rightarrow (0, 1)$ of the warped product (137) is a Riemannian submersion with leaves (Z, \hat{g}) . By O'Neill formulas [6, 9.29, 9.104], the sectional curvatures are:

$$K(U, V) = \frac{1}{f^2} \hat{K}(U, V) - \left(\frac{f'}{f} \right)^2, \quad (139)$$

$$K(X, U) = -\frac{f''}{f}, \quad (140)$$

$$K(X, Y) = 0. \quad (141)$$

Here, U, V are orthonormal vectors tangent to the fibers Z , X, Y are unit vectors tangent to the base $(0, 1)$, and \hat{K} is the sectional curvature of (Z, \hat{g}) . Finally, the hypersurfaces $\{\delta = x\}$, for $x \in (0, 1)$, have as their second fundamental form

$$\text{Hess}(\delta)(U, V) = \frac{f'}{f} g(U, V). \quad (142)$$

It is then clear that the quantities controlling the behavior of the geometric invariants of g close to the metric boundary (i.e. as $x \rightarrow 0$) are f'/f and f''/f . Thanks to the fact that v is a de Haan function, we are able to compute their asymptotics as $x \rightarrow 0$. By (136), $h_m(x) \rightarrow (-1)^m m!$ as $|x| \rightarrow 0$, where

$$h_m(x) := \frac{v^{(m+1)}(1/x^2)}{x^2 v'(1/x^2)}, \quad m \geq 1. \quad (143)$$

Using (138), we have, as $x \rightarrow 0$,

$$\frac{f'(x)}{f(x)} = -\frac{3 + 2h_1(x)}{(n-1)x} \sim -\frac{1}{(n-1)x}, \quad (144)$$

$$\frac{f''(x)}{f(x)} = \frac{3n + 6 - 4(n-2)h_1(x)^2 + 4(n-1)h_2(x) + 6(n+1)h_1(x)}{(n-1)^2 x^2} \sim \frac{n}{(n-1)^2 x^2}. \quad (145)$$

Hence, Assumption **A** is verified and we can apply Theorem 5.1 to (\mathbb{M}, g) . \square

Remark 5.1. The Laplace-Beltrami operator of the structure built in the proof of Theorem 5.4, with domain $C_c^\infty(N \setminus S)$, is essentially self-adjoint in $L^2(N, d\mu_g)$. Indeed, $\Delta\delta = (n-1)f'/f$, and as a consequence of the curvature estimates obtained above one has

$$V_{\text{eff}} := \left(\frac{\Delta\delta}{2}\right)^2 + \left(\frac{\Delta\delta}{2}\right)' \geq \frac{3}{4\delta^2} \left(1 - \frac{1}{\log \delta^{-1}}\right), \quad (146)$$

for small δ , where $'$ denotes the derivative with respect to $\nabla\delta$. This estimate allows to apply the essential-self adjointness criterion of [47], combined with the improvement of the constant obtained in [43]. We omit the details.

6 Concentration of eigenfunctions

Under the assumptions of Theorem 4.1, it holds that $N(\lambda) \asymp \lambda^{n/2} \text{vol}(\mathbb{M}_{1/\sqrt{\lambda}}^\infty)$. Here, $f(\lambda) \asymp g(\lambda)$ means that the ratio $f(\lambda)/g(\lambda)$ is uniformly bounded above and below by positive constants for λ large enough. In this section, we show that under the additional assumption $\text{vol}(\mathbb{M}) = \infty$, eigenfunctions concentrate at the metric boundary of \mathbb{M} .

We recall that a subset $S \subseteq \mathbb{N}$ has density $a \in [0, 1]$ if

$$\lim_{\ell \rightarrow \infty} \frac{1}{\ell} \sum_{k=0}^{\ell-1} \mathbb{1}_S(k) = a. \quad (147)$$

Theorem 6.1. *Let \mathbb{M} be an n -dimensional Riemannian manifold such that the Friedrichs Laplace-Beltrami operator Δ has discrete spectrum, and*

$$\lim_{\lambda \rightarrow \infty} \frac{N(\lambda)}{\lambda^{n/2}} = \infty. \quad (148)$$

Let $\{\phi_i\}_{i \in \mathbb{N}}$ be a complete set of normalized eigenfunctions of $-\Delta$, associated with eigenvalues λ_i , arranged in non-decreasing order. Then, there exists a density one subset $S \subseteq \mathbb{N}$ such that for any compact U it holds

$$\lim_{\substack{i \rightarrow \infty \\ i \in S}} \int_U |\phi_i|^2 d\mu_g = 0. \quad (149)$$

Proof. Fix a compact set U . Let E denote the heat kernel of Δ and, for $i \in \mathbb{N}$, $a_i(U) := \int_U |\phi_i|^2 d\mu_g$. Since the heat kernel is local, we have

$$t^{n/2} \sum_{i=1}^{\infty} e^{-t\lambda_i} a_i(U) = t^{n/2} \int_U E(t, q, q) d\mu_g(q) \sim c, \quad t \rightarrow 0, \quad (150)$$

for some constant $c > 0$. By the standard Karamata theorem, it holds

$$\sum_{\lambda_i \leq \lambda} a_i(U) \sim \frac{c}{\Gamma(n/2 + 1)} \lambda^{n/2}, \quad \lambda \rightarrow \infty. \quad (151)$$

By our assumption on $N(\lambda)$, it holds then

$$\lim_{\ell \rightarrow \infty} \frac{1}{\ell} \sum_{i=1}^{\ell-1} a_i(U) = 0. \quad (152)$$

By [45, Lemma 6.2], the above statement is equivalent to the existence of a density one subset $S_U \subseteq \mathbb{N}$ such that

$$\lim_{\substack{i \rightarrow \infty \\ i \in S_U}} a_i(U) = 0. \quad (153)$$

The subset $S_U \subset \mathbb{N}$ depends on the choice of U but we next build a subset S having the same property and which does not depend on U , as claimed in the statement. We use ideas similar to those in the proof of [45, Lemma 6.2] and [17, Sec. 5].

Let $\{U_m\}_{m \in \mathbb{N}}$ be an exhaustion of \mathbb{M} by compact subsets, i.e., each U_m is compact, $U_{m+1} \supset U_m$, and $U_m \rightarrow \mathbb{M}$ as $m \rightarrow \infty$. Let $S_m \subset \mathbb{N}$ a density one subset built as above, such that

$$\lim_{\substack{i \rightarrow \infty \\ i \in S_m}} a_i(U_m) = 0. \quad (154)$$

Without loss of generality, we can assume that $S_{m+1} \subseteq S_m$ (if this is not the case, we take in place of S_m the set $\tilde{S}_m = \cap_{i \leq m} S_i$. Indeed \tilde{S}_m is a density-one subset of \mathbb{N} with the required properties, and such that (154) holds). By the density one property, there exists $i_1 < i_2 < \dots$ such that

$$\frac{1}{\ell} \sum_{k=0}^{\ell-1} \mathbb{1}_{S_m}(k) \geq 1 - \frac{1}{m}, \quad \forall \ell \geq i_{m-1}. \quad (155)$$

Then, the required set S can be taken as

$$S := \bigcup_{m=1}^{\infty} S_m \cap [i_m, i_{m+1}), \quad (156)$$

Indeed, if $i_m \leq n < i_{m+1}$ we have

$$\frac{1}{\ell} \sum_{k=0}^{\ell-1} \mathbb{1}_S(k) \geq \frac{1}{\ell} \sum_{k=0}^{\ell-1} \mathbb{1}_{S_m}(k) \geq 1 - \frac{1}{m}, \quad (157)$$

yielding that S has density one.

Notice that, by construction since $S_{m+1} \subseteq S_m$, we have that $S \cap [i_m, \infty) \subseteq S_m$. Therefore, for all $m > 0$, we have

$$\lim_{\substack{i \rightarrow \infty \\ i \in S}} a_i(U_m) = 0. \quad (158)$$

We conclude the proof by noticing that any compact set \bar{U} is contained in some $U_{\bar{m}}$, and we have $a_i(\bar{U}) \leq a_i(U_{\bar{m}})$ for all $i \in \mathbb{N}$. \square

7 Almost-Riemannian structures

We apply our results to a class of structures where the singularity admits a nice local description. This class is modelled on almost-Riemannian structures, introduced in [2]. We provide here an explicit and local definition based on local coordinates. We refer the reader to [47, Sec. 7] for a self-contained presentation close to our approach.

Let N be a connected n -dimensional manifold, and let $S \subset N$ be an embedded hypersurface. We assume to be given a Riemannian metric g on $N \setminus S$ such that, for all $p \in S$, there exist local coordinates $(x, z) \in \mathbb{R} \times \mathbb{R}^{n-1}$ and smooth vector fields

$$X_0 = \partial_x, \quad X_i = \sum_{j=1}^{n-1} a_{ij}(x, z) \partial_{z_j}, \quad (159)$$

which are orthonormal for g outside of S , and such that $\det a_{ij}(x, z) = 0$ if and only if $x = 0$. This is a particular type of singular Riemannian metric on N , called *almost-Riemannian structure* (ARS). Furthermore, we ask that there exists $m \in \mathbb{N}$ such that

$$a_{ij}(x, z) = x^m \hat{a}_{ij}(x, z), \quad \det \hat{a}_{ij}(0, z) \neq 0. \quad (160)$$

In this case, on each local chart, we have

$$X_0 = \partial_x, \quad X_i = x^m \hat{X}_i = x^m \sum_{j=1}^{n-1} \hat{a}_{ij}(x, z) \partial_{z_j}, \quad (161)$$

where $X_0, \hat{X}_1, \dots, \hat{X}_n$ have maximal rank also on the singular region. In particular we can introduce the regularized Riemannian metric \hat{g} in a neighborhood of S as the metric with smooth orthonormal frame given by $\{X_0, \hat{X}_1, \dots, \hat{X}_n\}$. We denote with a hat all the quantities relative to this structure. In particular, the *regularized measure* $\hat{\sigma}(S)$ of S is defined as the surface measure of S with respect to the regularized Riemannian measure.

Definition 7.1. A singular Riemannian structure on an n -dimensional manifold N as above is called a strongly regular ARS of order m .

Equivalently, a strongly regular ARS of order m is an ARS whose Riemannian metric g can be written, in a neighborhood of any point of S , as

$$g = dx^2 + x^{-2m} \hat{h}(x, z), \quad (162)$$

where $\hat{h}(x, z)$ is a positive definite symmetric tensor, well defined also on the singularity.

Remark 7.1. As a consequence of the theory developed in [47], the Laplace-Beltrami operator of a strongly regular ARS is essentially self-adjoint in $L^2(N \setminus S, d\mu_g)$. The same result holds more generally for *regular structures*, introduced in [47], that is, when the condition (160) is replaced by the weaker one

$$\det a_{ij}(x, z) = x^k \phi(x, z), \quad \phi(x, z) \neq 0. \quad (163)$$

7.1 Weyl's law for strongly regular ARS

The restriction of g to $\mathbb{M} = N \setminus S$ is a non-complete Riemannian manifold. The next proposition motivates the relevance of strongly regular ARS.

Proposition 7.2. *Any strongly regular ARS on a compact n -dimensional manifold satisfies Assumption **A**. Furthermore, as $\varepsilon \rightarrow 0$, we have*

$$\text{vol}(\mathbb{M}_\varepsilon^\infty) \sim 2\hat{\sigma}(S) \times \begin{cases} \varepsilon^{-(m(n-1)-1)} & m(n-1) > 1, \\ \log \varepsilon^{-1} & m(n-1) = 1, \end{cases} \quad (164)$$

where $m \in \mathbb{N}$ is the order of the strongly regular ARS.

Proof. The non-complete Riemannian manifold $\mathbb{M} = N \setminus S$ has metric boundary given by one or two copies of S , depending whether the latter is one or two-sided. In the above local coordinates close to S we have $\delta(x, z) = |x|$. If N is compact, δ is smooth in a uniform neighborhood $U = \{\delta < \varepsilon_0\}$ of the metric boundary, i.e., (a) of Assumption **A** is verified.

To compute curvature-type quantities, we adopt the following modified Einstein convention. Latin indices run from $1, \dots, n-1$, and repeated indices are summed on that

range. The index 0 is reserved for the variable x , i.e., $\partial_0 = \partial_x$. The non-vanishing structural functions are given by

$$[X_0, X_i] = c_{0i}^\ell X_\ell, \quad [X_i, X_j] = c_{ij}^\ell X_\ell. \quad (165)$$

Koszul's formula for the Levi-Civita connection in terms of orthonormal frames yields

$$\nabla_i X_j = \Gamma_{ij}^\ell X_\ell + \gamma_{ij} X_0, \quad \nabla_0 X_i = \beta_{i\ell} X_\ell, \quad \nabla_i X_0 = -\gamma_{i\ell} X_\ell, \quad (166)$$

$$\beta_{i\ell} = \frac{1}{2}(c_{0i}^\ell - c_{0\ell}^i), \quad \gamma_{i\ell} = \frac{1}{2}(c_{0\ell}^i + c_{0i}^\ell), \quad \Gamma_{ij}^\ell = \frac{1}{2}(c_{ij}^\ell + c_{\ell j}^i + c_{\ell i}^j). \quad (167)$$

Notice that $\beta = -\beta^*$, $\gamma = \gamma^*$, while $\Gamma_{ij}^\ell = -\Gamma_{i\ell}^j$. From the definition

$$R(X, Y, Z, W) = g(\nabla_X \nabla_Y Z - \nabla_Y \nabla_X Z - \nabla_{[X, Y]} Z, W), \quad (168)$$

we deduce the following formulas for the Riemann tensor

$$R(X_i, X_j, X_k, X_\ell) = \partial_i \Gamma_{jk}^\ell + \Gamma_{jk}^s \Gamma_{is}^\ell - \gamma_{jk} \gamma_{i\ell} - \partial_j \Gamma_{ik}^\ell - \Gamma_{ij}^s \Gamma_{js}^\ell + \gamma_{ik} \gamma_{j\ell} - c_{ij}^s \Gamma_{sk}^\ell, \quad (169)$$

$$R(X_i, X_j, X_k, X_0) = \Gamma_{jk}^\ell \gamma_{i\ell} + \partial_i \gamma_{jk} - \Gamma_{ik}^\ell \gamma_{j\ell} - \partial_j \gamma_{ik} - c_{ij}^s \gamma_{sk}, \quad (170)$$

$$R(X_0, X_i, X_j, X_0) = \partial_0 \gamma_{ij} + \gamma_{i\ell} \beta_{\ell j} + \gamma_{j\ell} \beta_{\ell i} - \gamma_{i\ell} \gamma_{\ell j}, \quad (171)$$

In particular $\text{Sec}(X \wedge Y) = R(X, Y, Y, X)$ for any pair of unit orthogonal vectors X, Y . Furthermore, since $\delta = |x|$, we have

$$\text{Hess}(\delta)(X_i, X_j) = -\text{sgn}(x) \gamma_{ij}. \quad (172)$$

In terms of the matrix a , the structural functions read

$$c_{0i}^\ell = a_{\ell s}^{-1} \partial_0 a_{si}, \quad c_{ij}^\ell = (a_{ri} \partial_r a_{sj} - a_{jr} \partial_r a_{si}) a_{s\ell}^{-1}. \quad (173)$$

Using (173) one obtains

$$c_{0i}^\ell = \frac{m}{x} \mathbb{1}_{i\ell} + \hat{c}_{0i}^\ell, \quad c_{ij}^\ell = x^m \hat{c}_{ij}^\ell, \quad (174)$$

which implies

$$\beta_{ij} = \hat{\beta}_{ij}, \quad \gamma_{ij} = \frac{m}{x} \mathbb{1}_{ij} + \hat{\gamma}_{ij}, \quad \Gamma_{ij}^\ell = x^m \hat{\Gamma}_{ij}^\ell. \quad (175)$$

From (169)-(171) we obtain

$$R(X_i, X_j, X_k, X_\ell) = -\frac{m^2}{x^2} (\mathbb{1}_{jk} \mathbb{1}_{i\ell} - \mathbb{1}_{ik} \mathbb{1}_{j\ell}) + O\left(\frac{1}{|x|}\right), \quad (176)$$

$$R(X_i, X_j, X_k, X_0) = O(1), \quad (177)$$

$$R(X_0, X_i, X_j, X_0) = -\frac{m(m+1)}{x^2} \mathbb{1}_{ij} + O\left(\frac{1}{|x|}\right), \quad (178)$$

and

$$\text{Hess}(\delta)(X_i, X_j) = -\frac{m}{|x|} \mathbb{1}_{ij} + O(1). \quad (179)$$

In particular points (b) and (c) of Assumption **A** are verified, and the convexity condition is strict. In particular, point (d) is valid thanks to Proposition 3.2. Finally, the volume asymptotics follows from a straightforward computation. \square

We can then apply our theory to strongly regular ARS. We recall that the notation $f(\lambda) \asymp g(\lambda)$ means that $f(\lambda)/g(\lambda)$ has finite and positive lim sup and lim inf, as $\lambda \rightarrow \infty$.

Theorem 7.3 (Weyl's law for strongly regular ARS). *Consider the Laplace-Beltrami operator of a strongly regular ARS of order m on an n -dimensional compact manifold. Then, if $(n, m) \neq (2, 1)$, we have*

$$N(\lambda) \asymp \lambda^{(n-1)(m+1)/2}, \quad \lambda \rightarrow \infty. \quad (180)$$

On the other hand, if $(n, m) = (2, 1)$, we have

$$N(\lambda) \sim \frac{|\hat{\sigma}(S)|}{4\pi} \lambda \log \lambda. \quad (181)$$

Proof. By Proposition 7.2, Assumption **A** is verified, and it can be easily seen that the volume function $v(\lambda) = \text{vol}(\mathbb{M}_{1/\sqrt{\lambda}})$ satisfies

$$v(\lambda) \sim 2\hat{\sigma}(S) \times \begin{cases} \lambda^{(m(n-1)-1)/2} & m(n-1) > 1, \\ \log \lambda & m(n-1) = 1. \end{cases} \quad (182)$$

In the first case, the result follows from Theorem 4.1 while, in the second case, $v(\lambda)$ is slowly varying and we can apply Theorem 5.1. \square

7.2 Examples

We conclude this section with two examples. The first one shows that a general non-strongly regular ARS does not satisfy Assumption **A**. In particular, on ARSs all geometric quantities can have an arbitrarily fast polynomial explosion to $\pm\infty$. The second example is an ARS structure that satisfies Assumption **A** but that is not regular.

Example 7.1 (Worst case curvature explosion). Let $k \geq 1$, and consider the structure defined by declaring the following vector fields to be orthonormal

$$X_0 = \partial_x, \quad X_1 = \partial_{z_1} + x\partial_{z_2}, \quad X_2 = x^k\partial_{z_2}, \quad (183)$$

where $(x, z) \in \mathbb{R} \times \mathbb{R}^2$. In other words, $X_i = \sum_j a_{ij}\partial_{z_j}$, for $i = 1, 2$, with

$$a = \begin{pmatrix} 1 & 0 \\ x & x^k \end{pmatrix}. \quad (184)$$

This structure is (strongly) regular. We use the formalism introduced in the proof of Proposition 7.2. In particular, letting $C_{i\ell} = c_{0i}^\ell$, we have

$$C = (a^{-1}\partial_0 a)^* = \begin{pmatrix} 0 & \frac{1}{x^k} \\ 0 & \frac{k}{x} \end{pmatrix}. \quad (185)$$

It follows that

$$\beta = \frac{1}{2}(C - C^*) = \begin{pmatrix} 0 & \frac{1}{2x^k} \\ -\frac{1}{2x^k} & 0 \end{pmatrix}, \quad \text{and} \quad \gamma = \frac{1}{2}(C + C^*) = \begin{pmatrix} 0 & \frac{1}{2x^k} \\ \frac{1}{2x^k} & \frac{k}{x} \end{pmatrix}. \quad (186)$$

Rewriting (171) in this notation, we obtain, for $i = 1, 2$,

$$\text{Sec}(X_0 \wedge X_i) = (\partial_0 \gamma + 2\gamma\beta - \gamma^2)_{ii} = \text{diag} \left(-\frac{3}{4x^{2k}}, \frac{1}{4x^{2k}} - \frac{k(k+1)}{x^2} \right). \quad (187)$$

Thus, this structure does not satisfy the curvature assumptions of Assumption **A** as soon as $k \geq 2$. Moreover, by (172), the eigenvalues of $\text{Hess}(\delta)$ in the basis $\{X_1, X_2\}$ are given by $h_\pm = \pm \frac{1}{2|x|^k}(1 + o(1))$ as $x \rightarrow 0$. As a consequence, this ARS never satisfies the convexity assumption of Assumption **A**.

Example 7.2. Let N be a compact 2-dimensional manifold, and $S \simeq \mathbb{S}^1$ be a smooth embedded sub-manifold of N . Equip N with an ARS whose local orthonormal frame, in a neighborhood $U = (-1, 1) \times \mathbb{S}^1$ of S , reads

$$X_0 = \partial_x, \quad X_1 = x \left(x^2 + \sin^2(\theta/2) \right) \partial_\theta. \quad (188)$$

This structure is not regular, since (160) is not satisfied uniformly for $\theta \in \mathbb{S}^1$. Nevertheless, by (171) and (172) we have

$$\text{Sec}(X_0 \wedge X_1) = -\frac{2}{x^2} - \frac{10x^2 + 2\sin^2(\theta/2)}{(x^2 + \sin^2(\theta/2))^2} \quad \text{and} \quad \text{Hess}(\delta) = -\frac{1}{|x|} - \frac{2|x|}{x^2 + \sin^2(\theta/2)}. \quad (189)$$

Then, on U it holds

$$-\frac{13}{\delta^2} \leq \text{Sec} \leq 0, \quad \text{and} \quad \text{Hess}(\delta) < 0. \quad (190)$$

In particular, by Proposition 3.2, this singular Riemannian structure satisfies Assumption **A** and thus we can apply Theorem 4.1. To this aim, we only need to estimate the volume function $\lambda \mapsto v(\lambda)$, which can be readily done by integrating the measure $d\mu = \frac{dx d\theta}{|x|(x^2 + \sin^2(\theta/2))}$. Indeed, we have

$$\int_{[\varepsilon, 1] \times \mathbb{S}^1} d\mu = \int_\varepsilon^1 \frac{2\pi}{x^2 \sqrt{x^2 + 1}} dx = \frac{2\pi}{\varepsilon} + O(1), \quad (191)$$

whence $v(\lambda) \sim 4\pi\lambda^{1/2}$. This immediately yields $N(\lambda) \asymp \lambda^{3/2}$ as $\lambda \rightarrow \infty$.

A Auxiliary geometric estimates

On the simply connected n -dimensional Riemannian space form M_K of curvature $K \in \mathbb{R}$, the heat kernel depends only on t and on the distance $r = d(q, p)$, and thus, with a slight abuse of notation, we denote it by $E_K(t, r)$. Here and below, $r \in [0, \pi/\sqrt{K}]$, with the convention that $\pi/\sqrt{K} = +\infty$ if $K = 0$.

Lemma A.1. *For all $T > 0$ there exists a constant $C > 0$, depending only on n and T , such that*

$$|(4\pi t)^{n/2} E_K(t, 0) - 1| \leq C|K|t, \quad \forall t \leq T/|K|. \quad (192)$$

Proof. If $K = 0$, the estimate is trivially verified. Let us consider $K \neq 0$. For a Riemannian metric g and $\alpha > 0$, let $g_\alpha := \alpha^2 g$. Then, $\text{Sec}(g_\alpha) = \alpha^{-2} \text{Sec}(g)$, and $E_{g_\alpha}(t, p, q) = \alpha^{-n} E_g(t/\alpha^2, p, q)$. This immediately implies

$$(4\pi t)^{n/2} E_K(t, r) = (4\pi t|K|)^{n/2} E_{\pm 1}(t|K|, r\sqrt{|K|}), \quad (193)$$

where ± 1 is the sign of K . Moreover, by the Minakshisundaram-Pleijel asymptotics,³ we deduce that, for all $T > 0$, there exist a constant $C > 0$ such that

$$|(4\pi t)^{n/2} E_{\pm 1}(t, 0) - 1| \leq Ct, \quad \forall t \leq T, \quad (194)$$

where C depends only on n and T . This and (193) prove the statement. \square

³We refer to the following simplified statement, valid for any complete n -dimensional Riemannian manifold: for all $T > 0$ and $q \in M$ there exists $C > 0$ such that $|(4\pi t)^{n/2} E(t, q, q) - 1| \leq Ct$, for all $t \in (0, T]$. For a proof in the compact case, see e.g. [48, Prop. 3.23]. The extension to the non compact case is done via a localization argument exploiting (29) and Varadhan's formula.

Lemma A.2. *Let $K \geq 0$, and let $B_K(r)$ be the ball of radius $r \leq \pi/\sqrt{K}$ on the simply connected space form with constant curvature equal to K and dimension n . Then, there exists a constant $C > 0$, depending only on the dimension, such that*

$$\text{vol}(B_K(r)) \geq Cr^n, \quad \forall r \leq \pi/\sqrt{K}. \quad (195)$$

Proof. Since $K \geq 0$, by the Bishop-Gromov inequality, $r \mapsto \text{vol}(B_K(r))/\text{vol}(B_0(r))$ is non-increasing. Hence, the rescaling argument used in the proof of Lemma A.1 yields

$$\frac{\text{vol}(B_K(r))}{\text{vol}(B_0(r))} = \frac{\text{vol}(B_1(r\sqrt{K}))}{\text{vol}(B_0(r\sqrt{K}))} \geq \frac{\text{vol}(B_1(\pi))}{\text{vol}(B_0(\pi))}. \quad (196)$$

To conclude the proof it suffices to observe that $\text{vol}(B_0(r)) = r^n \text{vol}(B_0(1))$. In particular, this yields $C = \text{vol}(B_1(\pi))/\pi^n$. \square

In the next lemma, we show that, for any ball there always exists a spherical sector which points away from the boundary and whose size does not depend on the point. This yields a uniform lower bound to the measure of sufficiently small balls.

Lemma A.3. *Let (M, g) be a complete n -dimensional Riemannian manifold with boundary. Let $H \geq 0$ such that $-H \leq \text{Hess}(d_\partial)$ for $d_\partial < \text{inj}_\partial(M)$ and set*

$$r_0 = \min \left\{ \text{inj}(M), \frac{\text{inj}_\partial(M)}{2}, \frac{1}{H} \right\}. \quad (197)$$

Then, for any $o \in M$ and $r \leq r_0$, there exists an open set $S_o(r) \subset B_o(r)$ such that

- *if $B_o(r)$ does not intersect ∂M , then $S_o(r) = B_o(r)$;*
- *if $B_o(r)$ intersects ∂M , then the closest point of $S_o(r)$ to ∂M is o .*

Let, moreover, $K \geq 0$ be such that $\text{Sec}(g) \leq K$ on $S_o(r)$. Then, there exists a constant $C \in (0, 1/2)$, depending only on n , such that

$$\text{vol}(B_o(r)) \geq \text{vol}(S_o(r)) \geq C \text{vol}(B_K(r)), \quad \forall r \leq r_0. \quad (198)$$

Proof. Fix $r \leq r_0$. If $d_\partial(o) > r$, the ball does not intersect the boundary, and we set $S_o(r) = B_o(r)$. By the curvature upper bound, and since the balls lie within the injectivity radius from their center, we have that their volume is bounded from below by the volume of the ball with the same radius in the simply connected space form with constant curvature equal to K , which yields (198) with $C = 1$.

On the other hand, if $d_\partial(o) \leq r$, the ball hits ∂M . The condition $r \leq \text{inj}_\partial(M)/2$ implies that $B_o(r)$ lies in the region where d_∂ is smooth and $-H \leq \text{Hess}(d_\partial)$. Consider a length parametrized geodesic γ emanating from o , and directed towards the direction where d_∂ increases. In particular, letting $\cos \theta = g(\dot{\gamma}, \nabla d_\partial)$, it holds $\theta \in (-\pi/2, \pi/2)$ and

$$d_\partial(\gamma(t)) \geq -\frac{H}{2} \sin^2(\theta)t^2 + \cos(\theta)t + d_\partial(o), \quad \forall t \leq r. \quad (199)$$

Therefore, minimizing geodesics emanating from o and with length smaller than r do not cross ∂M provided that, e.g.,

$$\cos \theta \geq \frac{Hr}{2}. \quad (200)$$

Thanks to the assumption $r \leq 1/H$ the above inequality holds if $|\theta| < \pi/3$. Let $S_o(r) \subset B_o(r)$ be the corresponding spherical sector of radius r . By construction, o is its closest

point to ∂M . Since $r \leq r_0 \leq \text{inj}(M)$, we can fix normal polar coordinates $(s, \Omega) \in [0, r_0] \times \mathbb{S}^{n-1}$ at o . Therefore,

$$\text{vol}(B_o(r)) \geq \text{vol}(S_o(r)) = \int_{\bar{S}(r)} s^{n-1} A(s, \Omega) ds d\Omega, \quad (201)$$

where $\bar{S}(r)$ is the Euclidean spherical sector corresponding to $S_o(r)$ in these coordinates, and $s^{n-1} A(s, \Omega)$ is the Jacobian determinant of the exponential map with base o . By standard comparison arguments, the assumption $\text{Sec}(g) \leq K$ yields $A(s, \Omega) \geq A_K(s)$, where the latter is the corresponding object on the n -dimensional space form with constant curvature equal to K . Hence,

$$\text{vol}(S_o(r)) \geq \int_{\bar{S}(r)} s^{n-1} A_K(s) ds d\Omega. \quad (202)$$

Without loss of generality, we can fix coordinates $(\theta, \varphi) \in (-\pi/2, \pi/2) \times \mathbb{S}^{n-2}$ such that $\bar{S}(r) = \{|\theta| < \pi/3, s < r\}$. In these coordinates $d\Omega = \sin(\theta)^{n-2} d\theta d\varphi$, where $d\varphi$ is the standard measure on \mathbb{S}^{n-2} . Therefore,

$$\text{vol}(S_o(r)) \geq \int_0^r s^{n-1} A_K(s) ds \int_0^{\pi/3} \sin(\theta)^{n-2} \text{vol}(\mathbb{S}^{n-2}) d\theta = C \text{vol}(B_K(r)). \quad (203)$$

Simple symmetry considerations imply that $C \in (0, 1/2)$. \square

Lemma A.4 (Li-Yau inequality). *Let (M, g) be a complete n -dimensional Riemannian manifold with convex boundary, and $\text{Ric}(g) \geq -K(n-1)$, for some $K \geq 0$. Then there exist constants $C_1, C_2, C_3 > 0$, depending only on n , such that*

$$E^\pm(t, p, q) \leq \frac{C_1}{\sqrt{\text{vol}(B_p(\sqrt{t})) \text{vol}(B_q(\sqrt{t}))}} e^{C_2 K t - C_3 \frac{d^2(p, q)}{4t}}, \quad \forall (t, p, q) \in \mathbb{R}_+ \times M \times M. \quad (204)$$

Furthermore, let $H, K \geq 0$ be such that $|\text{Hess}(d_\partial)| \leq H$ for $d_\partial < \text{inj}_\partial(M)$, and $\text{Sec}(M) \leq K$, and let

$$\sqrt{t_0} = \min \left\{ \text{inj}(M), \frac{\text{inj}_\partial(M)}{2}, \frac{1}{H}, \frac{\pi}{\sqrt{K}} \right\}. \quad (205)$$

Then, there exists a constant $C_4 > 0$, depending only on n , such that

$$(4\pi t)^{n/2} E^\pm(t, p, q) \leq C_4 e^{-C_3 \frac{d^2(p, q)}{4t}}, \quad \forall (t, p, q) \in (0, t_0) \times M \times M. \quad (206)$$

Proof. The first inequality is the celebrated estimate [37, Thm. 3.2] by Li and Yau, where the parameters ε and α are fixed in the allowed ranges.

To prove the second part of the theorem, we uniformly bound from below the volumes appearing in the denominator of (204). Since $t < t_0$ we can apply both Lemma A.3 and A.2, and, in this range, $\text{vol}(B_K(\sqrt{t})) \geq C t^{n/2}$ for a constant $C > 0$ depending only on n . \square

The following theorem was suggested in [3, p. 69] for complete Riemannian structures with curvature bounded above and injectivity radius bounded below.

Lemma A.5. *Let (\mathbb{M}, g) be a Riemannian manifold, possibly non-complete. Let (N, h) be a closed submanifold with bounded second fundamental form $|II| \leq H$. Assume that, on*

a tube V_D around N of radius $D > 0$ at positive distance from the metric boundary of \mathbb{M} , we have $\text{Sec}(V_D, g) \leq K$ and $\text{inj}(V_D, g) \geq I$. Then it holds

$$\text{inj}(N, h) \geq \min \left\{ \frac{\pi}{\sqrt{K + H^2}}, \frac{\pi}{2\sqrt{K}}, I, D \right\}, \quad (207)$$

with the convention that $\pi/\sqrt{K} = \infty$ if $K \leq 0$.

Proof. By Gauss' equation, for all $X, Y, Z, W \in TN$, we have

$$R^g(X, Y, Z, W) = R^h(X, Y, Z, W) + II(X, Z)II(Y, W) - II(Y, Z)II(X, W). \quad (208)$$

It follows that $\text{Sec}(N, h) \leq K + H^2$. By Klingenberg's Lemma,

$$\text{inj}(N, h) \geq \min \left\{ \frac{\pi}{\sqrt{K + H^2}}, \frac{\ell(\gamma)}{2} \right\}, \quad (209)$$

where $\ell(\gamma)$ is length the shortest non-trivial closed geodesic in (N, h) . Let γ be such a geodesic, parametrized with unit speed. Its curvature in (\mathbb{M}, g) is bounded by

$$|\nabla_{\dot{\gamma}}^g \dot{\gamma}| = |II(\dot{\gamma}, \dot{\gamma})| \leq H. \quad (210)$$

Assume that $\ell(\gamma) < \min\{2I, \pi/\sqrt{K}, 2D\}$. In this case, γ lies in a ball B_R of (\mathbb{M}, g) with radius $R \leq \frac{\pi}{2\sqrt{K}}$ within the injectivity radius of its center, not touching the metric boundary of (\mathbb{M}, g) . Furthermore, the curvature on B_R is bounded above by K . By [12, p. 100] any two points in B_R have in B_R a unique minimizing geodesic of length $\leq 2R$ joining them. As a corollary of Rauch's Theorem [16, 1.30], geodesic triangles in B_R are thinner than corresponding model triangles in a standard space of constant curvature. Thus, B_R is a $\text{CAT}(K)$ space.⁴

The length of closed curves with geodesic curvature bounded from above in a $\text{CAT}(K)$ space can be bounded from below in terms of the length of the corresponding constant curvature circles on the 2-dimensional simply connected space form with constant curvature K , see [3, Cor. 1.2(c)]. We thus obtain that

$$\frac{\ell(\gamma)}{2} \geq \frac{\pi}{\sqrt{K + H^2}}. \quad (211)$$

We conclude easily, see also [4, Thm. 1.3]. \square

B Compactness of the resolvent

A non-complete Riemannian manifold (\mathbb{M}, g) has *regular metric boundary* if the distance δ from the metric boundary is smooth in a neighborhood $U = \{\delta < \varepsilon_0\}$ of the metric boundary (this is point (a) in Assumption **A**).

Proposition B.1 (Hardy inequality). *Let \mathbb{M} be a non-complete Riemannian manifold with regular metric boundary. Assume, moreover, that the boundaries $\partial\mathbb{M}_\varepsilon$ are mean convex for sufficiently small ε . Then, for sufficiently small ε , we have*

$$\int_{\mathbb{M}_0^\varepsilon} |\nabla u|^2 d\mu_g \geq \frac{1}{8} \int_{\mathbb{M}_0^\varepsilon} \frac{|u|^2}{\delta^2} d\mu_g, \quad \forall u \in H^1(\mathbb{M}_0^\varepsilon). \quad (212)$$

⁴We recall that a $\text{CAT}(K)$ space (also called an R_K domain) is a metric space in which any two points are joined by a unique minimizer and, for any triangle of minimizers of perimeter less than $2\pi/\sqrt{K}$, the distance between points on the triangle is at most equal to the distance between the corresponding points on the model triangle in the simply connected 2-dimensional space of curvature K .

Proof. Fix $\varepsilon > 0$ sufficiently small so that δ is smooth on \mathbb{M}_0^ε and $\Delta\delta = \text{Tr Hess } \delta \leq 0$. We start by considering $u \in C_c^\infty(\mathbb{M}_0^\varepsilon)$. Then, an integration by parts yields

$$0 \leq - \int_{\mathbb{M}_0^\varepsilon} |u|^2 \delta^{-1} \Delta\delta \, d\mu_g = - \int_{\mathbb{M}_0^\varepsilon} \frac{|u|^2}{\delta^2} \, d\mu_g + 2 \int_{\mathbb{M}_0^\varepsilon} \frac{u}{\delta} g(\nabla u, \nabla\delta) \, d\mu_g. \quad (213)$$

Here, we used the fact that $|\nabla\delta| \equiv 1$. By Cauchy-Schwarz inequality we then get

$$\int_{\mathbb{M}_0^\varepsilon} \frac{|u|^2}{\delta^2} \, d\mu_g \leq 2 \left(\int_{\mathbb{M}_0^\varepsilon} \frac{|u|^2}{\delta^2} \, d\mu_g \right)^{1/2} \left(\int_{\mathbb{M}_0^\varepsilon} |\nabla u|^2 \, d\mu_g \right)^{1/2}, \quad (214)$$

thus proving (212) with the bigger constant 1/4 for $u \in C_c^\infty(\mathbb{M}_0^\varepsilon)$. A straightforward density argument yields

$$\int_{\mathbb{M}_0^\varepsilon} |\nabla u|^2 \, d\mu_g \geq \frac{1}{4} \int_{\mathbb{M}_0^\varepsilon} \frac{|u|^2}{\delta^2} \, d\mu_g, \quad \forall u \in H_0^1(\mathbb{M}_0^\varepsilon). \quad (215)$$

Let now u be the restriction to \mathbb{M}_0^ε of a function in $C_c^\infty(\mathbb{M})$. Up to reducing ε , we have $\mathbb{M}_0^{2\varepsilon} = (x, z) \in (0, 2\varepsilon] \times Z$ for a fixed closed hypersurface Z , and there the metric reads $g = dx^2 + h(x)$, where $h(x)$ is a one-parameter family of Riemannian metrics on Z . Then, we let

$$\tilde{u}(x, z) := u(\min\{x, 2\varepsilon - x\}, z). \quad (216)$$

By construction, \tilde{u} is Lipschitz with compact support, smooth on \mathbb{M}_0^ε and $\mathbb{M}_\varepsilon^{2\varepsilon}$, and coincides with u on \mathbb{M}_0^ε . In particular, $\tilde{u} \in H_0^1(\mathbb{M}_0^{2\varepsilon})$ and thus, by the first part of the proof, we have

$$\int_{\mathbb{M}_0^{2\varepsilon}} |\nabla \tilde{u}|^2 \, d\mu_g \geq \frac{1}{4} \int_{\mathbb{M}_0^{2\varepsilon}} \frac{|\tilde{u}|^2}{\delta^2} \, d\mu_g. \quad (217)$$

Furthermore, $d\mu_g = e^{2\theta(x,z)} dx dz$ for some smooth reference measure dz on Z and smooth function $\theta : (0, 2\varepsilon] \times Z \rightarrow \mathbb{R}$. Thanks to the mean convexity assumption, $2\partial_x\theta = \text{Tr Hess } \delta \leq 0$ and, in particular, $\theta(x, z) \leq \theta(2\varepsilon - x, z)$ for all $x \in [\varepsilon, 2\varepsilon]$. As a consequence, we have

$$\int_{\mathbb{M}_\varepsilon^{2\varepsilon}} |\nabla \tilde{u}|^2 \, d\mu_g \leq \int_\varepsilon^{2\varepsilon} \int_Z |\nabla u(2\varepsilon - x, z)|^2 e^{2\theta(2\varepsilon - x, z)} \, dx dz = \int_{\mathbb{M}_0^\varepsilon} |\nabla u|^2 \, d\mu_g. \quad (218)$$

The above and (217) yield

$$\int_{\mathbb{M}_0^\varepsilon} |\nabla u|^2 \, d\mu_g \geq \frac{1}{2} \int_{\mathbb{M}_0^{2\varepsilon}} |\nabla \tilde{u}|^2 \, d\mu_g \geq \frac{1}{8} \int_{\mathbb{M}_0^{2\varepsilon}} \frac{|\tilde{u}|^2}{\delta^2} \, d\mu_g \geq \frac{1}{8} \int_{\mathbb{M}_0^\varepsilon} \frac{|u|^2}{\delta^2} \, d\mu_g, \quad (219)$$

for all $u \in C_c^\infty(\mathbb{M}) \cap C^\infty(\mathbb{M}_0^\varepsilon)$ and, by density, for all $u \in H^1(\mathbb{M}_0^\varepsilon)$. \square

The next proof follows the arguments of [47, Prop. 3.7]. The argument here is simplified thanks to the absence of an L_{loc}^2 potential.

Theorem B.2 (Compact embedding). *Let \mathbb{M} be a non-complete Riemannian manifold with compact metric completion and regular metric boundary. Assume, moreover, that the boundaries $\partial\mathbb{M}_\varepsilon$ are mean convex for sufficiently small ε . Then $H_0^1(\Omega)$ and $H^1(\Omega)$ compactly embed in $L^2(\Omega)$, where $\Omega = \mathbb{M}_a^b$ for $0 \leq a < b \leq \infty$.*

Proof. Although the only non-standard case is the case $a = 0$, we provide a unified proof for all a . Let $(u_n)_n \subset H_0^1(\Omega)$ be such that $\|u_n\|_{H^1(\Omega)} \leq C$ for some $C > 0$. In order to find a subsequence converging in $L^2(\Omega)$, we consider separately the behavior close and far away from the metric boundary. For a fixed $\varepsilon > 0$ sufficiently small, consider two Lipschitz functions $\phi_1, \phi_2 : \mathbb{M} \rightarrow [0, 1]$ such that $\phi_1 + \phi_2 \equiv 1$, $\phi_1 \equiv 1$ on $\mathbb{M}_0^{\varepsilon/2}$, $\text{supp } \phi_1 \subset \mathbb{M}_0^\varepsilon$, and $|\nabla \phi_i| \leq M$ for some $M > 0$. Define $u_{n,i} = \phi_i u_n$, so that, with a slight abuse of notation, $u_{n,1} \in H_0^1(\mathbb{M}_0^\varepsilon \cap \Omega)$ and $u_{n,2} \in H_0^1(\mathbb{M}_{\varepsilon/2}^\infty \cap \Omega)$.

By a density argument, a straightforward application of Leibniz rule, and Young inequality, for $i = 1, 2$ we have

$$\int_{\Omega} |\nabla u_{n,i}|^2 d\mu_g \leq 2 \int_{\Omega} (|\nabla \phi_i|^2 |u|^2 + \phi_i^2 |\nabla u|^2) d\mu_g. \quad (220)$$

By the fact that $\|u_n\|_{H^1(\Omega)} \leq C$ and that ϕ_i is uniformly Lipschitz, the above implies that, up to enlarging $C > 0$, it holds $\|u_{n,1}\|_{H^1(\mathbb{M}_0^\varepsilon \cap \Omega)} \leq C$ and $\|u_{n,2}\|_{H^1(\mathbb{M}_{\varepsilon/2}^\infty \cap \Omega)} \leq C$. Since $\mathbb{M}_{\varepsilon/2}^\infty \cap \Omega$ is relatively compact in (\mathbb{M}, g) , by [28, Cor. 10.21] we have that $H_0^1(\mathbb{M}_{\varepsilon/2}^\infty \cap \Omega)$ compactly embeds in $L^2(\mathbb{M}_{\varepsilon/2}^\infty \cap \Omega)$. Thus, $(u_{n,2})_n$, being bounded in $H_0^1(\mathbb{M}_{\varepsilon/2}^\infty \cap \Omega)$, admits a convergent subsequence in $L^2(\Omega)$.

On the other hand, by the Hardy inequality of Proposition B.1, we have

$$\|u_{n,1}\|_{L^2(\mathbb{M}_0^\varepsilon \cap \Omega)}^2 = \int_{\mathbb{M}_0^\varepsilon \cap \Omega} |u_{n,1}|^2 d\mu_g \leq 8\varepsilon^2 \int_{\mathbb{M}_0^\varepsilon \cap \Omega} |\nabla u_{n,1}|^2 d\mu_g \leq 8C\varepsilon^2, \quad (221)$$

where we used the boundedness of $(u_{n,1})_n$ in $H^1(\mathbb{M}_0^\varepsilon \cap \Omega)$. Then, by choosing $\varepsilon = \varepsilon_k = (\sqrt{8Ck})^{-1}$, we obtain that for any $k \in \mathbb{N}$ there exists a subsequence $n \mapsto \gamma_k(n)$ such that $u_{\gamma_k(n)} = u_{\gamma_k(n),1} + u_{\gamma_k(n),2}$ with $\|u_{\gamma_k(n),1}\| \leq 1/k$ and $(u_{\gamma_k(n),2})_n$ convergent in $L^2(\Omega)$. A diagonal argument yields the existence of a subsequence of $(u_n)_n$ convergent in $L^2(\Omega)$, proving the compact embedding of $H_0^1(\Omega)$ in $L^2(\Omega)$ (see e.g. [47, Prop. 3.7]).

To prove the analogous statement for $H^1(\Omega)$, we follow the same steps but, in this case, $u_{n,2} \in H^1(\mathbb{M}_{\varepsilon/2} \cap \Omega)$. Since $\mathbb{M}_{\varepsilon/2} \cap \Omega$ can be seen as a relatively compact subset with smooth boundary of a larger complete Riemannian manifold, $H^1(\mathbb{M}_{\varepsilon/2} \cap \Omega)$ compactly embeds in $L^2(\mathbb{M}_{\varepsilon/2}^\infty \cap \Omega)$.⁵ \square

Corollary B.3. *Let \mathbb{M} be a non-complete Riemannian manifold with compact metric completion and regular metric boundary. Assume, moreover, that the boundaries $\partial\mathbb{M}_\varepsilon^\infty$ are mean convex for sufficiently small ε . Then the resolvents $(\Delta_\Omega^\pm - z)^{-1}$ of the Dirichlet and Neumann Laplace-Beltrami operators are compact for any $z > 0$, where $\Omega = \mathbb{M}_a^b$ for $0 \leq a < b \leq \infty$. In particular, the spectra of Δ_Ω^\pm are discrete.*

Proof. By Theorem B.2, $H^1(\Omega)$ is compactly embedded in $L^2(\Omega)$. Since the domain $D(\Delta_\Omega^\pm)$ is contained in $H^1(\Omega)$, this implies the compactness of the resolvent. To this effect, and for completeness sake, we replicate the argument of [28, Thm. 10.20].

Since Δ_Ω^\pm is a non-positive operator, its resolvent set contains $(0, +\infty)$. Thus, for $z > 0$, $R_z := (\Delta_\Omega^\pm - z)^{-1}$ is a bounded self-adjoint operator in $L^2(\Omega)$. Moreover, for any $\psi \in L^2(\Omega)$ we have $u := R_z \psi \in D(\Delta_\Omega^\pm) \subset H^1(\Omega)$, whence

$$\int_{\Omega} |\nabla u|^2 d\mu_g + z \int_{\Omega} |u|^2 d\mu_g = - \int_{\Omega} \bar{u} (\Delta_\Omega^\pm u - zu) d\mu_g = - \int_{\Omega} \bar{u} \psi d\mu_g. \quad (222)$$

⁵This follows by the arguments of [28, Cor. 10.21, Second proof] and the Euclidean Rellich-Kondrachov Theorem [1, Thm. 6.3].

By the Cauchy-Schwarz inequality this implies

$$\min\{1, z\}\|u\|_{H^1}^2 \leq \|u\|_{L^2}\|\psi\|_{L^2} \leq \|u\|_{H^1}\|\psi\|_{L^2}. \quad (223)$$

We then get $\|R_z\psi\|_{H^1} \leq \max\{1, z^{-1}\}\|\psi\|_{L^2}$ for any $\psi \in L^2(\Omega)$. Since the embedding of $H^1(\Omega)$ in $L^2(\Omega)$ is compact, the operator $R_z : L^2(\Omega) \rightarrow L^2(\Omega)$ is compact. \square

References

- [1] R. A. Adams and J. J. F. Fournier. *Sobolev spaces*, volume 140 of *Pure and Applied Mathematics (Amsterdam)*. Elsevier/Academic Press, Amsterdam, second edition, 2003.
- [2] A. Agrachev, U. Boscain, and M. Sigalotti. A Gauss-Bonnet-like formula on two-dimensional almost-Riemannian manifolds. *Discrete Contin. Dyn. Syst.*, 20(4):801–822, 2008.
- [3] S. B. Alexander and R. L. Bishop. Comparison theorems for curves of bounded geodesic curvature in metric spaces of curvature bounded above. *Differential Geom. Appl.*, 6(1):67–86, 1996.
- [4] S. B. Alexander and R. L. Bishop. Gauss equation and injectivity radii for subspaces in spaces of curvature bounded above. *Geom. Dedicata*, 117:65–84, 2006.
- [5] L. Ambrosio, S. Honda, and D. Tewodrose. Short-time behavior of the heat kernel and Weyl’s law on $RCD^*(K, N)$ spaces. *Ann. Global Anal. Geom.*, 53(1):97–119, 2018.
- [6] A. L. Besse. *Einstein manifolds*. Classics in Mathematics. Springer-Verlag, Berlin, 2008. Reprint of the 1987 edition.
- [7] N. H. Bingham, C. M. Goldie, and J. L. Teugels. *Regular variation*, volume 27 of *Encyclopedia of Mathematics and its Applications*. Cambridge University Press, Cambridge, 1989.
- [8] P. Bolley, J. Camus, and P. T. Lai. Noyau, résolvante et valeurs propres d’une classe d’opérateurs elliptiques et dégénérés. In *Équations aux dérivées partielles (Proc. Conf., Saint-Jean-de-Monts, 1977)*, volume 660 of *Lecture Notes in Math.*, pages 33–46. Springer, Berlin, 1978.
- [9] U. Boscain and C. Laurent. The Laplace-Beltrami operator in almost-Riemannian geometry. *Ann. Inst. Fourier (Grenoble)*, 63(5):1739–1770, 2013.
- [10] U. Boscain, D. Prandi, and M. Seri. Spectral analysis and the Aharonov-Bohm effect on certain almost-Riemannian manifolds. *Comm. Partial Differential Equations*, 41(1):32–50, 2016.
- [11] P. Buser. A note on the isoperimetric constant. *Ann. Sci. École Norm. Sup. (4)*, 15(2):213–230, 1982.
- [12] P. Buser and H. Karcher. *Gromov’s almost flat manifolds*, volume 81 of *Astérisque*. Société Mathématique de France, Paris, 1981.
- [13] I. Chavel. *Eigenvalues in Riemannian geometry*, volume 115 of *Pure and Applied Mathematics*. Academic Press, Inc., Orlando, FL, 1984. Including a chapter by Burton Randol, With an appendix by Jozef Dodziuk.
- [14] J. Cheeger. On the Hodge theory of Riemannian pseudomanifolds. In *Geometry of the Laplace operator (Proc. Sympos. Pure Math., Univ. Hawaii, Honolulu, Hawaii, 1979)*, Proc. Sympos. Pure Math., XXXVI, pages 91–146. Amer. Math. Soc., Providence, R.I., 1980.
- [15] J. Cheeger. Spectral geometry of singular Riemannian spaces. *J. Differential Geom.*, 18(4):575–657 (1984), 1983.
- [16] J. Cheeger and D. G. Ebin. *Comparison theorems in Riemannian geometry*. AMS Chelsea Publishing, Providence, RI, 2008. Revised reprint of the 1975 original.

- [17] Y. Colin de Verdière. Ergodicité et fonctions propres du laplacien. *Comm. Math. Phys.*, 102(3):497–502, 1985.
- [18] Y. Colin de Verdière. L’asymptotique de Weyl pour les bouteilles magnétiques. *Comm. Math. Phys.*, 105(2):327–335, 1986.
- [19] Y. Colin de Verdière. Construction de laplaciens dont une partie finie du spectre est donnée. *Ann. Sci. École Norm. Sup. (4)*, 20(4):599–615, 1987.
- [20] Y. Colin de Verdière, L. Hillairet, and E. Trélat. Spectral asymptotics for sub-Riemannian Laplacians. II: microlocal Weyl measures. *Work in progress*.
- [21] Y. Colin de Verdière, L. Hillairet, and E. Trélat. Quantum ergodicity and quantum limits for sub-Riemannian Laplacians. In *Séminaire Laurent Schwartz—Équations aux dérivées partielles et applications. Année 2014–2015*, pages Exp. No. XX, 17. Ed. Éc. Polytech., Palaiseau, 2016.
- [22] Y. Colin de Verdière, L. Hillairet, and E. Trélat. Spectral asymptotics for sub-Riemannian Laplacians, I: Quantum ergodicity and quantum limits in the 3-dimensional contact case. *Duke Math. J.*, 167(1):109–174, 2018.
- [23] R. Courant and D. Hilbert. *Methods of mathematical physics. Vol. I*. Interscience Publishers, Inc., New York, N.Y., 1953.
- [24] A. L. M. Dekkers and L. de Haan. Optimal choice of sample fraction in extreme-value estimation. *J. Multivariate Anal.*, 47(2):173–195, 1993.
- [25] Y. Ding. Heat kernels and Green’s functions on limit spaces. *Comm. Anal. Geom.*, 10(3):475–514, 2002.
- [26] K. Fukaya. Collapsing of Riemannian manifolds and eigenvalues of Laplace operator. *Invent. Math.*, 87(3):517–547, 1987.
- [27] S. Golénia and S. Moroianu. The spectrum of Schrödinger operators and Hodge Laplacians on conformally cusp manifolds. *Trans. Amer. Math. Soc.*, 364(1):1–29, 2012.
- [28] A. Grigor’yan. *Heat kernel and analysis on manifolds*, volume 47 of *AMS/IP Studies in Advanced Mathematics*. American Mathematical Society, Providence, RI; International Press, Boston, MA, 2009.
- [29] A. Grigor’yan and L. Saloff-Coste. Heat kernel on manifolds with ends. *Ann. Inst. Fourier (Grenoble)*, 59(5):1917–1997, 2009.
- [30] A. Hassannezhad, G. Kokarev, and I. Polterovich. Eigenvalue inequalities on Riemannian manifolds with a lower Ricci curvature bound. *J. Spectr. Theory*, 6(4):807–835, 2016.
- [31] A. E. Ingham. On Tauberian theorems. *Proc. London Math. Soc. (3)*, 14a:157–173, 1965.
- [32] V. Ivrii. 100 years of Weyl’s law. *Bull. Math. Sci.*, 6(3):379–452, 2016.
- [33] V. Ivrii. *Microlocal Analysis, Sharp Spectral Asymptotics and Applications*, volume II of *Springer Monographs in Mathematics*. Springer International Publishing, 2019.
- [34] J. Karamata. Neuer Beweis und Verallgemeinerung einiger Tauberian-Sätze. *Math. Z.*, 33(1):294–299, 1931.
- [35] J. Korevaar. *Tauberian theory*, volume 329 of *Grundlehren der Mathematischen Wissenschaften [Fundamental Principles of Mathematical Sciences]*. Springer-Verlag, Berlin, 2004. A century of developments.
- [36] J. Lamperti. An occupation time theorem for a class of stochastic processes. *Trans. Amer. Math. Soc.*, 88:380–387, 1958.
- [37] P. Li and S.-T. Yau. On the parabolic kernel of the Schrödinger operator. *Acta Math.*, 156(3-4):153–201, 1986.

- [38] M. Lianantonakis. On the eigenvalue counting function for weighted Laplace-Beltrami operators. *J. Geom. Anal.*, 10(2):299–322, 2000.
- [39] H. P. McKean, Jr. and I. M. Singer. Curvature and the eigenvalues of the Laplacian. *J. Differential Geometry*, 1(1):43–69, 1967.
- [40] A. Menikoff and J. Sjöstrand. On the eigenvalues of a class of hypoelliptic operators. II. In *Global analysis (Proc. Biennial Sem. Canad. Math. Congr., Univ. Calgary, Calgary, Alta., 1978)*, volume 755 of *Lecture Notes in Math.*, pages 201–247. Springer, Berlin, 1979.
- [41] A. Morame and F. Truc. Magnetic bottles on the Poincaré half-plane: spectral asymptotics. *J. Math. Kyoto Univ.*, 48(3):597–616, 2008.
- [42] A. Morame and F. Truc. Magnetic bottles on geometrically finite hyperbolic surfaces. *J. Geom. Phys.*, 59(7):1079–1085, 2009.
- [43] G. Nenciu and I. Nenciu. On confining potentials and essential self-adjointness for Schrödinger operators on bounded domains in \mathbb{R}^n . *Ann. Henri Poincaré*, 10(2):377–394, 2009.
- [44] G. Perelman. Construction of manifolds of positive Ricci curvature with big volume and large Betti numbers. In *Comparison geometry (Berkeley, CA, 1993–94)*, volume 30 of *Math. Sci. Res. Inst. Publ.*, pages 157–163. Cambridge Univ. Press, Cambridge, 1997.
- [45] K. Petersen. *Ergodic theory*, volume 2 of *Cambridge Studies in Advanced Mathematics*. Cambridge University Press, Cambridge, 1983.
- [46] P. Petersen. *Riemannian geometry*, volume 171 of *Graduate Texts in Mathematics*. Springer, Cham, third edition, 2016.
- [47] D. Prandi, L. Rizzi, and M. Seri. Quantum confinement on non-complete Riemannian manifolds. *J. Spectr. Theory*, 8(4):1221–1280, 2018.
- [48] S. Rosenberg. *The Laplacian on a Riemannian manifold*, volume 31 of *London Mathematical Society Student Texts*. Cambridge University Press, Cambridge, 1997. An introduction to analysis on manifolds.
- [49] M. A. Shubin. *Pseudodifferential operators and spectral theory*. Springer-Verlag, Berlin, second edition, 2001. Translated from the 1978 Russian original by Stig I. Andersson.
- [50] J. Sjöstrand. On the eigenvalues of a class of hypoelliptic operators. IV. *Ann. Inst. Fourier (Grenoble)*, 30(2):vi, 109–169, 1980.
- [51] A. Suleymanova. Heat trace expansion on manifolds with conic singularities. *ArXiv e-prints*, Jan. 2017.
- [52] A. Suleymanova. On the spectral geometry of manifolds with conic singularities. *ArXiv e-prints*, Oct. 2017.
- [53] J. Wong. An extension procedure for manifolds with boundary. *Pacific J. Math.*, 235(1):173–199, 2008.
- [54] H.-C. Zhang and X.-P. Zhu. Weyl’s law on $RCD^*(K, N)$ metric measure spaces. *Comm. Anal. Geom.* (in press), Jan. 2017.