



HAL
open science

Weyl's law for singular Riemannian manifolds

Yacine Chitour, Dario Prandi, Luca Rizzi

► **To cite this version:**

Yacine Chitour, Dario Prandi, Luca Rizzi. Weyl's law for singular Riemannian manifolds. 2019. hal-01902740v2

HAL Id: hal-01902740

<https://hal.science/hal-01902740v2>

Preprint submitted on 5 Feb 2019 (v2), last revised 18 Aug 2023 (v5)

HAL is a multi-disciplinary open access archive for the deposit and dissemination of scientific research documents, whether they are published or not. The documents may come from teaching and research institutions in France or abroad, or from public or private research centers.

L'archive ouverte pluridisciplinaire **HAL**, est destinée au dépôt et à la diffusion de documents scientifiques de niveau recherche, publiés ou non, émanant des établissements d'enseignement et de recherche français ou étrangers, des laboratoires publics ou privés.

Weyl's law for singular Riemannian manifolds

Y. Chitour*, D. Prandi†, L. Rizzi‡

February 5, 2019

Abstract

We study the asymptotic growth of the eigenvalues of the Laplace-Beltrami operator on singular Riemannian manifolds, where all geometrical invariants appearing in classical spectral asymptotics are unbounded, and the total volume can be infinite. Under suitable assumptions on the curvature blow-up, we prove how the presence of the singularity influences the Weyl's asymptotics and the localization of the eigenfunctions for large frequencies.

As a consequence of our results we identify a class of singular structures such that the corresponding Laplace-Beltrami operator has the following non-classical Weyl's law:

$$N(\lambda) \sim \frac{\omega_n}{(2\pi)^n} \lambda^{n/2} v(\lambda),$$

where v is slowly varying at infinity in the sense of Karamata. Finally, for any non-decreasing slowly varying function v , we construct a singular Riemannian structure prescribing the above Weyl's law.

A key tool in the proof is a universal estimate for the remainder of the heat trace on Riemannian manifolds, which is of independent interest.

Contents

1	Introduction	2
1.1	The Grushin sphere model	2
1.2	Assumptions and main results	3
1.3	Structure of the proof	5
1.4	Other classes of singular structures	6
2	Heat kernel estimates with remainder	8
2.1	Notation and preliminaries	8
2.2	On-diagonal heat kernel estimates	9
2.3	Heat trace bound	12
2.4	Weyl's law with remainder	15

*Laboratoire des Signaux et Systèmes, Université Paris-Sud, CentraleSupélec, Gif-sur-Yvette

†CNRS, Laboratoire des Signaux et Systèmes, CentraleSupélec, Gif-sur-Yvette

‡Univ. Grenoble Alpes, CNRS, Institut Fourier, F-38000 Grenoble, France

3	Geometric structure at the singularity	17
4	Weyl's asymptotics for singular manifolds	19
5	Exact Weyl's law for slowly varying volume	22
5.1	Metrics with prescribed Weyl's law	26
6	Concentration of eigenfunctions	28
7	Strongly regular ARS	30
7.1	Curvature bounds	31
7.2	Weyl asymptotics for ARS	33
A	Auxiliary geometric estimates	34
B	Compactness of the resolvent	37

1 Introduction

In [44], Hermann Weyl studied the distribution of eigenvalues for the Laplace operator on bounded domains of \mathbb{R}^n , and proved the following asymptotic formula:

$$N(\lambda) \sim \frac{\omega_n}{(2\pi)^n} \text{vol}(\Omega) \lambda^{n/2} \quad \lambda \rightarrow \infty. \quad (1)$$

Here, $N(\lambda)$ is the number of eigenvalues smaller than λ for the Dirichlet Laplacian on a bounded domain $\Omega \subset \mathbb{R}^n$ (also called the eigenvalue counting or Weyl's function), and $\text{vol}(\Omega)$ is its Lebesgue measure. The classical proof of this result employs the variational method known as Dirichlet-Neumann bracketing, and the explicit estimate with remainder of the eigenvalue counting function on cubes, see e.g. [19].

Weyl's law has been proved to hold for the Laplace-Beltrami operator on compact Riemannian manifolds, where the Lebesgue measure is replaced by the Riemannian one. In this case (1) is a consequence of the celebrated Minakshisundaram-Pleijel heat kernel asymptotics and the Karamata tauberian theorem, see e.g. [10].

As we will see shortly, the finiteness of the volume is not necessary for the discreteness of the spectrum of the Laplace-Beltrami operator. Since in the case of infinite volume the r.h.s. of (1) is infinite, one might wonder what the leading order of $N(\lambda)$ is, as $\lambda \rightarrow \infty$, and which spectral invariant it encodes.

A well understood example is that of quasi-bounded domains of \mathbb{R}^2 , as the horn-shaped domains $\{(x, y) \mid |x|^\alpha |y| \leq 1\}$. It turns out that the parameter α is a spectral invariant appearing in the leading order of $N(\lambda)$, which is of the form $\lambda \log \lambda$ for $\alpha = 1$, and $\lambda^{(1+\alpha)/2}$ otherwise, see [40, 43] and references therein for details. In these cases the difficulty in the study of the Weyl function arises from the unboundedness of the domain, since the intrinsic geometry of the problem is trivial.

1.1 The Grushin sphere model

In this paper we are concerned with singular Riemannian structures, where all geometric invariants, including the curvature and the volume, can be unbounded. We

first discuss a simple model representing the class of singularities under investigation. This is an almost-Riemannian structure in the sense of [2, 8].

Consider the two dimensional sphere $\mathbb{S}^2 \subset \mathbb{R}^3$. Let X and Y be the generators of rotations around the x and y axis, respectively. These vector fields are collinear on the equator $\mathcal{Z} = \{(x, y, z) \in \mathbb{S}^2 \mid z = 0\}$, and linearly independent elsewhere. By declaring X, Y to be orthonormal, we define a Riemannian structure on the sphere, which is singular on \mathcal{Z} (the coefficients of the metric explode). Nevertheless, the associated Laplace-Beltrami operator, with domain $C_c^\infty(N \setminus \mathcal{Z})$ is essentially self-adjoint on $L^2(N \setminus \mathcal{Z}, d\mu_g)$ and has discrete spectrum [8]. Due to the high symmetry of the problem the spectrum can be explicitly computed, and in [7] the following non-classical asymptotics has been obtained:

$$N(\lambda) \sim \frac{1}{4} \lambda \log \lambda, \quad \lambda \rightarrow \infty. \quad (2)$$

It is easy to check that the total Riemannian volume of $N \setminus \mathcal{Z}$ is infinite, and the curvature explodes to $-\infty$ at the equator¹. Hence, heat kernel and heat trace estimates are bound to blow up close to the singular region, and it is not clear how to deduce the asymptotic behaviour of $N(\lambda)$ using tauberian techniques.

1.2 Assumptions and main results

Let (\mathcal{M}, g) be a non-complete Riemannian manifold. The singular set must be thought as a subset of the metric boundary approaching whom all geometric quantities such as the curvature, the measure of balls, et cetera, blow up. Such a blow up must occur in a controlled fashion.

Assumption (Σ). There exists a neighborhood $U = \{\delta < \varepsilon_0\}$ of the metric boundary such that the following hold:

- (a) Regularity: the distance δ from the metric boundary is smooth;
- (b) Convexity: the level sets of δ are convex, that is $\text{Hess}(\delta) \leq 0$;
- (c) Curvature control: there exists $C > 0$ such that $|\text{Sec}| \leq C\delta^{-2}$;
- (d) Injectivity radius control: there exists $C > 0$ such that $\text{inj} \geq C\delta$.

The above assumption implies that we can approach the singularity through an exhaustion $\mathcal{M}_\varepsilon = \{\delta \geq \varepsilon\}$ of smooth Riemannian manifold with convex boundary, with curvature explosion at most quadratic and injectivity radius going to zero at most linearly as $\varepsilon \rightarrow 0$.

Remark 1.1. The injectivity radius control in the assumption (Σ) is automatically satisfied if the level sets of δ are strictly convex, see Proposition 3.2.

¹This is the case for all 2-dimensional ARS. However, let us point out that for $n > 2$ one can build similar structures where the curvature is unbounded both above and below, see Example 7.1.

We consider the Friedrichs extension Δ of the Laplace-Beltrami operator with domain $C_c^\infty(\mathcal{M})$, that is the unique self-adjoint operator in $L^2(\mathcal{M}, d\mu_g)$ associated with the quadratic form

$$Q(u) = \int_M |\nabla u|^2 d\mu_g, \quad \forall u \in C_c^\infty(\mathcal{M}). \quad (3)$$

Our first result is the following.

Theorem 1.1. *Let \mathcal{M} be a Riemannian manifold satisfying Assumption (Σ) and with compact metric completion. Then there exists $C_\pm > 0$ and $\Lambda > 0$ such that*

$$C_- \leq \frac{N(\lambda)}{\lambda^{n/2} \text{vol}(\mathcal{M}_{1/\sqrt{\lambda}})} \leq C_+, \quad \forall \lambda \geq \Lambda. \quad (4)$$

Remark 1.2. The convexity assumption is used to prove the compactness of the resolvent of Δ and it plays a fundamental role in several comparison estimates of the remainder of the Weyl's asymptotics for the truncations.

In the general setting of Theorem 1.1, we are not able to obtain a precise asymptotic for $N(\lambda)$ as $\lambda \rightarrow \infty$. In fact, this result only yields a leading order for the latter, and does not even imply the existence of a limit in (4). In order to obtain the precise Weyl asymptotic, we need more precise assumptions on the volume growth, as measured by the quantity

$$v(\lambda) := \text{vol}(\mathcal{M}_{1/\sqrt{\lambda}}). \quad (5)$$

Recall that v is slowly varying at infinity in the sense of Karamata if $v(a\lambda) \sim v(\lambda)$ as $\lambda \rightarrow \infty$ for all positive a . Some examples of slowly varying functions are $\log \lambda$, the iterates $\log_k \lambda = \log_{k-1} \log \lambda$, rational functions with positive coefficients formed with the $\log_k \lambda$. The following result is proved in Section 5.

Theorem 1.2. *Let \mathcal{M} be a Riemannian manifold satisfying Assumption (Σ) and with compact metric completion. Then, if v is slowly varying, we have*

$$\lim_{\lambda \rightarrow \infty} \frac{N(\lambda)}{\lambda^{n/2} v(\lambda)} = \frac{\omega_n}{(2\pi)^n}. \quad (6)$$

Here, ω_n is the volume of the n -dimensional Euclidean unit ball.

Remark 1.3. The assumptions of Theorem 1.2 are verified for the Grushin structure of Section 1.1. More generally, they are verified for generic 2-dimensional ARS without tangency points, see Section 7. In these cases $v(\lambda) = \sigma \log \lambda$ for some $\sigma > 0$ depending on the structure.

A celebrated result due to Y. Colin de Verdière states that, for any finite sequence of m positive integer numbers, one can find a compact Riemannian manifold M such that these numbers are the first m eigenvalues of M , see [15]. Exploiting Theorem 1.2, we prove a counterpart at infinity of this result, prescribing the large eigenvalues asymptotic in place of a finite part of the spectrum (see Section 5).

Theorem 1.3. *For any compact manifold N of dimension n and non-decreasing slowly varying function $v : \mathbb{R}_+ \rightarrow \mathbb{R}_+$ there exists a Riemannian structure on N , singular along any prescribed submanifold S , such that for its Laplace-Beltrami operator the Weyl's law (6) holds.*

Observe that the Laplace-Beltrami operator associated with the structure given by Theorem 1.3 is essentially self-adjoint, see Remark 5.1.

Via a classical argument, we also prove the concentration of eigenfunctions of the Laplace-Beltrami operator at the metric boundary, in presence of a non-classical Weyl's asymptotic. A precise statement is the following (see Sec. 6).

Theorem 1.4. *Let \mathcal{M} be a n -dimensional non-complete Riemannian manifold such that the Laplace-Beltrami operator Δ has discrete spectrum, and*

$$\lim_{\lambda \rightarrow \infty} \frac{N(\lambda)}{\lambda^{n/2}} = \infty, \quad (7)$$

Let $0 \leq \lambda_1 \leq \lambda_2 \leq \dots$ be the eigenvalues of $-\Delta$, and, for all $i \in \mathbb{N}$, denote by ϕ_i a normalized eigenfunction associated with the eigenvalue λ_i . Then, there exists a density one subset $S \subseteq \mathbb{N}$ such that for any compact U it holds

$$\lim_{\substack{i \rightarrow \infty \\ i \in S}} \int_U |\phi_i(x)|^2 d\mu_g(x) = 0. \quad (8)$$

In particular Theorem 1.4 applies to all structures satisfying the assumptions of Theorem 1.1, provided that the volume of \mathcal{M} is infinite.

Finally, in Section 7, we apply our results to a class of almost-Riemannian structures, which generalize the Grushin sphere model discussed above.

1.3 Structure of the proof

We sketch the proof of Theorem 1.1, which is carried out in detail in Section 4, and present a key technical tool occurring in the proof. The argument relies on a combination of variational and tauberian techniques. In its simplest instance, we split $\mathcal{M} = \mathcal{M}_0^\varepsilon \cup \mathcal{M}_\varepsilon^\infty$. By Dirichlet-Neumann bracketing, we bound $N(\lambda)$ with the sum of the counting functions for the Laplace-Beltrami operator on the two domains, with Neumann (+) or Dirichlet (-) boundary conditions, respectively:

$$N_{[0,\varepsilon]}^-(\lambda) + N_{[\varepsilon,\infty]}^-(\lambda) \leq N(\lambda) \leq N_{[0,\varepsilon]}^+(\lambda) + N_{[\varepsilon,\infty]}^+(\lambda). \quad (9)$$

Formula (9), as $\varepsilon \rightarrow 0$, should determine the asymptotics of $N(\lambda)$ as $\lambda \rightarrow \infty$.

The implementation of this simple strategy is quite delicate. Thanks to the convexity assumption, $\mathcal{M}_0^\varepsilon$ supports a Hardy-type inequality. As a consequence, $N_{[0,\varepsilon(\lambda)]}^\pm(\lambda) = 0$, provided that $\varepsilon \rightarrow 0$ sufficiently fast (in a quantitative way) as $\lambda \rightarrow \infty$. In this regime the asymptotics of $N(\lambda)$ is controlled by the Weyl function of the truncation $\mathcal{M}_{\varepsilon(\lambda)}^\infty$. The latter is a Riemannian manifold with boundary and finite volume, which satisfies indeed the classical Weyl's law

$$N_{[\varepsilon(\lambda),\infty]}^\pm(\lambda) \sim \frac{\omega_n}{(2\pi)^n} \text{vol}(\mathcal{M}_{\varepsilon(\lambda)}^\infty) \lambda^{n/2}. \quad (10)$$

The implicit remainder in (10), which depends on the parameter of the truncation $\varepsilon(\lambda)$, must be carefully controlled as $\lambda \rightarrow \infty$. The key tool here is the following heat-trace asymptotic formula with universal remainder², proved in Section 2.

Theorem 1.5 (Heat trace asymptotics with quantitative remainder). *Let (M, g) be a smooth compact n -dimensional Riemannian manifold with convex boundary ∂M . Let $K, H \geq 0$ such that $|\text{Sec}(M)| \leq K$ and $|\text{Hess}(\delta)| \leq H$ for $d_\partial < \text{inj}_{\partial M}$. Then there exists a constant $c > 0$, depending only on n , such that the following estimate for the Dirichlet and Neumann heat kernels holds:*

$$\left| \frac{(4\pi t)^{n/2}}{\text{vol}(M)} \int_M p^\pm(t, x, x) d\mu_g(x) - 1 \right| \leq c \left(\frac{t}{t_0} \right)^{1/2}, \quad (11)$$

for all values of $t \in \mathbb{R}_+$ such that

$$\sqrt{t} \leq \sqrt{t_0} = \min \left\{ \text{inj}_M, \frac{\text{inj}_{\partial M}}{2}, \frac{\pi}{\sqrt{K}}, \frac{1}{H} \right\}. \quad (12)$$

As a consequence of Theorem 1.5, and a suitable Karamata-type theorem with remainder (due to Ingham [26]), we obtain an asymptotic formula with universal remainder for the eigenvalue counting function of the Laplace-Beltrami operator on a compact Riemannian manifold with boundary as $\lambda \rightarrow \infty$ (see Theorem 2.5). The latter also implies a Buser’s inequality for manifolds with convex boundaries similar to the one proved in [25] with different techniques (see Corollary 2.6).

When applied to the truncations $M = \mathcal{M}_{\varepsilon(\lambda)}^\infty$, this result singles out the quantities whose explosion must be controlled as $\lambda \rightarrow \infty$ and $\varepsilon \rightarrow 0$, concluding the proof.

1.4 Other classes of singular structures

Conical singularity. There is a sharp difference between our class of singular structures and conical singularities [11]. In this latter case, our techniques do not apply since the boundaries of the truncations $\mathcal{M}_\varepsilon^\infty$ are concave (hence non-convex) as $\varepsilon \rightarrow 0$. However, the spectrum of the Laplace-Beltrami is still discrete, the total volume is finite, and the classical Weyl’s law (1) holds. In this sense, conical singularities are more gentle, and do not modify the leading order of the Weyl function with respect to the non-singular compact case. Indeed, conical singularities are detected only at much higher order, see [41, 42].

Structures with locally bounded geometry In [30] the author considers non-complete Riemannian structures (\mathcal{M}, g) , equipped with a weighted measure $\sigma^2 d\mu_g$, and the unique self-adjoint operator in $L^2(\mathcal{M}, \sigma^2 d\mu_g)$, associated with the Friedrichs extension of the quadratic form

$$Q(u) = \int_{\mathcal{M}} |\nabla u|^2 \sigma^2 d\mu_g, \quad u \in C_c^\infty(\mathcal{M}). \quad (13)$$

²By “universal remainder”, we mean that it depends only on a handful of geometrical intrinsic quantities, and fixed dimensional constants.

The Riemannian measure $d\mu_g$ and the weight σ might be singular at the metric boundary, and no regularity of the metric boundary is assumed. The author derives in this setting Weyl's asymptotics similar to the ones of Theorem 1.1. Despite the similarities, the setting and methods of [30] are rather different with respect to ours. The assumptions in [30] imply that \mathcal{M} is locally uniformly bi-Lipschitz equivalent to an Euclidean ball. If the metric completion is compact, this implies that the Riemannian measure of \mathcal{M} is finite. In particular [30] cannot be applied to the simplest model of our class of singularities, that is the Grushin sphere.

ARS with smooth measures. An analogue to Theorem 1.2 for 2-dimensional ARS was announced in [17], as a consequence of a more general local Weyl's law for sub-Laplacians [18, 16]. There, the authors are concerned with the Friedrichs extension associated with the quadratic form

$$Q(u) = \int_N |\nabla u|^2 d\omega, \quad u \in C^\infty(N), \quad (14)$$

where N is a smooth compact manifold carrying a smooth almost-Riemannian structure (the reader not familiar with AR geometry can think at the example of the Grushin sphere discussed above, where $N = \mathbb{S}^2$). The norm of the gradient is well defined and smooth everywhere, including at the singular region $\mathcal{Z} \subset N$ and the measure $d\omega$ is positive and smooth on N . Even if the Weyl's asymptotics is known to be invariant when replacing ω by $e^\phi \omega$, for $\phi \in C^\infty(N)$, it is not clear how the spectral asymptotics are related when ϕ explodes at \mathcal{Z} . It is actually surprising that, for generic 2-ARS, we obtain the same Weyl's law in our setting, where $d\omega = d\mu_g$ is singular on \mathcal{Z} , and the domain of the form (14) is $C_c^\infty(N \setminus \mathcal{Z})$.

Magnetic bottles. It would be interesting to extend our results to the magnetic Laplacian, that is the self-adjoint operator $-\Delta_A$ associated with the quadratic form

$$Q_A(u) = \int_{\mathcal{M}} |du - iuA|^2 d\mu_g, \quad u \in C_c^\infty(\mathcal{M}), \quad (15)$$

where \mathcal{M} is a Riemannian manifold, A is a one-form representing the magnetic potential, and $|\cdot|$ here is the dual Riemannian norm on the complexified cotangent bundle. The two-form $B = dA$ is the magnetic field. When $-\Delta_A$ has compact resolvent and is essentially self-adjoint on $C_c^\infty(\mathcal{M})$, one talks about *magnetic bottles*. The Weyl's law for magnetic bottles on \mathbb{R}^n has been studied in [14], for the Poincaré half-plane in [32], and more generally for geometrically finite hyperbolic surfaces in [33]. In all these cases, the results are proved through the variational method and localization on suitable small cubes. To our knowledge, the problem on manifolds with non-constant and possibly exploding curvature has not been yet addressed.

Metric measure spaces. Recently, in [4, 46], the authors studied the pointwise convergence of heat kernels for sequences of infinitesimally Hilbertian metric measure spaces with Ricci curvature bounded from below, the so-called RCD-spaces. This class includes all measured-Gromov-Hausdorff limits of complete Riemannian structures with Ricci curvature uniformly bounded from below, and dimension uniformly bounded from above. As a consequence, the authors also prove that any

RCD-space satisfies a classical Weyl’s law. Therefore, our contribution can be seen as the first step toward the investigation of the Weyl’s asymptotics for limits of Riemannian structures (X_n, g_n, μ_{g_n}) where the Ricci curvature is *unbounded*.

Acknowledgments

This work was supported by the Grant ANR-15-CE40-0018 of the ANR, and by a public grant as part of the Investissement d’avenir project, reference ANR-11-LABX-0056-LMH, LabEx LMH, in a joint call with the “FMJH Program Gaspard Monge in optimization and operation research”. This work has been supported by the ANR project ANR-15-IDEX-02 and by a public grant overseen by the French National Research Agency (ANR) as part of the Investissement d’avenir program, through the iCODE project funded by the IDEX Paris-Saclay, ANR-11-IDEX-0003-02.

We wish to thank R. Neel, and S. Gallot for stimulating discussions, and also Y. Colin de Verdière for his helpful suggestions that, in particular, led to Section 6. We also warmly thank L. de Haan for pointing out a key technical result due to A. A. Balkema about de Haan functions contained in [20, Appendix B].

2 Heat kernel estimates with remainder

Let (M, g) be a smooth n -dimensional Riemannian manifold, with smooth boundary ∂M . In this section we prove on-diagonal estimates for the heat kernel and the heat trace of M , with an explicit control on the remainder term.

2.1 Notation and preliminaries

The injectivity radius at $x \in M$, denoted by $\text{inj}_M(x)$, is the supremum of times $t > 0$ such that every unit-speed geodesic emanating from x and defined up to time t is length-minimizing. The *injectivity radius of M* is then equal to

$$\text{inj}_M = \inf_{x \in M} \text{inj}_M(x). \quad (16)$$

This definition extends the classical one for possibly non-complete Riemannian manifolds with boundary. Observe that the exponential map $\exp_x : T_x M \rightarrow M$ is a diffeomorphism when restricted to the largest ball of radius smaller than $\text{inj}(x)$ contained in the domain of the exponential map (geodesics may cease to be defined when they hit the boundary or the metric boundary of the manifold).

We denote the Riemannian distance from ∂M by $d_\partial : M \rightarrow [0, +\infty)$, that is

$$d_\partial(x) = \inf_{z \in \partial M} d(x, z). \quad (17)$$

A length-parametrized geodesic $\gamma : [0, t] \rightarrow M$, $\gamma(0) \in \partial M$ is length-minimizing w.r.t. the boundary if for all $0 \leq s < t$ it holds $d_\partial(\gamma(s)) = s$. In particular, it necessarily holds that $\dot{\gamma}(0) \perp T_{\gamma(0)}\partial M$ and that $\gamma(0)$ is the only point of ∂M realising $d_\partial(\gamma(s))$. The *injectivity radius from ∂M* , denoted by $\text{inj}_{\partial M}$, is then defined as inj_M , by replacing length-minimizing geodesics with length-minimizing geodesics w.r.t. the boundary.

For a smooth function $f : M \rightarrow \mathbb{R}$, we let

$$\text{Hess}(f)(X, Y) = g(\nabla_X \nabla f, Y), \quad X, Y \in \Gamma(M), \quad (18)$$

where ∇ denotes the covariant derivative. The notation $\text{Hess}(f) \geq c$ (resp. $\leq c$) for some constant $c \in \mathbb{R}$ is to be understood in the sense of quadratic forms and w.r.t. the metric g . The boundary ∂M is convex (resp. strictly convex) if its second fundamental form $\text{Hess}(d_\partial)|_{\partial M}$ is non-positive (resp. negative). Moreover, it is mean convex if $\text{Tr Hess}(d_\partial)|_{\partial M} \leq 0$.

2.2 On-diagonal heat kernel estimates

The Dirichlet and Neumann heat kernels p^+ and p^- are the minimal fundamental solutions of the heat equation associated with the Laplace-Beltrami operator $\Delta = \text{div} \circ \nabla$ with, respectively, Dirichlet or Neumann boundary conditions. We denote the corresponding operators by Δ^+ and Δ^- .

The main theorem of the section is the following.

Theorem 2.1. *Let (M, g) be a smooth compact n -dimensional Riemannian manifold with convex boundary ∂M . Let $K \geq 0$ be such that $|\text{Sec}(M)| \leq K$. Moreover, let*

$$\rho(x) = \min \left\{ \frac{d_\partial(x)}{2}, \text{inj}_M \right\}, \quad \forall x \in M. \quad (19)$$

Then there exist positive constants $c_1, c_2, c_3 > 0$, depending only on n , such that

$$\left| (4\pi t)^{n/2} p^\pm(t, x, x) - 1 \right| \leq c_1 K t + c_2 e^{-c_3 \frac{\rho(x)^2}{4t}}, \quad \forall \sqrt{t} \leq \min \left\{ \rho(x), \frac{\pi}{\sqrt{K}} \right\}. \quad (20)$$

Proof. Consider the double $\bar{M} = M \cup_{\partial M} M$ of M , which is a compact smooth manifold without boundary, endowed with the Lipschitz metric \bar{g} inherited from g . Let \bar{d} and $\bar{\mu}$ denote the corresponding metric and measure on \bar{M} . Clearly, \bar{d} and $\bar{\mu}$ coincide with d and μ , when restricted to either isometric copy $M \subset \bar{M}$. Following [31], although the coefficients of the Laplace-Beltrami operator are discontinuous there is a well-defined heat kernel \bar{p} on (\bar{M}, \bar{g}) , which satisfies

$$p^\pm(t, x, y) = \bar{p}(t, x, y) \mp \bar{p}(t, x, y^*), \quad \forall x, y \in M, \quad (21)$$

where $y^* \in \bar{M}$ denotes the reflection of y w.r.t. the boundary $\partial M \in \bar{M}$. We organize the proof in several steps.

Step 1. Gromov-Hausdorff approximation. For $\tau > 0$, there exists a sequence \bar{g}_τ of smooth Riemannian metrics on \bar{M} such that

- $(M, \bar{d}_\tau, \bar{\mu}_\tau) \rightarrow (\bar{M}, \bar{d}, \bar{\mu})$ in the measured Gromov-Hausdorff sense, as $\tau \rightarrow 0$;
- $\text{Ric}(\bar{g}_\tau) \geq -K(n-1)$, for all values of τ ;
- for any compact set K such that $K \cap \partial M = \emptyset$ and for sufficiently small τ , we have $\bar{g}_\tau|_K = \bar{g}|_K$;

- the distance to ∂M in \bar{M} w.r.t. \bar{g}_τ coincides with d_∂ , seen as a function on \bar{M} .

The construction of this family is sketched in [35, Sec. 4] for positive Ricci curvature and strictly convex boundary. It is not hard to check that this extends to the case of convex boundary, see [45, Thm. 1.8] and references therein for details. The measured Gromov-Hausdorff convergence in the sense of Fukaya [22] follows from the fact that, in this construction, $\bar{g}_\tau \rightarrow \bar{g}$ uniformly in coordinates.

As a consequence of the measured Gromov-Hausdorff convergence and the Ricci bound, we have the convergence of the corresponding heat kernels $\bar{p}^\tau : \mathbb{R}_+ \times \bar{M} \times \bar{M}$

$$\lim_{\tau \downarrow 0} \bar{p}^\tau(t, x, y) = \bar{p}(t, x, y), \quad \forall (t, x, y) \in \mathbb{R}_+ \times \bar{M} \times \bar{M}, \quad (22)$$

uniformly on $\bar{M} \times \bar{M}$, for any fixed t . See [21, Theorem 2.6].

The argument consists in obtaining lower and upper bounds for \bar{p}^τ that are uniform w.r.t. τ . Passing to the limit and using (21) will then yield the statement.

Step 2. Lower bound. The lower bound on \bar{p}^τ is a consequence of classical comparison theorems for the heat kernel with Ricci lower bounds on complete manifolds without boundary. Indeed, applying [10, Thm. 7, p. 196] we have $p_{-K}(t, d(x, y)) \leq \bar{p}^\tau(t, x, y)$ for all $(t, x, y) \in \mathbb{R}_+ \times \bar{M} \times \bar{M}$, for all $n \in \mathbb{N}$, and where $p_{-K} : \mathbb{R}_+ \times [0, +\infty) \rightarrow \mathbb{R}$ is the heat kernel for the simply connected space form of constant curvature $-K$. In particular, as $\tau \rightarrow 0$, we have

$$p_{-K}(t, x, y) \leq \bar{p}(t, x, y), \quad \forall (t, x, y) \in \mathbb{R}_+ \times \bar{M} \times \bar{M}. \quad (23)$$

Step 3. Upper bound. Observe that, for the upper bound, the comparison theorem cannot hold globally. We claim that there exists positive constants $C_1, C_2, C_3 > 0$, such that for any $x \in M$ and $\sqrt{t} < \min\{\rho(x), \pi/\sqrt{K}\}$, where $\rho(x)$ is defined in (19), it holds

$$\bar{p}(t, x, x) \leq p_K(t, 0) + \frac{C_1}{t^{n/2}} e^{-C_3 \frac{\rho^2(x)}{4t}} \quad \text{and} \quad \bar{p}(t, x, x^*) \leq \frac{C_1}{t^{n/2}} e^{-C_3 \frac{\rho^2(x)}{4t}}. \quad (24)$$

We use $\bar{B}_x(r)$ (resp. $\bar{B}_x^\tau(r)$) to denote the open ball with center x and radius $r > 0$ with respect to the metric \bar{d} (resp. \bar{d}_τ). When the ball is completely contained in one of the two copies of M in \bar{M} , we drop the bar since no confusion arises.

Fix $x \in M$, and let $\rho = \rho(x)$. Let $\Omega = B_x(\rho)$. By definition of ρ , the closure of $\Omega = \bar{B}_x^\tau(\rho)$ is contained in one of the two copies of $M \subset \bar{M}$, and does not intersect ∂M . Hence, assuming τ sufficiently small, we have $\bar{g}_\tau|_\Omega = g|_\Omega$, and

$$\Omega = \bar{B}_x^\tau(\rho) = \bar{B}_x(\rho) = B_x(\rho). \quad (25)$$

Denoting by p_Ω^τ the heat kernel w.r.t. \bar{g}_τ on Ω with Dirichlet boundary condition, the Markov property of the heat kernel implies that

$$\bar{p}^\tau(t, x, y) \leq \bar{p}_\Omega^\tau(t, x, y) + \sup_{\substack{0 < s \leq t \\ z \in \partial\Omega}} \bar{p}^\tau(s, z, y). \quad (26)$$

This follows, e.g., by applying [24, Lemma 3.1] and upper-bounding the hitting probability appearing there by 1. We now estimate the two terms appearing on the r.h.s. of (26), which we will refer to as the local and the global term, respectively, for the case of $y \in \{x, x^*\}$.

Let us start by considering the local term, for $y = x^*$. Since $\Omega \subset M$, it follows that $x^* \notin \Omega$, hence

$$\bar{p}_\Omega^\tau(t, x, x^*) = 0. \quad (27)$$

Let now $y = x$. Observe that since $\rho \leq \text{inj}_M$, and $\Omega = \bar{B}_x^\tau(\rho)$ lies in the region of M where the metric is unperturbed, Ω lies within the injectivity radius from x . Therefore, we can apply [10, Theorem 6, p. 194] and domain monotonicity of the Dirichlet heat kernel to obtain

$$\bar{p}_\Omega^\tau(t, x, x) \leq p_K(t, 0). \quad (28)$$

The global term in (26) is more delicate. Observe that the Li-Yau inequality (see Lemma A.4) requires only a lower bound on the Ricci curvature, and hence can be applied to the compact Riemannian manifold with no boundary (\bar{M}, \bar{g}_τ) , for which $\text{Ric}(\bar{g}_\tau) \geq -(n-1)K$, for all τ . As a consequence, there exist constants $C_1, C_2, C_3 > 0$, depending only on the dimension n of \bar{M} , such that

$$\bar{p}^\tau(s, z, y) \leq \frac{C_1}{\sqrt{\text{vol}^\tau(\bar{B}_y^\tau(\sqrt{s}))\text{vol}^\tau(\bar{B}_z^\tau(\sqrt{s}))}} e^{C_2 K s - C_3 \frac{\bar{d}_\tau^2(z, y)}{4s}}, \quad (29)$$

for all $(s, z, y) \in \mathbb{R}_+ \times \bar{M} \times \bar{M}$.

Recall that $z \in \partial \bar{B}_x^\tau(\rho)$, and $\rho(x) \leq d_\partial(x)/2$. This implies that $\bar{d}_\tau(z, x) = \rho$, and

$$\bar{d}_\tau(z, x^*) \geq \bar{d}_\tau(x, x^*) - \bar{d}_\tau(z, x) = 2d_\partial(x) - \rho \geq 3\rho \geq \rho. \quad (30)$$

Hence, (29), for $y \in \{x, x^*\}$, yields

$$\bar{p}^\tau(s, z, y) \leq \frac{C_1}{\sqrt{\text{vol}^\tau(\bar{B}_y^\tau(\sqrt{s}))\text{vol}^\tau(\bar{B}_z^\tau(\sqrt{s}))}} e^{C_2 K s - C_3 \frac{\rho^2(x)}{4s}}, \quad y \in \{x, x^*\}. \quad (31)$$

Recall now that in (26) $s \leq t$. Furthermore $\sqrt{t} \leq \rho = \min\left\{\frac{d_\partial(x)}{2}, \text{inj}_M\right\}$. It follows that $\bar{B}_y^\tau(\sqrt{s})$, for $y \in \{x, x^*\}$ appearing in (31) do not intersect ∂M , and hence we can choose τ sufficiently small in such a way that these sets lie in the region of \bar{M} where the metric is unperturbed, yielding

$$\text{vol}^\tau(\bar{B}_y(\sqrt{s})) = \text{vol}(B_y(\sqrt{s})), \quad \forall s \leq t, \quad y \in \{x, x^*\}. \quad (32)$$

Furthermore, since $\sqrt{t} \leq \text{inj}_M$, and thanks to the upper bound on the sectional curvature of (M, g) , we have

$$\text{vol}(B_y(\sqrt{s})) \geq \text{vol}(B_K(\sqrt{s})), \quad \forall s \leq t, \quad y \in \{x, x^*\}. \quad (33)$$

Finally, since $\sqrt{t} \leq \frac{\pi}{\sqrt{K}}$, we deduce (see Lemma A.2) the existence of a constant $C > 0$ depending only on n such that, for τ sufficiently small, it holds

$$\text{vol}^\tau(\bar{B}_y^\tau(\sqrt{s})) \geq C s^{n/2}, \quad \forall s \leq t, \quad y \in \{x, x^*\}. \quad (34)$$

The same argument shows that (34) holds also for $y = z \in \partial\Omega$ for τ sufficiently small. By plugging (34) in (31), and renaming the constants, we deduce that

$$\bar{p}^\tau(s, z, y) \leq \frac{C_1}{s^{n/2}} e^{-C_3 \frac{\rho^2(x)}{4s}}, \quad \forall s \leq t, \quad y \in \{x, x^*\}. \quad (35)$$

An elementary argument show that, up to replacing the constant C_1 with a larger constant (still depending only on n), one has

$$\sup_{\substack{0 < s \leq t \\ z \in \partial\Omega}} \bar{p}^\tau(s, z, y) \leq \frac{C_1}{t^{n/2}} e^{-C_3 \frac{\rho^2(x)}{4t}}, \quad y \in \{x, x^*\}, \quad (36)$$

which is the the final estimate for the global part of (26).

By (27) (resp. (28)) and (36), passing to the limit as $\tau \rightarrow 0$ in (26), completes the proof of the upper bounds (24).

Step 4. Conclusion. By (21), the lower bound (23) and the upper bound (24) for the heat kernel of the double yield the following on-diagonal estimates for the Dirichlet and Neumann heat kernels of the original manifold with boundary:

$$p_{-K}(t, 0) - \frac{C_1}{t^{n/2}} e^{-C_3 \frac{\rho^2(x)}{4t}} \leq p^\pm(t, x, x) \leq p_K(t, 0) + \frac{2C_1}{t^{n/2}} e^{-C_3 \frac{\rho^2(x)}{4t}}, \quad (37)$$

valid for all $0 < \sqrt{t} \leq \min\{\rho(x), \frac{\pi}{\sqrt{K}}\}$. We conclude by using the uniform estimates of $p_{\pm K}(t, 0)$ given in Lemma A.1 (which we apply with $T = \pi^2$). \square

2.3 Heat trace bound

In this section we apply Theorem 2.1 to estimate the heat trace on M .

Theorem 2.2 (Heat trace asymptotics with quantitative remainder). *Let (M, g) be a smooth compact n -dimensional Riemannian manifold with convex boundary ∂M . Let $K, H \geq 0$ such that $|\text{Sec}(M)| \leq K$ and $|\text{Hess}(\delta)| \leq H$ for $d_\partial < \text{inj}_{\partial M}$. Then there exists a constant $c > 0$, depending only on n , such that the following estimate for the Dirichlet and Neumann heat kernels holds:*

$$\left| \frac{(4\pi t)^{n/2}}{\text{vol}(M)} \int_M p^\pm(t, x, x) d\mu_g(x) - 1 \right| \leq c \left(\frac{t}{t_0} \right)^{1/2}, \quad (38)$$

for all values of $t \in \mathbb{R}_+$ such that

$$\sqrt{t} \leq \sqrt{t_0} = \min \left\{ \text{inj}_M, \frac{\text{inj}_{\partial M}}{2}, \frac{\pi}{\sqrt{K}}, \frac{1}{H} \right\}. \quad (39)$$

Proof. Fix t as in our assumptions. Let $\mathfrak{i} = \min\{\text{inj}_M, \frac{\text{inj}_{\partial M}}{2}\}$. We split M into 3 disjoint components (see Figure 1):

$$\Omega_1 = \left\{ \frac{d_\partial}{2} < \sqrt{t} \right\}, \quad \Omega_2 = \left\{ \sqrt{t} \leq \frac{d_\partial}{2} < \mathfrak{i} \right\}, \quad \Omega_3 = \left\{ \mathfrak{i} \leq \frac{d_\partial}{2} \right\}. \quad (40)$$

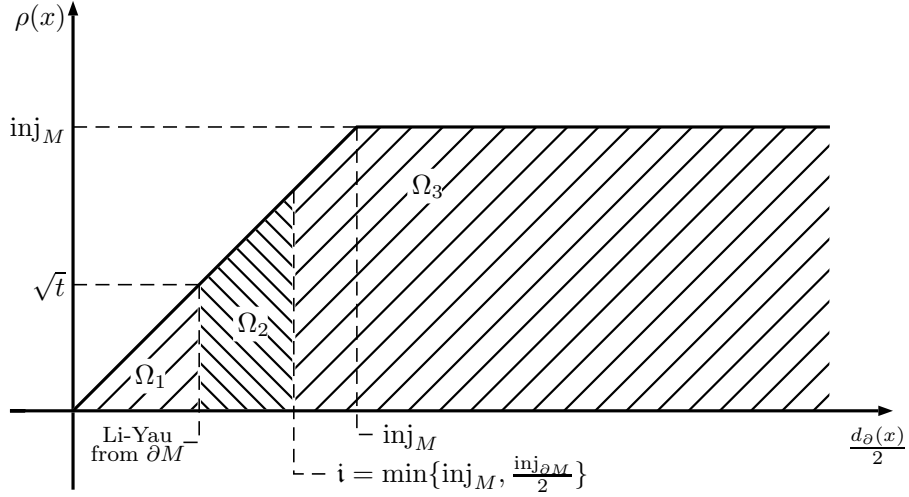

Figure 1: The regions $\Omega_1, \Omega_2, \Omega_3$. The condition $\sqrt{t} \leq \text{inj}_M$ ensures the existence of Ω_2, Ω_3 where we apply Theorem 2.1. The condition $\sqrt{t} \leq \min \left\{ \text{inj}_M, \frac{\pi}{\sqrt{K}}, \frac{\text{inj}_{\partial M}}{2}, \frac{1}{H} \right\}$ allows one to apply the Li-Yau estimate on Ω_1 .

We estimate the heat trace on these three sets separately.

Estimate on Ω_1 . By definition, and thanks to our assumption on t , we have

$$\frac{d_\partial}{2} < \sqrt{t} \leq \min \left\{ \text{inj}_M, \frac{\text{inj}_{\partial M}}{2}, \frac{\pi}{\sqrt{K}}, \frac{1}{H} \right\}. \quad (41)$$

It follows that $\rho(x) = d_\partial(x)/2$ for any $x \in \Omega_1$, where ρ is defined in (19). Furthermore, $d_\partial(x) < \text{inj}_{\partial M}$, that is, Ω_1 is contained inside the injectivity radius from the boundary. Observe that, by construction, $\sqrt{t} > \rho(x)$, and one cannot apply the bound of Theorem 2.1. However, the assumption on t allows one to apply the Li-Yau type estimate (213) of Lemma A.4. This yields,

$$(4\pi t)^{n/2} \int_{\Omega_1} p^\pm(t, x, x) d\mu_g(x) \leq C_4 \text{vol}(\Omega_1). \quad (42)$$

In order to complete the estimate on Ω_1 , we bound its volume. We have,

$$\text{vol}(\Omega_1) = \int_0^{2\sqrt{t}} \text{vol}(Z_\xi) d\xi, \quad (43)$$

where $\text{vol}(Z_\xi)$ denotes the Riemannian volume of the level set $Z_\xi = \{d_\partial = \xi\}$ (a smooth $(n-1)$ -dimensional hypersurface for $\xi > 0$, with $Z_0 = \partial M$). For all $0 < \xi \leq \text{inj}_{\partial M}$, it holds

$$\frac{d}{d\xi} \text{vol}(Z_\xi) = \int_{Z_\xi} \text{Tr}(\text{Hess}(d_\partial)) d\sigma_\xi \leq (n-1)H \text{vol}(Z_\xi), \quad (44)$$

which implies

$$\text{vol}(Z_\xi) \leq \text{vol}(\partial M) e^{(n-1)H\xi}. \quad (45)$$

Recall now that $t/t_0 \leq 1$, and hence $H\sqrt{t} \leq 1$. Thus, plugging (45) into (43) we conclude the estimate on Ω_1 , yielding

$$(4\pi t)^{n/2} \int_{\Omega_1} p^\pm(t, x, x) d\mu_g(x) \leq C_4 \text{vol}(\partial M) \sqrt{t}. \quad (46)$$

for some constant $C_4 > 0$ depending only on n .

Estimate on Ω_2 . By construction, Ω_2 still lies in the region within the injectivity radius from ∂M . Furthermore, it still holds $\rho(x) = d_\partial(x)/2$ for $x \in \Omega_2$. Here, however, $\sqrt{t} \leq \min\{\rho(x), \frac{\pi}{\sqrt{K}}\}$, and hence we can apply the result of Theorem 2.1. In particular, denoting with c a generic positive constant depending only on the dimension, whose value can be possibly increased at each step, we have

$$\int_{\Omega_2} \left| (4\pi t)^{n/2} p^\pm(t, x, x) - 1 \right| d\mu_g(x) \leq \int_{\Omega_2} \left(cKt + ce^{-\frac{\rho^2(x)}{ct}} \right) d\mu_g(x) \quad (47)$$

$$= cK \text{vol}(\Omega_2)t + c \int_{\Omega_2} e^{-\frac{d_\partial^2(x)}{ct}} d\mu_g(x) \quad (48)$$

$$= cK \text{vol}(\Omega_2)t + c \int_{2\sqrt{t}}^i e^{-\frac{\xi^2}{ct}} \text{vol}(Z_\xi) d\xi \quad (49)$$

$$\leq cK \text{vol}(\Omega_2)t + c \text{vol}(\partial M) \int_0^\infty e^{-\frac{\xi^2}{ct} + (n-1)H\xi} d\xi \quad (50)$$

$$\leq cK \text{vol}(\Omega_2)t + c \text{vol}(\partial M) \sqrt{t}. \quad (51)$$

Here, similarly as the case for Ω_1 , we used the fact that Ω_2 lies within the injectivity radius from ∂M , and the estimate (45). Furthermore, we evaluate explicitly the Gaussian integral in the last inequality, and use the fact that $H\sqrt{t} \leq 1$.

Estimate on Ω_3 . For $x \in \Omega_3$, it does not necessarily hold $\rho(x) = d_\partial(x)/2$, neither x is forcibly within the injectivity radius from ∂M . However, it holds $\rho(x) \geq i$. Since we have $\sqrt{t} \leq i$, this implies that $\sqrt{t} \leq \rho(x)$, and we can apply Theorem 2.1 again. Hence, we obtain

$$\int_{\Omega_3} \left| (4\pi t)^{n/2} p^\pm(t, x, x) - 1 \right| d\mu_g(x) \leq \int_{\Omega_3} \left(cKt + ce^{-\frac{\rho^2(x)}{ct}} \right) d\mu_g(x) \quad (52)$$

$$\leq \left(cKt + ce^{-\frac{i^2}{ct}} \right) \text{vol}(\Omega_3) \quad (53)$$

$$\leq c \left(Kt + \frac{t}{i^2} \right) \text{vol}(\Omega_3). \quad (54)$$

Here, in the last step, we used the inequality $e^{-1/x} \leq x/e$ for $x > 0$.

Since $\text{vol}(\Omega_i)/\text{vol}(M) \leq 1$, splitting the l.h.s. of (38) in the subsets $\Omega_1, \Omega_2, \Omega_3$, using (46), (51), (54), and increasing the constants, yields

$$\left| \frac{(4\pi t)^{n/2}}{\text{vol}(M)} \int_M p^\pm(t, x, x) d\mu_g(x) - 1 \right| \leq c \left(\frac{\text{vol}(\partial M)}{\text{vol}(M)} \sqrt{t} + Kt + \frac{t}{i^2} \right) \quad (55)$$

$$\leq c \left(\frac{\text{vol}(\partial M)}{\text{vol}(M)} \sqrt{t} + \frac{t}{t_0} \right), \quad (56)$$

where we used the definition of t_0 . It only remains to estimate the ratio $\text{vol}(\partial M)/\text{vol}(M)$ in (56). Recall that $Z_x = \{d_\partial = x\}$. The lower bound on the Hessian yields

$$\frac{d}{dx} \text{vol}(Z_x) = \int_{Z_x} \text{Tr}(\text{Hess}(d_\partial)) d\sigma_x \geq -H(n-1) \text{vol}(Z_x), \quad \forall x \leq \text{inj}_{\partial M}. \quad (57)$$

Integrating the above, we have

$$\text{vol}(Z_x) \geq \text{vol}(\partial M)e^{-H(n-1)x}, \quad \forall x \leq \text{inj}_{\partial M}. \quad (58)$$

Therefore, since $t_0 \leq \mathbf{i}^2$ and $H\sqrt{t_0} \leq 1$, we have

$$\frac{\text{vol}(M)}{\text{vol}(\partial M)} \geq \int_0^{\sqrt{t_0}/(n-1)} \frac{\text{vol}(Z_x)}{\text{vol}(\partial M)} dx \geq \frac{1 - e^{-H\sqrt{t_0}}}{H(n-1)} \geq \frac{\sqrt{t_0}(1 - e^{-1})}{n-1}. \quad (59)$$

Plugging this estimate in (56), and using the fact that $t/t_0 \leq 1$ yields the result. \square

In the next corollary, we present a weaker but simpler statement, in global form.

Corollary 2.3 (Heat trace asymptotics with quantitative remainder, global form). *In the setting of Theorem 2.2, there exists a constant $c > 0$, depending only on the dimension n , such that*

$$\left| \frac{(4\pi t)^{n/2}}{\text{vol}(M)} \int_M p^\pm(t, x, x) d\mu_g(x) - 1 \right| \leq c \begin{cases} (t/t_0)^{1/2} & t \leq t_0, \\ (t/t_0)^{n/2} & t \geq t_0, \end{cases} \quad (60)$$

where $\sqrt{t_0} = \min \left\{ \text{inj}_M, \frac{\text{inj}_{\partial M}}{2}, \frac{\pi}{\sqrt{K}}, \frac{1}{H} \right\}$ is defined in (39).

Proof. Assume that $t \geq t_0$, and let here $W(t) = \frac{(4\pi)^{n/2}}{\text{vol}(M)} \int_M p^\pm(t, x, x) d\mu_g(x)$. Since $W(t)$ is decreasing and positive, we have

$$\left| W(t) - t^{-n/2} \right| \leq W(t_0) + t_0^{-n/2} \quad (61)$$

$$\leq \left| W(t_0) - t_0^{-n/2} \right| + 2t_0^{-n/2} \quad (62)$$

$$\leq t_0^{-n/2} R(t_0) + 2t_0^{-n/2} \quad (63)$$

$$\leq t_0^{-n/2} (c + 2). \quad (64)$$

Therefore, up to modifying again c , we obtain

$$R(t) = \left| t^{n/2} W(t) - 1 \right| \leq c \left(\frac{t}{t_0} \right)^{n/2}, \quad \forall t \geq t_0, \quad (65)$$

concluding the proof. \square

2.4 Weyl's law with remainder

When M is compact, the spectrum of $-\Delta_\Omega^\pm$ is a discrete subset of the positive real axis, i.e., $\sigma(-\Delta^\pm) \subset [0, +\infty)$, accumulating at infinity. The Weyl counting function is then defined as

$$N^\pm(\lambda) = \#(\sigma(-\Delta^\pm) \cap [0, \lambda]). \quad (66)$$

It is well known that heat trace asymptotics imply asymptotics for the Weyl counting function, by means of Tauberian theorems in the form of Karamata [27]. We need here a Karamata-type of result with remainder, due to Ingham [26, Theorem B]. Due to the fact that, for our purposes, we need to know the explicit dependence of the constants with respect to all parameters and functions at play, the statement below is slightly more precise than the one in [26]. Since the proof is unchanged, we omit it.

Theorem 2.4 (Ingham's Tauberian Theorem [26]). *Let $\mu : [0, \infty) \rightarrow \mathbb{R}$ be a positive and non-decreasing function. Denote with the same symbol the associated Stieltjes measure. Let $\alpha > -1$, and let $\chi : [0, +\infty) \rightarrow \mathbb{R}$ be a function such that*

$$\chi(\lambda) > 0, \quad \chi(\lambda) \nearrow \infty, \quad \lambda^{-\alpha-1}\chi(\lambda) \searrow, \quad \forall \lambda > 0. \quad (67)$$

Let $\hat{\mu}(t) = \int_0^\infty e^{-t\lambda} d\mu(\lambda)$ denote the Laplace transform of μ . Suppose that there exists $c_1 > 0$ such that

$$|t^\alpha \hat{\mu}(t) - 1| \leq \frac{c_1}{\chi(1/t)}, \quad \forall t > 0. \quad (68)$$

Then there exists another constant $c_2 = c_2(c_1, \alpha) > 0$ such that

$$\left| \frac{\Gamma(\alpha + 1)\mu(\lambda)}{\lambda^\alpha} - 1 \right| \leq \frac{c_2}{\log(\chi(\lambda) + 1)}, \quad \forall \lambda > 0. \quad (69)$$

Remark 2.1. Theorem 2.4 in particular recovers the classical statement of Karamata: if $\hat{\mu}(t) \sim t^{-\alpha}$ as $t \rightarrow 0$, then $\mu(\lambda) \sim \lambda^\alpha/\Gamma(\alpha + 1)$ as $\lambda \rightarrow \infty$.

We use Corollary 2.3 to derive the Weyl law with remainder for M . In order to do that, we define the function $\chi : \mathbb{R}_+ \rightarrow \mathbb{R}$ by

$$\frac{1}{\chi(\lambda)} := \begin{cases} (\lambda_0/\lambda)^{1/2} & \lambda \geq \lambda_0, \\ (\lambda_0/\lambda)^{n/2} & \lambda \leq \lambda_0. \end{cases} \quad (70)$$

Observe that χ is obtained by replacing t with $1/\lambda$ in the remainder given by Corollary 2.3. Here $\lambda_0 = 1/t_0$ which, using (39), is

$$\sqrt{\lambda_0} = \frac{1}{\min \left\{ \text{inj}_M, \frac{\text{inj}_{\partial M}}{2}, \frac{\pi}{\sqrt{K}}, \frac{1}{H} \right\}}. \quad (71)$$

Theorem 2.5 (Weyl law with quantitative remainder). *In the setting of Theorem 2.2, there exists a constant $c > 0$ depending only on n , such that the following estimate holds for the Weyl counting function for the Dirichlet or Neumann eigenvalues:*

$$\left| \frac{N(\lambda)}{\frac{\omega_n}{(2\pi)^n} \text{vol}(M) \lambda^{n/2}} - 1 \right| \leq \frac{c}{\log(\chi(\lambda) + 1)}, \quad \forall \lambda > 0. \quad (72)$$

Proof. The proof is an application of Theorem 2.4. Indeed, observe that

$$\int_M p^\pm(t, x, x) d\mu_g(x) = \sum_{i=1}^\infty e^{-t\lambda_i} = \int_0^\infty e^{-t\lambda} dN(\lambda). \quad (73)$$

Moreover, by Corollary 2.3, the assumptions in Theorem 2.4 are satisfied with $\alpha = n/2$, χ defined in (70), and letting

$$\mu(\lambda) = \frac{(4\pi)^{n/2}}{\text{vol}(M)} N(\lambda). \quad (74)$$

Recalling that $\Gamma(\frac{n}{2} + 1) = \frac{\pi^{n/2}}{\omega_n}$ yields the result. \square

The upper bound part of Theorem 2.5 can be seen a version of Buser's inequality with sharp leading order constant as $\lambda \rightarrow \infty$. The price to pay for sharpness is a stronger curvature assumption (Buser's inequality for closed manifolds only requires a Ricci lower bound, see [9]). See also [25, Sec. 1.2] and references therein for a more detailed discussion on Buser's and related inequalities. If one does not require a sharp leading constant, the upper bound of Theorem 2.5 can be restated in a strictly weaker form as follows.

Corollary 2.6 (Buser's type inequality). *In the setting of Theorem 2.2, there exists a constant $C > 0$ depending only on n , such that the following estimate holds for the Weyl counting function for the Dirichlet or Neumann eigenvalues:*

$$N(\lambda) \leq C \text{vol}(M) \left(\lambda^{n/2} + \text{inj}_M^{-n} + \text{inj}_{\partial M}^{-n} + K^{n/2} + H^n \right), \quad \forall \lambda > 0. \quad (75)$$

3 Geometric structure at the singularity

In this section we collect some preliminary results on the structure of Riemannian manifolds \mathcal{M} satisfying Assumption (Σ) .

We denote by $\widehat{\mathcal{M}}$ the metric completion of \mathcal{M} w.r.t. the Riemannian distance and by $\partial\mathcal{M} = \widehat{\mathcal{M}} \setminus \mathcal{M}$ the metric boundary. The distance from the metric boundary is denoted by δ . Recall that δ is Lipschitz and satisfies the eikonal equation, i.e., $|\nabla\delta| \equiv 1$.

For any $0 \leq a < b \leq +\infty$, we let $\mathcal{M}_a^b = \{a \leq \delta \leq b\} \cap \mathcal{M}$. The following lemma collects some basic properties of \mathcal{M} .

Lemma 3.1. *Let \mathcal{M} be a Riemannian manifold satisfying Assumptions (Σ) . Then there exists $\varepsilon_0 > 0$ such that:*

- i. For any $\varepsilon < \varepsilon_0$ the level sets $\mathcal{Z}_\varepsilon = \{\delta = \varepsilon\}$ are smooth embedded submanifolds. Then, letting $\mathcal{Z} = \mathcal{Z}_{\varepsilon_0}$, we have the identification $\mathcal{M}_0^{\varepsilon_0} \simeq (0, \varepsilon_0] \times \mathcal{Z}$ with $\delta(x, z) = x$ for $(x, z) \in (0, \varepsilon_0] \times \mathcal{Z}$. In particular, there exists a one-parameter family $(h(x))_{x \in (0, \varepsilon_0]}$ of Riemannian metrics on \mathcal{Z} such that*

$$g = dx^2 + h(x), \quad \text{on } \mathcal{M}_0^\varepsilon \simeq (0, \varepsilon_0] \times \mathcal{Z}. \quad (76)$$

Moreover, for any vector V tangent to \mathcal{Z} , the map $x \mapsto h_x(V, V)$ is non-increasing.

- ii. There exists a constant $C > 0$ such that, for all $\varepsilon < \varepsilon_0$, it holds*

$$\text{inj}_{\partial\mathcal{M}_\varepsilon^\infty} \geq \varepsilon_0, \quad \text{Hess } \delta|_{T\mathcal{Z}_\varepsilon} \geq -\frac{C}{\varepsilon}. \quad (77)$$

Proof. The first part of the statement is an immediate consequence of the smoothness of δ near the metric boundary. The fact that $x \mapsto h(x)$ is a non-increasing family of Riemannian metrics follows from the convexity assumption.

Furthermore for all $\varepsilon \leq \varepsilon_0$ the truncation $\mathcal{M}_\varepsilon^\infty$ admits an inward tubular neighborhood of its boundary, given by $\mathcal{M}_\varepsilon^{\varepsilon_0}$, on which the metric is the restriction of

(76) to $(\varepsilon, \varepsilon_0] \times \mathcal{Z}_{\varepsilon_0}$. Hence, the distance from its boundary $\partial\mathcal{M}_\varepsilon^\infty = \mathcal{Z}_\varepsilon \simeq \mathcal{Z}_{\varepsilon_0}$, satisfies

$$d_\partial(x, z) = \delta(x, z) - \varepsilon = x - \varepsilon. \quad (78)$$

Up to halving ε_0 this proves the bound on the injectivity radius in the second statement. Finally, the bound on the Hessian matrix follows by the geometric bounds on the sectional curvatures, and the fact that $\text{Hess}\delta$ and Sec are connected by a Riccati equation (see, [37, Proposition 7]). \square

Proposition 3.2. *Let \mathcal{M} be a singular Riemannian manifold with compact metric completion satisfying (Σ) . If the convexity condition (b) is assumed to be strict (i.e. $\text{Hess}(\delta) < 0$), then the injectivity radius condition (d) is automatically verified.*

Proof. Let $p, q \in \mathcal{M}$. Let $\gamma : [0, 1] \rightarrow \mathcal{M}$ be a piecewise smooth curve joining p and q . Let $I \subset [0, 1]$ be a maximal interval such that

$$\delta(\gamma(t)) < \min\{\delta(p), \delta(q), \varepsilon_0\}, \quad \forall t \in I. \quad (79)$$

In particular, $\gamma(I) \subseteq \mathcal{M}_0^{\varepsilon_0} \simeq (0, \varepsilon_0) \times Z$, with $g = dx^2 + h(x)$, where $h(x)$ is a one-parameter family of smooth metrics on Z . Since $\text{Hess}(\delta) \leq 0$, and $\delta(x, z) = x$, it follows that $x \mapsto h(x)$ is non-increasing. Thus, replacing on I the curve $\gamma(t) = (x(t), z(t))$ with its projection $(x(\partial I), z(t))$ will yield a shorter piecewise smooth curve between p and q . It follows that in order to minimize the length of curves between points of \mathcal{M} , we can restrict to curves such that

$$\delta(\gamma(t)) \geq \min\{\delta(p), \delta(q), \varepsilon_0\}, \quad \forall t \in [0, 1], \quad (80)$$

which are well separated from the metric boundary of \mathcal{M} . It follows that for any $p, q \in \mathcal{M}$ there exist a minimizing curve joining them, any such a curve is a Riemannian geodesic, and any such a geodesic respects (80).

In particular, if $p, q \in \mathcal{M}_\varepsilon$ there exists a minimizing geodesic all contained in \mathcal{M}_ε joining them (which a fortiori a minimizing geodesic of \mathcal{M}_ε). Thus, taking into account the definition of inj for a manifold with boundary, the proof of the classical Klingenberg Lemma (cf. [12, Ch. 5]) holds unchanged, and

$$\text{inj}_{\mathcal{M}_\varepsilon} \geq \min \left\{ \frac{\pi}{\sqrt{K_\varepsilon}}, \frac{\ell_\varepsilon}{2} \right\}, \quad (81)$$

where $K_\varepsilon = C/\varepsilon^2$ is the upper bound on the sectional curvature of \mathcal{M}_ε , and ℓ_ε is the shortest simple closed geodesic in \mathcal{M}_ε .

Let $\gamma : [0, 1] \rightarrow \mathcal{M}$ be such a shortest closed geodesic. Let t_0 be a point of closest distance from the metric boundary. Assuming that $t_0 < \varepsilon_0$, we have

$$(\delta \circ \gamma)''(t_0) = \text{Hess}(\delta)(\dot{\gamma}(t_0), \dot{\gamma}(t_0)) < 0. \quad (82)$$

This is a contradiction. It follows that $\delta(\gamma(t)) \geq \varepsilon_0$ for all $t \in [0, 1]$, and the length of the closed geodesic in (81) does not depend on ε . We conclude by (81). \square

The following volume estimate will come handy in many proofs.

Lemma 3.3 (Relative volume estimates). *Let \mathcal{M} be a non-complete Riemannian manifold with tame singular geometry. Then there exists $C' > 0$ such that, for any $0 < a \leq b \leq \varepsilon_0$ we have*

$$\frac{\text{vol}(\mathcal{M}_b^\infty)}{\text{vol}(\mathcal{M}_a^\infty)} \geq \left(\frac{a}{b}\right)^{1/C'} \quad (83)$$

Proof. The regularity of the metric boundary allows to write, thanks to (76)

$$\text{vol}(\mathcal{M}_\varepsilon^\infty) = \int_\varepsilon^{\varepsilon_0} \text{vol}(\mathcal{Z}_x) dx + \text{vol}(\mathcal{M}_{\varepsilon_0}^\infty). \quad (84)$$

The lower bound on the Hessian given by Lemma 3.1(ii) yields that $m(\partial\mathcal{M}_x^\infty) \geq (n-1)C\varepsilon^{-2}$. This implies that, up to enlarging C ,

$$\frac{d}{dx} \text{vol}(\mathcal{Z}_x) = \int_{\mathcal{Z}_x} m(\partial\mathcal{M}_x^\infty) d\sigma_x \geq -\frac{C}{x} \text{vol}(\mathcal{Z}_x), \quad \forall x \leq \varepsilon_0. \quad (85)$$

By Gronwall's Lemma, this yields

$$\frac{\text{vol}(\mathcal{Z}_x)}{\text{vol}(\mathcal{Z}_\varepsilon)} \geq \left(\frac{\varepsilon}{x}\right)^C, \quad \forall x \in [\varepsilon, \varepsilon_0]. \quad (86)$$

Combining (84) with (86) we obtain

$$\frac{\text{vol}(\mathcal{M}_\varepsilon^\infty)}{\text{vol}(\mathcal{Z}_\varepsilon)} \geq \int_\varepsilon^{\varepsilon_0} \left(\frac{\varepsilon}{x}\right)^C dx = \varepsilon \int_1^{\varepsilon_0/\varepsilon} \left(\frac{1}{x}\right)^C dx. \quad (87)$$

The r.h.s. of the above inequality is larger than or equal to $C'\varepsilon$ provided that, e.g., $\varepsilon \leq \varepsilon_0/2$. By continuity, it follows that, up to reducing C' we have

$$\frac{\text{vol}(\mathcal{M}_\varepsilon^\infty)}{\text{vol}(\mathcal{Z}_\varepsilon)} \geq C'\varepsilon, \quad \forall \varepsilon \leq \varepsilon_0. \quad (88)$$

Note that (88) is equivalent to

$$\frac{d}{d\varepsilon} \log \text{vol}(\mathcal{M}_\varepsilon^\infty) \geq -\frac{1}{C'\varepsilon}, \quad \forall \varepsilon \leq \varepsilon_0, \quad (89)$$

which yields (83) upon integration. \square

4 Weyl's asymptotics for singular manifolds

Let \mathcal{M} be a Riemannian manifold satisfying Assumption (Σ) and with compact metric completion. We recall that for $\Omega \subset \mathcal{M}$ the Friedrichs (or Dirichlet) Laplace-Beltrami operator Δ_Ω^+ is the operator on $L^2(\Omega)$ associated with the quadratic form

$$Q(u) = \int_\Omega |\nabla u|^2 d\mu_g, \quad (90)$$

with domain $H_0^1(\mathcal{M})$, i.e., the closure of $C_c^\infty(\Omega)$ w.r.t. the scalar product naturally associated with Q . On the other hand, we let the Neumann Laplace-Beltrami Δ_Ω^-

operator be the operator associated with the same form, but with domain $H^1(\Omega) = \{u \in C^\infty(\Omega) \cap L^2(\Omega) \mid Q(u) < +\infty\}$. Here, we let $C^\infty(\Omega)$ be the space of restrictions of functions in $C_c^\infty(\mathcal{M})$ to Ω . Observe that, by Corollary B.3, if $\partial\Omega \cap \mathcal{M}$ has Lipschitz boundary, then Δ_Ω^\pm have discrete spectrum. Then, for $0 \leq a < b \leq \infty$, we denote by $N_{[a,b]}^\pm(\lambda)$ the Weyl counting functions associated with $\Delta_{\mathcal{M}_a^\pm}^\pm$.

In this section we prove asymptotics for the counting function $N(\lambda)$ of the Friedrichs Laplace-Beltrami operator on \mathcal{M} . The strategy of proof is based on the following instance of Dirichlet-Neumann bracketing (see [19, p. 407]), adapted to our setting.

Proposition 4.1 (Dirichlet-Neumann bracketing). *Let \mathcal{M} be a non-complete Riemannian manifold with compact metric completion and regular metric boundary. Assume, moreover, that $\partial\mathcal{M}$ is mean convex. Then, for any $0 = a_0 < a_1 < \dots < a_{n+1} = +\infty$, we have*

$$\sum_{i=0}^n N_{[a_i, a_{i+1}]}^-(\lambda) \leq N(\lambda) \leq \sum_{i=0}^n N_{[a_i, a_{i+1}]}^+(\lambda), \quad \forall \lambda \geq 0. \quad (91)$$

The argument consists in the following steps:

1. Consider the exhaustion $\mathcal{M}_\varepsilon^\infty$, for $\varepsilon \leq \varepsilon_0$. Use then Theorem 2.5 to obtain a Weyl's law $N_{[\varepsilon, \infty]}(\lambda)$ of $\mathcal{M}_\varepsilon^\infty$, with an explicit remainder term
2. Relate ε to λ so that $\varepsilon \rightarrow 0$ as $\lambda \rightarrow \infty$, and that the remainder term in $N_{[\varepsilon(\lambda), \infty]}(\lambda)$ is controlled as $\lambda \rightarrow \infty$.

A first essential step is to discard the contributions to $N(\lambda)$ of the regions near the metric boundary for quantitatively small values of λ . This is the purpose of the following Lemma, which is an immediate consequence of the minmax principle and the Hardy inequality given by Proposition B.1.

Lemma 4.2 (Spectral estimates at the metric boundary). *Let \mathcal{M} be a Riemannian manifold satisfying Assumption (Σ) and with compact metric completion. Then, for $\varepsilon < \varepsilon_0/2$, it holds*

$$N_{[0, \varepsilon]}^\pm(\lambda) = 0, \quad \forall \lambda < \frac{1}{8\varepsilon^2}. \quad (92)$$

We are now ready to state and prove the main result of this section.

Theorem 4.3. *Let \mathcal{M} be a Riemannian manifold satisfying Assumption (Σ) and with compact metric completion. Then, there exist $C_\pm > 0$ and $\Lambda > 0$ such that*

$$C_- \leq \frac{N(\lambda)}{\lambda^{n/2} \text{vol}(\mathcal{M}_{1/\sqrt{\lambda}}^\infty)} \leq C_+, \quad \forall \lambda \geq \Lambda. \quad (93)$$

Proof. Let $0 < \varepsilon \leq \varepsilon_0$. We split \mathcal{M} into two parts $\mathcal{M} = \mathcal{M}_0^\varepsilon \cup \mathcal{M}_\varepsilon^\infty$. Thanks to all our assumptions, by Theorem 2.5, we have

$$\left| \frac{(2\pi)^n}{\omega_n \text{vol}(\mathcal{M}_\varepsilon^\infty) \lambda^{n/2}} N_{[\varepsilon, \infty]}^\pm(\lambda) - 1 \right| \leq \frac{c}{\log(\chi(\lambda) + 1)}, \quad \forall \lambda > 0, \quad (94)$$

where $\chi(\lambda)$ is given in (70). By our assumptions, there exists a constant $b > 0$, depending only on the dimension, such that $\lambda_0 = b/\varepsilon^2$ (for simplicity, we set this constant to 1 in the following). In particular, we have

$$\chi(\lambda) = \min \left\{ (\varepsilon^2 \lambda)^{1/2}, (\varepsilon^2 \lambda)^{n/2} \right\}. \quad (95)$$

Our aim is to let $\varepsilon \rightarrow 0$ as fast as possible, as $\lambda \rightarrow \infty$, while keeping $\varepsilon^2 \lambda$ bounded in order to be able to control the remainder term. Hence, we set $\varepsilon = \varepsilon_a(\lambda)$ where

$$\varepsilon_a(\lambda) := \frac{1}{\sqrt{a\lambda}}, \quad a > 0. \quad (96)$$

In this case the remainder in (94) is bounded by a constant, depending only on the dimension and on a , which can be made arbitrarily small as $a \rightarrow 0$.

In the rest of the proof, by considering two cases in which a is large and small, we obtain the upper and lower bound for $N(\lambda)$, respectively.

Upper bound. Choose $a_+ > 8$ and set $\varepsilon = \varepsilon_{a_+}(\lambda)$ as described above. Then, Lemma 4.2 yields $N_{[0,\varepsilon]}^\pm(\lambda) = 0$ for $\lambda \geq \Lambda := 4/\varepsilon_0^2 a_+$. Hence, by Neumann bracketing (i.e., the r.h.s. of the statement of Proposition 4.1) we obtain that there exists $C_+ > 0$ independent of λ and such that for all $\lambda \geq \Lambda$ it holds

$$N(\lambda) \leq N_{[0,\varepsilon]}^+(\lambda) + N_{[\varepsilon,\infty]}^+(\lambda) \leq N_{[\varepsilon,\infty]}^+(\lambda) \leq C_+ \lambda^{n/2} \text{vol} \left(\mathcal{M}_{1/\sqrt{a_+\lambda}}^\infty \right). \quad (97)$$

Lower bound. In this case we can always neglect the boundary contribution, since $N_{[0,\varepsilon]}^-(\lambda) \geq 0$. By Dirichlet bracketing (i.e., the l.h.s. of the statement of Proposition 4.1), we have

$$N(\lambda) \geq N_{[0,\varepsilon]}^-(\lambda) + N_{[\varepsilon,\infty]}^-(\lambda) \geq N_{[\varepsilon,\infty]}^-(\lambda), \quad \forall \varepsilon \leq \varepsilon_0. \quad (98)$$

Choose a_- sufficiently small, and $\varepsilon = \varepsilon_{a_-}(\lambda)$, in such a way that the remainder term in (94) is smaller than 1. We deduce that there exists a constant $C_- > 0$ such that

$$N(\lambda) \geq N_{[\varepsilon,\infty]}^-(\lambda) \geq C_- \lambda^{n/2} \text{vol} \left(\mathcal{M}_{1/\sqrt{a_-\lambda}}^\infty \right), \quad \forall \lambda > 0. \quad (99)$$

To conclude the proof it suffices to apply Lemma 3.3 to (99) and (97). \square

Remark 4.1. The proof of Theorem 4.3 shows that the estimate of Theorem 2.2 (and in turn Theorem 4.3 itself) cannot be improved. To see that, suppose that we are able to deduce a better remainder, in such a way that by setting

$$\varepsilon = \frac{1}{\sqrt{a\lambda}}, \quad (100)$$

the remainder of Theorem 2.2 is negligible, and not simply bounded, as $\lambda \rightarrow \infty$. For the upper bound, arguing as above, we obtain the estimate

$$\limsup_{\lambda \rightarrow \infty} \frac{N(\lambda)}{\lambda^{n/2} \text{vol}(\mathcal{M}_{1/\sqrt{\lambda}}^\infty)} \leq \frac{\omega_n}{(2\pi)^n} a_+^{1/2C'}, \quad (101)$$

where we used Lemma 3.3 to compute $\text{vol}(\mathcal{M}_{1/\sqrt{a\lambda}}^\infty)/\text{vol}(\mathcal{M}_{1/\sqrt{\lambda}}^\infty) = a^{1/2C'}$. Note that, to get rid of the boundary terms by Lemma 4.2, we need to choose $a_+ > 8$. Hence, the best upper bound in (101) is obtained for $a_+ = 8$, and cannot be improved further. For the lower bound, we obtain

$$\liminf_{\lambda \rightarrow \infty} \frac{N(\lambda)}{\lambda^{n/2} \text{vol}(\mathcal{M}_{1/\sqrt{\lambda}}^\infty)} \geq \frac{\omega_n}{(2\pi)^n} a_-^{1/2C'}. \quad (102)$$

In this case there is no constraint on a_- , which can be chosen as large as we want, obtaining a contradiction with (101).

5 Exact Weyl's law for slowly varying volume

In this section we obtain a stronger version of Theorem 4.3, under an additional assumption on the volume growth. Recall that a continuous function $\ell : \mathbb{R}_+ \rightarrow \mathbb{R}_+$ is slowly varying at ∞ in the sense of Karamata [6] if for all $a > 0$ it holds

$$\lim_{x \rightarrow \infty} \frac{\ell(ax)}{\ell(x)} = 1. \quad (103)$$

One can show that the above limit is uniform for a in compact intervals.

Example 5.1. Examples of slowly varying functions, cf. [6], are $\log x$, the iterates $\log_k x = \log_{k-1} \log x$, rational functions with positive coefficients formed with the $\log_k x$. Non-logarithmic examples are

$$\exp((\log x)^{\alpha_1} \dots (\log_k x)^{\alpha_k}), \quad 0 < \alpha_i < 1. \quad (104)$$

One might also have infinitely oscillating functions as

$$\exp((\log x)^{1/3} \cos(\log x)^{1/3}). \quad (105)$$

Clearly, any function with finite limit is slowly varying.

Theorem 5.1. *Let \mathcal{M} be a Riemannian manifold satisfying Assumption (Σ) and with compact metric completion. Assume, moreover, that the function*

$$v(\lambda) := \text{vol}(\mathcal{M}_{1/\sqrt{\lambda}}^\infty), \quad (106)$$

is slowly varying. Then, we have

$$\lim_{\lambda \rightarrow \infty} \frac{N(\lambda)}{\lambda^{n/2} v(\lambda)} = \frac{\omega_n}{(2\pi)^n}. \quad (107)$$

Proof. We prove that

$$\frac{\omega_n}{(2\pi)^n} \leq \liminf_{\lambda \rightarrow \infty} \frac{N(\lambda)}{\lambda^{n/2} v(\lambda)} \leq \limsup_{\lambda \rightarrow \infty} \frac{N(\lambda)}{\lambda^{n/2} v(\lambda)} \leq \frac{\omega_n}{(2\pi)^n}. \quad (108)$$

The proof of the lower bound starts as in the proof of Theorem 4.3, i.e., by splitting $\mathcal{M} = \mathcal{M}_\varepsilon^\infty \cup \mathcal{M}_0^\varepsilon$, for $\varepsilon \leq \varepsilon_0$. We have

$$N(\lambda) \geq N_{[0, \varepsilon]}^- + N_{[\varepsilon, \infty]}^-(\lambda) \geq N_{[\varepsilon, \infty]}^-(\lambda). \quad (109)$$

Choose $a > 0$ sufficiently small, and let $\varepsilon = 1/\sqrt{a\lambda}$. From (94) we deduce the existence of a constant $C(a)$, tending to 0 as $a \rightarrow 0$, such that

$$N(\lambda) \geq N_{[\varepsilon, \infty]}^-(\lambda) \geq \frac{\omega_n}{(2\pi)^n} \lambda^{n/2} v(a\lambda) (1 + C(a)). \quad (110)$$

We now use the fact that $v(\lambda)$ is slowly varying to obtain

$$\liminf_{\lambda \rightarrow \infty} \frac{N(\lambda)}{\lambda^{n/2} v(\lambda)} \geq \frac{\omega_n}{(2\pi)^n} (1 + C(a)). \quad (111)$$

By letting $a \rightarrow 0$ we conclude the proof of the lower bound.

The proof of the upper bound is more delicate. In this case, we split \mathcal{M} into three parts. Let $0 < \varepsilon_1 < \varepsilon_2$ sufficiently small, and let

$$\mathcal{M} = \mathcal{M}_0^{\varepsilon_1} \cup \mathcal{M}_{\varepsilon_1}^{\varepsilon_2} \cup \mathcal{M}_{\varepsilon_2}^{\infty}. \quad (112)$$

Consider $a < 1$ small enough, and let

$$\varepsilon_1(\lambda) := \frac{1}{10\sqrt{\lambda}}, \quad \varepsilon_2(\lambda) := \frac{1}{\sqrt{a\lambda}}. \quad (113)$$

The factor 10 above has been chosen in order to be able to apply Lemma 4.2, whence $N_{[0, \varepsilon_1(\lambda)]}^+(\lambda) = 0$. By Neumann bracketing we obtain

$$N(\lambda) \leq N_{[\varepsilon_1(\lambda), \varepsilon_2(\lambda)]}^+(\lambda) + N_{[\varepsilon_2(\lambda), \infty]}^+(\lambda). \quad (114)$$

In Proposition 5.2 we show that, thanks to the slowly varying assumption, the first term in (114) gives a negligible contribution to the asymptotics, more precisely

$$\lim_{\lambda \rightarrow \infty} \frac{N_{[\varepsilon_1(\lambda), \varepsilon_2(\lambda)]}^+(\lambda)}{\lambda^{n/2} v(\lambda)} = 0. \quad (115)$$

On the other hand, applying Theorem 2.5 to $\mathcal{M}_{\varepsilon_2(\lambda)}^{\infty}$, we obtain that for all $\lambda > 0$

$$N_{[\varepsilon_2(\lambda), \infty]}^+(\lambda) \leq \frac{\omega_n}{(2\pi)^n} \text{vol}(\mathcal{M}_{\varepsilon_2(\lambda)}^{\infty}) \lambda^{n/2} (1 + C(a)), \quad (116)$$

where $C(a) \rightarrow 0$ as $a \rightarrow 0$. Since v is slowly varying we have

$$\text{vol}(\mathcal{M}_{\varepsilon_2(\lambda)}^{\infty}) \sim v(\lambda). \quad (117)$$

Putting together the contributions from (115)-(116), we finally get

$$\limsup_{\lambda \rightarrow \infty} \frac{N(\lambda)}{\lambda^{n/2} v(\lambda)} \leq \frac{\omega_n}{(2\pi)^n} (1 + C(a)). \quad (118)$$

Letting $a \rightarrow 0$, we have $C(a) \rightarrow 0$, which completes the proof. \square

The following proposition estimates the number of eigenvalues in the intermediate strip $\mathcal{M}_{\varepsilon_1}^{\varepsilon_2}$ close to the singularity.

Proposition 5.2. *Let \mathcal{M} be a Riemannian manifold satisfying Assumption (Σ) and with compact metric completion. There exist a constant $C > 0$ such that, for any $0 < \varepsilon_1 < \varepsilon_2 < \varepsilon_0$, it holds*

$$N_{[\varepsilon_1, \varepsilon_2]}^\pm(\lambda) \leq C \text{vol}(\mathcal{Z}_{\varepsilon_1})(\varepsilon_2 - \varepsilon_1) \left(\frac{\varepsilon_2}{\varepsilon_1}\right)^{C/2} \lambda^{n/2}, \quad \forall \lambda > \left(\frac{\varepsilon_2}{\varepsilon_1}\right)^{-C} \frac{1}{\varepsilon_1^2}. \quad (119)$$

Assume furthermore that $v(\lambda)$ is slowly varying, and choose $\varepsilon_1 = \frac{1}{10\sqrt{\lambda}}$ and $\varepsilon_2 = \frac{1}{\sqrt{a\lambda}}$ as in (113), with $a < 1$ sufficiently small. Then we have

$$\lim_{\lambda \rightarrow \infty} \frac{N_{[\varepsilon_1(\lambda), \varepsilon_2(\lambda)]}^\pm(\lambda)}{\lambda^{n/2} v(\lambda)} = 0. \quad (120)$$

Proof. Let $I = [\varepsilon_1, \varepsilon_2]$. Close to the metric boundary $\mathcal{M}_{\varepsilon_1}^{\varepsilon_2} = I \times Z$ and

$$g = dx^2 + h(x), \quad (121)$$

where $h(x)$ is a one-parameter family of Riemannian metrics on the fixed $n - 1$ -dimensional manifold without boundary Z . It is sufficient to prove the proposition for the Neumann case. Let Q be the corresponding quadratic form and R the corresponding Rayleigh quotient, i.e.

$$Q(u) = \int_{I \times Z} |\nabla^g u|^2 d\mu_g, \quad R(u) = \frac{Q(u)}{\|u\|_{L^2(I \times Z, d\mu_g)}^2} \quad (122)$$

The idea is to control the Rayleigh quotient in terms of the one of a simpler metric. To this purpose let g_1 be the metric on $I \times Z$ obtained by freezing x to ε_1 , that is

$$g_1 = dx^2 + h(\varepsilon_1). \quad (123)$$

Fix a smooth measure dz on Z . Observe that

$$d\mu_g = e^{2\theta(x, z)} dx dz, \quad (124)$$

for some smooth function $\theta : I \times Z \rightarrow \mathbb{R}$. Notice that the mean curvature of the level sets of δ is $m = \text{Tr Hess}(\delta) = 2\partial_x \theta$. Therefore we have

$$-\frac{C}{x} \leq 2\partial_x \theta \leq 0, \quad (125)$$

for some constant $C > 0$ depending only on n . It follows that on $I \times Z$ it holds

$$\left(\frac{\varepsilon_1}{\varepsilon_2}\right)^C d\mu_{g_1} \leq d\mu_g \leq d\mu_{g_1}, \quad (126)$$

as measures. Inequality (126) will be used to estimate the behaviour of the measure in the Rayleigh quotient. For what concerns the behaviour of the norm of the gradient, let (z_1, \dots, z_{n-1}) be local coordinates on Z . One has that

$$g = dx^2 + \sum_{i, j=1}^{n-1} h_{ij}(x, z) dz_i dz_j. \quad (127)$$

The convexity assumption (i.e. $\text{Hess}(\delta) \leq 0$) amounts to the fact that inverse matrix $x \mapsto h^{ij}(x, z)$ is a non-decreasing family of positive quadratic forms. Hence

$$|\nabla^{g_1} u|^2 = |\partial_x u|^2 + \sum_{i,j=1}^{n-1} h^{ij}(x, z) \frac{\partial u}{\partial z_i} \frac{\partial u}{\partial z_j} \geq |\partial_x u|^2 + \sum_{i,j=1}^{n-1} h^{ij}(\varepsilon_1, z) \frac{\partial u}{\partial z_i} \frac{\partial u}{\partial z_j} = |\nabla^{g_1} u|^2. \quad (128)$$

It follows from (126) and (128) that, denoting with R_1 the Rayleigh quotient of the Riemannian manifold $(I \times Z, g_1)$, one has

$$R(u) \geq \left(\frac{\varepsilon_1}{\varepsilon_2}\right)^C R_1(u), \quad \forall u \in C^\infty(I \times Z). \quad (129)$$

By the minmax characterization of eigenvalues, it follows that

$$N_{(I \times Z, g)}^+(\lambda) \leq N_{(I \times Z, g_1)}^+ \left(\left(\frac{\varepsilon_2}{\varepsilon_1}\right)^C \lambda \right). \quad (130)$$

We stress that $(I \times Z, g_1)$ is the product of (I, dx^2) and (Z, h_1) , with $h_1 := h(\varepsilon_1)$. As such, it is a compact Riemannian manifold with convex (totally geodesic) boundary. Its sectional curvature is bounded by the one of the factor (Z, h_1) . By Gauss' equation there exists a constant C (depending only on the constants appearing in the condition (S) and hence not on the choice of $\varepsilon_1, \varepsilon_2$) such that

$$|\text{Sec}(I \times Z, g_1)| \leq |\text{Sec}(Z, h_1)| \leq \frac{C}{\varepsilon_1^2}. \quad (131)$$

Consider now the injectivity radius of $(I \times Z, g_1)$, which is clearly equal to the injectivity radius of (Z, h_1) , which is an embedded submanifold of (\mathcal{M}, g) with the induced metric. The injectivity radius of a submanifold of bounded second fundamental form in a Riemannian manifold of bounded sectional curvature and injectivity radius is bounded below in terms of the aforementioned quantities as stated in Lemma A.5 in the appendix. In particular there exists $C > 0$ not depending on the choice of $\varepsilon_1, \varepsilon_2$) such that

$$\text{inj}(I \times Z, g_1) = \text{inj}(Z, h_1) \geq C^{-1} \varepsilon_1. \quad (132)$$

We can now apply Theorem 2.5, yielding the existence of a constant $C > 0$, not depending on the choice of $\varepsilon_1, \varepsilon_2$, such that

$$N_{[\varepsilon_1, \varepsilon_2]}^+(\lambda) \leq C \text{vol}(I \times Z, g_1) \left(\left(\frac{\varepsilon_2}{\varepsilon_1}\right)^C \lambda \right)^{n/2}, \quad \forall \lambda > \left(\frac{\varepsilon_2}{\varepsilon_1}\right)^{-C} \frac{1}{\varepsilon_1^2}. \quad (133)$$

This proves the first part of the proposition, as $\text{vol}(I \times Z, g_1) = \text{vol}(\mathcal{Z}_{\varepsilon_1})(\varepsilon_2 - \varepsilon_1)$.

To prove the second part, from the definition $v(1/x^2) = \text{vol}(\mathcal{M}_x)$ we deduce that

$$\text{vol}(\mathcal{M}_x) = \int_x^\infty \text{vol}(\mathcal{Z}_x) dx \quad \Rightarrow \quad \text{vol}(\mathcal{Z}_{\varepsilon_1}) = \frac{v'(1/\varepsilon_1^2)}{2\varepsilon_1^3}. \quad (134)$$

Let now choose $\varepsilon_1 = \frac{1}{10\sqrt{\lambda}}$ and $\varepsilon_2 = \frac{1}{\sqrt{a\lambda}}$, for $a < 1$ and sufficiently small. Notice that if a is taken sufficiently small depending on the given value of C , then the condition

for the validity of (133) is verified for all λ . We have in this case, renaming the constants (which may now depend on a)

$$\frac{N_{[\varepsilon_1(\lambda), \varepsilon_2(\lambda)]}^+(\lambda)}{\lambda^{n/2}v(\lambda)} \leq C(a) \frac{\lambda v'(100\lambda)}{v(\lambda)}, \quad \forall \lambda > 0. \quad (135)$$

Since v is slowly varying the r.h.s. tends to zero (use the first part of Lemma 5.3). \square

The following straightforward result is an application of [6, Thm. 1.7.2 and Prop. 1.5.8]. See also [28, Thm. 2].

Lemma 5.3. *Let $v : \mathbb{R}_+ \rightarrow \mathbb{R}_+$ be a slowly varying function of class C^1 such that $\lambda \mapsto \lambda^a v'(\lambda)$ is monotone, for some $a \geq 0$. Then,*

$$\lim_{\lambda \rightarrow \infty} \frac{\lambda v'(\lambda)}{v(\lambda)} = 0. \quad (136)$$

Furthermore, if (136) holds, then v is slowly varying.

5.1 Metrics with prescribed Weyl's law

We prove the following converse to Theorem 5.1.

Theorem 5.4. *For any n -dimensional compact manifold N and non-decreasing slowly varying function $v : \mathbb{R}_+ \rightarrow \mathbb{R}_+$ there exists a Riemannian structure on N , singular along any prescribed submanifold S , such that*

$$\lim_{\lambda \rightarrow \infty} \frac{N(\lambda)}{\lambda^{n/2}v(\lambda)} = \frac{\omega_n}{(2\pi)^n}. \quad (137)$$

Proof. The idea is to build a non-complete structure on $N \setminus S$ with a warped-product structure near S , with respect to some function f . One has to carefully choose f in such a way that $\text{vol}(M_{1/\sqrt{\lambda}}) \sim v(\lambda)$ and Assumption (Σ) is satisfied. To this purpose one needs to control the asymptotic behaviour of the quantities $\lambda v''(\lambda)/v'(\lambda)$ and $\lambda v^{(3)}(\lambda)/v'(\lambda)$, which is in general impossible for slowly varying functions³. We tackle this problem resorting to the theory of regular variation, replacing v with a more tame slowly varying function with the prescribed asymptotic behavior as $\lambda \rightarrow \infty$.

More precisely, we refer to [6, Ch. 1, 3] for definition of the de Haan class Π , and the smooth de Haan class $S\Pi$, both strict subsets of slowly varying function. Firstly, by [20, Appendix B], any non-decreasing slowly varying function v is asymptotic to a de Haan function, which we still denote by $v \in \Pi$. Furthermore, by a smoothing result [6, Thm. 3.7.7], any de Haan function v is asymptotic to a smooth one, which we still denote with the same symbol $v \in S\Pi$. This implies that

$$\lim_{\lambda \rightarrow \infty} \frac{\lambda v^{(1+m)}(\lambda)}{v'(\lambda)} = (-1)^m m!, \quad \forall m \in \mathbb{N}. \quad (138)$$

³Observe that these limits exists for all examples of monotone slowly varying function given at the beginning of this section. An example of strictly monotone slowly varying function for which the quantity $\lambda v''(\lambda)/v(\lambda)$ does not have a limit is $v'(\lambda) = 2 \log \lambda + \sin \log \lambda$.

Moreover, it follows from the proof of [6, Thm. 3.7.7] that $v'(\lambda) > 0$ for sufficiently large values of λ . Thus, we will henceforth assume that v itself is smooth, strictly increasing, and satisfies (138).

We proceed now with the construction in the case in which S is a submanifold of co-dimension > 1 or is one-sided. The case of a two-sided hypersurfaces follows from a similar argument. Choose a tubular neighborhood $U \subset N$ of S such that $U \setminus S = (0, 2) \times F$, where F is a fixed hypersurface without boundary (clearly this is possible for any smooth embedded submanifold S of co-dimension > 1). Choose some fixed metric \hat{g} on F , and set on U :

$$g = dx^2 + f^2 \hat{g}, \quad (139)$$

where $f : (0, 2) \rightarrow \mathbb{R}_+$ is a positive smooth function to be chosen later and meant to explode as x tends to 0. Extend g to a smooth Riemannian metric on the whole $\mathcal{M} := N \setminus S$, by preserving (139) on the neighborhood $(0, 1) \times F$.

By construction (\mathcal{M}, g) has compact metric completion, and has regular metric boundary. Furthermore $\delta = x$ for $x \in (0, 1)$. In particular the level sets of δ close to the metric boundary are diffeomorphic to two copies of F . We now define f in such a way that $\text{vol}(M_{1/\sqrt{\lambda}}) \sim v(\lambda)$, setting

$$f(x)^{n-1} = \frac{2}{\text{vol}(F, \hat{g})} \frac{v'(1/x^2)}{x^3}, \quad x \in (0, 1). \quad (140)$$

Since v is strictly increasing, $f > 0$ and its only singularity is at $x = 0$.

Let us verify (\mathcal{M}, g) satisfies Assumption (Σ) . The projection on the first factor $\pi : (0, 1) \times_{f^2} F \rightarrow (0, 1)$ of the warped product (139) is a Riemannian submersion with leaves (F, \hat{g}) . Using O'Neill formulas [5, 9.29, 9.104], the sectional curvatures are:

$$K(U, V) = \frac{1}{f^2} \hat{K}(U, V) - \left(\frac{f'}{f} \right)^2, \quad (141)$$

$$K(X, U) = -\frac{f''}{f}, \quad (142)$$

$$K(X, Y) = 0. \quad (143)$$

Here, U, V are orthonormal vectors tangent to the fibers F , X, Y are unit vectors tangent to the base $(-1, 1)$, and \hat{K} is the sectional curvature of (F, \hat{g}) . Finally, the hypersurfaces $\{\delta = |x|\}$ have as their second fundamental form

$$\text{Hess}(\delta)(U, V) = \frac{f'}{f} g(U, V). \quad (144)$$

Notice that, since $v \in S\Pi$, we have that $\lambda v'(\lambda)$ is slowly varying at infinity. It follows that $f(x) \rightarrow +\infty$ as $x \rightarrow 0$. It is then clear that the quantities controlling the behavior of the geometric invariants of g close to the metric boundary (i.e. as $x \rightarrow 0$) are f'/f and f''/f . Thanks to the fact that v is a de Haan function, we are able to compute their asymptotics. By (138), $h_m(x) \rightarrow (-1)^m m!$ as $|x| \rightarrow 0$, where

$$h_m(x) := \frac{v^{(m+1)}(1/x^2)}{x^2 v'(1/x^2)}, \quad m = 1, 2, \dots \quad (145)$$

Using (140), we have hence, as $x \rightarrow 0$,

$$\frac{f'(x)}{f(x)} = -\frac{3 + 2h_1(x)}{(n-1)x} \sim -\frac{1}{(n-1)x}, \quad (146)$$

$$\frac{f''(x)}{f(x)} = \frac{3n + 6 - 4(n-2)h_1(x)^2 + 4(n-1)h_2(x) + 6(n+1)h_1(x)}{(n-1)^2x^2} \sim \frac{n}{(n-1)^2x^2}. \quad (147)$$

We deduce that for all $\varepsilon < \varepsilon_0$ with ε_0 sufficiently small, the Assumption (Σ) is verified. We conclude by applying Theorem 5.1 to (\mathcal{M}, g) . \square

Remark 5.1. We mention in passing that the Laplace-Beltrami operator of the structure built in the proof of Theorem 5.4, with domain $C_c^\infty(\mathcal{M})$, is essentially self-adjoint in $L^2(\mathcal{M}, d\mu_g)$. Indeed, as a consequence of the curvature estimates obtained in the above proof, one has $\Delta x = \frac{(n-1)f'}{f}$, and hence

$$V_{\text{eff}} := \left(\frac{\Delta x}{2}\right)^2 + \left(\frac{\Delta x}{2}\right)' \sim \frac{3}{4x^2}, \quad x \rightarrow 0. \quad (148)$$

where the prime denotes the derivative with respect to the inward pointing normal to the fibers F . In particular, it must hold that, for sufficiently small x

$$V_{\text{eff}} \geq \frac{3}{4x^2} \left(1 - \frac{1}{\log x^{-1}}\right). \quad (149)$$

This allows to apply the essential-self adjointness criterion of [38], combined with the improvement of the constant obtained in [34]. We omit the details.

6 Concentration of eigenfunctions

Under the assumptions of Theorem 4.3, it holds that $N(\lambda) \asymp \lambda^{n/2} \text{vol}(\mathcal{M}_{1/\sqrt{\lambda}})$. Recall that $f \asymp g$ means that the ratio f/g is uniformly bounded above and below by positive constants for λ large enough. In this section, we show that under the additional assumption $\text{vol}(\mathcal{M}) = \infty$, then the eigenfunctions concentrate on the metric boundary of \mathcal{M} .

We recall that a subset $S \subseteq \mathbb{N}$ has density $a \in [0, 1]$ if

$$\lim_{\ell \rightarrow \infty} \frac{1}{\ell} \sum_{k=0}^{\ell-1} \mathbb{1}_S(k) = a. \quad (150)$$

Theorem 6.1. *Let \mathcal{M} be a n -dimensional non-complete Riemannian manifold such that the Laplace-Beltrami operator Δ has discrete spectrum. Assume that*

$$\lim_{\lambda \rightarrow \infty} \frac{N(\lambda)}{\lambda^{n/2}} = \infty. \quad (151)$$

Let $0 \leq \lambda_1 \leq \lambda_2 \leq \dots$ be the eigenvalues of $-\Delta$, and, for all $i \in \mathbb{N}$, denote by ϕ_i the normalized eigenfunction associated with the eigenvalue λ_i . Then, there exists a density one subset $S \subseteq \mathbb{N}$ such that for any compact U it holds

$$\lim_{\substack{i \rightarrow \infty \\ i \in S}} \int_U |\phi_i(x)|^2 d\mu_g(x) = 0. \quad (152)$$

Proof. Fix a compact set U . Let p_Δ denote the heat kernel of Δ . Let $a_i(U) := \int_U |\phi_i(x)|^2 d\mu_g(x)$. Since the heat kernel is local, we have

$$t^{n/2} \sum_{i=1}^{\infty} e^{-t\lambda_i} a_i(U) = t^{n/2} \int_U p_\Delta(t, x, x) d\mu_g(x) \sim c, \quad t \rightarrow 0, \quad (153)$$

for some constant $c > 0$. By the standard Karamata theorem it holds

$$\sum_{\lambda_i \leq \lambda} a_i(U) \sim \frac{c}{\Gamma(n/2 + 1)} \lambda^{n/2}, \quad \lambda \rightarrow \infty. \quad (154)$$

By our assumption on $N(\lambda)$ it holds then

$$\lim_{\ell \rightarrow \infty} \frac{1}{\ell} \sum_{i=1}^{\ell-1} a_i(U) = 0. \quad (155)$$

By [36, Lemma 6.2], the above statement is equivalent to the existence of a density one subset $S_U \subseteq \mathbb{N}$ such that

$$\lim_{\substack{i \rightarrow \infty \\ i \in S_U}} a_i(U) = 0. \quad (156)$$

The subset $S_U \subset \mathbb{N}$ *a priori* depends on the choice of U but we next build a subset S having the same property and which does not depend on U , as claimed in the statement. The proof uses ideas similar to those in the proof of [36, Lemma 6.2] and [13, Sec. 5].

Let $\{U_m\}_{m \in \mathbb{N}}$ be an exhaustion of \mathcal{M} by compact subsets, that is each U_m is compact, $U_{m+1} \supset U_m$, and $U_m \rightarrow \mathcal{M}$ as $m \rightarrow \infty$. Let $S_m \subset \mathbb{N}$ a density one subset built as above, such that

$$\lim_{\substack{i \rightarrow \infty \\ i \in S_m}} a_i(U_m) = 0. \quad (157)$$

Without loss of generality, we can assume that $S_{m+1} \subseteq S_m$ (if this is not the case, we take in place of S_m the set $\tilde{S}_m = \bigcap_{i \leq m} S_i$. Indeed \tilde{S}_m is a density-one subset of \mathbb{N} with the required properties, and such that (157) holds).

By the density one property, there exists $i_1 < i_2 < \dots$ such that

$$\frac{1}{\ell} \sum_{k=0}^{\ell-1} \mathbb{1}_{S_m}(k) \geq 1 - \frac{1}{m}, \quad \forall \ell \geq i_{m-1}. \quad (158)$$

Then, the required set S can be taken as

$$S := \bigcup_{m=1}^{\infty} S_m \cap [i_m, i_{m+1}), \quad (159)$$

Indeed, if $i_m \leq n < i_{m+1}$ we have

$$\frac{1}{\ell} \sum_{k=0}^{\ell-1} \mathbb{1}_S(k) \geq \frac{1}{\ell} \sum_{k=0}^{\ell-1} \mathbb{1}_{S_m}(k) \geq 1 - \frac{1}{m}, \quad (160)$$

yielding that S has density one.

Notice that, by construction since $S_{m+1} \subseteq S_m$, we have that $S \cap [i_m, \infty) \subseteq S_m$. Therefore for all $m > 0$ we have

$$\lim_{\substack{i \rightarrow \infty \\ i \in S}} a_i(U_m) = 0. \quad (161)$$

We conclude the proof by noticing that any compact set \bar{U} is contained in some $U_{\bar{m}}$, and we have $a_i(\bar{U}) \leq a_i(U_{\bar{m}})$ for all $i \in \mathbb{N}$. \square

7 Strongly regular ARS

We now apply our results to a class of structures where the metric boundary can be locally described as the singular region of a Riemannian metric. This class is modeled on almost-Riemannian structures, introduced in [2]. We provide here a direct and local definition, which is sufficient for our purposes. We refer the reader to [38, Sec. 7] for a self-contained presentation closer to our approach.

Let N be a smooth, connected n -dimensional manifold, and let $\mathcal{Z} \subset N$ be a smooth embedded hypersurface \mathcal{Z} . We assume to be given a metric g , which is Riemannian on $N \setminus \mathcal{Z}$ and such that for all $p \in \mathcal{Z}$ there exist local coordinates $(x, z) \in \mathbb{R} \times \mathbb{R}^{n-1}$ and smooth vector fields

$$X_0 = \partial_x, \quad X_i = \sum_{j=1}^{n-1} a_{ij}(x, z) \partial_{z_j}, \quad (162)$$

which are orthonormal for g outside of \mathcal{Z} , and $\det a_{ij}(x, z) = 0$ if and only if $x = 0$.

Furthermore, we ask that there exists an $m \in \mathbb{N}$ such that

$$a_{ij}(x, z) = x^m \hat{a}_{ij}(x, z), \quad \det \hat{a}_{ij} \neq 0. \quad (163)$$

In this case, on each local chart, we have

$$X_0 = \partial_x, \quad X_i = x^m \hat{X}_i = x^m \sum_{j=1}^{n-1} \hat{a}_{ij} \partial_{z_j}, \quad (164)$$

where $X_0, \hat{X}_1, \dots, \hat{X}_n$ have maximal rank also on the singular region. In particular we can introduce the regularized Riemannian structure in a neighborhood of \mathcal{Z} such that $\hat{X}_0 = X_0, \hat{X}_1, \dots, \hat{X}_n$ are a smooth orthonormal frame. We denote with a hat all the quantities relative to this structure. In particular, the *regularized measure* $\hat{\sigma}(\mathcal{Z})$ of \mathcal{Z} is well defined, as the induced measure on \mathcal{Z} of the regular Riemannian structure.

Definition 7.1. A singular Riemannian structure on an n -dimensional manifold N satisfying the above condition is called an m -strongly regular ARS, where m is the integer defined in (163).

The non-complete Riemannian manifold $\mathcal{M} = N \setminus \mathcal{Z}$ has metric boundary given by at most two copies of \mathcal{Z} (depending whether the latter is one or two-sided). Finally, in the above local coordinates, and close to \mathcal{Z} , we have $\delta(x, z) = |x|$. It follows that any strongly regular ARS has regular metric boundary.

Remark 7.1. As a consequence of the theory developed in [38], the Laplace-Beltrami of a strongly regular ARS is essentially self-adjoint in $L^2(N \setminus \mathcal{Z})$. The same result holds more generally for *regular structures*, introduced in [38], that is, when the condition (163) is replaced by the weaker one

$$\det a_{ij}(x, z) = x^k \phi(x, z), \quad \phi(x, z) \neq 0. \quad (165)$$

Indeed, any strongly regular structure is regular, for $k = m(n - 1)$.

7.1 Curvature bounds

We now discuss the relevant curvature bounds for strongly regular ARS.

Proposition 7.2. *For any m -strongly regular ARS on a compact n -dimensional manifold, there exists $\varepsilon_0, C > 0$ such that, for all planes Σ , one has*

$$|\text{Sec}(\Sigma)| \leq \frac{C}{\delta^2}, \quad -\frac{C}{\delta} \leq \text{Hess}(\delta) < 0, \quad (166)$$

whenever $\delta \leq \varepsilon_0$. Furthermore, as $\varepsilon \rightarrow 0$, we have

$$\text{vol}(\mathcal{M}_\varepsilon^\infty) \sim 2\hat{\sigma}(\mathcal{Z}) \begin{cases} \varepsilon^{-(m(n-1)-1)} & m(n-1) > 1, \\ \log \varepsilon^{-1} & m(n-1) = 1. \end{cases} \quad (167)$$

Proof. To compute curvature-like quantities, we adopt the following modified Einstein convention. Latin indices run from $1, \dots, n-1$, and repeated indices are summed on that range. The index 0 is reserved for the variable x , e.g. $\partial_0 = \partial_x$. The non vanishing structural functions are given by

$$[X_0, X_i] = c_{0i}^\ell X_\ell, \quad [X_i, X_j] = c_{ij}^\ell X_\ell. \quad (168)$$

Koszul formula for the Levi-Civita connection in terms of orthonormal frames yields

$$\nabla_i X_j = \Gamma_{ij}^\ell X_\ell + \gamma_{ij} X_0, \quad \nabla_0 X_i = \delta_{i\ell} X_\ell, \quad \nabla_i X_0 = -\gamma_{i\ell} X_\ell, \quad (169)$$

$$\delta_{i\ell} = \frac{1}{2}(c_{0i}^\ell - c_{0\ell}^i), \quad \gamma_{i\ell} = \frac{1}{2}(c_{0\ell}^i + c_{0i}^\ell), \quad \Gamma_{ij}^\ell = \frac{1}{2}(c_{ij}^\ell + c_{\ell j}^i + c_{\ell i}^j). \quad (170)$$

Notice that $\delta = -\delta^*$, $\gamma = \gamma^*$, while $\Gamma_{ij}^\ell = -\Gamma_{i\ell}^j$. From the definition of curvature

$$R(X, Y, Z, W) = g(\nabla_X \nabla_Y Z - \nabla_Y \nabla_X Z - \nabla_{[X, Y]} Z, W), \quad (171)$$

we deduce the following formulas for the Riemann tensor

$$R(X_i, X_j, X_k, X_\ell) = \partial_i \Gamma_{jk}^\ell + \Gamma_{jk}^s \Gamma_{is}^\ell - \gamma_{jk} \gamma_{i\ell} - \partial_j \Gamma_{ik}^\ell - \Gamma_{ij}^s \Gamma_{ks}^\ell \quad (172)$$

$$+ \gamma_{ik} \gamma_{j\ell} - c_{ij}^s \Gamma_{sk}^\ell, \quad (173)$$

$$R(X_i, X_j, X_k, X_0) = \Gamma_{jk}^\ell \gamma_{i\ell} + \partial_i \gamma_{jk} - \Gamma_{ik}^\ell \gamma_{j\ell} - \partial_j \gamma_{ik} - c_{ij}^s \gamma_{sk}, \quad (174)$$

$$R(X_0, X_i, X_j, X_0) = \partial_0 \gamma_{ij} + \gamma_{i\ell} \delta_{\ell j} + \gamma_{j\ell} \delta_{\ell i} - \gamma_{i\ell} \gamma_{\ell j}, \quad (175)$$

In particular $\text{Sec}(X \wedge Y) = R(X, Y, Y, X)$ for any pair of unit orthogonal vectors X, Y . Furthermore, since $d_\partial = |x|$, we have

$$\text{Hess}(\delta)(X_i, X_j) = -\gamma_{ij}. \quad (176)$$

In terms of the matrix a , the structural functions read

$$c_{0i}^\ell = a_{\ell s}^{-1} \partial_0 a_{si}, \quad c_{ij}^\ell = (a_{ri} \partial_r a_{sj} - a_{jr} \partial_r a_{si}) a_{s\ell}^{-1}. \quad (177)$$

Using (177) one obtains

$$c_{0i}^\ell = \frac{m}{x} \mathbb{1}_{i\ell} + \hat{c}_{0i}^\ell, \quad c_{ij}^\ell = x^m \hat{c}_{ij}^\ell, \quad (178)$$

which implies

$$\delta_{ij} = \hat{\delta}_{ij}, \quad \gamma_{ij} = \frac{m}{x} \mathbb{1}_{ij} + \hat{\gamma}_{ij}, \quad \Gamma_{ij}^\ell = x^m \hat{\Gamma}_{ij}^\ell. \quad (179)$$

From (173)-(175) we obtain

$$R(X_i, X_j, X_k, X_\ell) = -\frac{m^2}{x^2} (\mathbb{1}_{jk} \mathbb{1}_{i\ell} - \mathbb{1}_{ik} \mathbb{1}_{j\ell}) + O\left(\frac{1}{x}\right), \quad (180)$$

$$R(X_i, X_j, X_k, X_0) = O(1), \quad (181)$$

$$R(X_0, X_i, X_j, X_0) = -\frac{m(m+1)}{x^2} \mathbb{1}_{ij} + O\left(\frac{1}{x}\right). \quad (182)$$

and

$$\text{Hess}(d_\partial)(X_i, X_j) = -\frac{m}{x} \mathbb{1}_{ij} + O(1). \quad (183)$$

To compute the volume asymptotics, assume without loss of generality that \mathcal{Z} is contained in a single chart. Then we have, $\text{vol}(\mathcal{M}_\varepsilon^\infty) \sim \text{vol}(\mathcal{M}_\varepsilon^{\varepsilon_0})$, and

$$\text{vol}(\mathcal{M}_\varepsilon^{\varepsilon_0}) = \int_{\varepsilon \leq |x| \leq \varepsilon_0} dx \int_{\mathcal{Z}} \sqrt{\det(aa^*)}(x, z) dz \quad (184)$$

$$= \int_{\varepsilon \leq |x| \leq \varepsilon_0} \frac{1}{x^{m(n-1)}} dx \int_{\mathcal{Z}} \sqrt{\det(\hat{a}\hat{a}^*)}(x, z) dz \quad (185)$$

$$= \int_{\varepsilon \leq |x| \leq \varepsilon_0} \frac{1}{x^{m(n-1)}} dx \left(\int_{\mathcal{Z}} \sqrt{\det(\hat{a}\hat{a}^*)}(0, z) dz \right) (1 + O(\varepsilon)) \quad (186)$$

$$= 2(1 + O(\varepsilon)) \hat{\sigma}(\mathcal{Z}) \int_\varepsilon^{\varepsilon_0} \frac{1}{x^{m(n-1)}} dx, \quad (187)$$

from which the result follows. \square

The next example shows that the results of Proposition 7.2 do not hold without the strongly regular condition (163). In particular, one can have ARS where all geometric quantities have an arbitrarily fast polynomial explosion to $\pm\infty$.

Example 7.1 (Worst case curvature explosion). The example is in dimension $n = 3$, then it is sufficient to take the metric product with an Euclidean space of the appropriate dimension to obtain the analogue example in dimension n . We stress that the forthcoming example respects the k -regular condition (165).

Let $k \geq 1$, and consider the structure defined locally in coordinates $(x, z) \in \mathbb{R} \times \mathbb{R}^2$ by the vector fields

$$X_0 = \partial_x, \quad X_1 = \partial_{z_1} + x\partial_{z_2}, \quad X_2 = x^k\partial_{z_2}. \quad (188)$$

In other words, $X_i = a_{ji}\partial_{z_i}$, for $i = 1, 2$, with

$$a = \begin{pmatrix} 1 & 0 \\ x & x^k \end{pmatrix}. \quad (189)$$

The most singular terms in the curvature arise all from the first equation of (177). In particular letting $C_{il} = c_{0i}^l$, we have

$$C = (a^{-1}\partial_0 a)^* = \begin{pmatrix} 0 & \frac{1}{x^k} \\ 0 & \frac{k}{x} \end{pmatrix}. \quad (190)$$

It follows that

$$\delta = \frac{1}{2}(C - C^*) = \begin{pmatrix} 0 & \frac{1}{2x^k} \\ -\frac{1}{2x^k} & 0 \end{pmatrix}, \quad \gamma = \frac{1}{2}(C + C^*) = \begin{pmatrix} 0 & \frac{1}{2x^k} \\ \frac{1}{2x^k} & \frac{k}{x} \end{pmatrix}. \quad (191)$$

Notice that, rewriting (175) in this notation, we obtain, for $i = 1, 2$,

$$\text{Sec}(X_0 \wedge X_i) = (\partial_0 \gamma + 2\gamma\delta - \gamma^2)_{ii} = \text{diag} \left(-\frac{3}{4x^{2k}}, \frac{1}{4x^{2k}} - \frac{k(k+1)}{x^2} \right), \quad (192)$$

and, for $i, j = 1, 2$,

$$\text{Hess}(d_\partial)(X_i, X_j) = -\frac{1}{2} \begin{pmatrix} 0 & \frac{1}{2x^k} \\ \frac{1}{2x^k} & \frac{k}{x} \end{pmatrix}, \quad (193)$$

whose eigenvalues obey $h_\pm = \pm \frac{1}{2x^k}(1 + o(1))$ as $x \rightarrow 0$.

7.2 Weyl asymptotics for ARS

We now apply the theory developed in the previous sections to ARS. We recall that the notation $f \asymp g$ means that f/g has finite and positive lim sup and lim inf.

Theorem 7.3 (Weyl asymptotics for ARS). *Consider the Laplace-Beltrami operator of an m -strongly regular ARS on an n -dimensional compact manifold. Then, with the exception of the case $n = 2$ and $m = 1$, we have*

$$N(\lambda) \asymp \lambda^{(n-1)(m+1)/2}, \quad \lambda \rightarrow +\infty. \quad (194)$$

In the special case $n = 2$ and $m = 1$, we have

$$\lim_{\lambda \rightarrow +\infty} \frac{N(\lambda)}{\lambda \log \lambda} = \frac{|\hat{\sigma}(\mathcal{Z})|}{4\pi}. \quad (195)$$

Proof. As we discussed at the beginning of this section, a strongly regular ARS has regular metric boundary. Furthermore, by Proposition 7.2, it respects all assumptions of Theorem 4.3. Notice that, since the boundaries of the truncations $\mathcal{M}_\varepsilon^\infty$ are *strictly* convex, we applied Proposition 3.2, to avoid a direct estimate of the injectivity radius (see Remark 1.1). The volume function $v(\lambda) = \text{vol}(\mathcal{M}_{1/\sqrt{\lambda}}^\infty)$ can be easily recovered from Proposition 7.2:

$$v(\lambda) \sim 2\hat{\sigma}(\mathcal{Z}) \begin{cases} \lambda^{(m(n-1)-1)/2} & m(n-1) > 1, \\ \log \lambda & m(n-1) = 1. \end{cases} \quad (196)$$

In the first case the result follows from Theorem 4.3. In the second case, $v(\lambda)$ is slowly varying, and we can apply Theorem 5.1. \square

A Auxiliary geometric estimates

On the simply connected n -dimensional Riemannian space form M_K of curvature $K \in \mathbb{R}$, the heat kernel depends only on t and on the distance $r = d(x, y)$, hence with a slight abuse of notation we denote it with $p_K(t, r)$. Here and below $r \in [0, +\infty)$ if $K \leq 0$, and $r \in [0, \pi/\sqrt{K}]$ if $K > 0$.

Lemma A.1 (Uniform heat kernel for model spaces). *For all $T > 0$ there exists a constant $C > 0$, depending only on n and T , such that*

$$|(4\pi t)^{n/2} p_K(t, 0) - 1| \leq C|K|t, \quad \forall t \leq T/|K|. \quad (197)$$

Proof. If $K = 0$, the estimate is trivially verified. Let us consider $K \neq 0$. For a Riemannian metric G and $\alpha > 0$, let $g_\alpha := \alpha^2 g$. Then, $\text{Sec}(g_\alpha) = \alpha^{-2} \text{Sec}(g)$, and $p_{g_\alpha}(t, x, y) = \alpha^{-d} p_g(t/\alpha^2, x, y)$. This immediately implies

$$(4\pi t)^{n/2} p_K(t, r) = (4\pi t|K|)^{n/2} p_{\pm 1}(t|K|, r\sqrt{|K|}), \quad (198)$$

where ± 1 is the sign of K . Moreover, by the Minakshisundaram-Pleijel asymptotics⁴, we deduce that for all $T > 0$ there exist a constant $C > 0$ such that

$$|(4\pi t)^{n/2} p_{\pm 1}(t, 0) - 1| \leq Ct, \quad \forall t \leq T, \quad (199)$$

where C depends only on n and T . This and (198) prove the statement. \square

Lemma A.2. *Let $K \geq 0$, and let $B_K(r)$ be the ball of radius $r \leq \pi/\sqrt{K}$ on the simply connected space form with constant curvature equal to K and dimension n . Then, there exists a constant $C > 0$, depending only on the dimension, such that*

$$\text{vol}(B_K(r)) \geq Cr^n, \quad \forall r \leq \pi/\sqrt{K}. \quad (200)$$

⁴We refer to the following simplified statement, valid for any complete n -dimensional Riemannian manifold: for all $T > 0$ and $x \in M$ there exists $C > 0$ such that $|(4\pi t)^{n/2} p(t, x, x) - 1| \leq Ct$, for all $t \in (0, T]$. For a proof in the compact case see e.g. [39, Prop. 3.23]. The extension to the non compact case is done via a localization argument (as in (26)) and Varadhan's formula.

Proof. By Bishop-Gromov, and since $K \geq 0$, the function

$$r \mapsto \text{vol}(B_K(r))/\text{vol}(B_0(r)) \quad (201)$$

is non-increasing. Hence, by the same rescaling argument used to prove Lemma A.1,

$$\frac{\text{vol}(B_K(r))}{\text{vol}(B_0(r))} = \frac{\text{vol}(B_1(r\sqrt{K}))}{\sqrt{K}^n \text{vol}(B_0(r))} = \frac{\text{vol}(B_1(r\sqrt{K}))}{\text{vol}(B_0(r\sqrt{K}))} \geq \frac{\text{vol}(B_1(\pi))}{\text{vol}(B_0(\pi))}. \quad (202)$$

To conclude the proof it suffices to observe that $\text{vol}(B_0(r)) = r^n \text{vol}(B_0(1))$. In particular, $C = \text{vol}(B_1(\pi))/\pi^n$. \square

In the next Lemma we show that for any ball $B_x(r)$ there always exists a spherical sector which points away from the boundary and whose size does not depend on the point. This yields a uniform lower bound to the measure of sufficiently small balls.

Lemma A.3 (Uniform volume lower bound for manifolds with boundary). *Let (M, g) be a complete n -dimensional Riemannian manifold with boundary. Let $H \geq 0$ such that $-H \leq \text{Hess}(d_\partial)$ for $d_\partial < \text{inj}_{\partial M}$. Let*

$$r_0 = \min \left\{ \text{inj}_M, \frac{\text{inj}_{\partial M}}{2}, \frac{1}{H} \right\}. \quad (203)$$

Then for any $x \in M$ and $r \leq r_0$ there exists an open set $S_x(r) \subset B_x(r)$ such that

- if $B_x(r)$ does not intersect ∂M , then $S_x(r) = B_x(r)$;
- if $B_x(r)$ intersects ∂M , then the closest point of $S_x(r)$ to ∂M is x .

Let, moreover, $K \geq 0$ be such that $\text{Sec}(g) \leq K$ on $S_x(r)$. Then, there exists a constant $C \in (0, 1/2)$, depending only on n , such that

$$\text{vol}(B_x(r)) \geq \text{vol}(S_x(r)) \geq C \text{vol}(B_K(r)), \quad \forall r \leq r_0. \quad (204)$$

Proof. Fix $r \leq r_0$. If $d_\partial(x) > r$, the ball does not intersect the boundary, and we set $S_x(r) = B_x(r)$. By the upper bound on Sec and since the balls lie within the injectivity radius from their center, we have that their volumes are bounded from below by the volume of the metric ball with the same radius on the space form with constant curvature equal to K :

$$\text{vol}(B_x(r)) \geq \text{vol}(B_K(r)). \quad (205)$$

If $d_\partial(x) \leq r$, the ball hits ∂M . The condition $r < \text{inj}_{\partial M}/2$ implies that $B_x(r)$ lies in the region where d_∂ is smooth and $-H \leq \text{Hess}(d_\partial)$. Consider a length parametrized geodesic γ emanating from x , and directed towards the direction where d_∂ increases, that is with $\theta \in [-\pi/2, \pi/2]$, where $\cos \theta = g(\dot{\gamma}, \nabla d_\partial)$. Hence

$$d_\partial(\gamma(t)) \geq -\frac{H}{2} \sin^2(\theta)t^2 + \cos(\theta)t + d_\partial(x), \quad \forall t \leq r. \quad (206)$$

Therefore, minimizing geodesics emanating from x and with length smaller than r do not cross ∂M provided that, e.g.,

$$\cos \theta \geq \frac{Hr}{2}. \quad (207)$$

Thanks to the assumption $r \leq 1/H$ the above inequality holds if $|\theta| < \pi/3$. Let $S_x(r) \subset B_x(r)$ be the corresponding spherical sector of radius r . By construction, x is the closest point to ∂M . Since $r \leq r_0 \leq \text{inj}(x)$, we can fix normal polar coordinates $(s, \Omega) \in [0, r_0] \times \mathbb{S}^{n-1}$ at x . Therefore

$$\text{vol}(B_x(r)) \geq \text{vol}(S_x(r)) = \int_{\bar{S}_x(r)} s^{n-1} A(s, \Omega) ds d\Omega, \quad (208)$$

where $\bar{S}(r)$ is the Euclidean spherical sector corresponding to $S_x(r)$ in these coordinates, and $s^{n-1} A(s, \Omega)$ is the Jacobian determinant of the exponential map with base x . By standard comparison arguments, the assumption $\text{Sec}(g) \leq K$ yields $A(s, \Omega) \geq A_K(s)$, where the latter is the corresponding object on the n -dimensional space form with constant curvature equal to K . Hence

$$\text{vol}(S_x(r)) \geq \int_{\bar{S}(r)} s^{n-1} A_K(s) ds d\Omega. \quad (209)$$

Without loss of generality we can fix coordinates $(\theta, \varphi) \in (-\pi/2, \pi/2) \times \mathbb{S}^{n-2}$ such that $\bar{S}(r) = \{|\theta| < \pi/3, s < r\}$. In these coordinates $d\Omega = \sin(\theta)^{n-2} d\theta d\varphi$, where $d\varphi$ is the standard measure on \mathbb{S}^{n-2} . Therefore

$$\text{vol}(S_x(r)) \geq \int_0^r s^{n-1} A_K(s) ds \int_0^{\pi/3} d\theta \sin(\theta)^{n-2} \text{vol}(\mathbb{S}^{n-2}) = C \text{vol}(B_K(r)). \quad (210)$$

Simple symmetry considerations imply that $C \in (0, 1/2)$. \square

Lemma A.4 (Li-Yau inequality). *Let (M, g) be a complete n -dimensional Riemannian manifold with convex boundary, and $\text{Ric}(g) \geq -K(n-1)$, for some $K \geq 0$. Then there exist constants $C_1, C_2, C_3 > 0$, depending only on n , such that*

$$p^\pm(t, x, y) \leq \frac{C_1}{\sqrt{\text{vol}(B_x(\sqrt{t}))\text{vol}(B_y(\sqrt{t}))}} e^{C_2 K t - C_3 \frac{d^2(x, y)}{4t}}, \quad \forall (t, x, y) \in \mathbb{R}_+ \times M \times M. \quad (211)$$

Furthermore, let $H \geq 0$ such that $-H \leq \text{Hess}(d_\partial)$ for $d_\partial < \text{inj}_{\partial M}$, let $K \geq 0$ such that $\text{Sec}(M) \leq K$, and let

$$\sqrt{t_0} = \min \left\{ \text{inj}_M, \frac{\text{inj}_{\partial M}}{2}, \frac{1}{H}, \frac{\pi}{\sqrt{K}} \right\}. \quad (212)$$

Then, there exists a constant $C_4 > 0$, depending only on n , such that

$$(4\pi t)^{n/2} p^\pm(t, x, y) \leq C_4 e^{-C_3 \frac{d^2(x, y)}{4t}}, \quad \forall (t, x, y) \in (0, t_0) \times M \times M. \quad (213)$$

Proof. The Dirichlet heat kernel is dominated from above by the Neumann heat kernel. In this case the first inequality is [29, Thm. 3.2], where the parameters ε and α are fixed in the allowed ranges.

To prove the second part of the theorem, it suffices to uniformly bound from below the volumes of the balls appearing at the denominator of (211). Since $\sqrt{t_0}$ is smaller than the r_0 appearing in Lemma A.3, the latter implies the existence of a constant $C > 0$, depending only on n , such that $\text{vol}(B_z(\sqrt{t})) \geq C \text{vol}(B_K(\sqrt{t}))$ for all $z \in M$. Then, to complete the proof, it suffices to observe that the bound $\sqrt{t_0} \leq \pi/\sqrt{K}$ implies that $\text{vol}(B_K(\sqrt{t})) \geq C_1 t^{n/2}$ for some dimensional constant $C_1 > 0$. This follows by elementary computations, as done in the proof of Lemma A.2. \square

The following theorem was mentioned in [3, p. 69] for metric spaces with curvature bounded above. Quite surprisingly, we were not able to find a proof or a statement it in the literature for the Riemannian case.

Lemma A.5. *Let N be a closed Riemannian submanifold of a Riemannian manifold (M, g) , with bounded second fundamental form $|II| \leq H$. Assume also that $\text{Sec}(M, g) \leq K$. Letting h be the induced metric on N inherited from g , we have*

$$\text{inj}(N, h) \geq \min \left\{ \frac{\pi}{\sqrt{K + H^2}}, \frac{\pi}{2\sqrt{K}}, \text{inj}(M, g) \right\}, \quad (214)$$

with the usual convention that $\pi/\sqrt{K} = \infty$ if $K \leq 0$.

Proof. By Gauss' equation, for all $X, Y, Z, W \in TN$ we have

$$R^g(X, Y, Z, W) = R^h(X, Y, Z, W) + II(X, Z)II(Y, W) - II(Y, Z)II(X, W). \quad (215)$$

It follows that $\text{Sec}(N, h) \leq K + H^2$. By Klingenberg's Lemma

$$\text{inj}(N, h) \geq \min \left\{ \frac{\pi}{\sqrt{K + H^2}}, \frac{\ell(\gamma)}{2} \right\}, \quad (216)$$

where $\ell(\gamma)$ is length the shortest non-trivial closed geodesic in (N, h) . Let γ be such a geodesic, parametrized with unit speed. Its curvature in (M, g) is bounded by

$$|\nabla_{\dot{\gamma}}^g \dot{\gamma}| = |II(\dot{\gamma}, \dot{\gamma})| \leq H. \quad (217)$$

Hence its length cannot be too short, provided that some conditions are met. Assume that $\ell(\gamma) \leq \min\{2\text{inj}(M, g), \pi/\sqrt{K}\}$. In this case, γ lies in a ball B_R of radius $R \leq \frac{\pi}{2\sqrt{K}}$ and within the injectivity radius of its center. By [3, Thm. 4.3], B_R is an R_K domain in the sense of Alexandrov (i.e. a domain $U \subset M$ such that for any pair of points in U there exists a geodesic of length $< \pi/\sqrt{K}$, it varies continuously with the endpoints, and minimizes the length in U). Under these condition we can lower bound the length of γ thanks to [3, Corollary 1.2(c)]. We obtain

$$\frac{\ell(\gamma)}{2} \geq \frac{\pi}{\sqrt{K + H^2}}. \quad (218)$$

We conclude easily. □

B Compactness of the resolvent

Proposition B.1 (Hardy inequality). *Let \mathcal{M} be a non-complete Riemannian manifold with regular metric boundary. Assume, moreover, that the boundaries $\partial\mathcal{M}_\varepsilon^\infty$ are mean convex for sufficiently small ε . Then, for sufficiently small ε , we have*

$$\int_{\mathcal{M}_\varepsilon^\infty} |\nabla u|^2 d\mu_g \geq \frac{1}{8} \int_{\mathcal{M}_\varepsilon^\infty} \frac{|u|^2}{d_\partial^2} d\mu_g, \quad \forall u \in H^1(\mathcal{M}_\varepsilon^\infty). \quad (219)$$

Proof. Fix $\varepsilon > 0$ sufficiently small so that d_∂ is smooth on $\mathcal{M}_0^\varepsilon$ and $\Delta d_\partial = \text{Tr Hess } d_\partial \leq 0$. We start by considering $u \in C_c^\infty(\mathcal{M}_0^\varepsilon)$. Then, an integration by parts yield

$$0 \leq - \int_{\mathcal{M}_0^\varepsilon} |u|^2 d_\partial^{-1} \nabla d_\partial d\mu_g = - \int_{\mathcal{M}_0^\varepsilon} \frac{|u|^2}{d_\partial^2} d\mu_g + 2 \int_{\mathcal{M}_0^\varepsilon} \frac{u}{d_\partial} g(\nabla u, \nabla d_\partial) d\mu_g. \quad (220)$$

Here, we used the fact that $|\nabla d_\partial| \equiv 1$. Finally, the Cauchy-Schwarz inequality yields

$$\int_{\mathcal{M}_0^\varepsilon} \frac{|u|^2}{d_\partial^2} d\mu_g \leq 2 \left(\int_{\mathcal{M}_0^\varepsilon} \frac{|u|^2}{d_\partial^2} d\mu_g \right)^{1/2} \left(\int_{\mathcal{M}_0^\varepsilon} |\nabla u|^2 d\mu_g \right)^{1/2}, \quad (221)$$

thus proving (219) with the bigger constant 1/4 for $u \in C_c^\infty(\mathcal{M}_0^\varepsilon)$. A straightforward density argument then yields

$$\int_{\mathcal{M}_0^\varepsilon} |\nabla u|^2 d\mu_g \geq \frac{1}{4} \int_{\mathcal{M}_0^\varepsilon} \frac{|u|^2}{d_\partial^2} d\mu_g, \quad \forall u \in H_0^1(\mathcal{M}_0^\varepsilon). \quad (222)$$

Let now $u \in C_c^\infty(\mathcal{M}) \cap C^\infty(\mathcal{M}_0^\varepsilon)$. Recall that, up to reducing ε , thanks to the regularity of the metric boundary there exists coordinated $(x, z) \in (0, 2\varepsilon] \times \mathcal{Z}_\varepsilon \simeq \mathcal{M}_0^{2\varepsilon}$ where the metric is as in (76). Then, we let

$$\tilde{u}(x, z) := u(\min\{x, 2\varepsilon - x\}, z). \quad (223)$$

By construction, \tilde{u} is Lipschitz with compact support, smooth on $\mathcal{M}_0^\varepsilon$ and $\mathcal{M}_\varepsilon^{2\varepsilon}$, and coincides with u on $\mathcal{M}_0^\varepsilon$. In particular, $\tilde{u} \in H_0^1(\mathcal{M}_0^{2\varepsilon})$ and thus, by the first part of the proof we have,

$$\int_{\mathcal{M}_0^{2\varepsilon}} |\nabla \tilde{u}|^2 d\mu_g \geq \frac{1}{4} \int_{\mathcal{M}_0^{2\varepsilon}} \frac{|\tilde{u}|^2}{d_\partial^2} d\mu_g \quad (224)$$

In the (x, z) -coordinates, we have $d\mu_g = e^{2\theta(x, z)} dx dz$ for some smooth reference measure dz on \mathcal{Z}_ε and smooth function $\theta : (0, 2\varepsilon] \times \mathcal{Z}_\varepsilon \rightarrow \mathbb{R}$. Furthermore, thanks to the mean convexity assumption, $\partial_x \theta = \frac{1}{2} \text{Tr Hess } d_\partial \leq 0$ and, in particular, $\theta(x, z) \leq \theta(2\varepsilon - x, z)$ for all $x \in [\varepsilon, 2\varepsilon]$. As a consequence, we have

$$\int_{\mathcal{M}_\varepsilon^{2\varepsilon}} |\nabla \tilde{u}|^2 d\mu_g \leq \int_\varepsilon^{2\varepsilon} \int_{\mathcal{Z}_\varepsilon} |\nabla u(2\varepsilon - x, z)|^2 e^{2\theta(2\varepsilon - x, z)} dx dz = \int_{\mathcal{M}_0^\varepsilon} |\nabla u|^2 d\mu_g. \quad (225)$$

The above and (224) yield

$$\int_{\mathcal{M}_0^\varepsilon} |\nabla u|^2 d\mu_g \geq \frac{1}{2} \int_{\mathcal{M}_0^{2\varepsilon}} |\nabla \tilde{u}|^2 d\mu_g \geq \frac{1}{8} \int_{\mathcal{M}_0^{2\varepsilon}} \frac{|\tilde{u}|^2}{d_\partial^2} d\mu_g \geq \frac{1}{8} \int_{\mathcal{M}_0^\varepsilon} \frac{|u|^2}{d_\partial^2} d\mu_g. \quad (226)$$

This completes the proof of the statement for $u \in C_c^\infty(\mathcal{M}) \cap C^\infty(\mathcal{M}_0^\varepsilon)$ and, by density, for $u \in H^1(\mathcal{M}_0^\varepsilon)$. \square

The proof of the following result follows the arguments of [38, Prop. 3.7]. The argument here is simplified thanks to the absence of an external L_{loc}^2 potential.

Theorem B.2 (Compact embedding). *Let \mathcal{M} be a non-complete Riemannian manifold with compact metric completion and regular metric boundary. Assume, moreover, that the boundaries $\partial\mathcal{M}_\varepsilon^\infty$ are mean convex for sufficiently small ε .*

Then, for any domain $\Omega \subset \mathcal{M}$, we have that $H_0^1(\Omega)$ compactly embeds in $L^2(\Omega)$. If, moreover, $\partial\Omega \cap \mathcal{M}$ is Lipschitz, then the same is true for $H^1(\Omega)$.

Proof. Let $(u_n) \subset H_0^1(\Omega)$ be such that $\|u_n\|_{H^1(\Omega)} \leq C$ for some $C > 0$. In order to find a subsequence of $(u_n)_n$ converging in $L^2(\Omega)$ we consider separately the behavior close and far away from the metric boundary. For a fixed $\varepsilon > 0$ sufficiently small, consider two Lipschitz functions $\phi_1, \phi_2 : \mathcal{M} \rightarrow [0, 1]$ such that $\phi_1 + \phi_2 \equiv 1$, $\phi_1 \equiv 1$ on $\mathcal{M}_0^{\varepsilon/2}$, $\text{supp } \phi_1 \subset \mathcal{M}_0^\varepsilon$, and $|\nabla \phi_i| \leq M$ for some $M > 0$. Define $u_{n,i} = \phi_i u_n$, so that, with a slight abuse of notation, $u_{n,1} \in H_0^1(\mathcal{M}_0^\varepsilon)$ and $u_{n,2} \in H_0^1(\mathcal{M}_{\varepsilon/2}^\infty \cap \Omega)$.

By a density argument, a straightforward application of Leibniz rule, and Young inequality, for $i = 1, 2$ we have

$$\int_{\Omega} |\nabla u_{n,i}|^2 d\mu_g \leq \int_{\Omega} |\nabla \phi_i|^2 |u|^2 d\mu_g + \int_{\Omega} (\phi_i^2 + 2|\nabla \phi_i|^2) |\nabla u|^2 d\mu_g. \quad (227)$$

By the fact that $\|u_n\|_{H^1(\Omega)} \leq C$ and that ϕ_i is uniformly Lipschitz, the above implies that, up to enlarging $C > 0$, it holds $\|u_{n,1}\|_{H^1(\mathcal{M}_0^\varepsilon \cap \Omega)} \leq C$ and $\|u_{n,2}\|_{H^1(\mathcal{M}_{\varepsilon/2}^\infty \cap \Omega)} \leq C$. Since $\mathcal{M}_{\varepsilon/4}^\infty$ is a compact Riemannian manifold with smooth boundary, by [23, Corollary 10.21] we have that $H_0^1(\mathcal{M}_{\varepsilon/2}^\infty \cap \Omega)$ compactly embeds in $L^2(\mathcal{M}_{\varepsilon/2}^\infty \cap \Omega) \subset L^2(\Omega)$. Thus, $(u_{n,2})_n$, being bounded in $H_0^1(\mathcal{M}_{\varepsilon/2}^\infty \cap \Omega)$, admits a convergent subsequence in $L^2(\mathcal{M}_{\varepsilon/2}^\infty) \subset L^2(\mathcal{M})$.

On the other hand, by the Hardy inequality of Proposition B.1, we have

$$\|u_{n,1}\|_{L^2(\mathcal{M}_0^\varepsilon \cap \Omega)}^2 = \int_{\mathcal{M}_0^\varepsilon} |u_{n,1}|^2 d\mu_g \leq 8\varepsilon^2 \int_{\mathcal{M}_0^\varepsilon} |\nabla u_{n,1}|^2 \leq 8C\varepsilon^2, \quad (228)$$

where we used the boundedness of $(u_{n,1})_n$ in $H^1(\mathcal{M}_0^\varepsilon) \cap \Omega$. Then, by choosing $\varepsilon = \varepsilon_k = (\sqrt{8Ck})^{-1}$, we obtain that for any $k \in \mathbb{N}$ there exists a subsequence $n \mapsto \gamma_k(n)$ such that $u_{\gamma_k(n)} = u_{\gamma_k(n),1} + u_{\gamma_k(n),2}$ with $\|u_{\gamma_k(n),1}\| \leq 1/k$ and $(u_{\gamma_k(n),2})_n$ convergent in $L^2(\mathcal{M})$. A diagonal argument (see the proof of [38, Prop. 3.7]) yields the existence of a subsequence of $(u_n)_n$ convergent in $L^2(\mathcal{M})$, completing the proof of the first part of the statement.

The same argument applies to prove the second part of the statement. The main difference is that, in this case, $u_{n,2} \in H^1(\mathcal{M}_{\varepsilon/2}^\infty \cap \Omega)$. However, under the additional assumption of regularity of $\partial\Omega \cap \mathcal{M}$, we have that $H^1(\mathcal{M}_{\varepsilon/2}^\infty \cap \Omega)$ compactly embeds in $L^2(\mathcal{M}_{\varepsilon/2}^\infty \cap \Omega)$ since, up to taking a slightly smaller ε , the boundary of $\mathcal{M}_{\varepsilon/2}^\infty \cap \Omega$ is Lipschitz⁵. \square

Corollary B.3. *Let \mathcal{M} be a non-complete Riemannian manifold with compact metric completion and regular metric boundary. Assume, moreover, that the boundaries $\partial\mathcal{M}_\varepsilon^\infty$ are mean convex for sufficiently small ε . Then, for any domain $\Omega \subset \mathcal{M}$ such that $\partial\Omega \cap \mathcal{M}$ is Lipschitz, the resolvents $(\Delta_\Omega^\pm - z)^{-1}$ of the Dirichlet and Neumann Laplace-Beltrami operators are compact for any $z > 0$. In particular, the spectrum of Δ_Ω^\pm is discrete.*

Proof. By Theorem B.2, it holds that $H^1(\Omega)$ compactly embed in $L^2(\Omega)$. Since $D(\Delta_\Omega^\pm) \subset H^1(\Omega)$ this implies the compactness of the resolvent. To this effect, and for completeness sake, we replicate the argument of [23, Theorem 10.20].

⁵We were not able to find the required statement in the literature, but the result follows by the arguments of [23, Corollary 10.21, Second proof] and the Euclidean Rellich-Kondrakov Theorem [1, Theorem 6.3].

Since Δ_{Ω}^{\pm} is a non-positive operator, its resolvent set contains $(0, +\infty)$. Thus, for $z > 0$, $R_z := (\Delta_{\Omega}^{\pm} - z)^{-1}$ is a bounded self-adjoint operator in $L^2(\Omega)$. Moreover, for any $\psi \in L^2(\Omega)$ we have $u := R_z \psi \in D(\Delta_{\Omega}^{\pm}) \subset H^1(\Omega)$, whence

$$\int_{\Omega} |\nabla u|^2 d\mu_g + z \int_{\Omega} |u|^2 d\mu_g = - \int_{\Omega} (\Delta_{\Omega}^{\pm} u - zu) \bar{u} d\mu_g = - \int_{\Omega} \psi \bar{u} d\mu_g. \quad (229)$$

By Cauchy-Schwarz inequality this implies

$$\min\{1, z\} \|u\|_{H^1}^2 \leq \left| \int_{\Omega} \psi \bar{u} d\mu_g \right| \leq \|u\|_{L^2} \|\psi\|_{L^2} \leq \|u\|_{H^1} \|\psi\|_{L^2}. \quad (230)$$

We then get $\|R_z \psi\|_{H^1} \leq \max\{1, z^{-1}\} \|\psi\|_{L^2}$ for any $\psi \in L^2(\Omega)$. That is, $\tilde{R}_z : L^2(\Omega) \rightarrow H^1(\Omega)$, defined by $\tilde{R}_z \psi := R_z \psi$, is a bounded operator. Letting $\iota : H^1(\Omega) \rightarrow L^2(\Omega)$ be the compact embedding operator, we have that $R_z = \iota \circ \tilde{R}_z$. We have thus shown that R_z is the composition of a bounded operator with a compact one, and thus is compact itself. \square

References

- [1] Robert A. Adams and John J. F. Fournier. *Sobolev spaces*, volume 140 of *Pure and Applied Mathematics (Amsterdam)*. Elsevier/Academic Press, Amsterdam, second edition, 2003.
- [2] Andrei Agrachev, Ugo Boscain, and Mario Sigalotti. A Gauss-Bonnet-like formula on two-dimensional almost-Riemannian manifolds. *Discrete Contin. Dyn. Syst.*, 20(4):801–822, 2008.
- [3] Stephanie B. Alexander and Richard L. Bishop. Comparison theorems for curves of bounded geodesic curvature in metric spaces of curvature bounded above. *Differential Geom. Appl.*, 6(1):67–86, 1996.
- [4] Luigi Ambrosio, Shouhei Honda, and David Tewodrose. Short-time behavior of the heat kernel and Weyl’s law on $\text{RCD}^*(K, N)$ spaces. *Ann. Global Anal. Geom.*, 53(1):97–119, 2018.
- [5] Arthur L. Besse. *Einstein manifolds*. Classics in Mathematics. Springer-Verlag, Berlin, 2008. Reprint of the 1987 edition.
- [6] N. H. Bingham, C. M. Goldie, and J. L. Teugels. *Regular variation*, volume 27 of *Encyclopedia of Mathematics and its Applications*. Cambridge University Press, Cambridge, 1989.
- [7] U. Boscain, D. Prandi, and M. Seri. Spectral analysis and the Aharonov-Bohm effect on certain almost-Riemannian manifolds. *Comm. Partial Differential Equations*, 41(1):32–50, 2016.
- [8] Ugo Boscain and Camille Laurent. The Laplace-Beltrami operator in almost-Riemannian geometry. *Ann. Inst. Fourier (Grenoble)*, 63(5):1739–1770, 2013.
- [9] Peter Buser. A note on the isoperimetric constant. *Ann. Sci. École Norm. Sup. (4)*, 15(2):213–230, 1982.

- [10] Isaac Chavel. *Eigenvalues in Riemannian geometry*, volume 115 of *Pure and Applied Mathematics*. Academic Press, Inc., Orlando, FL, 1984. Including a chapter by Burton Randol, With an appendix by Jozef Dodziuk.
- [11] Jeff Cheeger. Spectral geometry of singular Riemannian spaces. *J. Differential Geom.*, 18(4):575–657 (1984), 1983.
- [12] Jeff Cheeger and David G. Ebin. *Comparison theorems in Riemannian geometry*. AMS Chelsea Publishing, Providence, RI, 2008. Revised reprint of the 1975 original.
- [13] Y. Colin de Verdière. Ergodicité et fonctions propres du laplacien. *Comm. Math. Phys.*, 102(3):497–502, 1985.
- [14] Yves Colin de Verdière. L’asymptotique de Weyl pour les bouteilles magnétiques. *Comm. Math. Phys.*, 105(2):327–335, 1986.
- [15] Yves Colin de Verdière. Construction de laplaciens dont une partie finie du spectre est donnée. *Ann. Sci. École Norm. Sup. (4)*, 20(4):599–615, 1987.
- [16] Yves Colin de Verdière, Luc Hillairet, and Emmanuel Trélat. Spectral asymptotics for sub-Riemannian Laplacians. II: microlocal Weyl measures. *Work in progress*.
- [17] Yves Colin de Verdière, Luc Hillairet, and Emmanuel Trélat. Quantum ergodicity and quantum limits for sub-Riemannian Laplacians. In *Séminaire Laurent Schwartz—Équations aux dérivées partielles et applications. Année 2014–2015*, pages Exp. No. XX, 17. Ed. Éc. Polytech., Palaiseau, 2016.
- [18] Yves Colin de Verdière, Luc Hillairet, and Emmanuel Trélat. Spectral asymptotics for sub-Riemannian Laplacians, I: Quantum ergodicity and quantum limits in the 3-dimensional contact case. *Duke Math. J.*, 167(1):109–174, 2018.
- [19] R. Courant and D. Hilbert. *Methods of mathematical physics. Vol. I*. Interscience Publishers, Inc., New York, N.Y., 1953.
- [20] Arnold L. M. Dekkers and Laurens de Haan. Optimal choice of sample fraction in extreme-value estimation. *J. Multivariate Anal.*, 47(2):173–195, 1993.
- [21] Yu Ding. Heat kernels and Green’s functions on limit spaces. *Comm. Anal. Geom.*, 10(3):475–514, 2002.
- [22] Kenji Fukaya. Collapsing of Riemannian manifolds and eigenvalues of Laplace operator. *Invent. Math.*, 87(3):517–547, 1987.
- [23] Alexander Grigor’yan. *Heat kernel and analysis on manifolds*, volume 47 of *AMS/IP Studies in Advanced Mathematics*. American Mathematical Society, Providence, RI; International Press, Boston, MA, 2009.
- [24] Alexander Grigoryan and L Saloff-Coste. Heat kernel on manifolds with ends. *Annales de l’institut Fourier*, 59(5):1917–1997, 2009.
- [25] Asma Hassannezhad, Gerasim Kokarev, and Iosif Polterovich. Eigenvalue inequalities on Riemannian manifolds with a lower Ricci curvature bound. *J. Spectr. Theory*, 6(4):807–835, 2016.
- [26] A. E. Ingham. On Tauberian theorems. *Proc. London Math. Soc. (3)*, 14a:157–173, 1965.

- [27] J. Karamata. Neuer Beweis und Verallgemeinerung einiger Tauberian-Sätze. *Math. Z.*, 33(1):294–299, 1931.
- [28] John Lamperti. An occupation time theorem for a class of stochastic processes. *Transactions of the American Mathematical Society*, 88(2):380–380, 1958.
- [29] Peter Li and Shing-Tung Yau. On the parabolic kernel of the Schrödinger operator. *Acta Math.*, 156(3-4):153–201, 1986.
- [30] Maria Lianantonakis. On the eigenvalue counting function for weighted Laplace-Beltrami operators. *J. Geom. Anal.*, 10(2):299–322, 2000.
- [31] H. P. McKean, Jr. and I. M. Singer. Curvature and the eigenvalues of the Laplacian. *J. Differential Geometry*, 1(1):43–69, 1967.
- [32] Abderemane Morame and Françoise Truc. Magnetic bottles on the Poincaré half-plane: spectral asymptotics. *J. Math. Kyoto Univ.*, 48(3):597–616, 2008.
- [33] Abderemane Morame and Françoise Truc. Magnetic bottles on geometrically finite hyperbolic surfaces. *J. Geom. Phys.*, 59(7):1079–1085, 2009.
- [34] Gheorghe Nenciu and Irina Nenciu. On confining potentials and essential self-adjointness for Schrödinger operators on bounded domains in \mathbb{R}^n . *Ann. Henri Poincaré*, 10(2):377–394, 2009.
- [35] G. Perelman. Construction of manifolds of positive Ricci curvature with big volume and large Betti numbers. In *Comparison geometry (Berkeley, CA, 1993–94)*, volume 30 of *Math. Sci. Res. Inst. Publ.*, pages 157–163. Cambridge Univ. Press, Cambridge, 1997.
- [36] Karl Petersen. *Ergodic theory*, volume 2 of *Cambridge Studies in Advanced Mathematics*. Cambridge University Press, Cambridge, 1983.
- [37] Peter Petersen. *Riemannian geometry*, volume 171 of *Graduate Texts in Mathematics*. Springer, Cham, third edition, 2016.
- [38] Dario Prandi, Luca Rizzi, and Marcello Seri. Quantum confinement on non-complete Riemannian manifolds. *J. Spectr. Theory*, 8(4):1221–1280, 2018.
- [39] Steven Rosenberg. *The Laplacian on a Riemannian manifold*, volume 31 of *London Mathematical Society Student Texts*. Cambridge University Press, Cambridge, 1997. An introduction to analysis on manifolds.
- [40] Barry Simon. Nonclassical eigenvalue asymptotics. *J. Funct. Anal.*, 53(1):84–98, 1983.
- [41] A. Suleymanova. Heat trace expansion on manifolds with conic singularities. *ArXiv e-prints*, January 2017.
- [42] A. Suleymanova. On the spectral geometry of manifolds with conic singularities. *ArXiv e-prints*, October 2017.
- [43] M. van den Berg. Dirichlet-Neumann bracketing for horn-shaped regions. *J. Funct. Anal.*, 104(1):110–120, 1992.

- [44] Hermann Weyl. Das asymptotische Verteilungsgesetz der Eigenwerte linearer partieller Differentialgleichungen (mit einer Anwendung auf die Theorie der Hohlraumstrahlung). *Math. Ann.*, 71(4):441–479, 1912.
- [45] Jeremy Wong. An extension procedure for manifolds with boundary. *Pacific J. Math.*, 235(1):173–199, 2008.
- [46] H.-C. Zhang and X.-P. Zhu. Weyl’s law on $RCD^*(K, N)$ metric measure spaces. *Comm. Anal. Geom. (in press)*, January 2017.