



HAL
open science

Dynamics under location uncertainty: model derivation, modified transport and uncertainty quantification

Valentin Resseguier, Baylor Fox-Kemper, Etienne Mémin, Bertrand Chapron

► **To cite this version:**

Valentin Resseguier, Baylor Fox-Kemper, Etienne Mémin, Bertrand Chapron. Dynamics under location uncertainty: model derivation, modified transport and uncertainty quantification. AGU 2017 - American Geophysical Union, Dec 2017, New Orleans, United States. pp.1-47. hal-01891163

HAL Id: hal-01891163

<https://hal.science/hal-01891163>

Submitted on 9 Oct 2018

HAL is a multi-disciplinary open access archive for the deposit and dissemination of scientific research documents, whether they are published or not. The documents may come from teaching and research institutions in France or abroad, or from public or private research centers.



L'archive ouverte pluridisciplinaire **HAL**, est destinée au dépôt et à la diffusion de documents scientifiques de niveau recherche, publiés ou non, émanant des établissements d'enseignement et de recherche français ou étrangers, des laboratoires publics ou privés.

Dynamics under location uncertainty: model derivation, modified transport and uncertainty quantification

Valentin Resseguier, Baylor Fox-Kemper
Etienne Memin, Bertrand Chapron

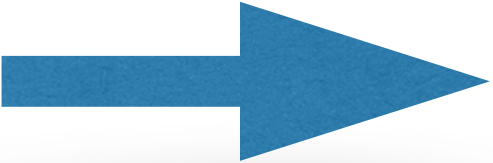

Motivations

- Rigorously identified subgrid dynamics effects
- Injecting likely small-scale dynamics
- Predict extreme events
- Quantification of modeling errors  Ensemble forecasts and data assimilation
- Studying different likely scenarios and attractors  Climate projections

Contents

I. Location uncertainty

II. SQG under moderate uncertainty

Part I

Location uncertainty

Adding random velocity

$$\boldsymbol{v} = \boldsymbol{w} + \sigma \dot{\boldsymbol{B}}$$

Adding random velocity

Resolved
large scales

$$\boldsymbol{v} = \boldsymbol{w} + \sigma \dot{\boldsymbol{B}}$$

Adding random velocity

Resolved
large scales

White-in-time
small scales

$$\boldsymbol{v} = \boldsymbol{w} + \sigma \dot{\boldsymbol{B}}$$

Large scales:
 w
Small scales:
 $\sigma \dot{B}$
Variance
tensor:
 $a = a(x, x) =$
 $\frac{\mathbb{E}\{\sigma dB (\sigma dB)^T\}}{dt}$

Adding random velocity

Resolved
large scales

White-in-time
small scales

$$v = w + \sigma \dot{B}$$

Large scales:

w

Small scales:

$\sigma \dot{B}$

Variance
tensor:

$$a = a(x, x) = \frac{\mathbb{E}\{\sigma dB (\sigma dB)^T\}}{dt}$$

Adding random velocity

Resolved
large scales

White-in-time
small scales

$$v = w + \sigma \dot{B}$$

References :

Mikulevicius and Rozovskii, 2004
Flandoli, 2011

Memin, 2014
Resseguier et al. 2017 a, b, c
Chapron et al. 2017
Cai et al. 2017

Holm, 2015
Holm and Tyranowski, 2016
Arnaudon et al., 2017

Cotter and al 2017
Crisan et al., 2017
Gay-Balmaz and Holm 2017

Large scales:

w

Small scales:

$\sigma \dot{B}$

Variance
tensor:

$$a = a(x, x) = \frac{\mathbb{E}\{\sigma dB (\sigma dB)^T\}}{dt}$$

Advection of tracer Θ

$$\frac{D\Theta}{Dt} = 0$$

Large scales:

w

Small scales:

$\sigma \dot{B}$

Variance
tensor:

$a = a(x, x) =$

$$\frac{\mathbb{E}\{\sigma dB (\sigma dB)^T\}}{dt}$$

Advection of tracer Θ

Large scales:

w

Small scales:

$\sigma \dot{B}$

Variance
tensor:

$$a = a(x, x) = \frac{\mathbb{E}\{\sigma dB (\sigma dB)^T\}}{dt}$$

Advection of tracer Θ

$$\partial_t \Theta + w^* \cdot \nabla \Theta + \sigma \dot{B} \cdot \nabla \Theta = \nabla \cdot \left(\frac{1}{2} a \nabla \Theta \right)$$

Large scales:

w

Small scales:

$\sigma \dot{B}$

Variance
tensor:

$a = a(x, x) =$

$\frac{\mathbb{E}\{\sigma dB (\sigma dB)^T\}}{dt}$

Advection of tracer Θ

$$\partial_t \Theta + \underbrace{w^* \cdot \nabla \Theta + \sigma \dot{B} \cdot \nabla \Theta}_{\text{Advection}} = \nabla \cdot \left(\frac{1}{2} a \nabla \Theta \right)$$

Large scales:

w

Small scales:

$\sigma \dot{B}$

Variance
tensor:

$a = a(x, x) =$

$\frac{\mathbb{E}\{\sigma dB (\sigma dB)^T\}}{dt}$

Advection of tracer Θ

$$\partial_t \Theta + \underbrace{w^* \cdot \nabla \Theta + \sigma \dot{B} \cdot \nabla \Theta}_{\text{Advection}} = \underbrace{\nabla \cdot \left(\frac{1}{2} a \nabla \Theta \right)}_{\text{Diffusion}}$$

Large scales:
 w

Small scales:
 $\sigma \dot{B}$

Variance tensor:
 $a = a(x, x) = \frac{\mathbb{E}\{\sigma dB (\sigma dB)^T\}}{dt}$

Advection of tracer Θ

$$\partial_t \Theta + \underbrace{w^* \cdot \nabla \Theta + \sigma \dot{B} \cdot \nabla \Theta}_{\text{Advection}} = \underbrace{\nabla \cdot \left(\frac{1}{2} a \nabla \Theta \right)}_{\text{Diffusion}}$$

Drift correction

Large scales:
 w
 Small scales:
 $\sigma \dot{B}$
 Variance
 tensor:
 $a = a(x, x) =$
 $\frac{\mathbb{E}\{\sigma dB (\sigma dB)^T\}}{dt}$

Advection of tracer Θ

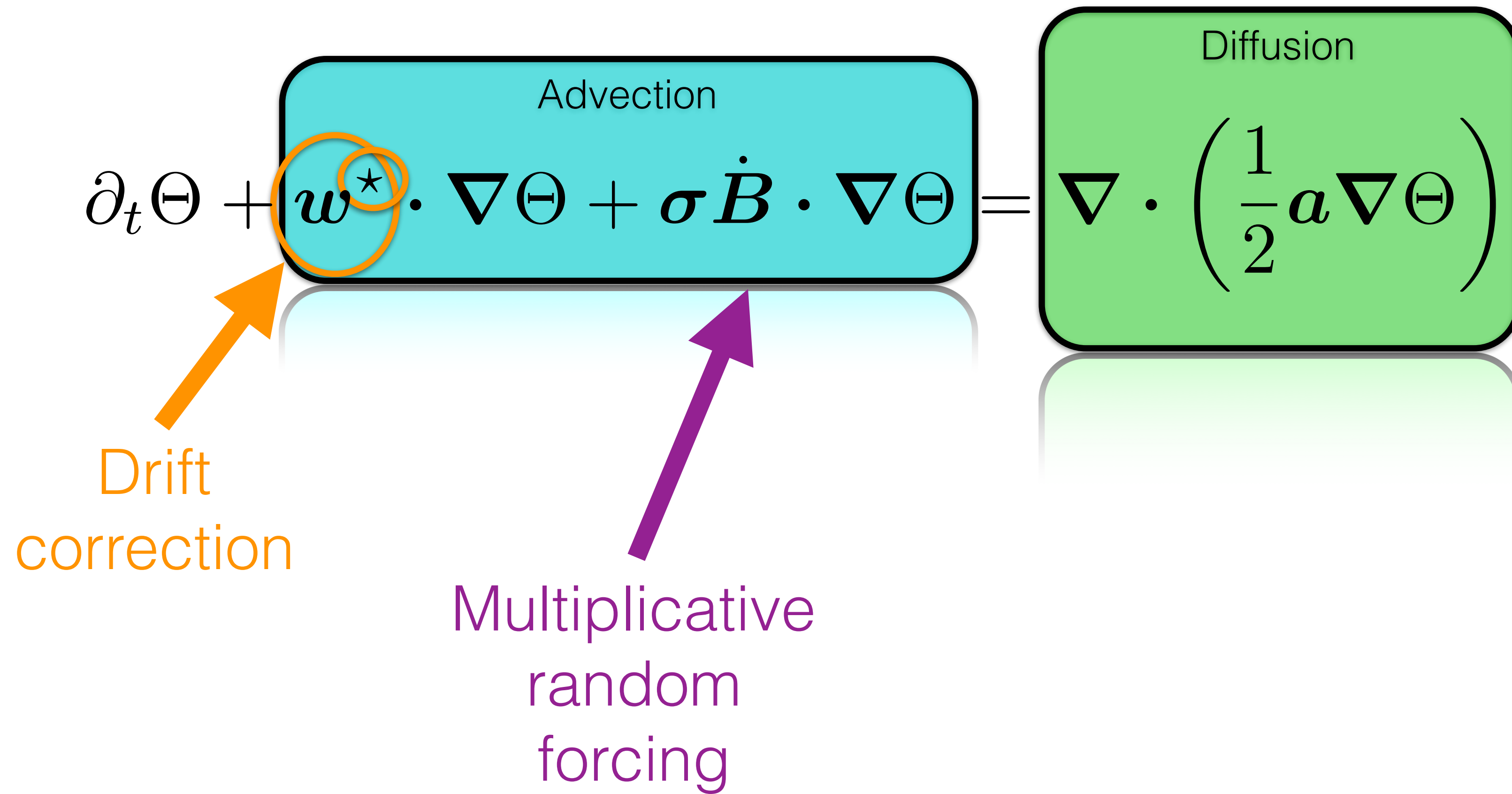

Large scales:
 w

Small scales:
 $\sigma \dot{B}$

Variance tensor:
 $a = a(x, x) = \frac{\mathbb{E}\{\sigma dB (\sigma dB)^T\}}{dt}$

Advection of tracer Θ

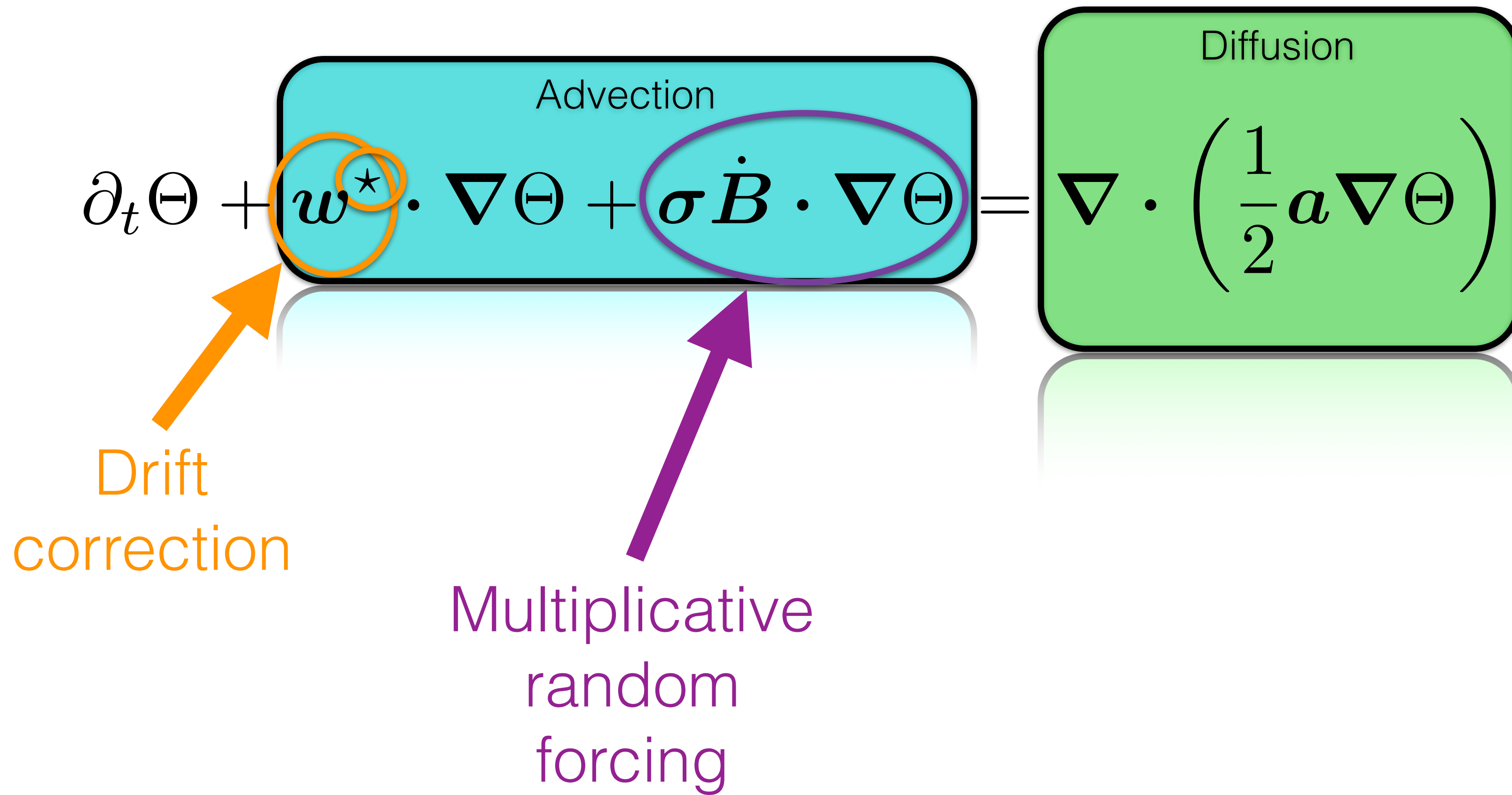

Large scales:
 w

Small scales:
 $\sigma \dot{B}$

Variance tensor:
 $a = a(x, x) = \frac{\mathbb{E}\{\sigma dB (\sigma dB)^T\}}{dt}$

Advection of tracer Θ

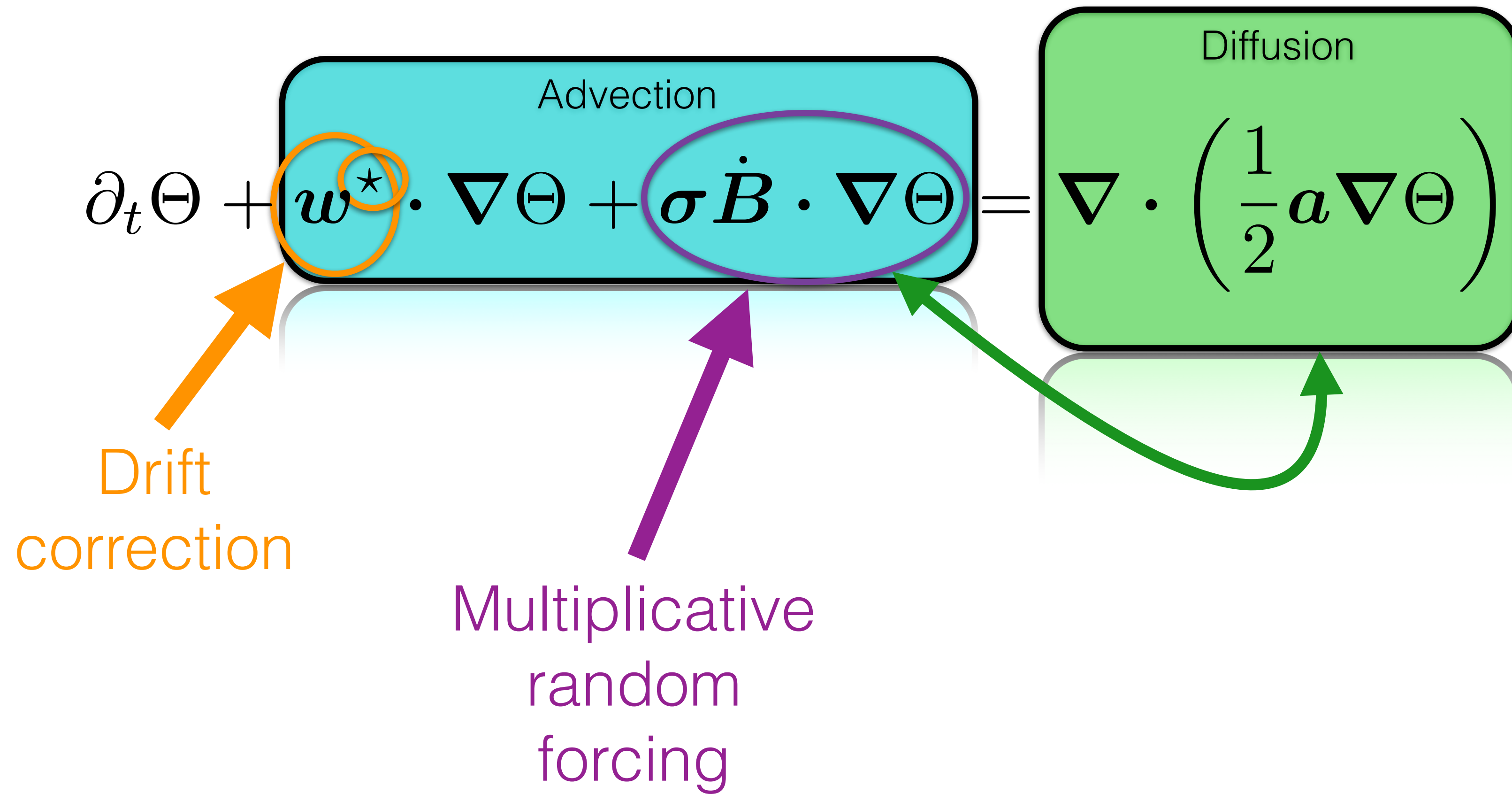

Large scales:
 w
 Small scales:
 $\sigma \dot{B}$
 Variance
 tensor:
 $a = a(x, x) =$
 $\frac{\mathbb{E}\{\sigma dB (\sigma dB)^T\}}{dt}$

Advection of tracer Θ

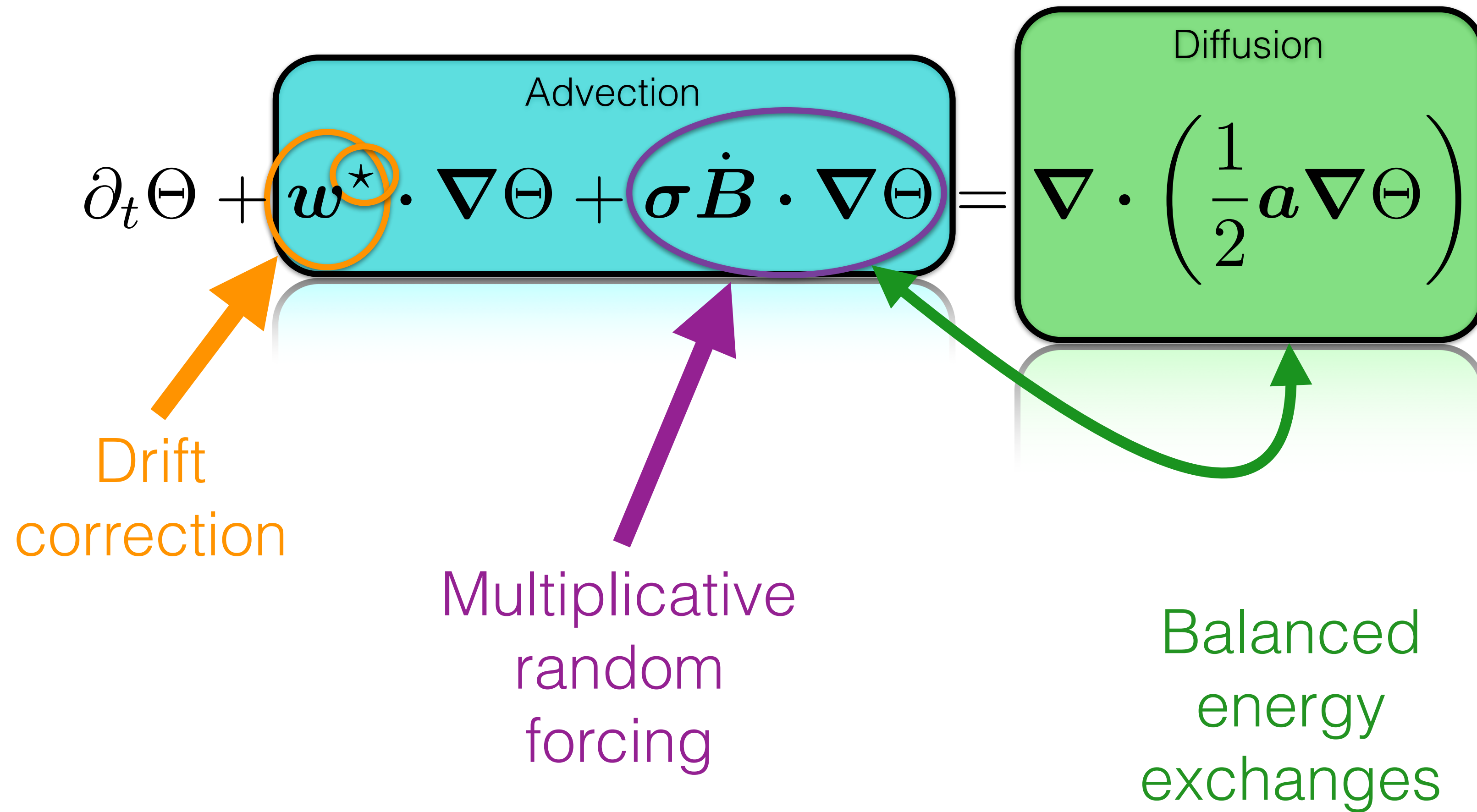

Derived random models

Large scales:

w

Small scales:

$\sigma \dot{B}$

Variance
tensor:

$a = a(x, x) =$

$$\frac{\mathbb{E}\{\sigma dB (\sigma dB)^T\}}{dt}$$

Conservations
(mass, linear
momentum, ...)

$$\frac{D}{Dt}$$

Navier-Stokes

Derived random models

Large scales:

w

Small scales:

$\sigma \dot{B}$

Variance
tensor:

$$a = a(x, x) = \frac{\mathbb{E}\{\sigma dB (\sigma dB)^T\}}{dt}$$

Conservations
(mass, linear
momentum, ...)

$$\frac{D}{Dt}$$

Navier-Stokes

Simplifications

Derived random models

Large scales:
 w

Small scales:
 $\sigma \dot{B}$

Variance tensor:
 $a = a(x, x) = \frac{\mathbb{E}\{\sigma dB (\sigma dB)^T\}}{dt}$

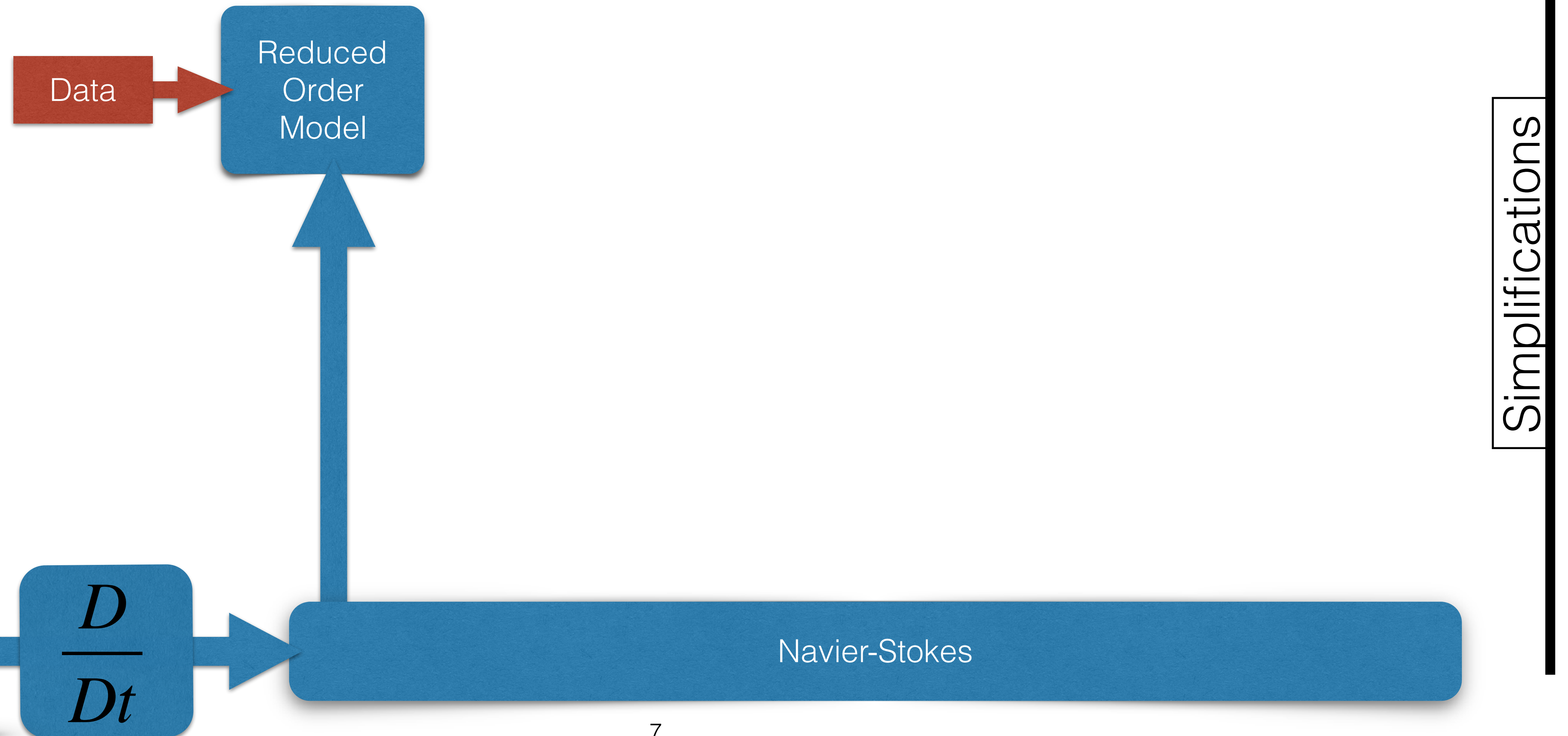

Derived random models

Large scales:
 w

Small scales:
 $\sigma \dot{B}$

Variance tensor:
 $a = a(x, x) = \frac{\mathbb{E}\{\sigma dB (\sigma dB)^T\}}{dt}$

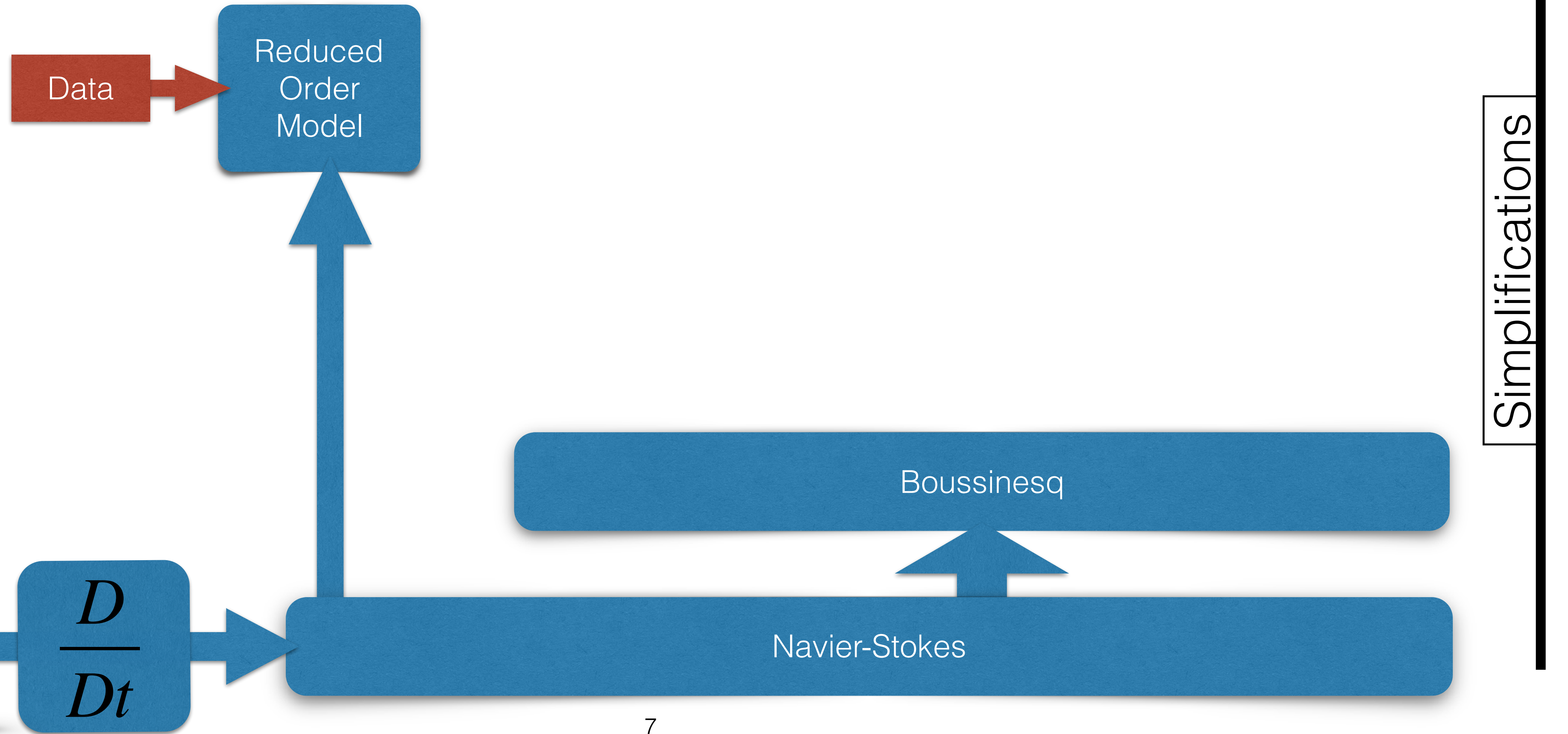

Derived random models

Large scales:
 w

Small scales:
 $\sigma \dot{B}$

Variance tensor:
 $a = a(x, x) = \frac{\mathbb{E}\{\sigma dB (\sigma dB)^T\}}{dt}$

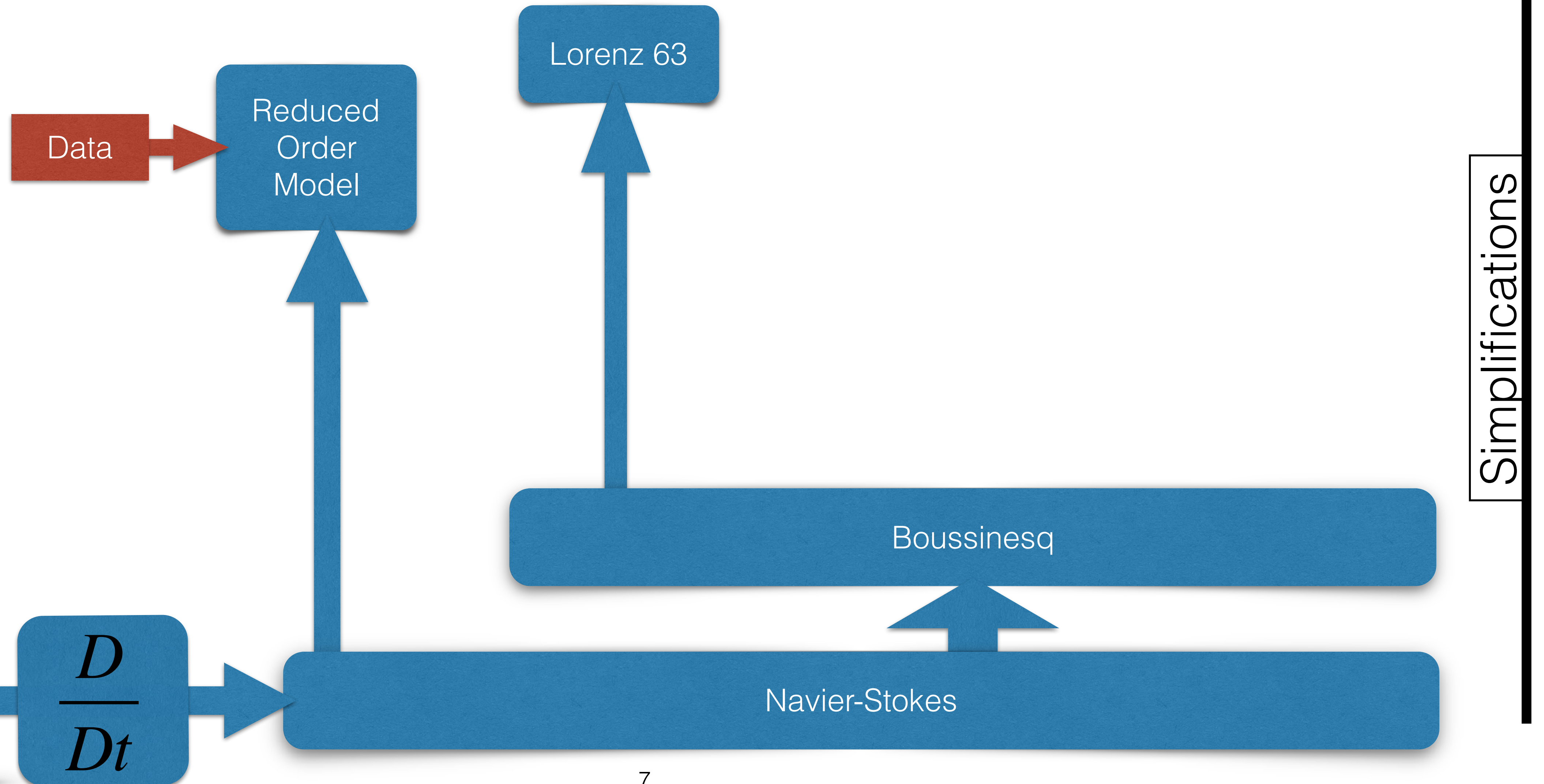

Derived random models

Large scales:
 w

Small scales:
 $\sigma \dot{B}$

Variance tensor:
 $a = a(x, x) = \frac{\mathbb{E}\{\sigma dB (\sigma dB)^T\}}{dt}$

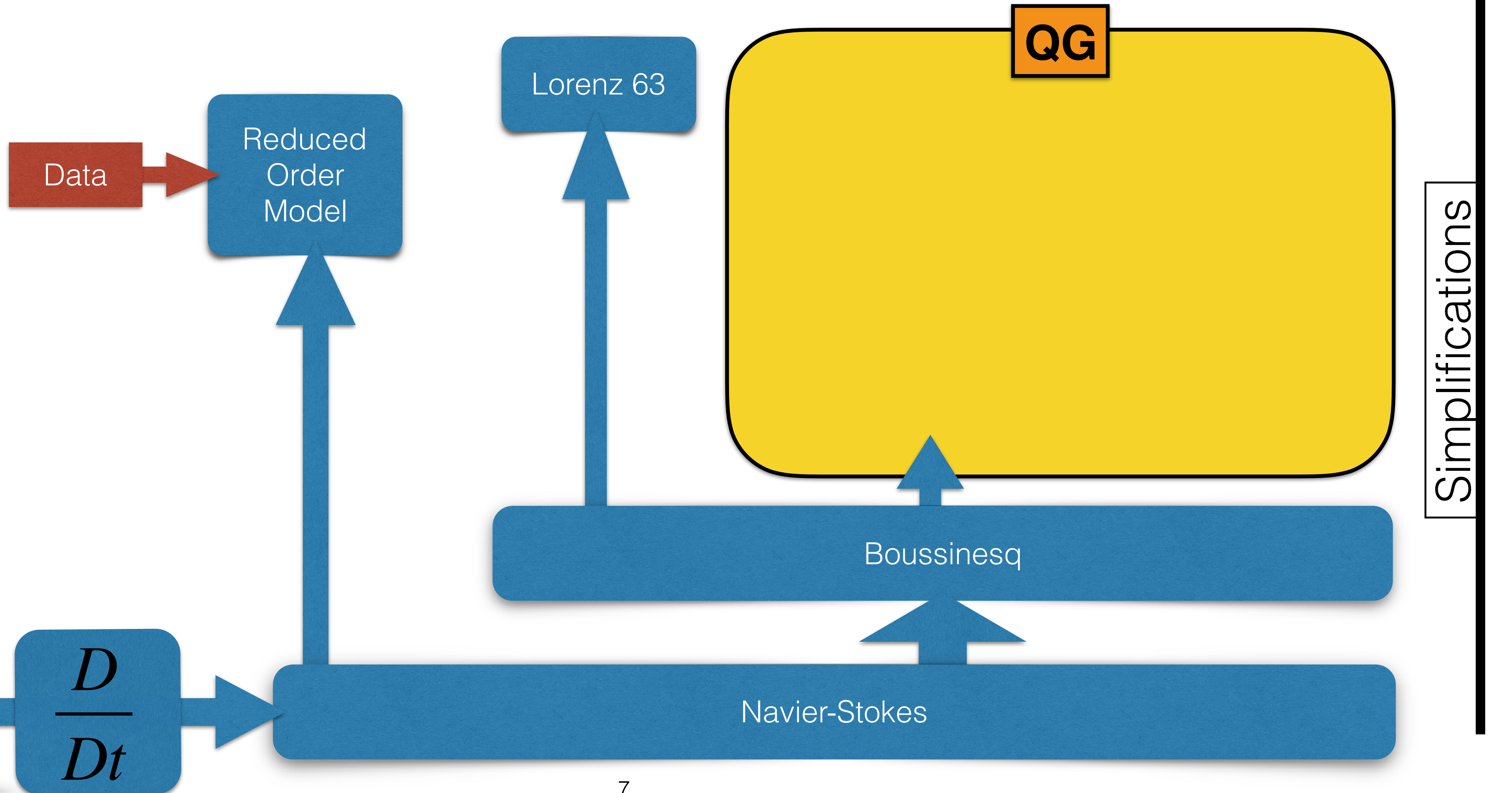

Derived random models

Large scales:
 w
 Small scales:
 $\sigma \dot{B}$
 Variance tensor:
 $a = a(x, x) = \frac{\mathbb{E}\{\sigma dB (\sigma dB)^T\}}{dt}$

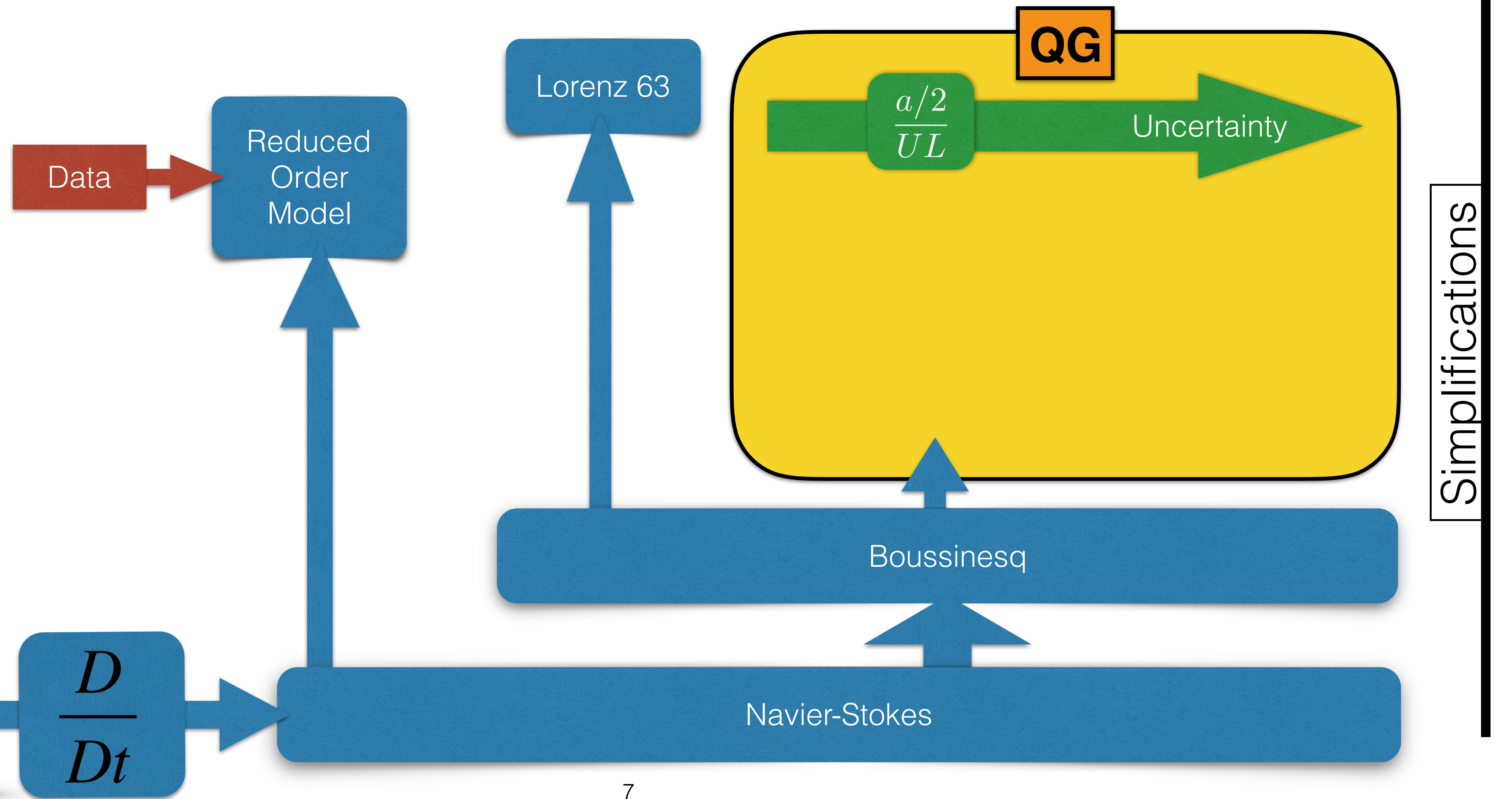

Conservations
 (mass, linear
 momentum, ...)

$$\frac{D}{Dt}$$

Derived random models

Large scales:
 w
 Small scales:
 $\sigma \dot{B}$
 Variance tensor:
 $a = a(x, x) = \frac{\mathbb{E}\{\sigma dB (\sigma dB)^T\}}{dt}$

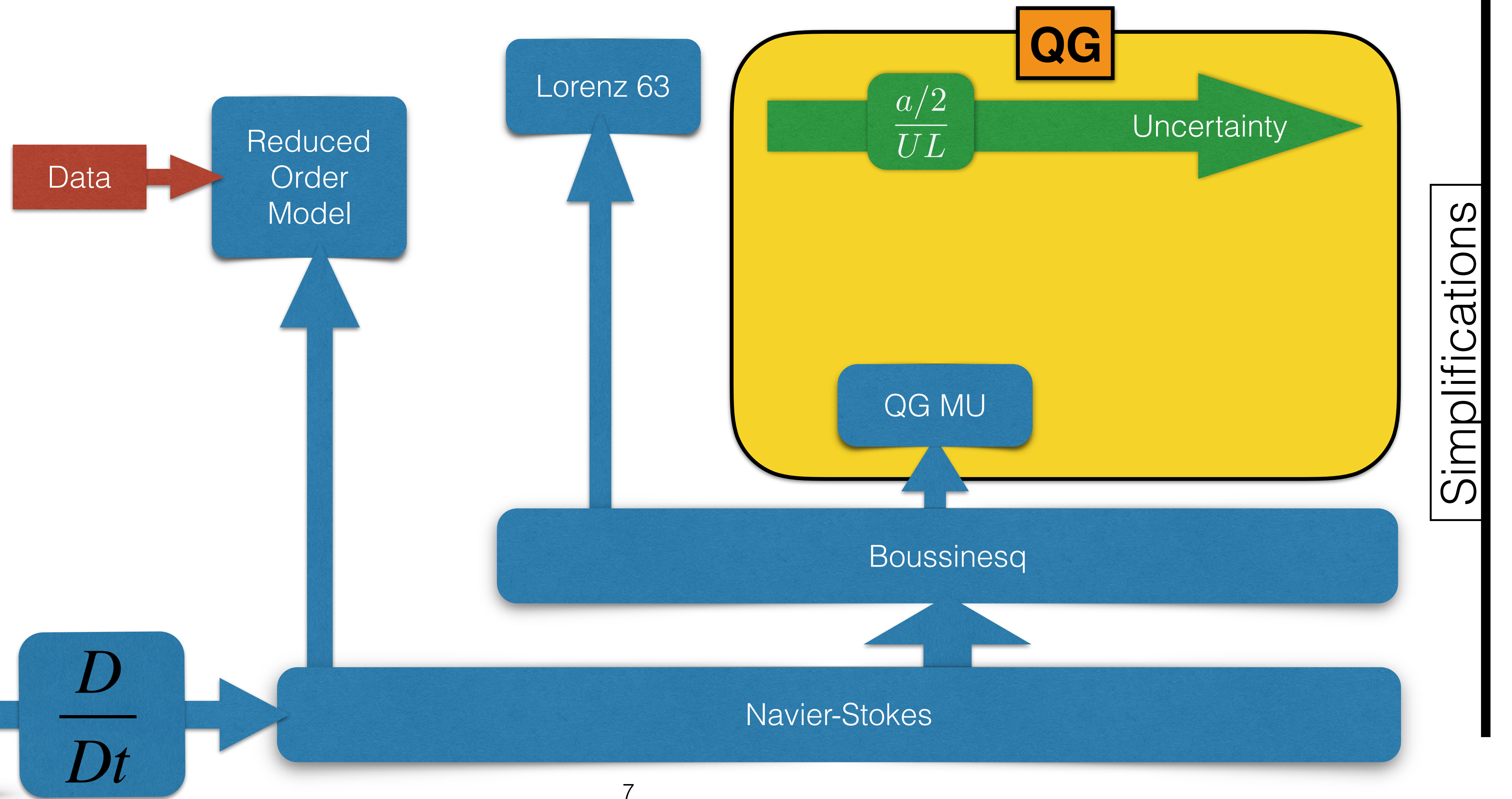

Conservations
 (mass, linear
 momentum, ...)

$$\frac{D}{Dt}$$

Derived random models

Large scales:
 w

Small scales:
 $\sigma \dot{B}$

Variance tensor:
 $a = a(x, x) = \frac{\mathbb{E}\{\sigma dB (\sigma dB)^T\}}{dt}$

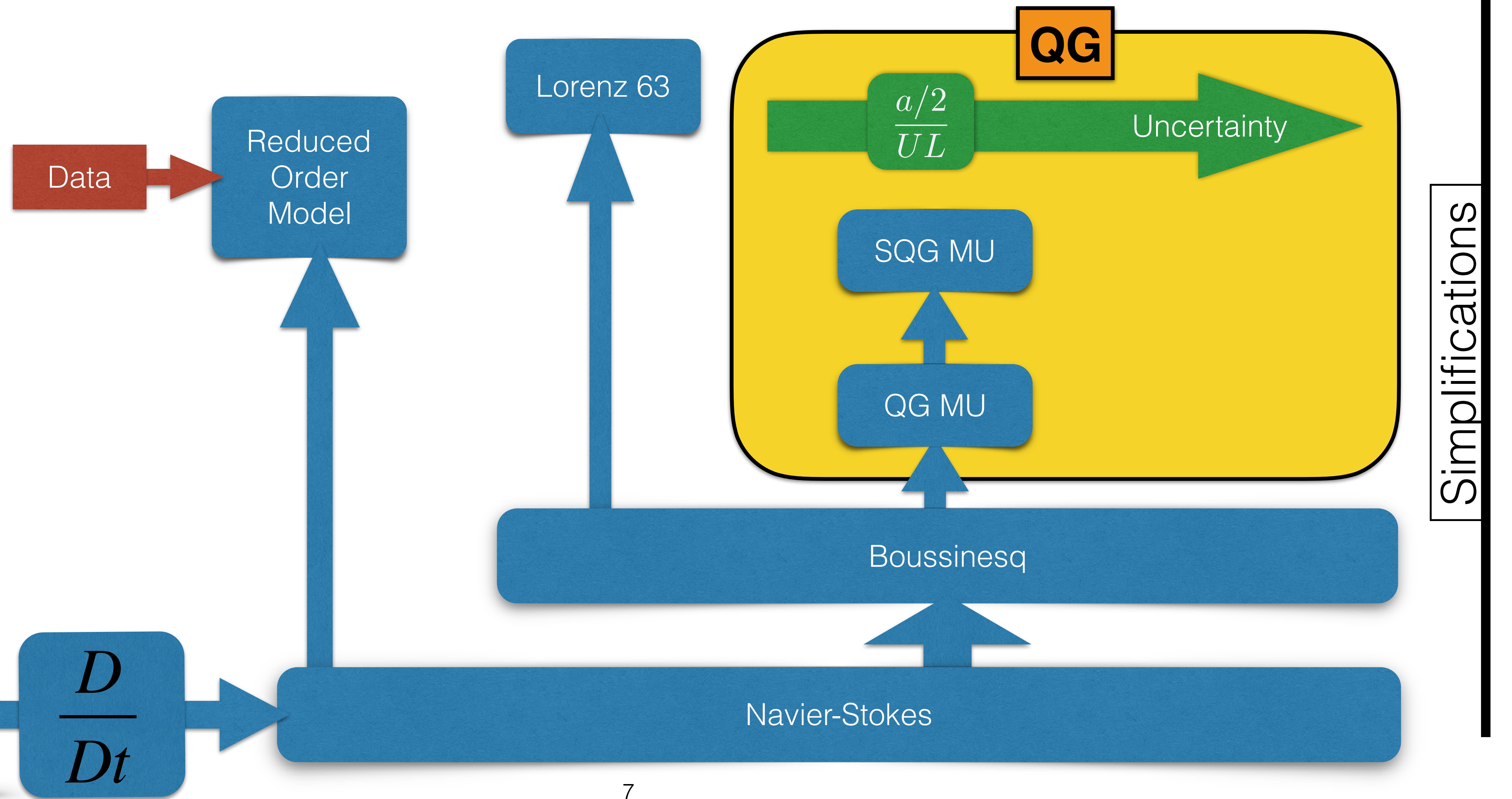

Derived random models

Large scales:
 w
 Small scales:
 $\sigma \dot{B}$
 Variance tensor:
 $a = a(x, x) = \frac{\mathbb{E}\{\sigma dB (\sigma dB)^T\}}{dt}$

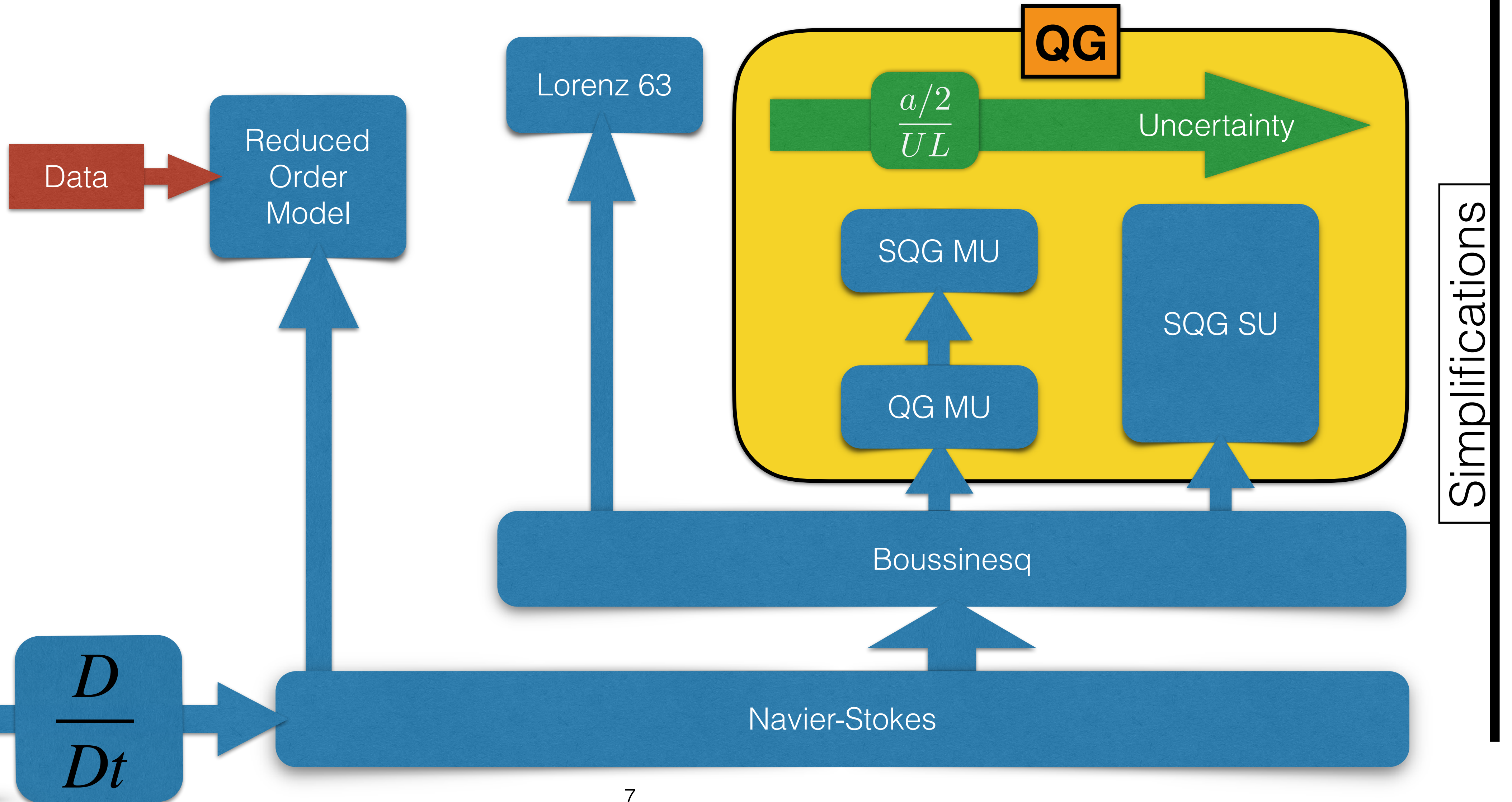

Derived random models

Large scales:
 w
 Small scales:
 $\sigma \dot{B}$
 Variance tensor:
 $a = a(x, x) = \frac{\mathbb{E}\{\sigma dB (\sigma dB)^T\}}{dt}$

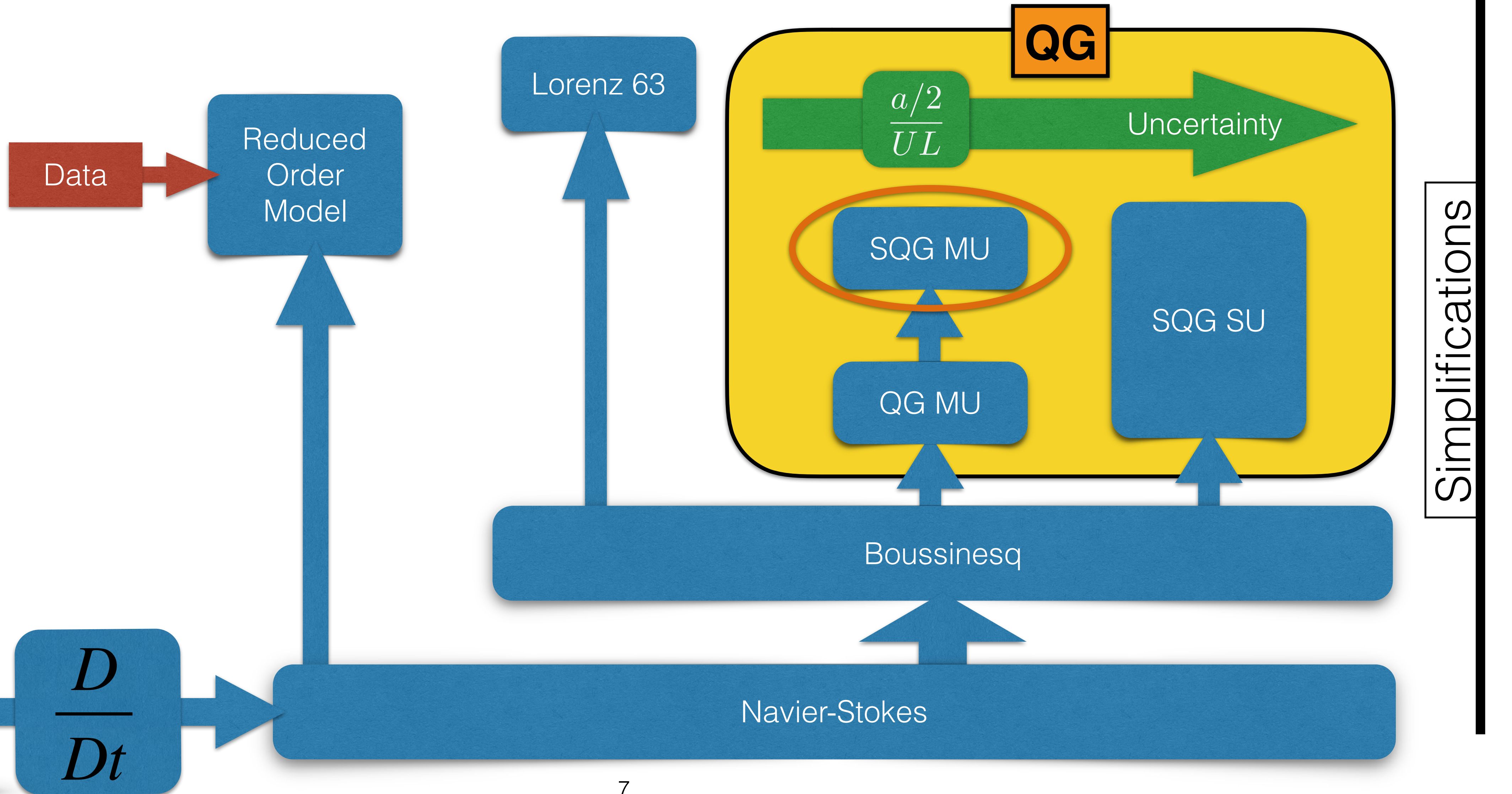

Conservations
 (mass, linear
 momentum, ...)

$$\frac{D}{Dt}$$

Part II

SQG under Moderate Uncertainty

SQG MU

Code available online

$t = 17$ day

SQG

$$\frac{Db}{Dt} = -\alpha_{HV} \Delta^4 b \quad \text{Hyper-viscosity}$$

$$\mathbf{u} = \left(\text{cst.} \nabla^\perp \Delta^{-\frac{1}{2}} \right) b$$

Reference flow:

deterministic

SQG

1024 x 1024

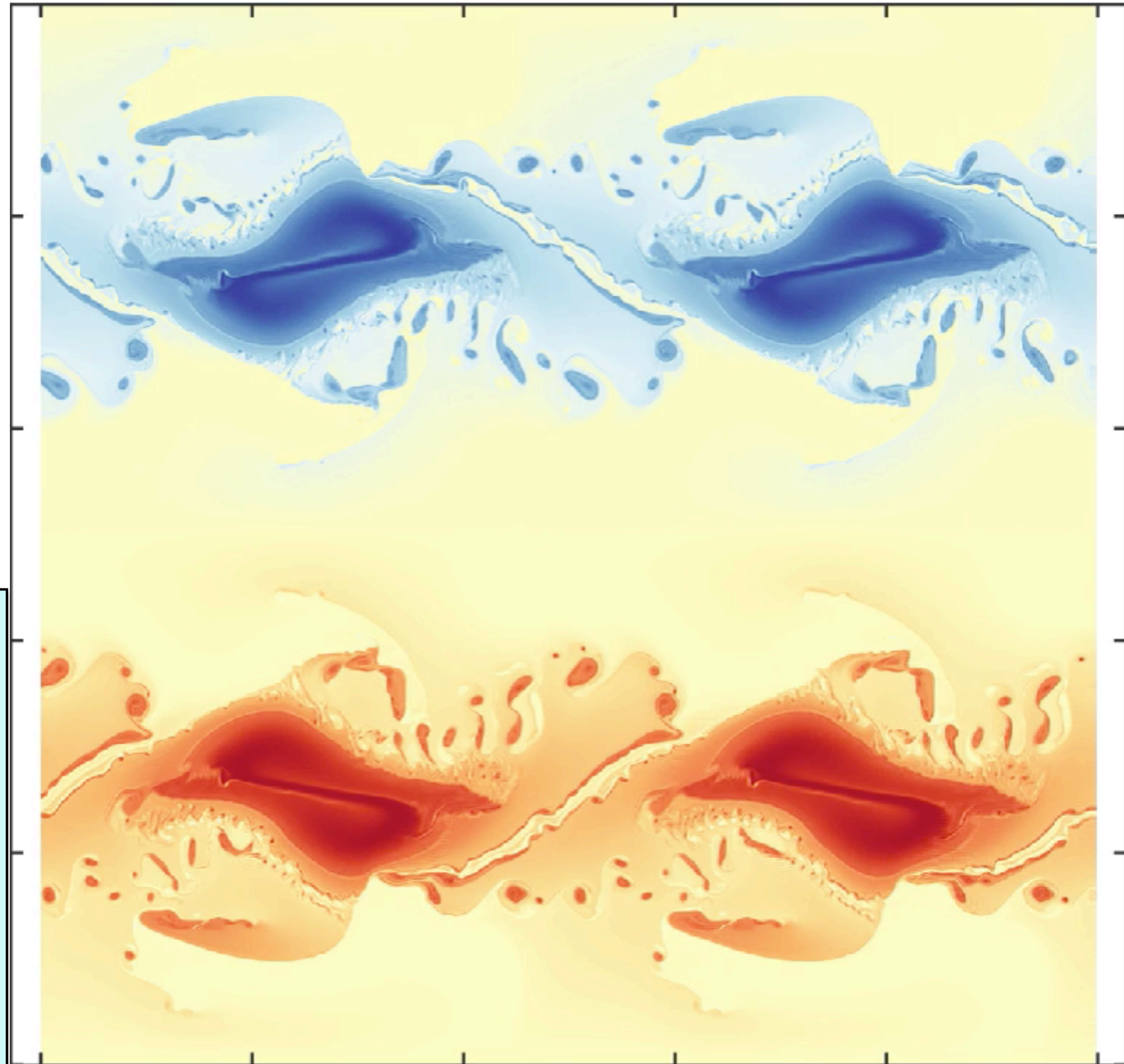

$t = 17$ day

SQG

$$\frac{Db}{Dt} = -\alpha_{HV} \Delta^4 b \quad \text{Hyper-viscosity}$$

$$\mathbf{u} = \left(\text{cst.} \nabla^\perp \Delta^{-\frac{1}{2}} \right) b$$

Reference flow:

deterministic

SQG

1024 x 1024

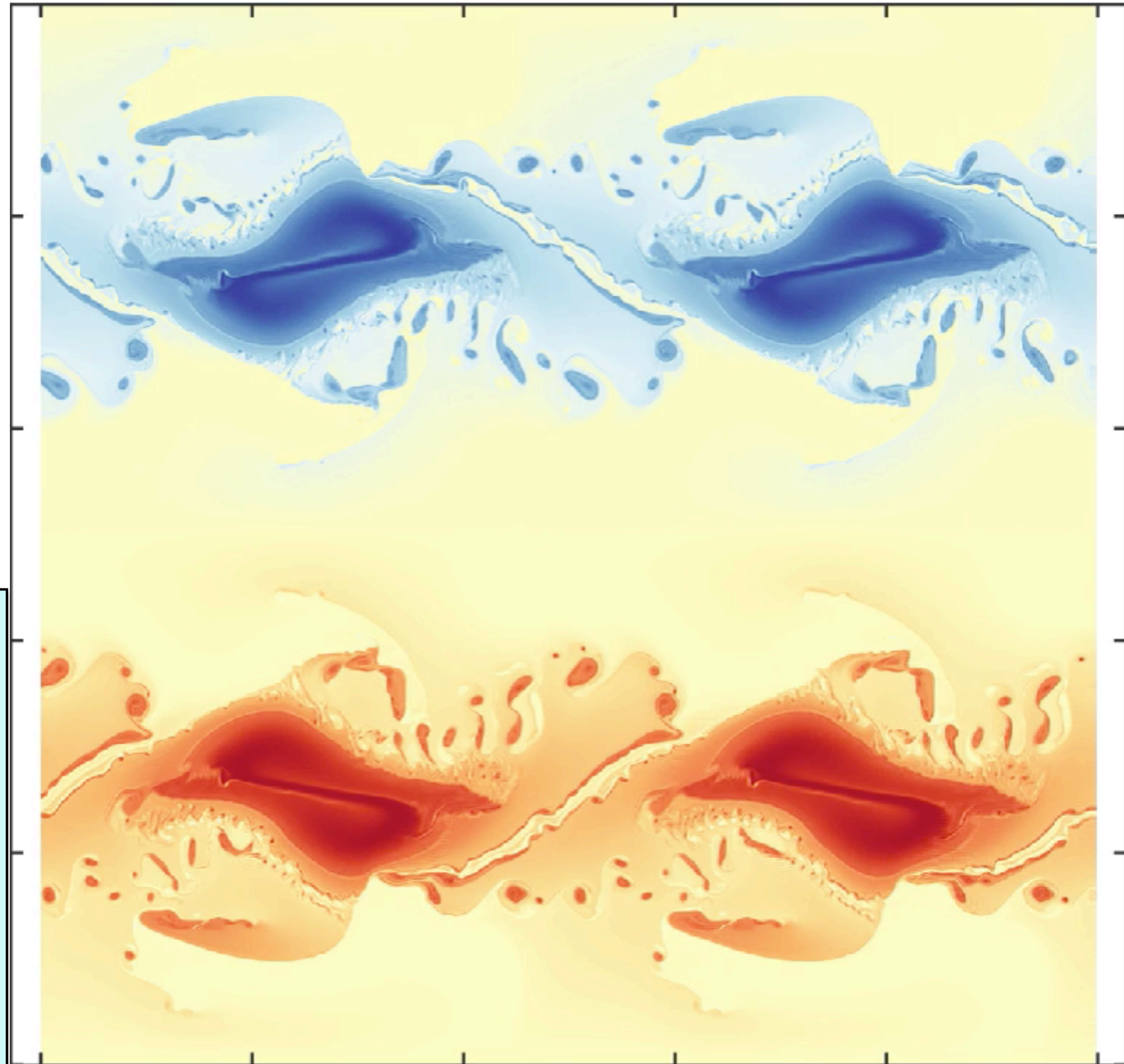

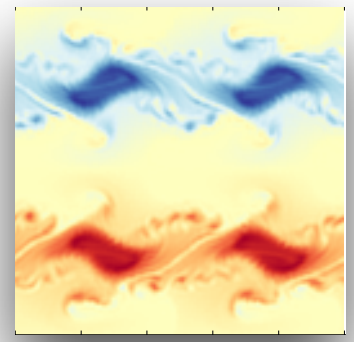

One realization : Stochastic destabilization

Deterministic 128 x 128

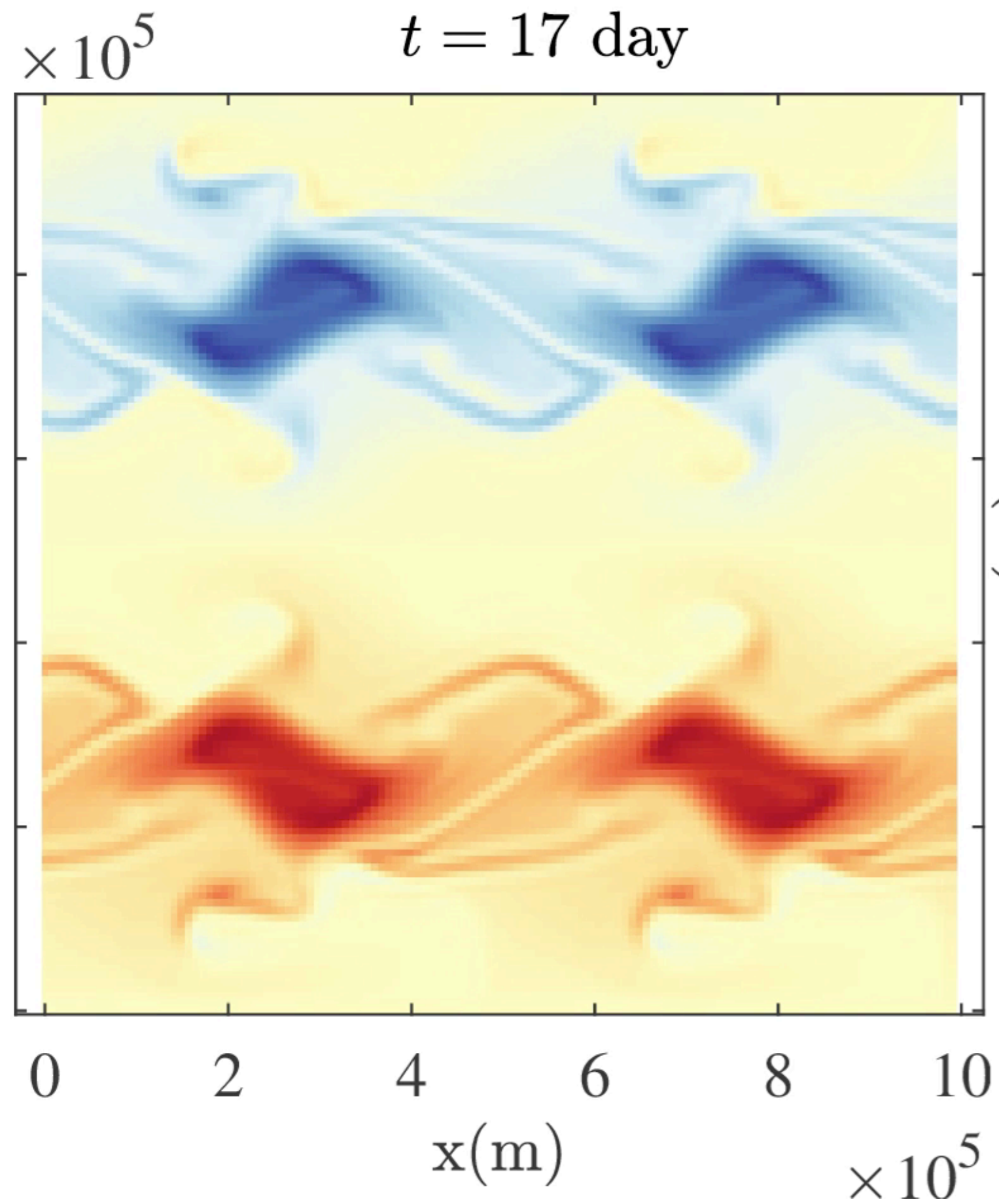

Deterministic 1024 x 1024

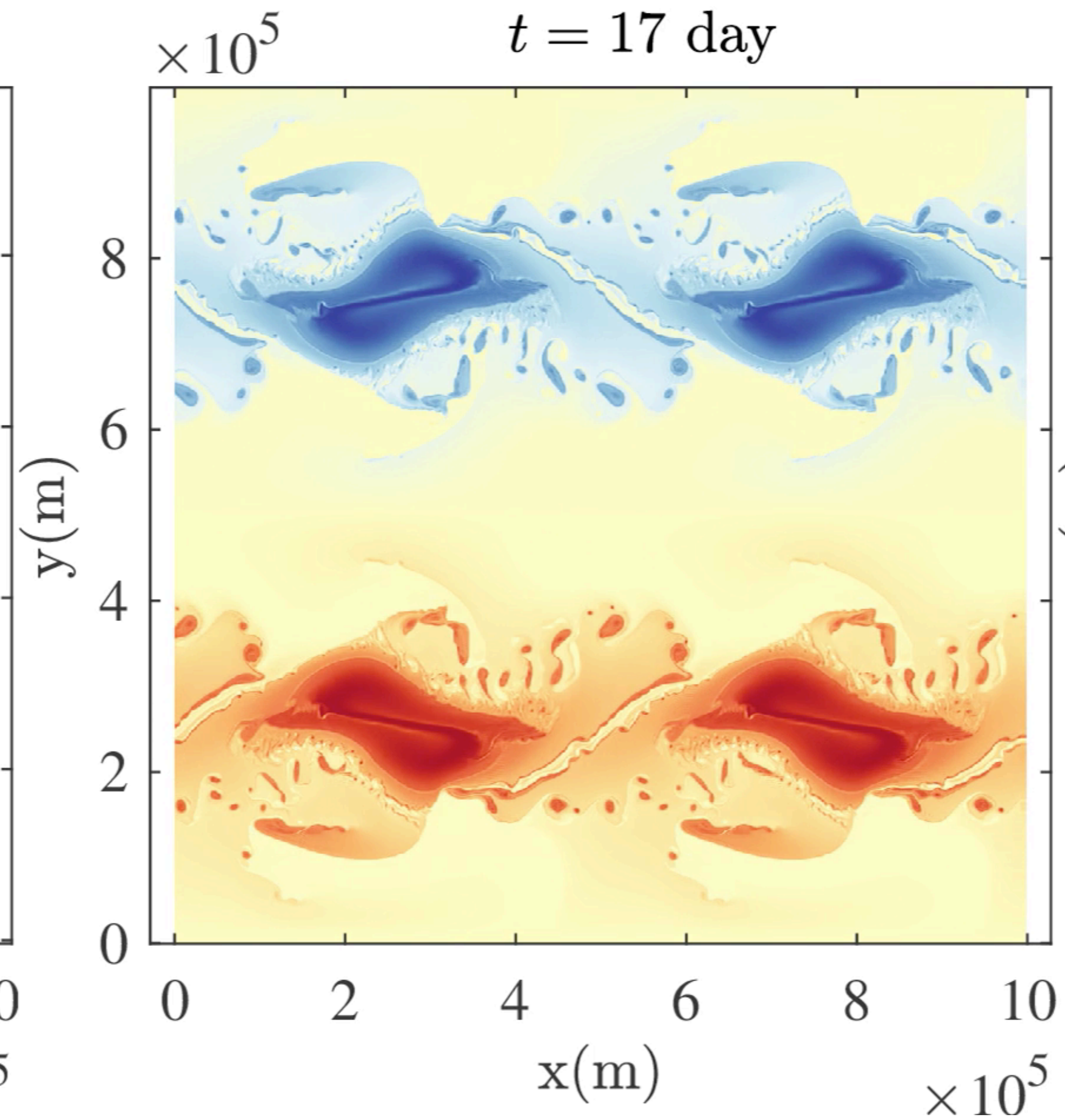

Location Uncertainty 128 x 128

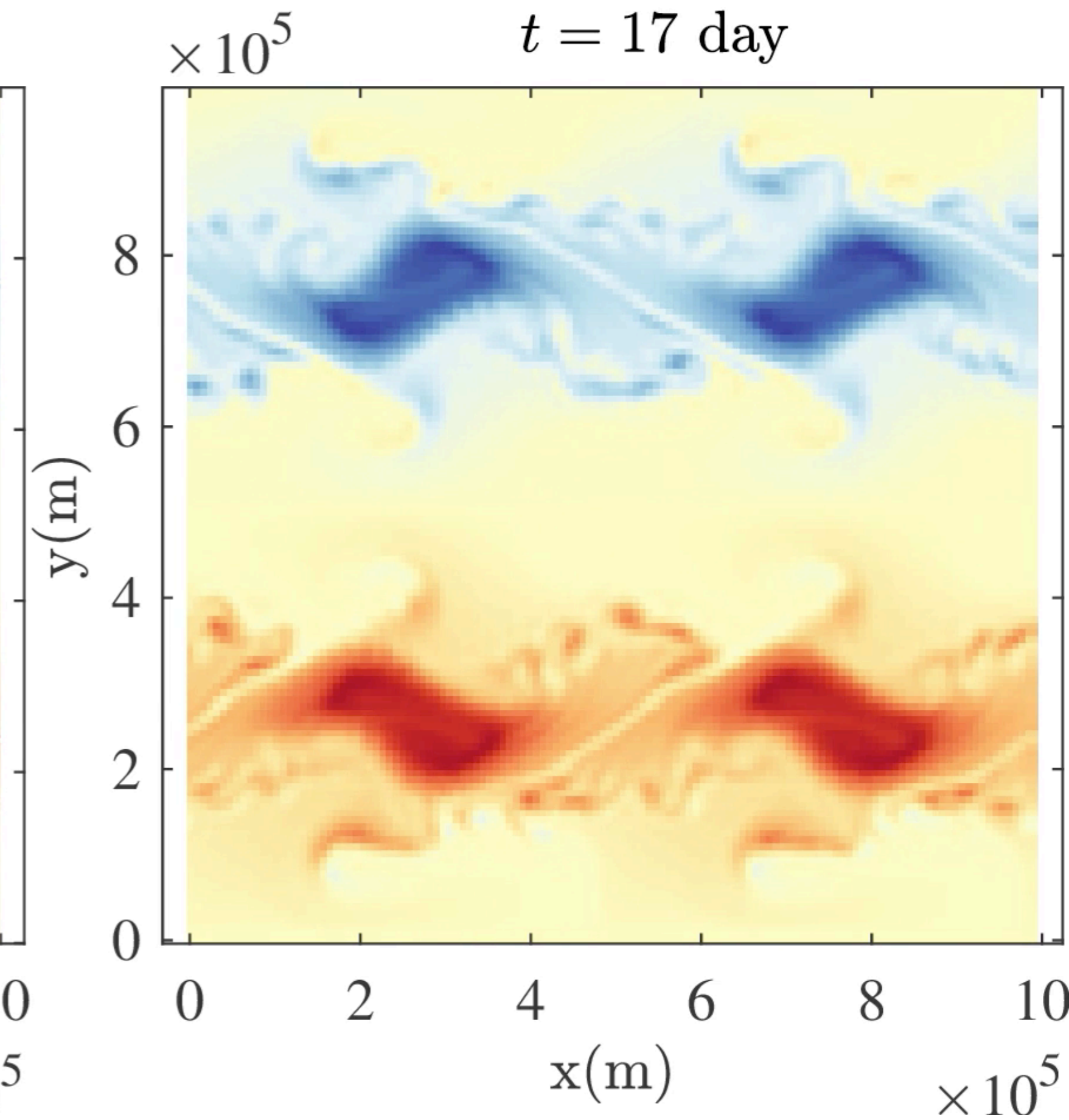

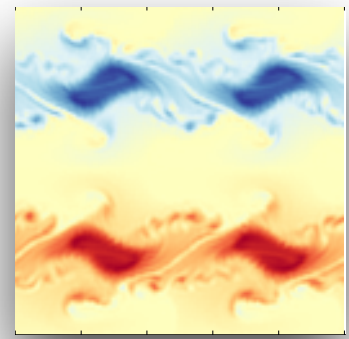

One realization : Stochastic destabilization

Deterministic 128 x 128

Deterministic 1024 x 1024

Location Uncertainty 128 x 128

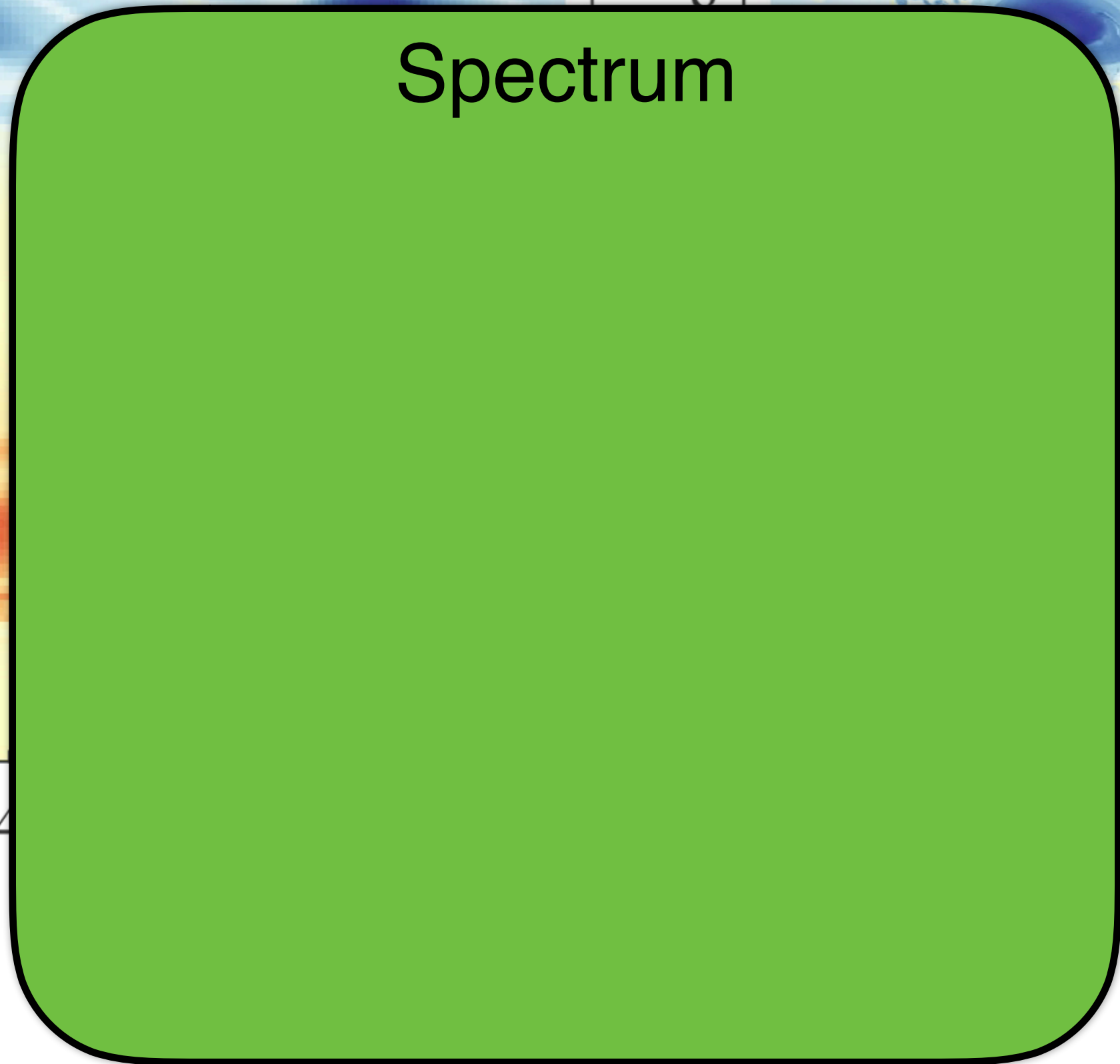
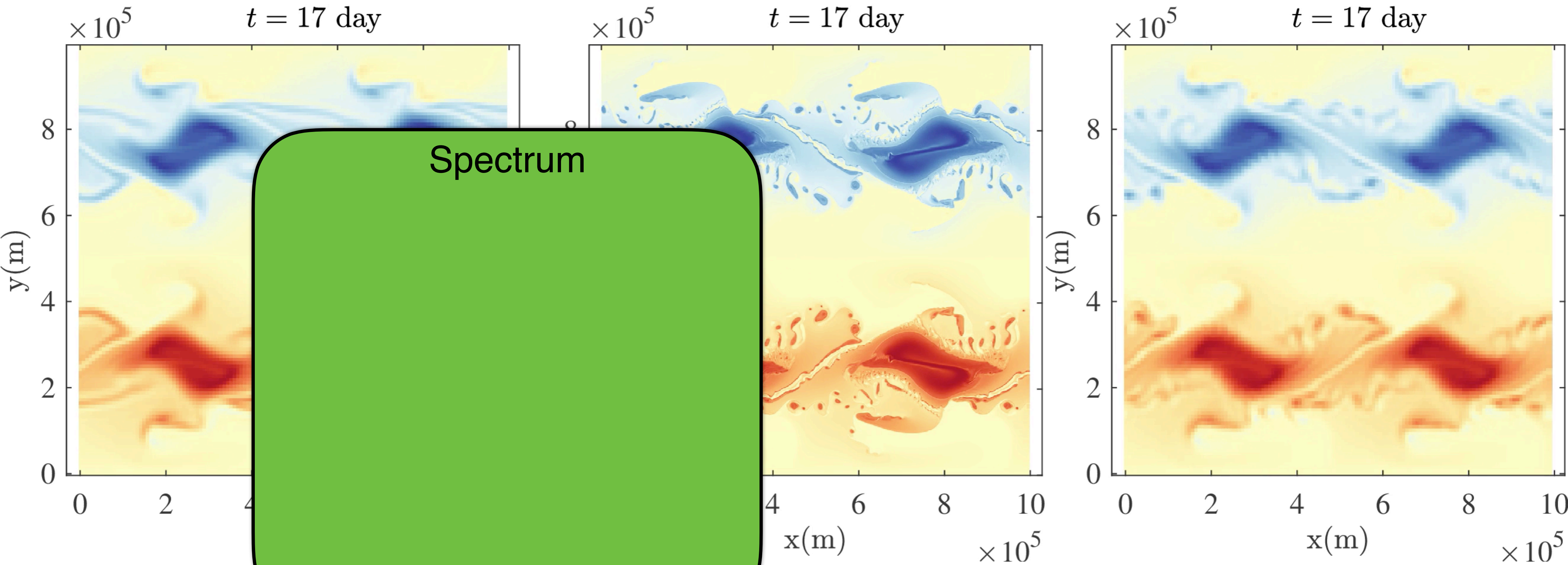

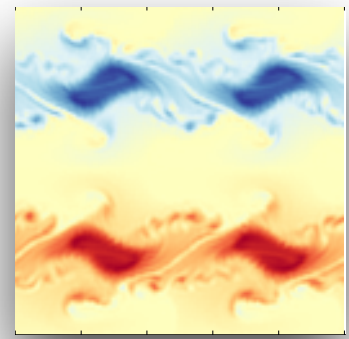

One realization : Stochastic destabilization

Deterministic 128 x 128

Deterministic 1024 x 1024

Location Uncertainty 128 x 128

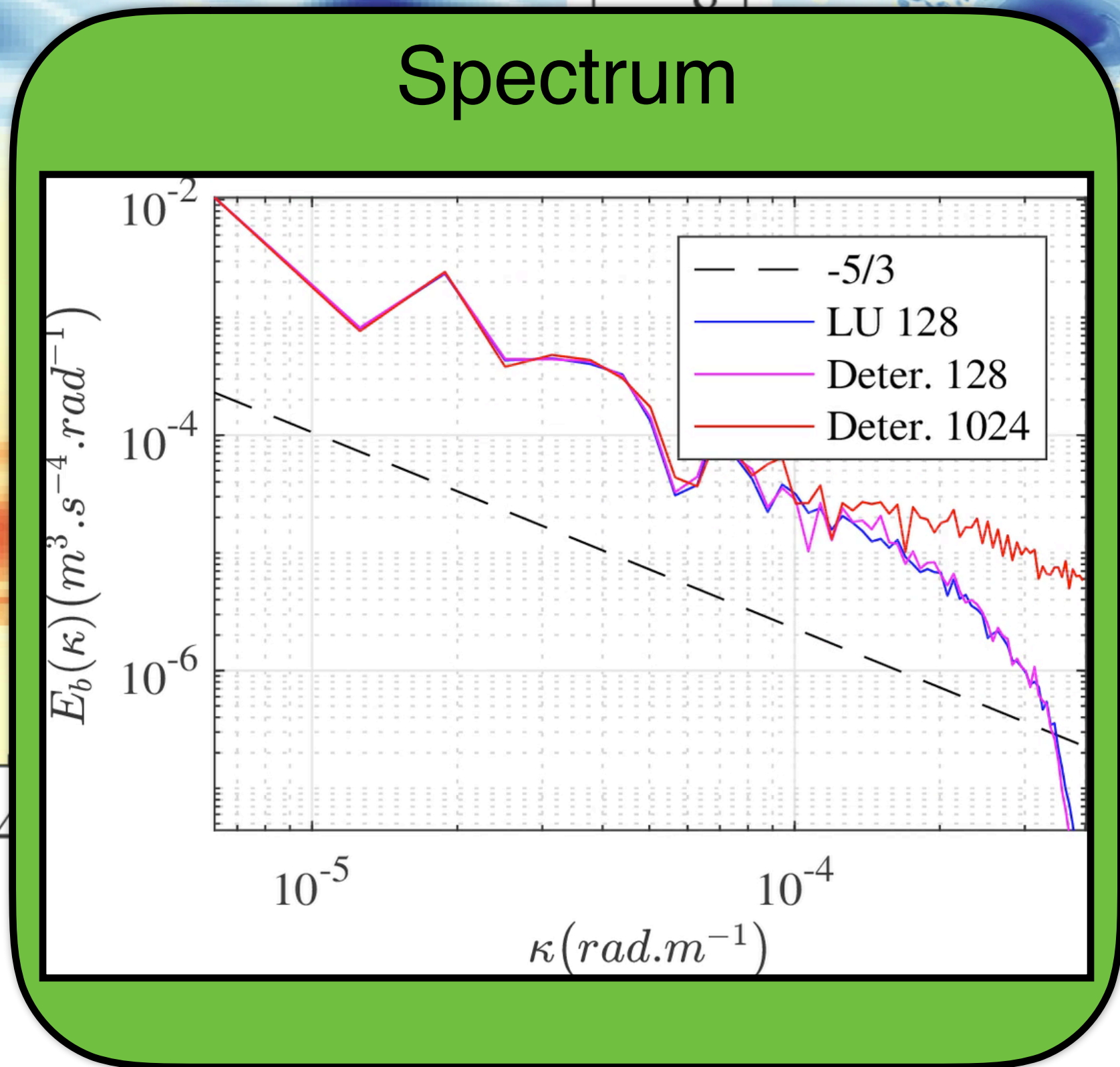
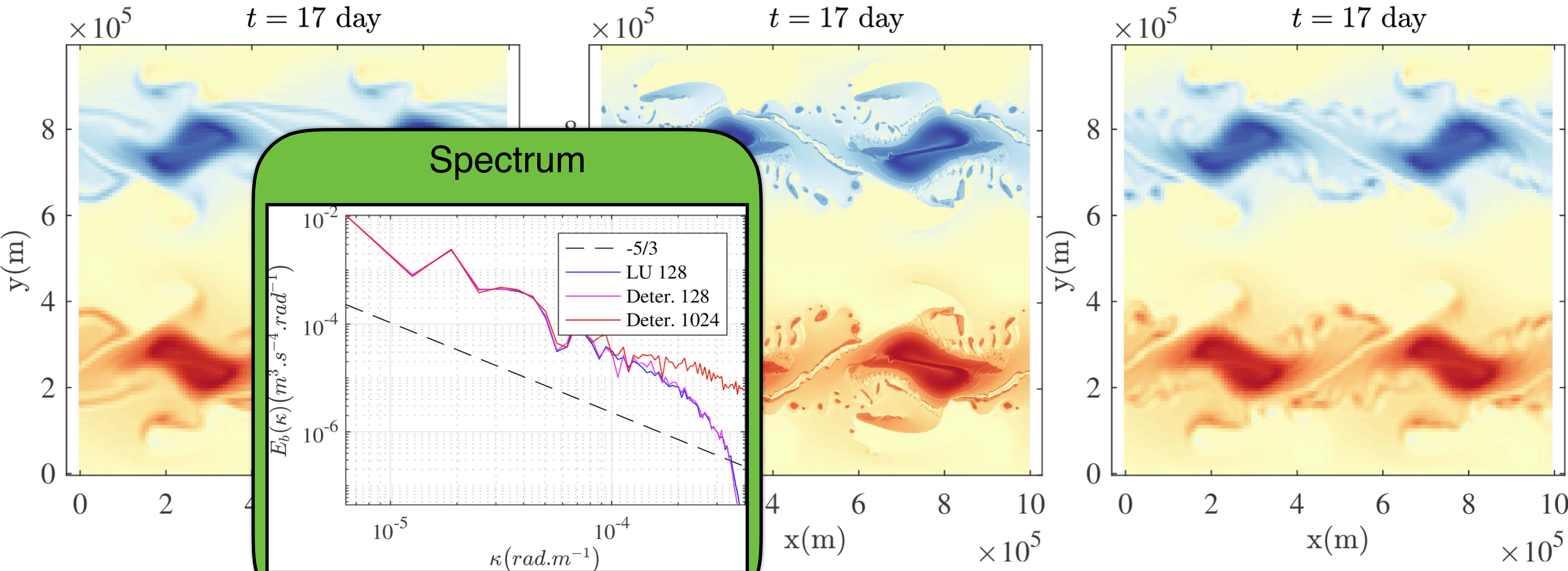

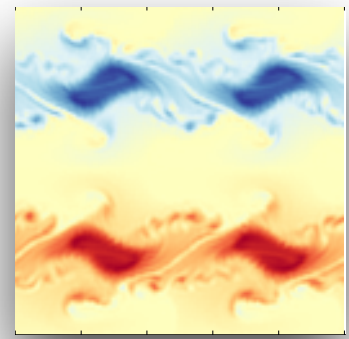

One realization : Stochastic destabilization

Deterministic 128 x 128

Deterministic 1024 x 1024

Location Uncertainty 128 x 128

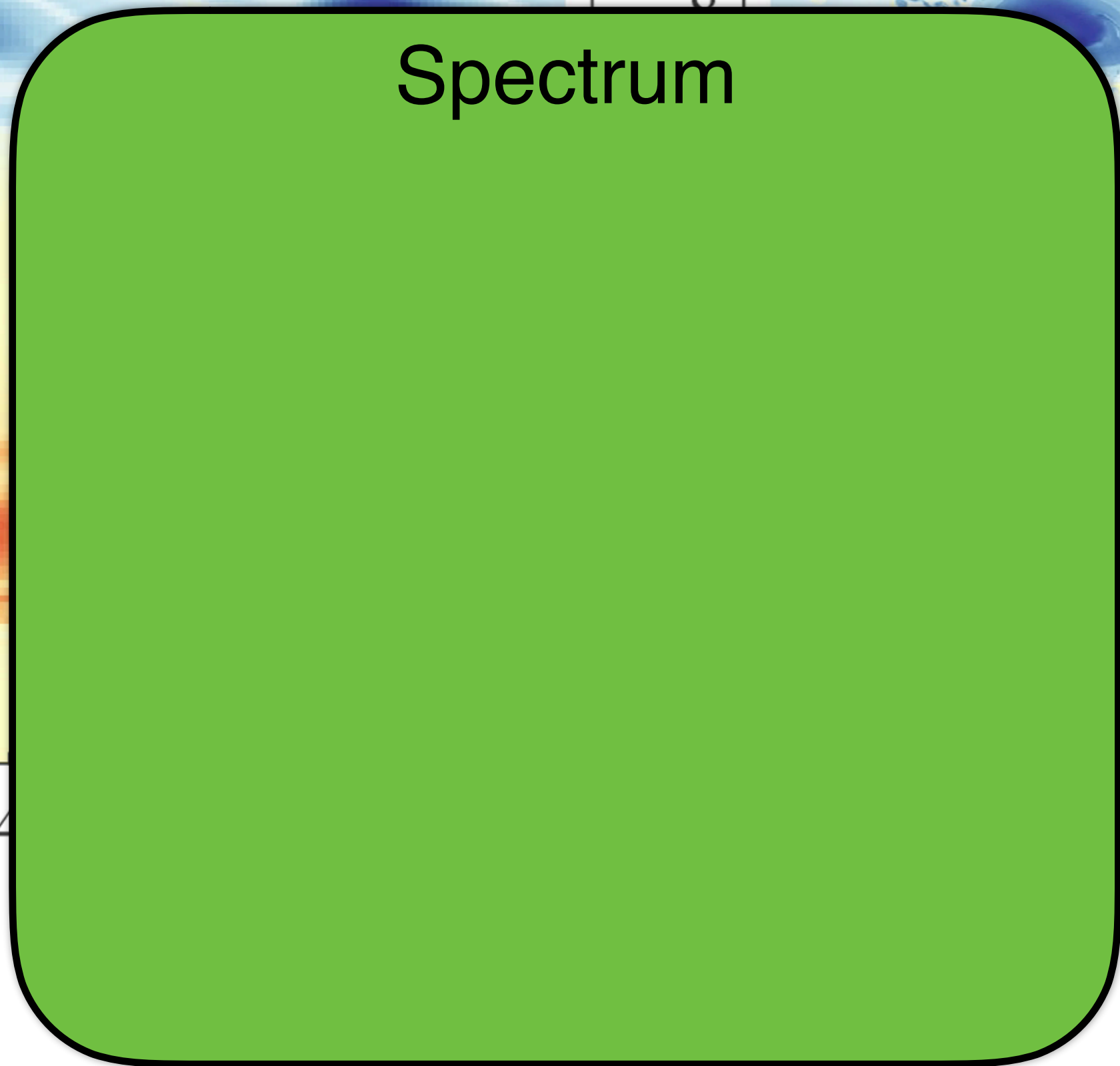
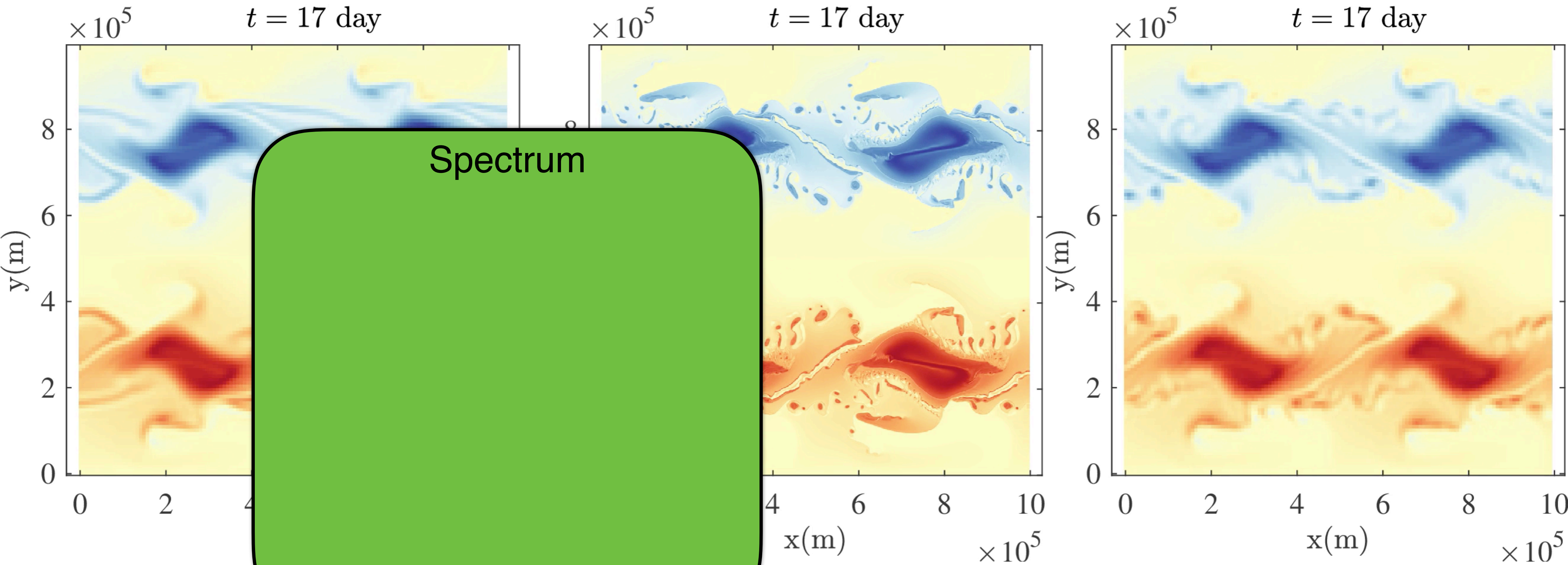

Spectrum

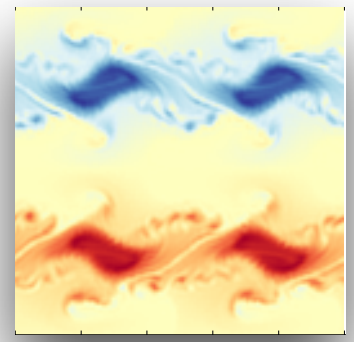

One realization : Stochastic destabilization

Deterministic 128 x 128

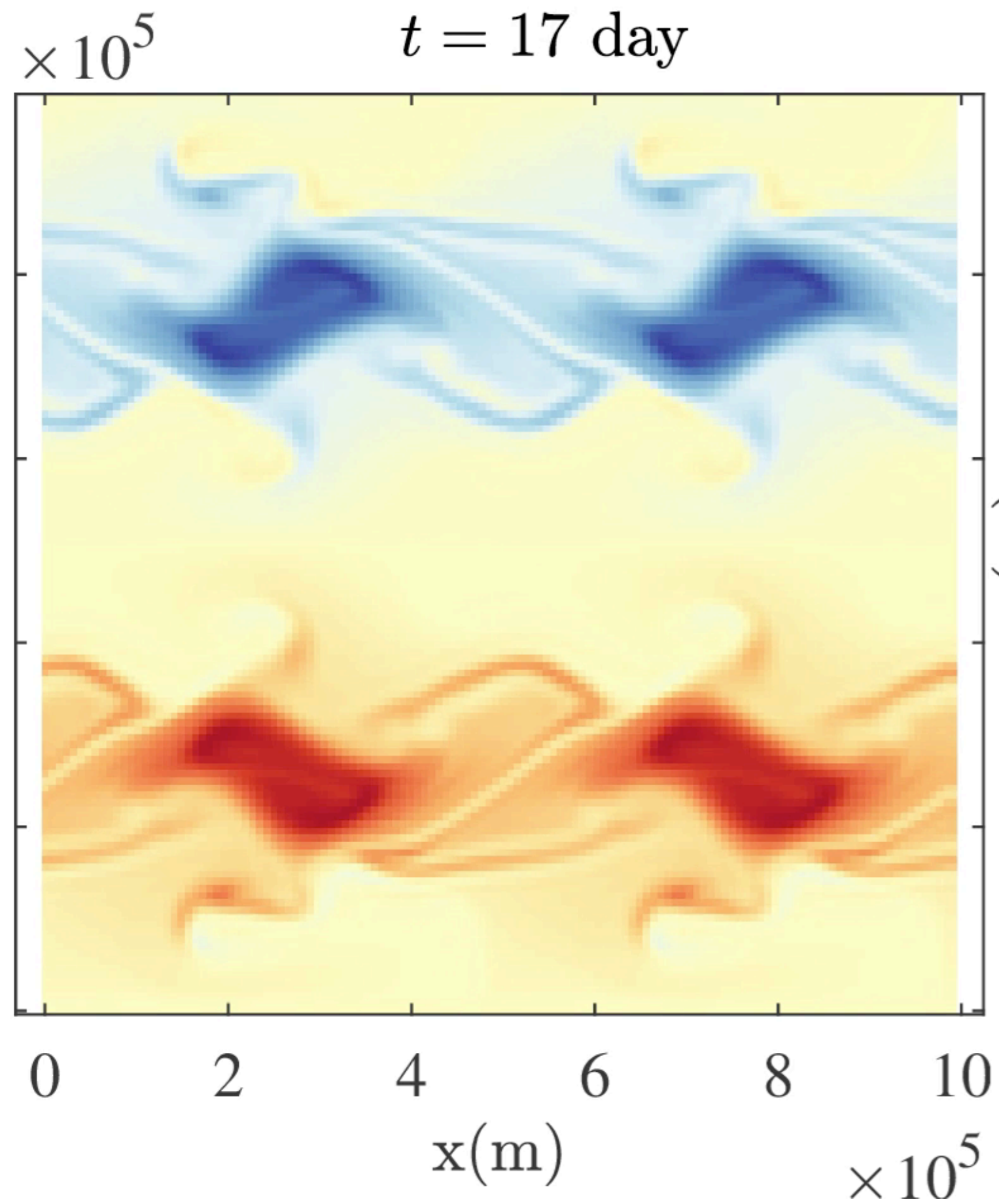

Deterministic 1024 x 1024

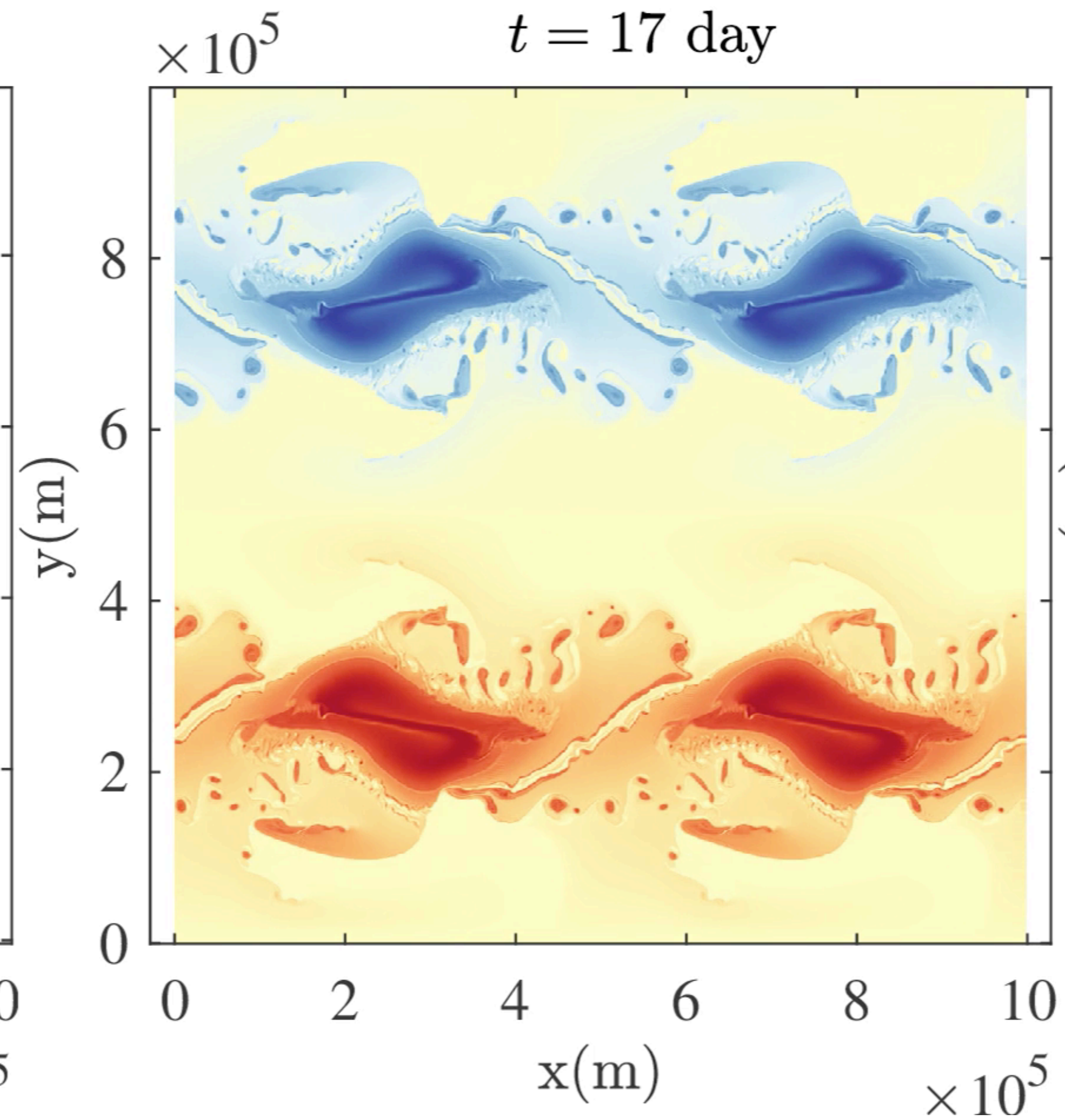

Location Uncertainty 128 x 128

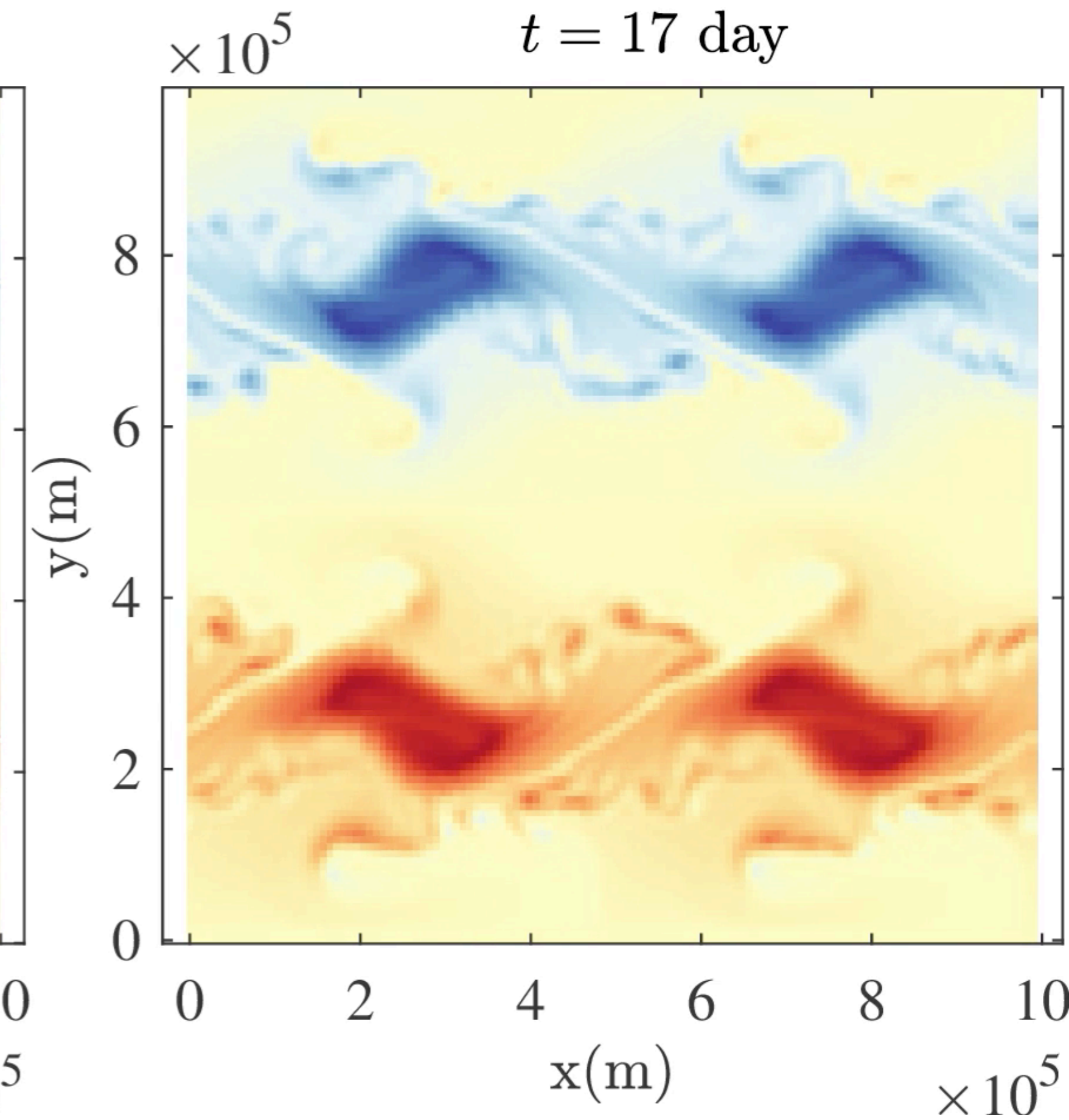

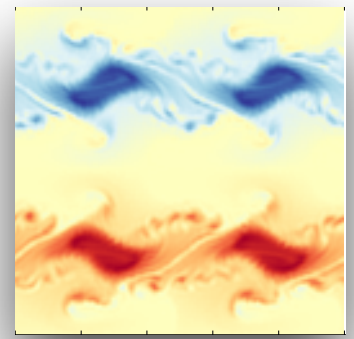

One realization : Stochastic destabilization

Deterministic 128 x 128

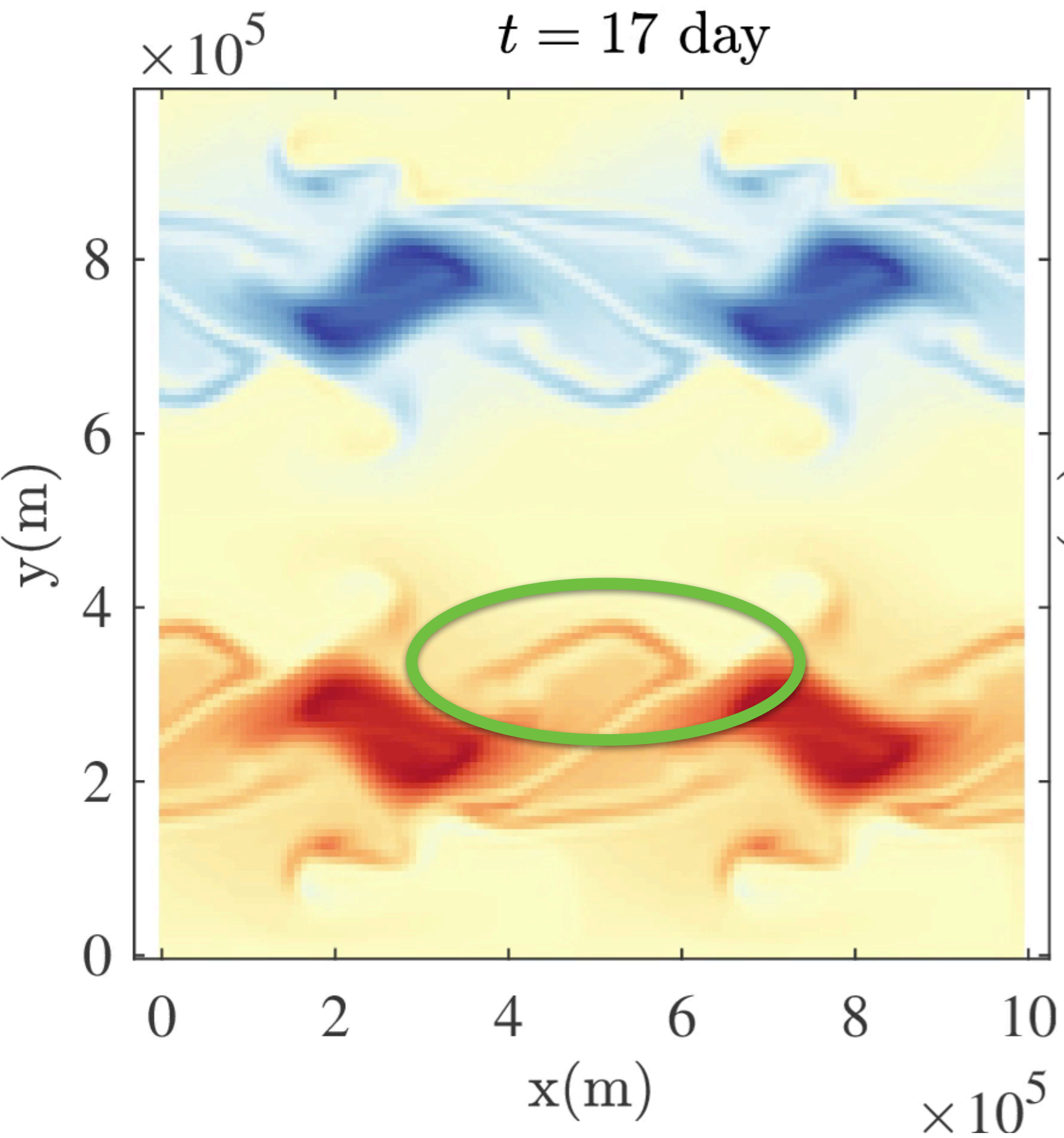

Deterministic 1024 x 1024

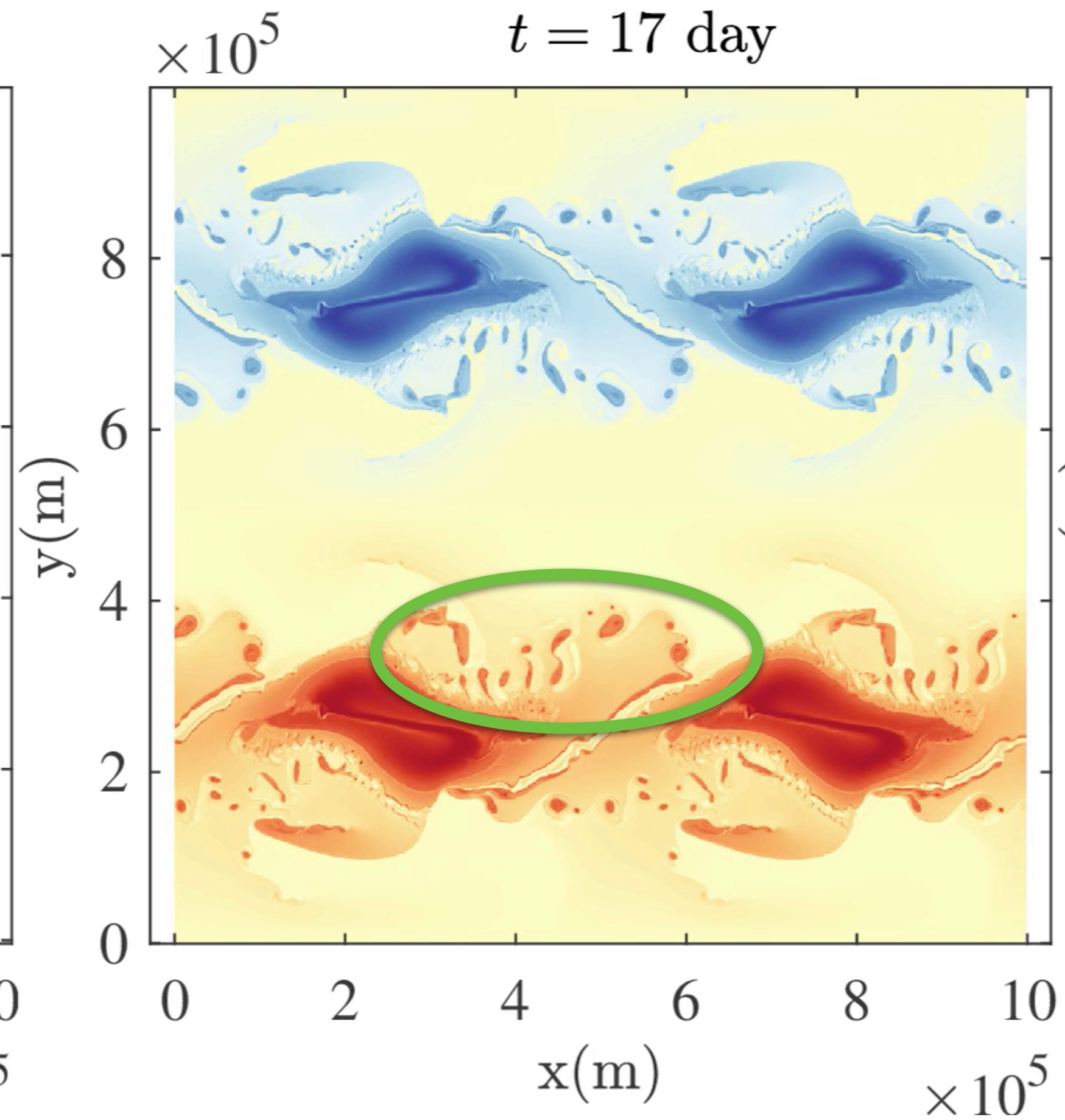

Location Uncertainty 128 x 128

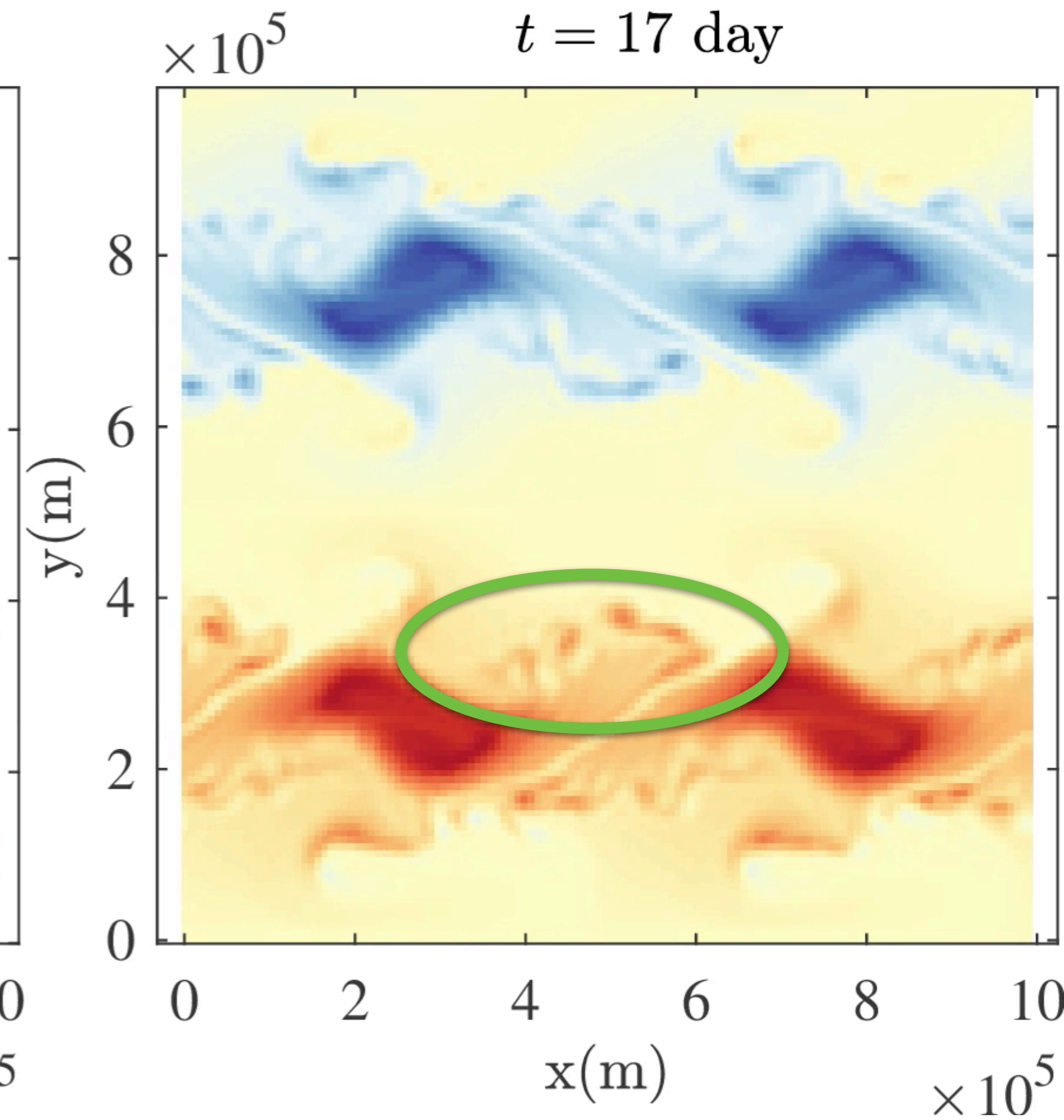

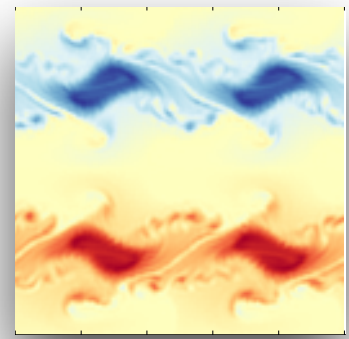

One realization : Stochastic destabilization

Deterministic 128 x 128

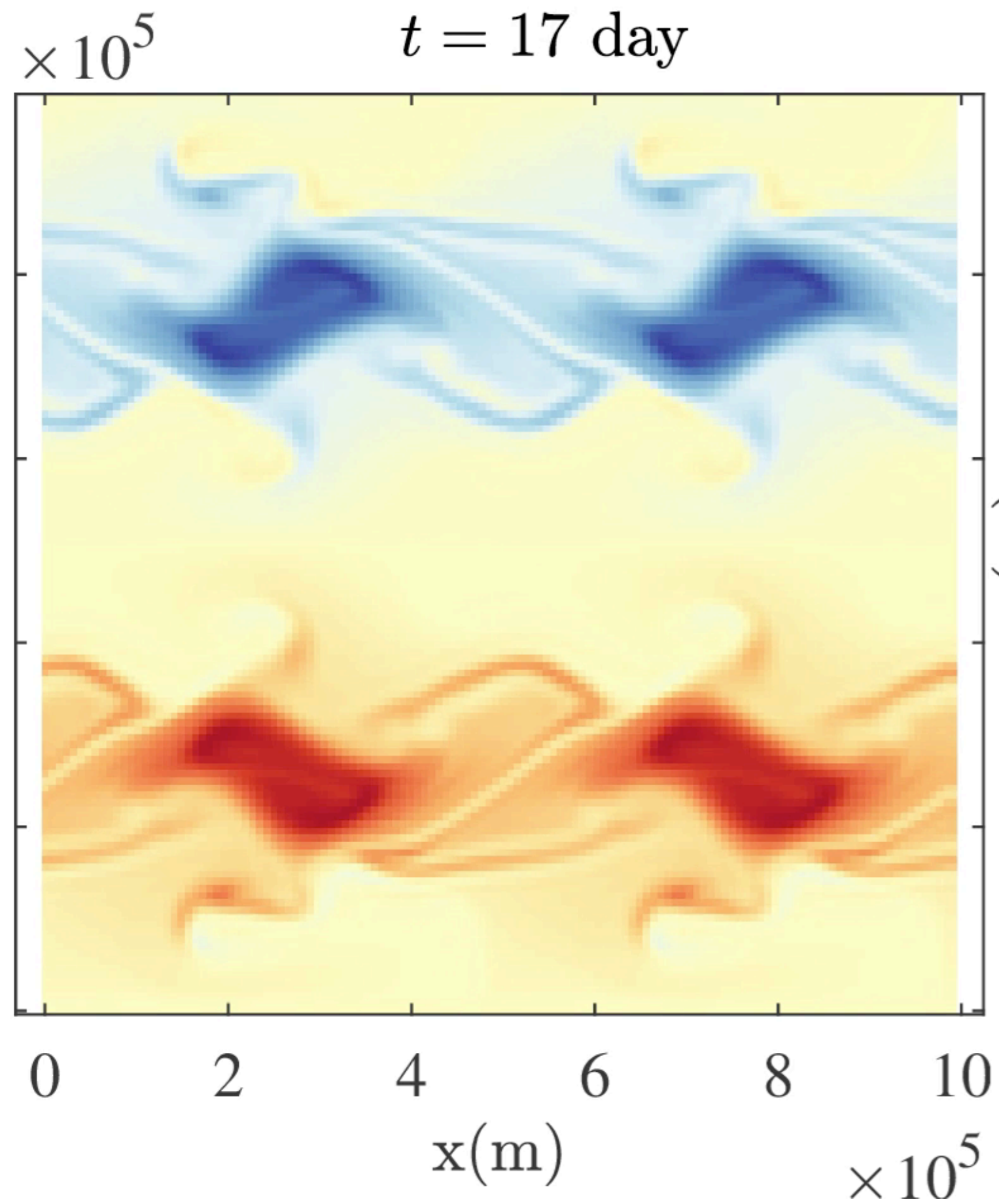

Deterministic 1024 x 1024

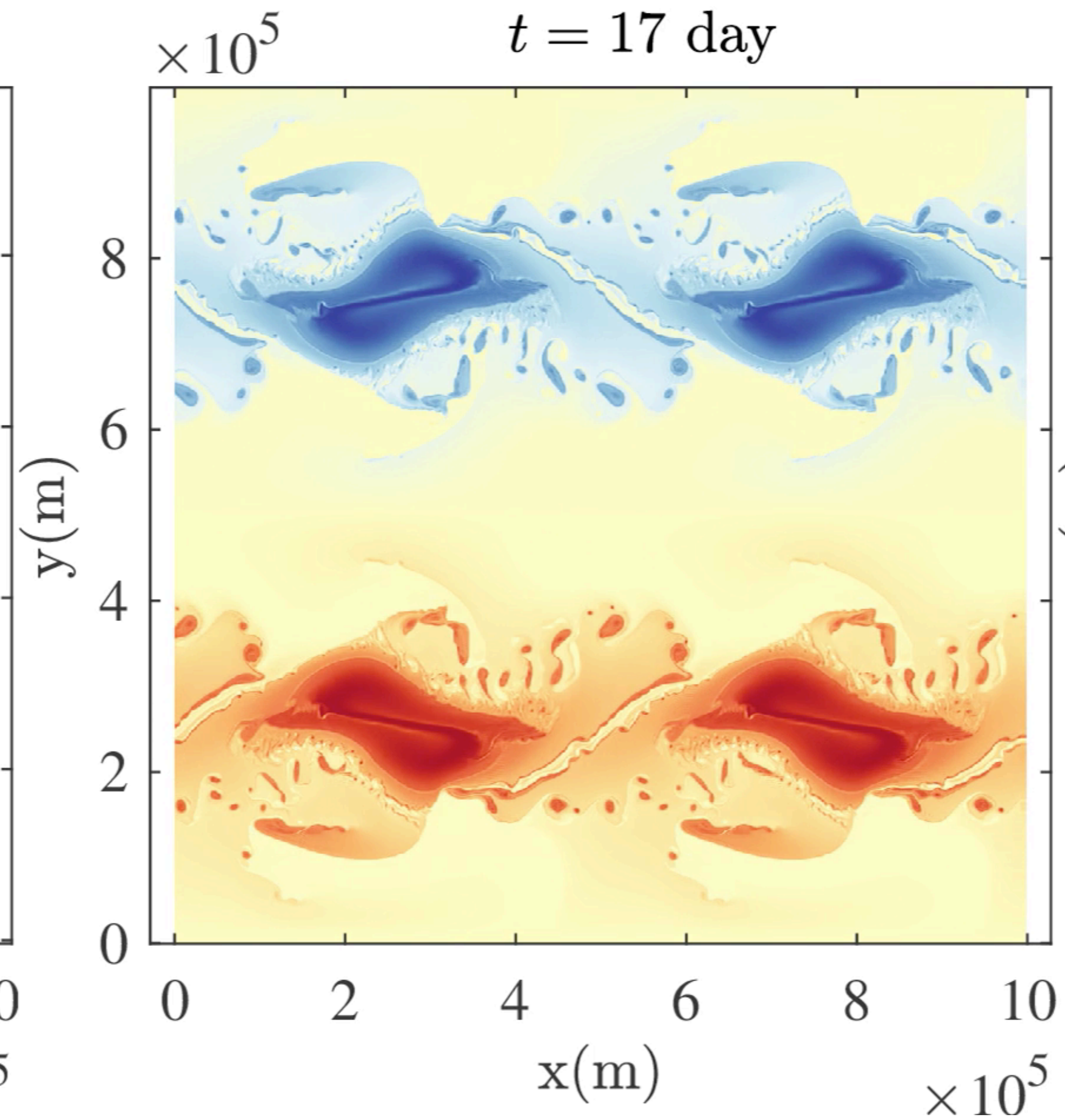

Location Uncertainty 128 x 128

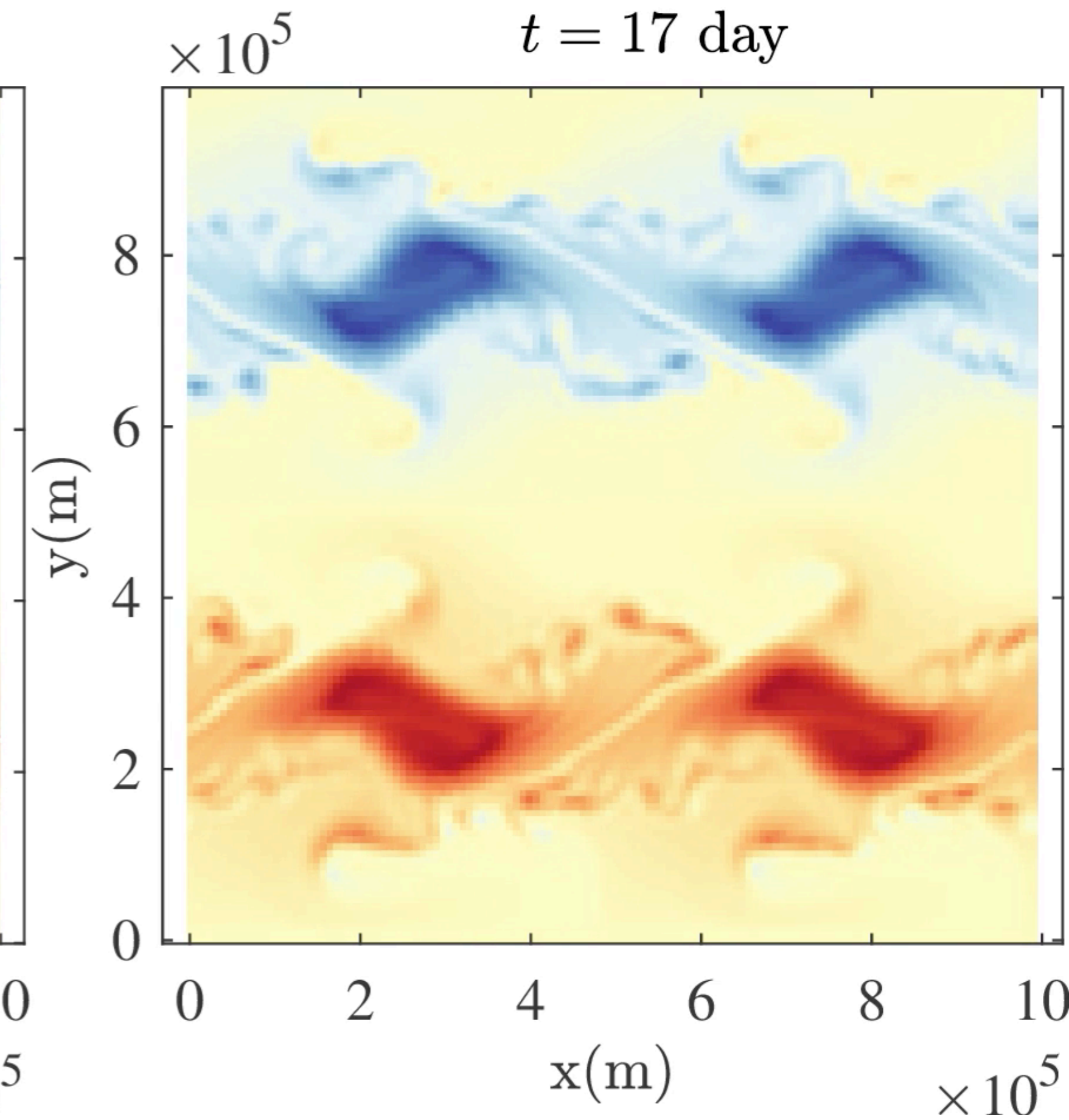

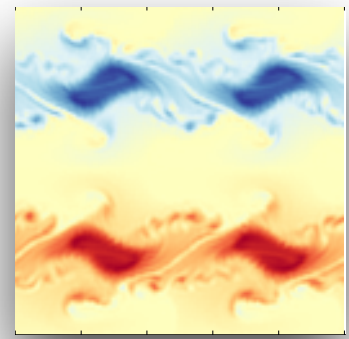

One realization : Stochastic destabilization

Deterministic 128 x 128

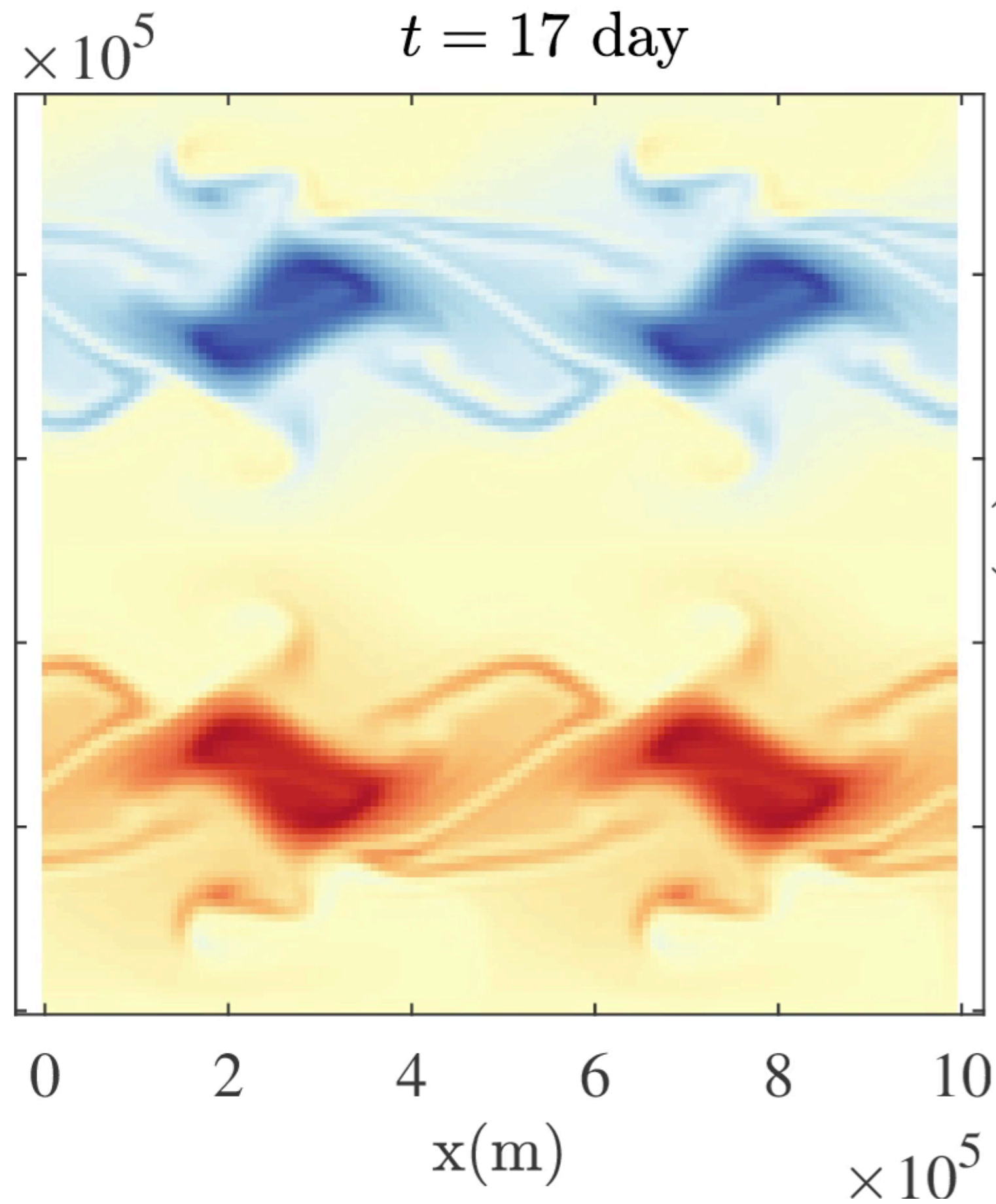

Deterministic 1024 x 1024

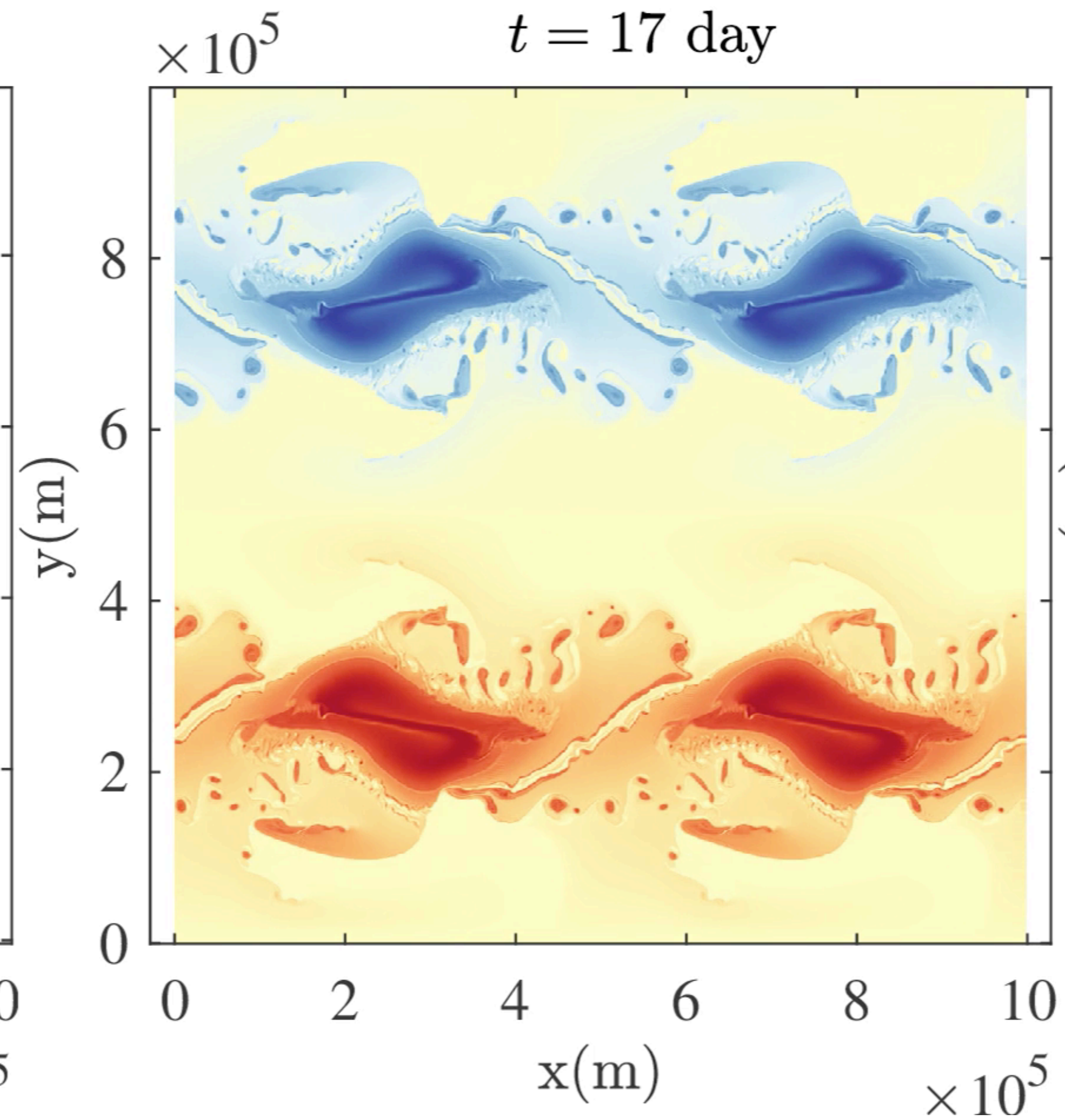

Location Uncertainty 128 x 128

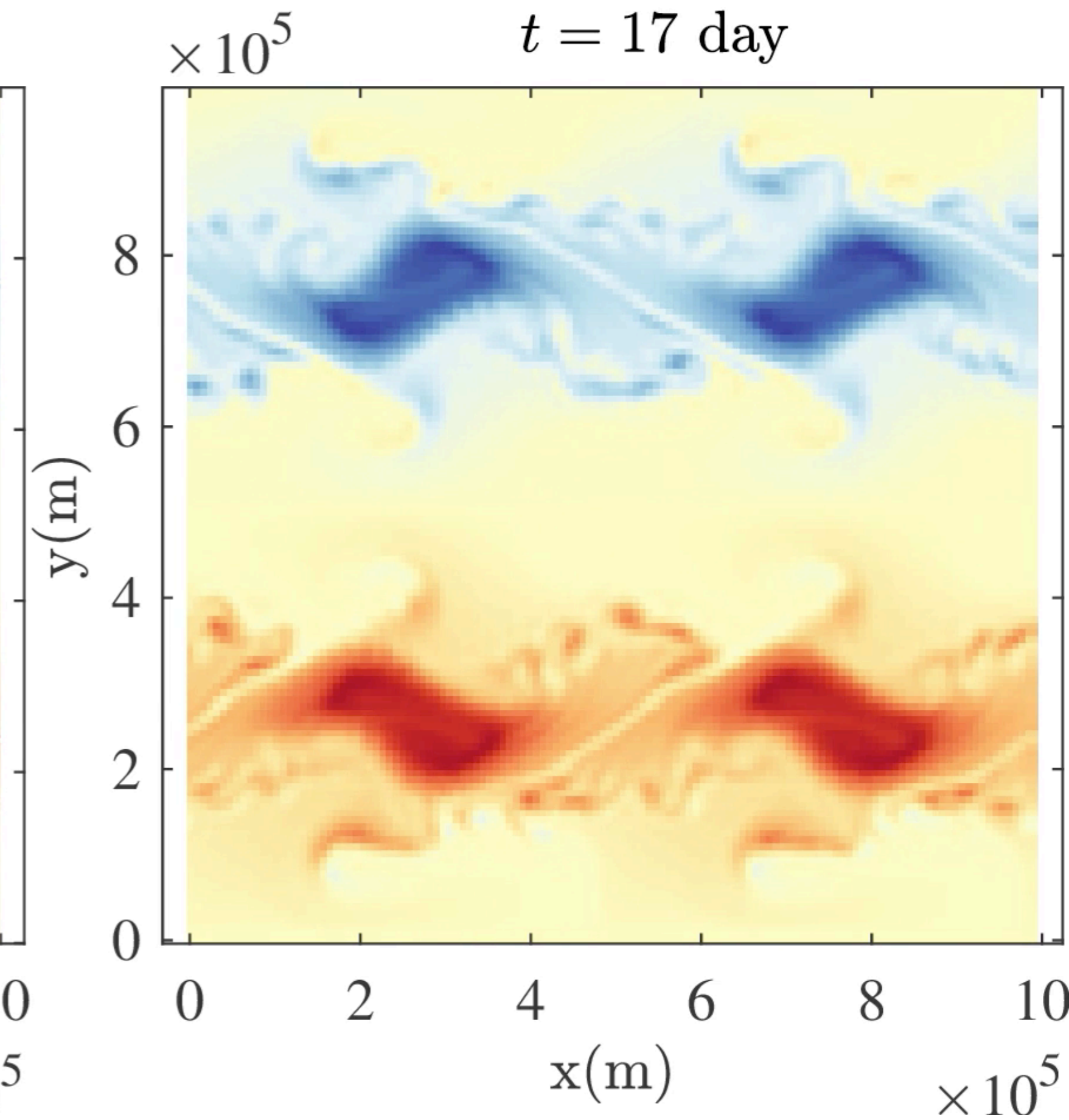

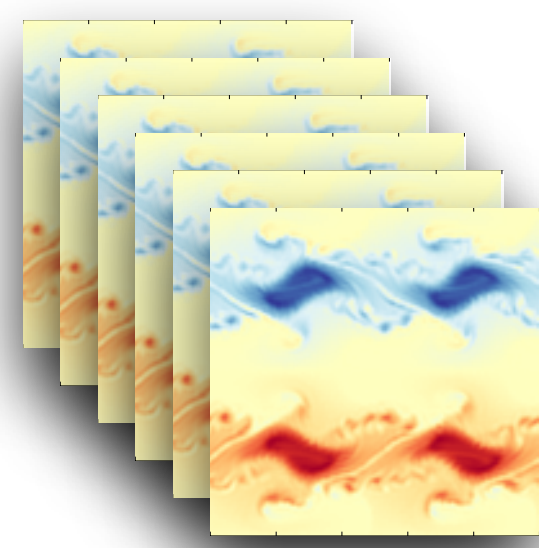

Ensemble: random coherent structures

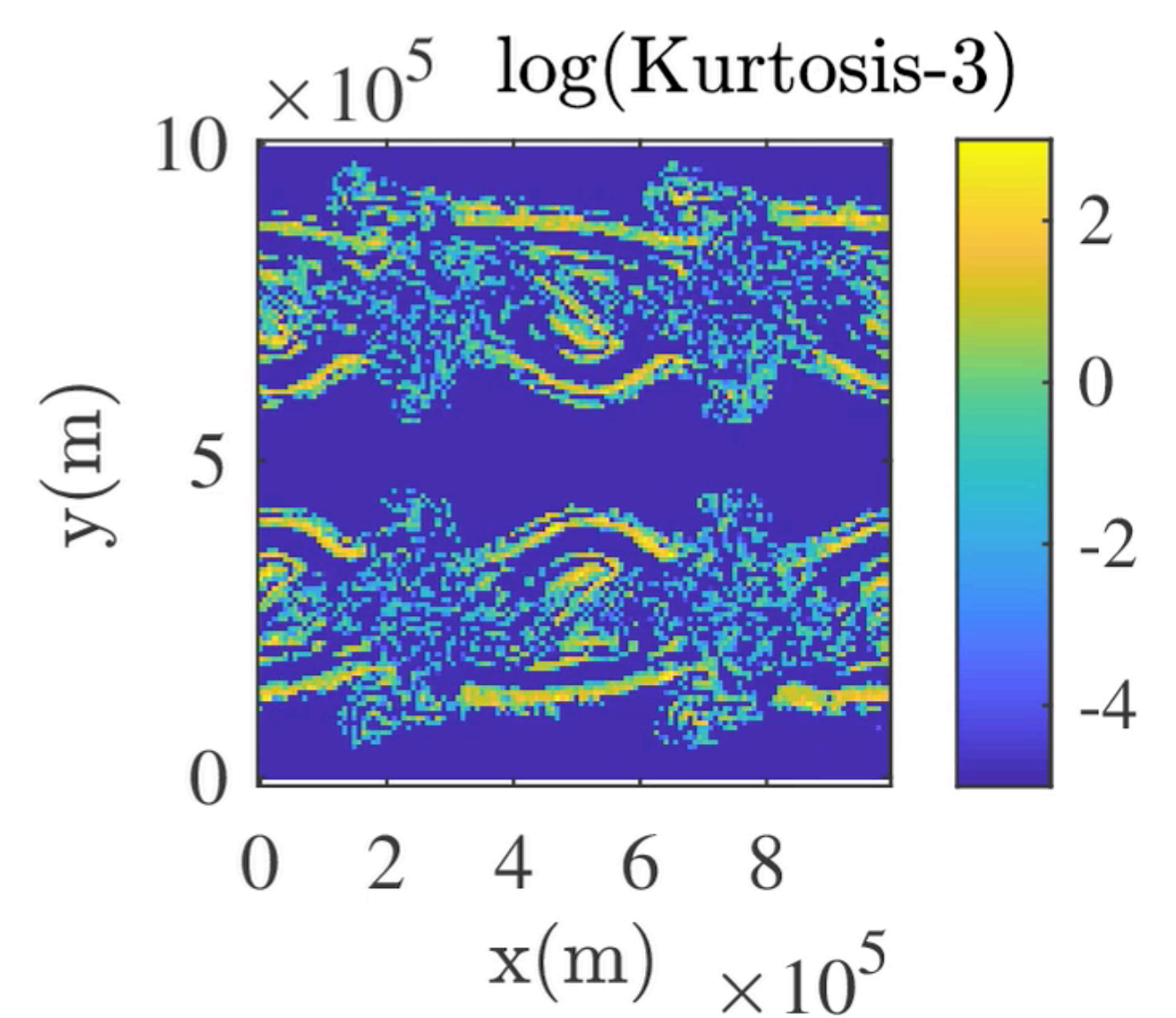
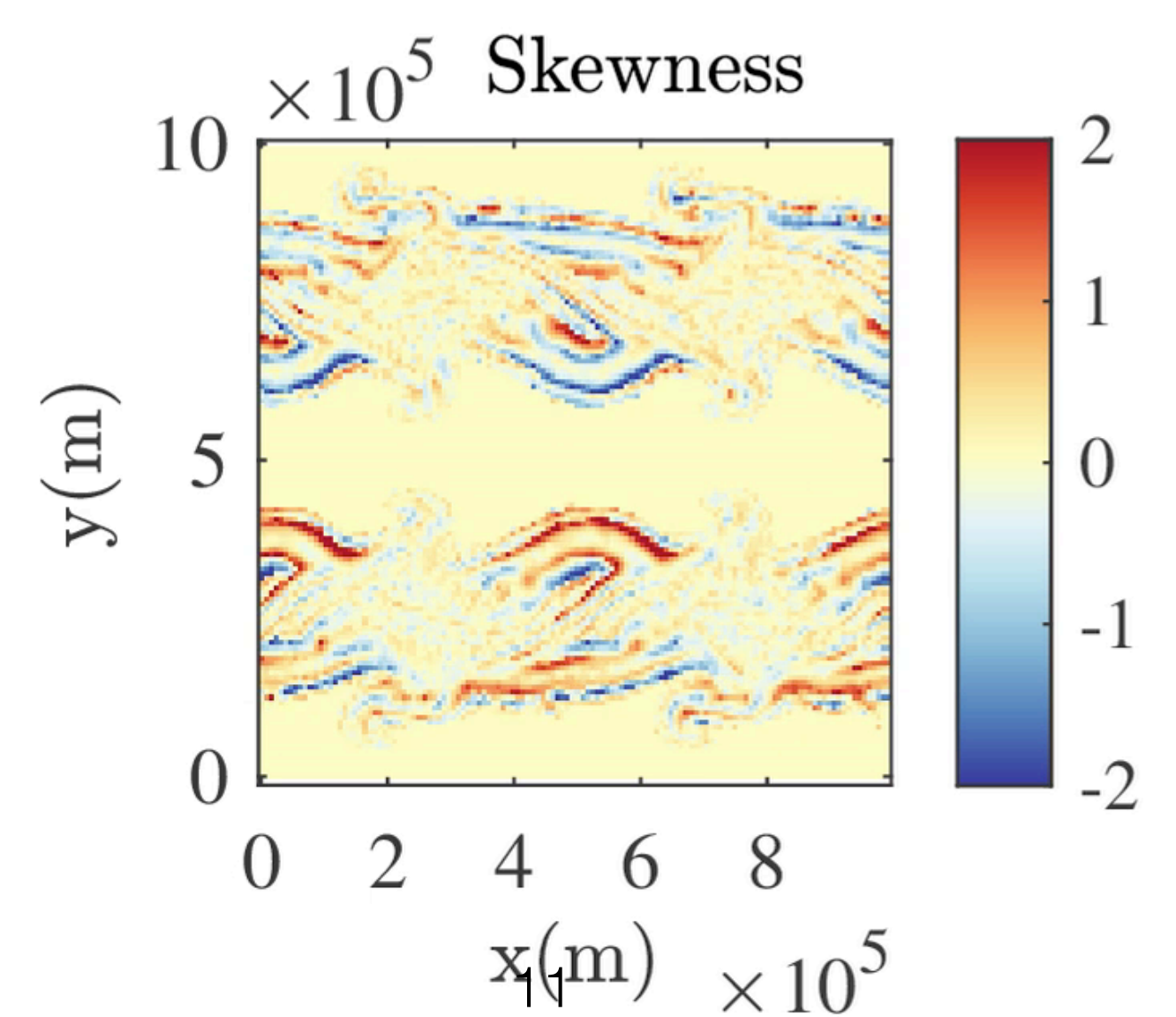
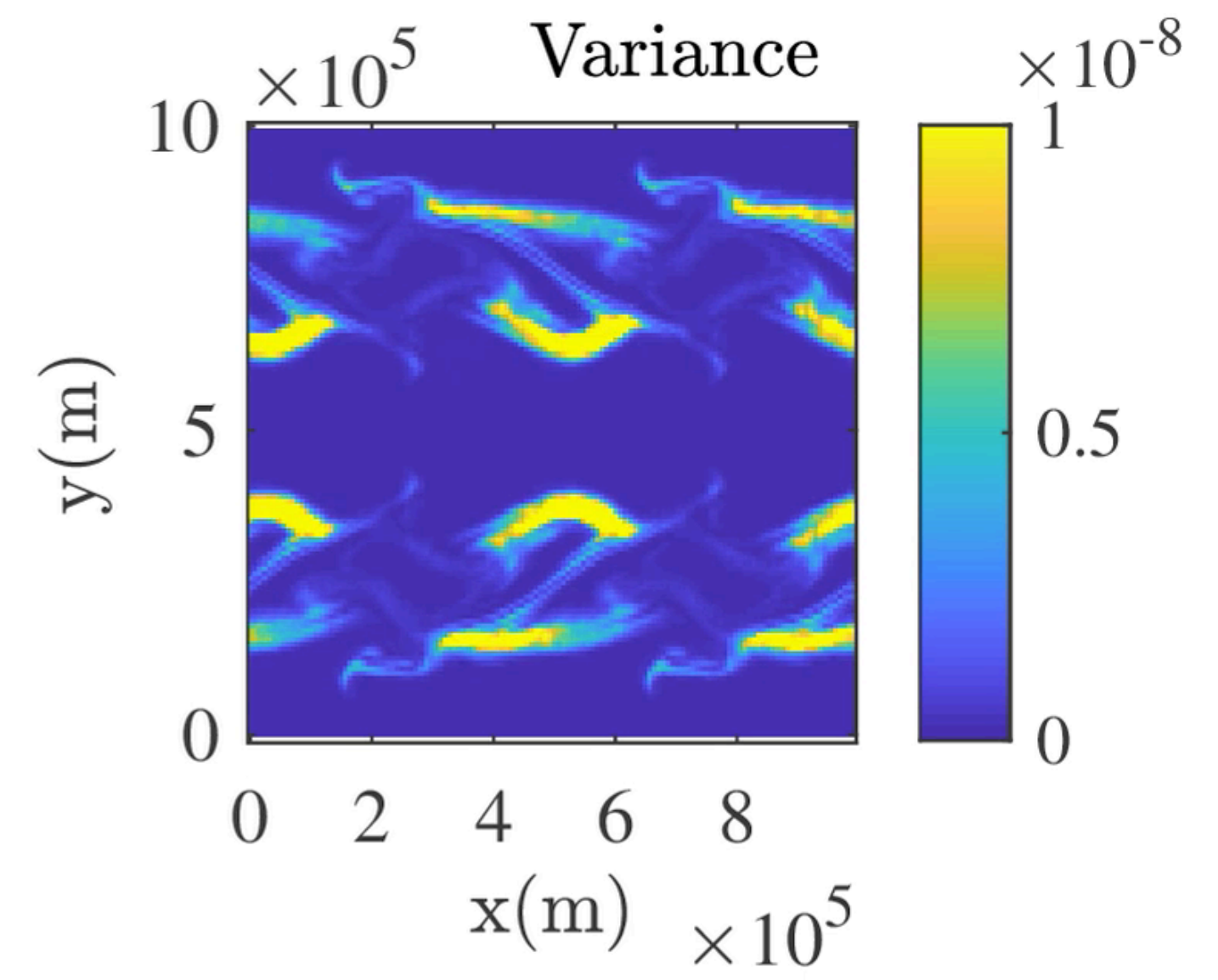
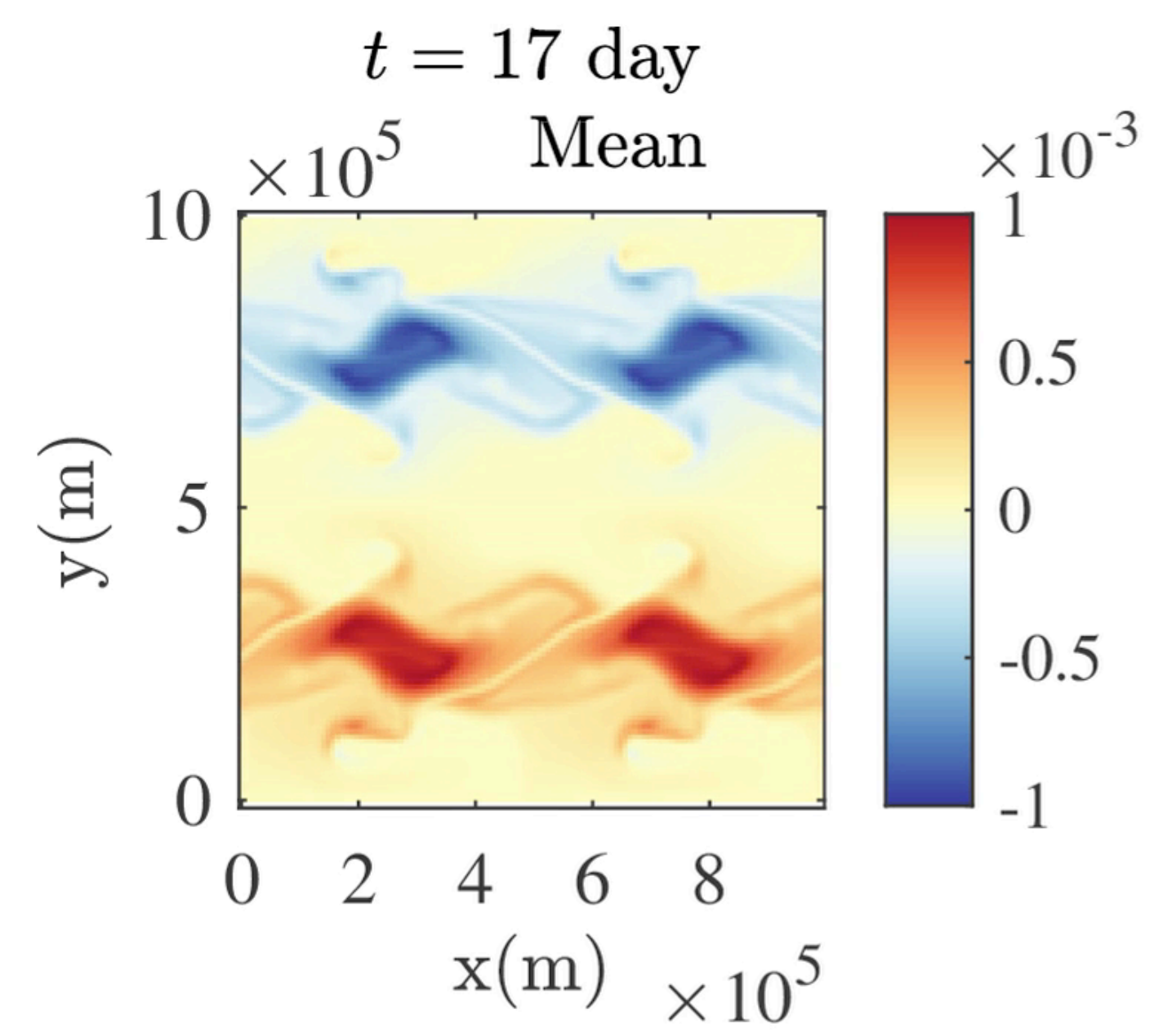

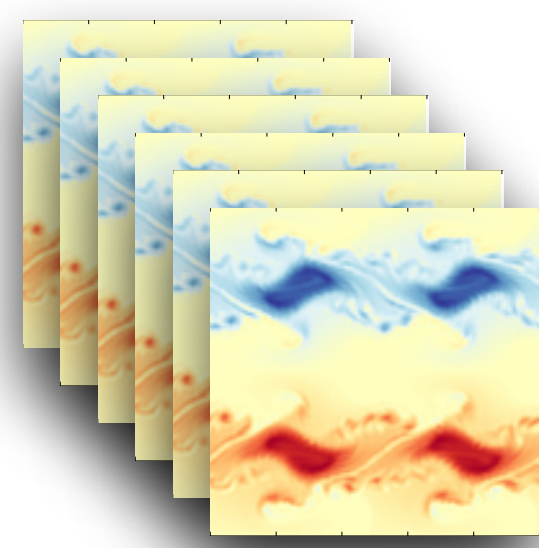

Ensemble:
random
coherent
structures

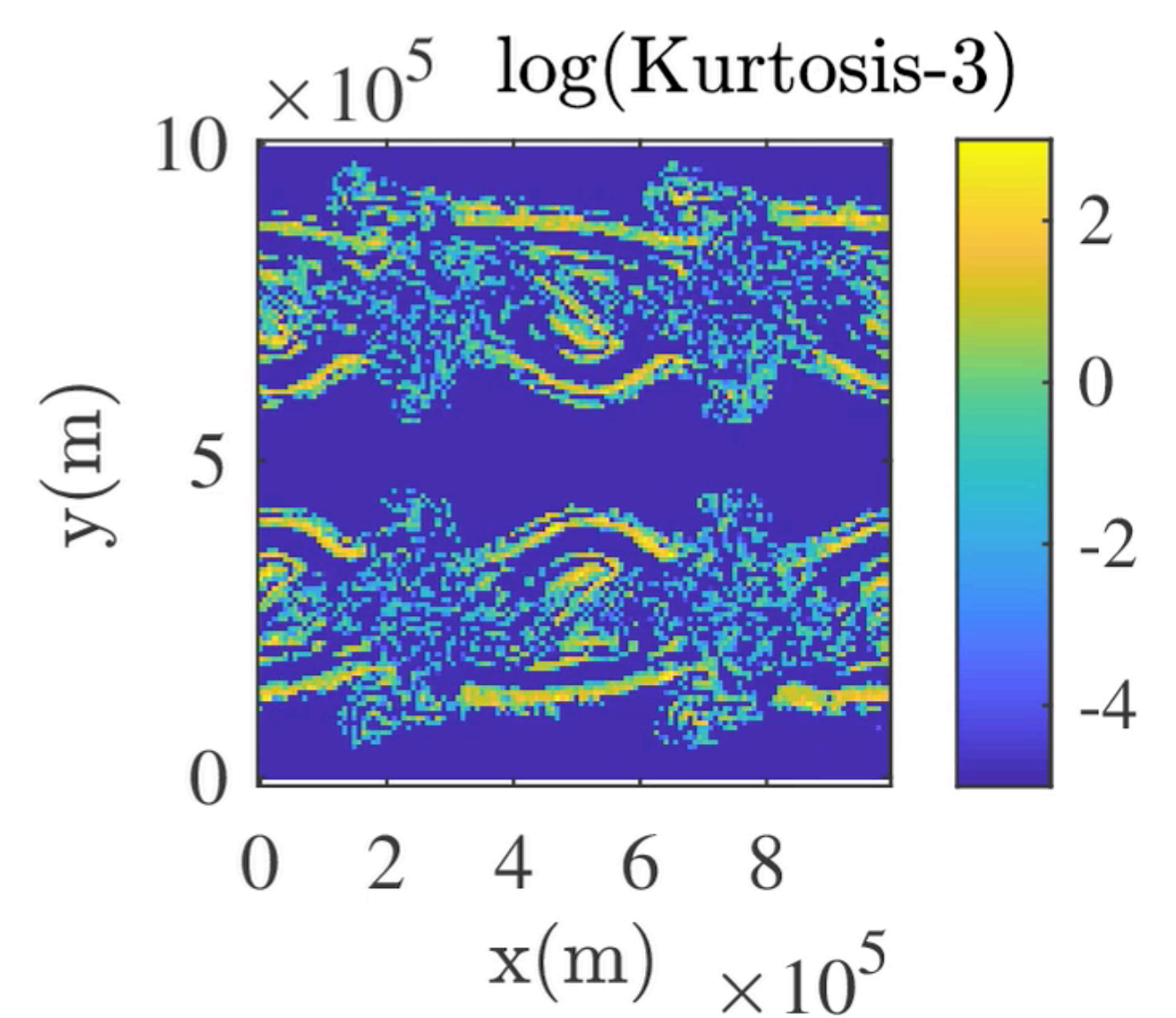
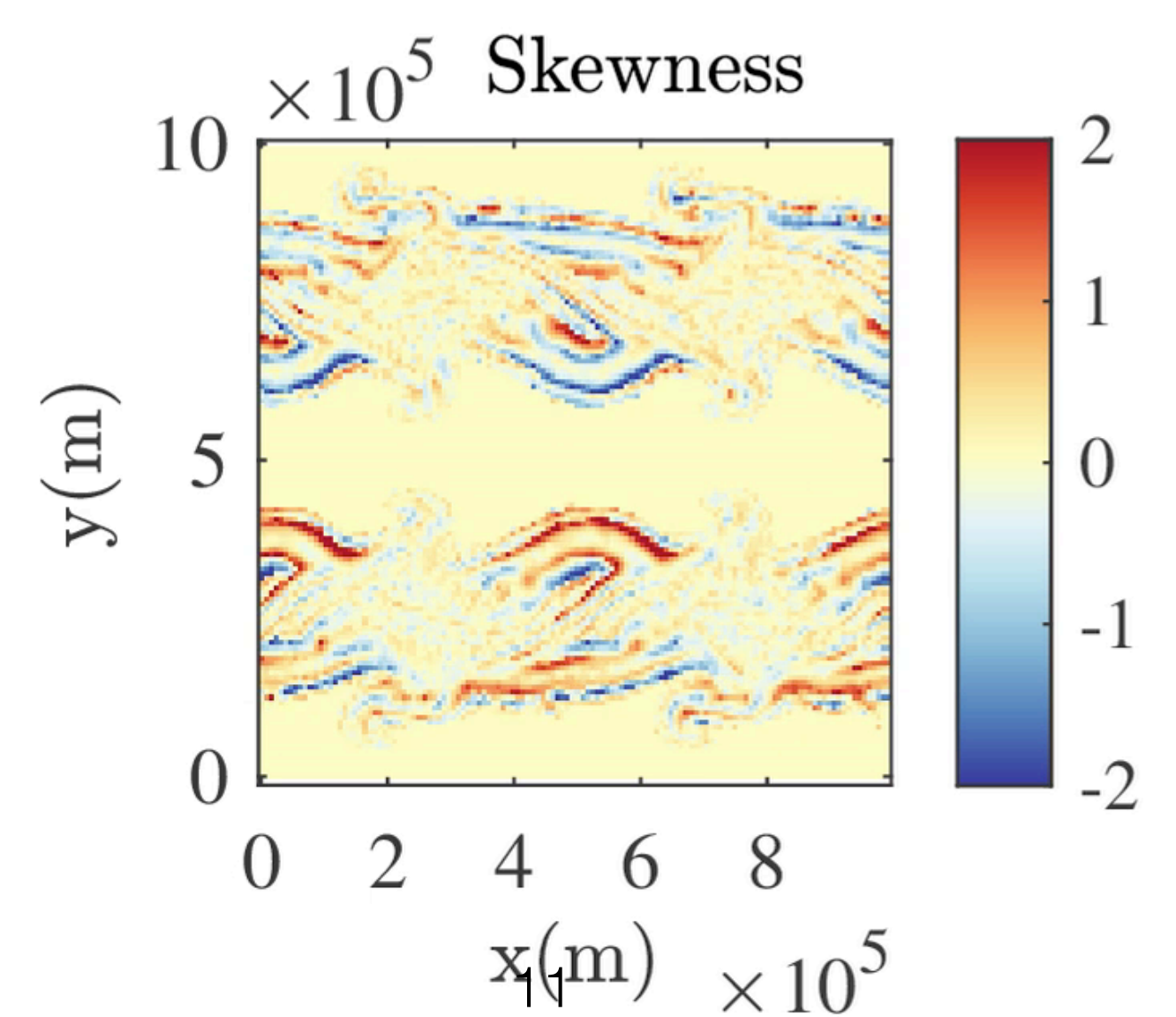
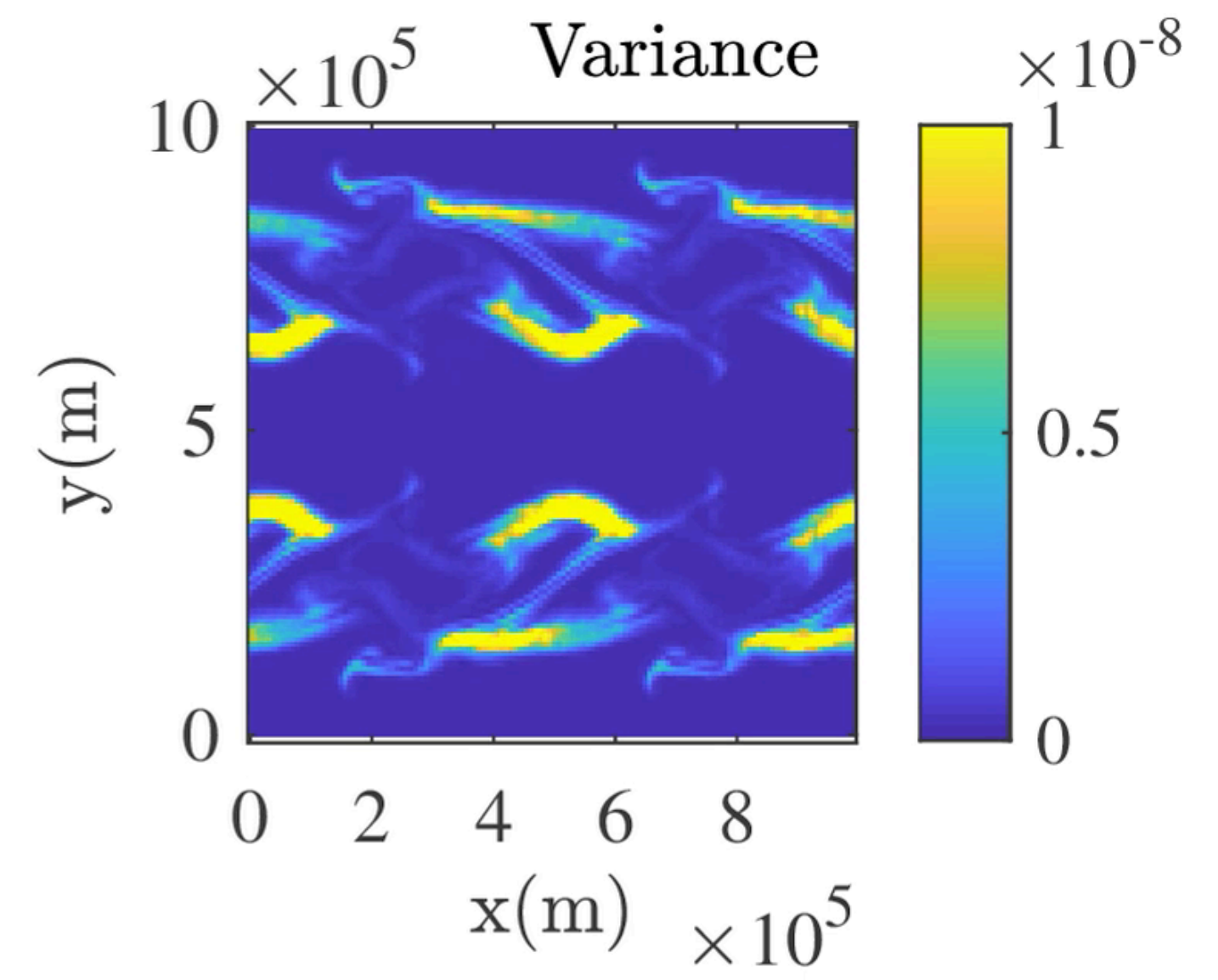
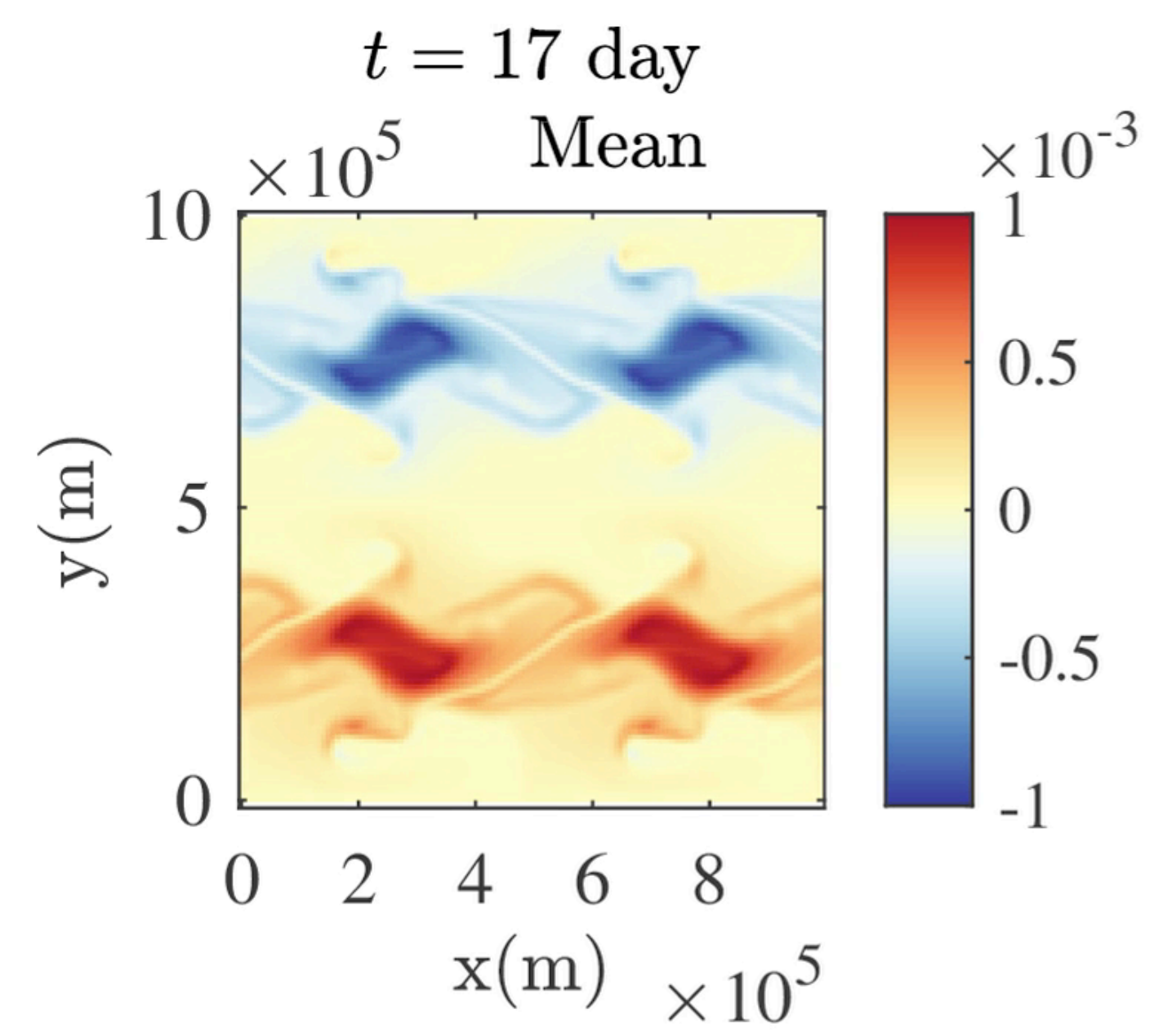

Ensemble : uncertainty quantification

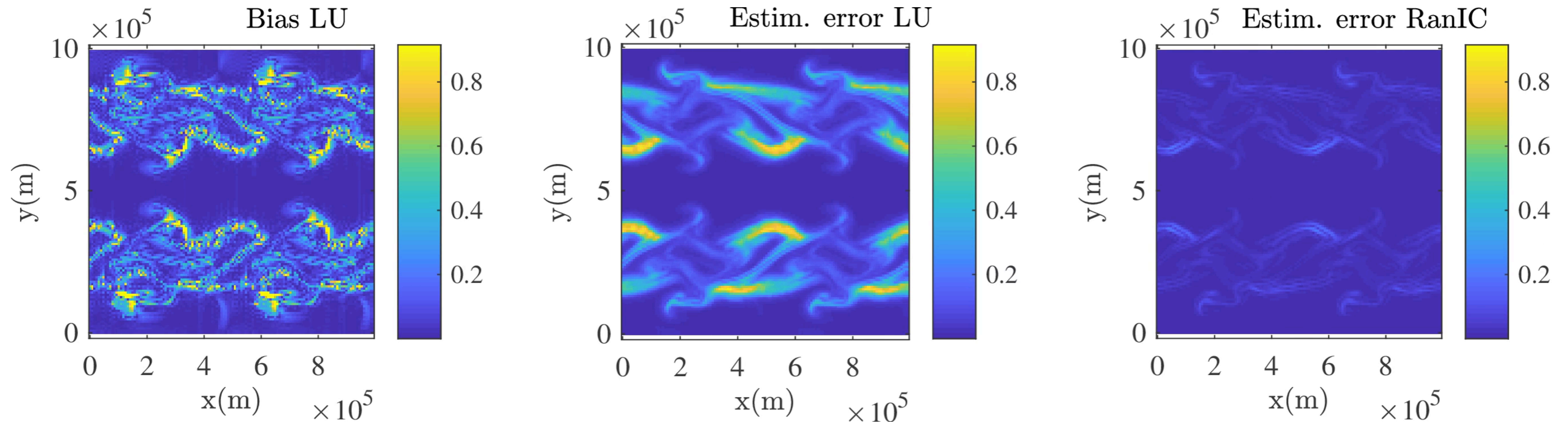

Spectrum of the errors and its estimation

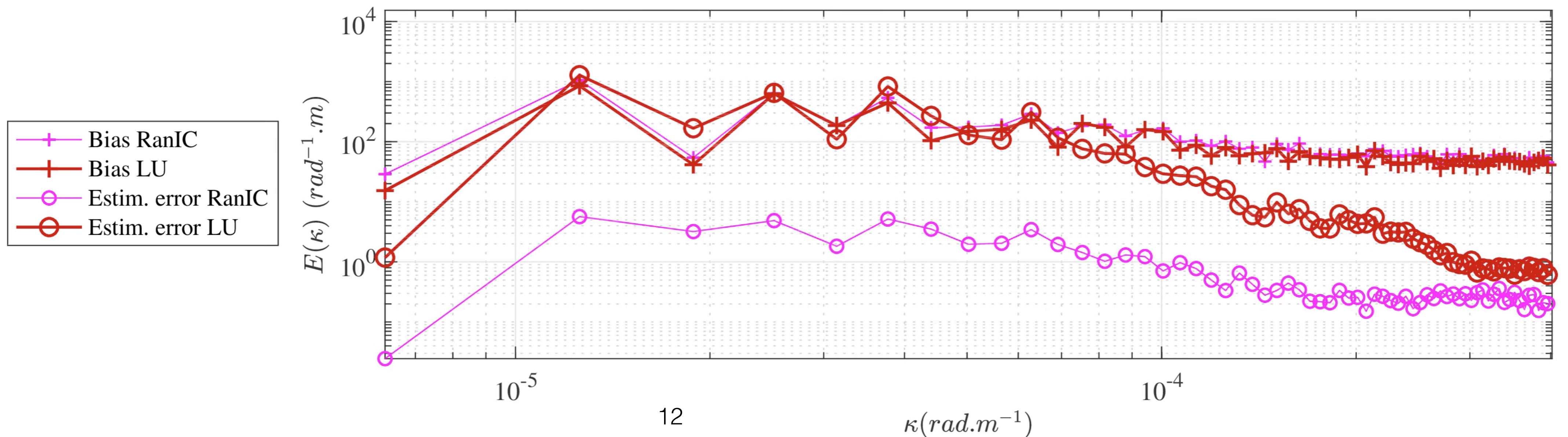

Ensemble : uncertainty quantification

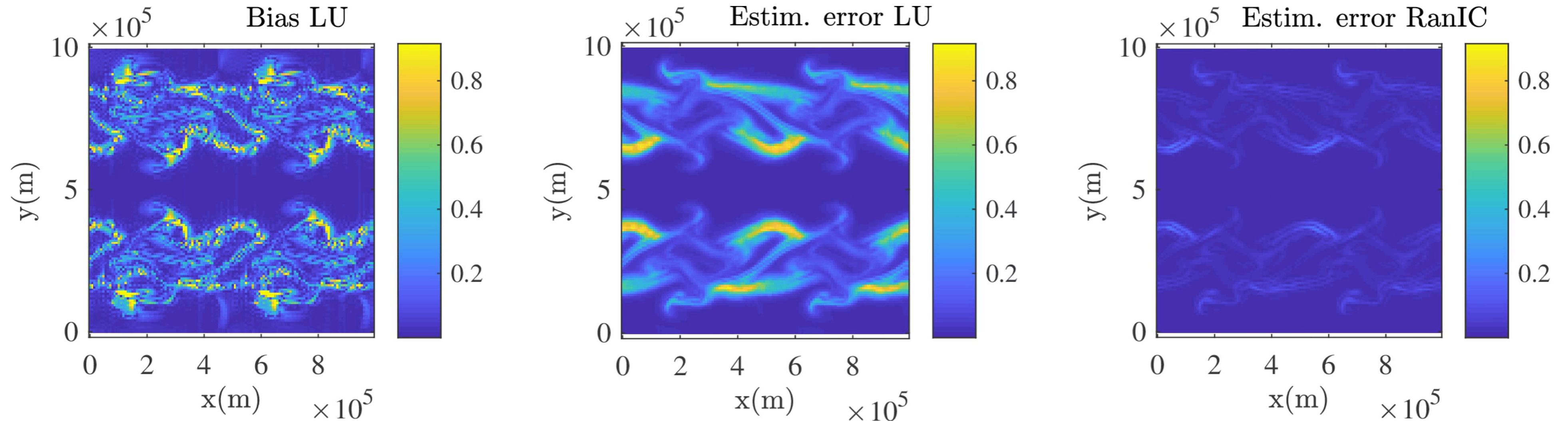
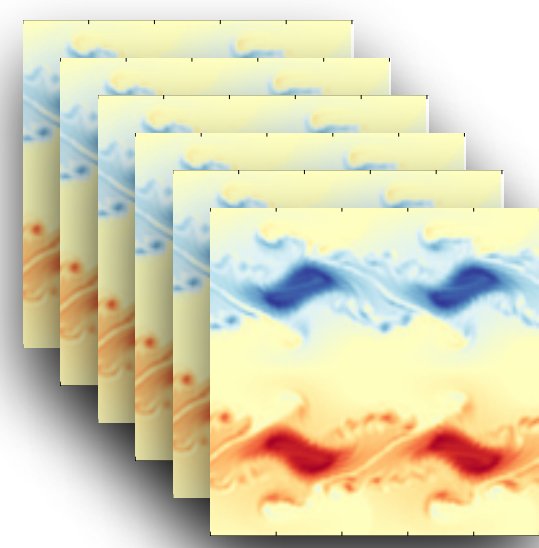

Spectrum of the errors and its estimation

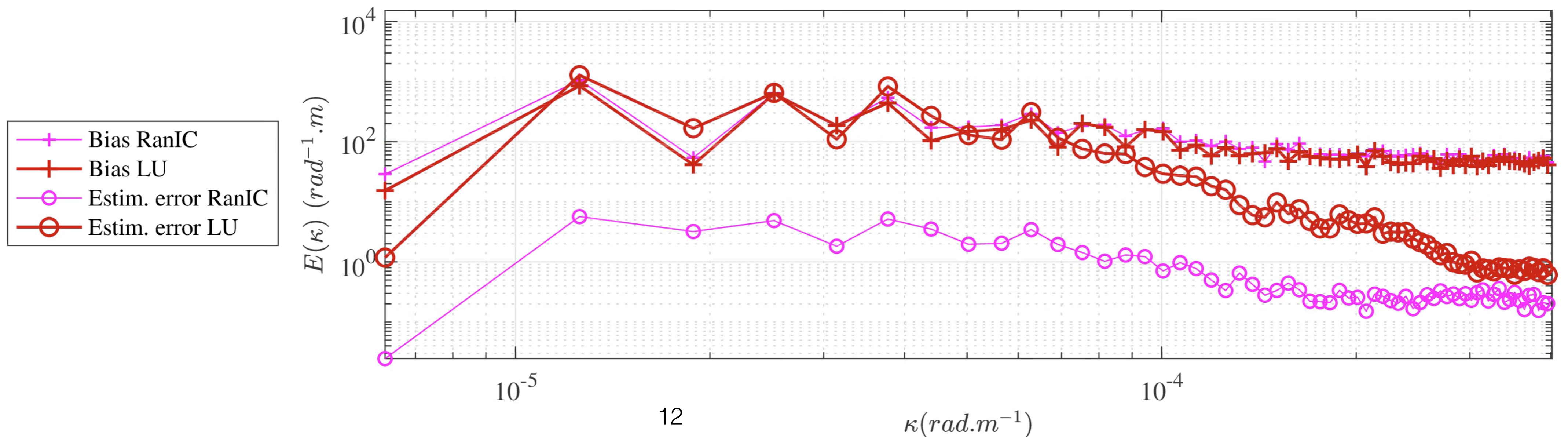

Conclusion

Models under location uncertainty blindly describe unresolved triades

- Conserve energy
- Model derivation
- Instabilities triggered,
possibly followed by extreme events
- Uncertainty quantification to address filter divergence

Related works and outlooks

- Bifurcations (SQG) and attractor (Lorenz 63) exploration
- Stabilization / destabilization of Reduced Order Model
- Comparisons with data-driven σ and Stochastic Lie Derivative approaches (Holm and coauthors)
- Parametrization and tests based on higher-order statistics (curvature, energy flux through scales, bispectrum, ...)
- Mimic barotropization
- Girsanov theorem for MLE and Bayesian estimations with satellite images
- Learning σ on SWOT data
- Filtering / smoothing with (reduced) models under location uncertainty