



HAL
open science

Screening in the finite-temperature reduced Hartree-Fock model

Antoine Levitt

► **To cite this version:**

Antoine Levitt. Screening in the finite-temperature reduced Hartree-Fock model. Archive for Rational Mechanics and Analysis, In press. hal-01889411v1

HAL Id: hal-01889411

<https://hal.science/hal-01889411v1>

Submitted on 6 Oct 2018 (v1), last revised 15 Jul 2020 (v2)

HAL is a multi-disciplinary open access archive for the deposit and dissemination of scientific research documents, whether they are published or not. The documents may come from teaching and research institutions in France or abroad, or from public or private research centers.

L'archive ouverte pluridisciplinaire **HAL**, est destinée au dépôt et à la diffusion de documents scientifiques de niveau recherche, publiés ou non, émanant des établissements d'enseignement et de recherche français ou étrangers, des laboratoires publics ou privés.

SCREENING IN THE FINITE-TEMPERATURE REDUCED HARTREE-FOCK MODEL

ANTOINE LEVITT

ABSTRACT. We prove the existence of solutions of the reduced Hartree-Fock equations at finite temperature for a periodic crystal with a small defect, and show total screening of the defect charge by the electrons. We also show the convergence of the damped self-consistent field iteration using Kerker preconditioning to remove charge sloshing. As a crucial step of the proof, we define and study the properties of the dielectric operator.

1. INTRODUCTION

A point charge Q placed in vacuum creates an electric potential $\frac{Q}{4\pi\epsilon_0 r}$, r being the distance to the charge and ϵ_0 being the permittivity of the vacuum. By contrast, when an defect is placed in a material, the material reorganises itself: a positive charge creates an energetically favorable region for the electrons, which flock towards the defect. At equilibrium, they form a “shield” of negative charge, effectively screening the Coulomb interaction at long range.

Phenomenologically, insulators and metals exhibit a different screening behavior. In insulators, electrons are tightly bound to the nuclei, and cannot deviate too much from their equilibrium position to move towards the defect. Accordingly, the long-range behavior of the total potential, including the effects of the electrons, is $Q/(4\pi\epsilon r)$, where $\epsilon > \epsilon_0$ is the permittivity of the material. Thus, effectively, the charge Q is scaled by the dielectric constant ϵ/ϵ_0 : this is called partial screening.

In metals, however, electrons are free to move in response to the defect and totally screen it, so that the total potential becomes effectively short-range. A simple model for the total potential is the Yukawa potential

$$V(x) = \frac{Qe^{-k|x|}}{|x|}$$

where $1/k$ is the screening length. At low temperatures however, V displays an oscillatory behavior with a power-law decay, called Friedel oscillations.

The purpose of this paper is to justify the total screening of small defects in the reduced Hartree-Fock (rHF) model at finite temperature. This is to be contrasted with the partial screening of insulators at zero temperature obtained in [7] in the same model: at finite temperature, electrons are mobile and behave as in a metal. We also justify the Kerker preconditioning scheme, which neutralizes the “charge sloshing” effect that slows down simple self-consistent iterations in extended systems [14].

For a finite system of N_{el} electrons in an external potential V_{ext} , the reduced Hartree-Fock (rHF) equation for the total potential V is given by

$$\begin{cases} V = V_{\text{ext}} + v_c F_{\epsilon_F}(V), \\ \int_{\mathbb{R}^3} F_{\epsilon_F}(V) = N_{\text{el}}. \end{cases}$$

The Coulomb operator v_c is given by the convolution

$$(v_c \rho)(x) = \frac{1}{4\pi} \int_{\mathbb{R}^3} \frac{\rho(y)}{|x-y|} dy.$$

The potential-to-density mapping F_{ϵ_F} is given by

$$F_{\epsilon_F}(V) = f_{\epsilon_F}(-\Delta + V)(x, x)$$

where the Fermi-Dirac distribution f_{ε_F} is

$$f_{\varepsilon_F}(\varepsilon) = \frac{1}{1 + e^{\frac{\varepsilon - \varepsilon_F}{k_B T}}},$$

with T the temperature and k_B the Boltzmann constant. The density matrix $f_{\varepsilon_F}(H)$ is defined through the functional calculus of self-adjoint operators, and $f_{\varepsilon_F}(H)(x, x)$ is the associated density (see Section 3.3). The Fermi level ε_F is determined through the charge neutrality condition $\int_{\mathbb{R}^3} F_{\varepsilon_F}(V) = N_{\text{el}}$.

This model, also called the Hartree model, random phase approximation (RPA) or Schrödinger-Poisson, can be seen as a simplification of Kohn-Sham density functional theory where the exchange-correlation potential is neglected, or of the Hartree-Fock model without the exchange term. In the zero-temperature case, it derives from a convex variational principle, which allows for a complete existence and uniqueness theory [24].

This convexity also means that it is possible to justify rigorously the thermodynamic limit for periodic systems [9], something that seems out of reach for the full Hartree-Fock or Kohn-Sham model. The resulting periodic model takes the following form. Let \mathcal{R} be the crystal lattice, Γ a unit cell, and W_{nucl} the \mathcal{R} -periodic potential created by the nuclei. Then the periodic rHF model is

$$(1) \quad \begin{cases} W = W_{\text{nucl}} + v_{\text{per}} F_{\varepsilon_F}(W) \\ \int_{\Gamma} F_{\varepsilon_F}(W) = N_{\text{el}} \end{cases}$$

where $v_{\text{per}}\rho$ is the unique periodic solution of

$$(2) \quad \begin{cases} -\Delta(v_{\text{per}}\rho) = \rho \\ \int_{\Gamma}(v_{\text{per}}\rho) = 0 \end{cases}$$

and N_{el} is now the number of electrons per unit cell. The potential-to-density mapping takes the same form $F_{\varepsilon_F}(W) = f_{\varepsilon_F}(-\Delta + W)(x, x)$, and maps periodic potentials to periodic densities.

The periodic model with zero temperature was studied in [9], where it is derived as a thermodynamic limit. The existence and uniqueness of solutions $W(W_{\text{nucl}})$ to (1) at finite temperature was proved in [19], using a variational principle for the potential W . We study the convergence of fixed-point iterations to solve these equations, both for its independent interest and to establish the methods and estimates needed later for the study of defects. First, for a given W , the charge neutrality condition can be uniquely solved for ε_F (see Lemma 4.2), yielding a map $\varepsilon_F(W)$ and allowing us to reformulate the self-consistent equation as simply $W = W_{\text{nucl}} + v_{\text{per}}F(W)$, with $F(W) = F_{\varepsilon_F(W)}$. A very natural iterative method to solve this equation is

$$W_{n+1} = W_{\text{nucl}} + v_{\text{per}}F(W_n),$$

the simple self-consistent iteration. Unfortunately, as is well-known, this algorithm does not necessarily converge, not even locally [6, 16]. This suggests the simple damping (or mixing) strategy

$$(3) \quad W_{n+1} = W_n + \alpha(W_{\text{nucl}} + v_{\text{per}}F(W_n) - W_n)$$

for small α . It is not *a priori* clear why this iteration, based on an arbitrary splitting of the self-consistent equation, should converge, even for small $\alpha > 0$. We prove that this is the case (recall that L_{per}^2 is the space of \mathcal{R} -periodic functions that are square-integrable over the unit cell Γ)

Theorem 1.1. *Assume that there is $W_{\text{nucl}}^* \in L_{\text{per}}^2$ and $W^* \in L_{\text{per}}^2$ such that $W^* = W_{\text{nucl}} + v_{\text{per}}F(W^*)$. Then there are $\alpha_0 > 0$, neighborhoods $\mathcal{W}_{\text{nucl}}$ of W_{nucl}^* and \mathcal{W} of W^* in L_{per}^2 such that, for all $W_{\text{nucl}} \in \mathcal{W}_{\text{nucl}}$, there is a unique solution $W(W_{\text{nucl}}) \in \mathcal{W}$ of $W = W_{\text{nucl}} + v_{\text{per}}F(W)$. Furthermore, for all $0 < \alpha \leq \alpha_0$, the iteration (3) with $W_0 \in \mathcal{W}$ converges to $W(W_{\text{nucl}})$ in L_{per}^2 .*

Note that the Jacobian of the fixed-point mapping (3) is

$$J_\alpha(W) = 1 - \alpha + \alpha v_{\text{per}} F'_{\varepsilon_F}(W).$$

We show in Lemma 4.1 that the Jacobian $F'_{\varepsilon_F}(W)$ is self-adjoint and non-positive from L^2_{per} to itself. Since $v_{\text{per}} F'_{\varepsilon_F}(W)$ is the product of a non-negative and a non-positive self-adjoint operator, it has non-positive spectrum, and therefore J_α will have spectrum between -1 and 1 for α small enough, proving Theorem 1.1. To analyze $F'_{\varepsilon_F}(W)$, we use a contour integral formulation which allows us to prove sum-over-states expressions for the derivatives. A similar method was used in [19]. Although we focus on this very simple algorithm, the behavior of more complex algorithms such as Anderson acceleration (also known as DIIS or Pulay mixing) depends crucially on the properties of the underlying fixed-point iteration [25], and our analysis is a necessary first step towards the understanding of these methods.

We next study defects. The model for defects at zero temperature for insulators at zero temperature was introduced in [3], again through a thermodynamic limit argument. At finite temperature, the model is as follows. We fix a solution W_{per} of the periodic model above and its Fermi level ε_F . For a given defect potential V_{def} , we solve the equation

$$(4) \quad V = V_{\text{def}} + v_c G(V)$$

for the total potential V , with $G(V)$ the renormalized potential-to-density mapping

$$(5) \quad G(V) = (f_{\varepsilon_F}(-\Delta + W_{\text{per}} + V) - f_{\varepsilon_F}(-\Delta + W_{\text{per}}))(x, x).$$

We note that, to our knowledge, neither this defect model nor even the periodic model has been derived from a thermodynamic limit for the rHF model at finite temperature (see [10] for related work in a simpler model).

It is natural to try to solve these equations by a procedure similar to (3):

$$(6) \quad V_{n+1} = V_n + \alpha(V_{\text{def}} + v_c G(V_n) - V_n).$$

However, in contrast to the periodic case, the operator v_c is not bounded. This is easily seen by noting that v_c acts in Fourier space as a multiplication operator by $1/|q|^2$. The iteration (6) is therefore not well-defined. The practical consequence of this is that, when the equations are truncated to a finite box of linear size L with appropriate boundary conditions, v_c has eigenvalues on the order of L^2 . This forces α to be on the order of L^{-2} , which slows down the convergence¹. Because the large eigenvalues are caused by low wavelengths, this appears in calculations as charge moving back and forth at the extremities of the system, a phenomenon known as charge sloshing [14]. This effect does not appear when the density is constrained to be periodic, as evidenced by Theorem 1.1.

This can be fixed by using a more elaborate numerical method. The Newton method applied to (4) is

$$V_{n+1} = V_n + J(V_n)^{-1}(V_{\text{def}} + v_c G(V_n) - V_n)$$

where

$$J(V) = 1 - v_c G'(V)$$

There is an intimate link between the Jacobian $J(V)$, describing the behavior of iterative algorithms, and the linear response properties of the system. The operator $\chi_0 = G'(0)$ is called the independent-particle susceptibility operator. It describes the linear response of the density of a non-interacting system of electrons to a small defect potential. It can be computed through the Adler-Wiser sum-over-states formula [1, 26], which we prove in Lemma 5.2. The operator $\varepsilon^{-1} = J(0)^{-1} = (1 - v_c \chi_0)^{-1}$ is called the dielectric operator. As we will see, it describes the linear response of the total potential V to a defect V_{def} .

¹This reasoning also holds true for more complex methods. The Jacobian of the system has a condition number proportional to L^2 , and therefore we expect simple methods to require a number of iterations proportional to L^2 , and Krylov-type methods such as Anderson acceleration to require a number of iterations proportional to L [25, 22].

Since $J(V)$ or even $J(0)$ is difficult to compute, an approximation has to be found, yielding a preconditioned scheme. A simple approximation can be found using the Thomas-Fermi theory of the free electron gas [17]. This model takes the same form (4) of a fixed-point equation, but with a much simpler potential-to-density mapping

$$G_{\text{TF}}(V) = (\varepsilon_F - V)_+^{\frac{3}{2}}.$$

In this case we simply have $\chi_{0,\text{TF}} = G'_{\text{TF}}(0) = -\frac{3}{2}\sqrt{\varepsilon_F}$. Because of translational invariance, the operator $\varepsilon_{\text{TF}} = J_{\text{TF}}(0)$ takes the simple form of a multiplication operator in Fourier space

$$\varepsilon_{\text{TF}}(q) = 1 - \frac{1}{|q|^2}\chi_{0,\text{TF}} = \frac{|q|^2 - \chi_{0,\text{TF}}}{|q|^2}.$$

The $1/|q|^2$ divergence for low wavelengths created by Coulomb interaction is the cause of charge sloshing. One can then simply take the inverse of this Thomas-Fermi Jacobian as a preconditioner. In practice, the unknown constant $\chi_{0,\text{TF}}$ is estimated according to the system under consideration (in this paper we take it equal to -1 for simplicity). This choice,

$$(7) \quad \mathcal{K}(q) = \frac{|q|^2}{1 + |q|^2},$$

or in operator form $\mathcal{K} = \frac{-\Delta}{1-\Delta}$, is known as Kerker preconditioning [14]. The preconditioned fixed-point iteration is then

$$(8) \quad V_{n+1} = V_n + \alpha\mathcal{K}(V_{\text{def}} + v_c G(V_n) - V_n)$$

which is found in practice to substantially improve the convergence of self-consistent algorithms.

We now turn to the related matter of screening. Expanding (4) to first order in V_{def} , we obtain formally

$$V = (1 - v_c\chi_0)^{-1}V_{\text{def}} + O(\|V_{\text{def}}\|^2).$$

As mentioned previously, the operator

$$(9) \quad \varepsilon^{-1} = (1 - v_c\chi_0)^{-1}$$

is the dielectric operator. In the case of the homogeneous Thomas-Fermi model, χ_0 is a negative constant, and $\varepsilon_{\text{TF}}^{-1}$ is a Fourier multiplication operator given by

$$\varepsilon_{\text{TF}}^{-1}(q) = \frac{|q|^2}{|q|^2 - \chi_{0,\text{TF}}}$$

When $V_{\text{def}}(x) = \frac{Q}{|x|}$, up to normalization we have $\widehat{V_{\text{def}}}(q) = \frac{Q}{|q|^2}$, and so

$$\widehat{\varepsilon_{\text{TF}}^{-1}V_{\text{def}}}(q) = \frac{Q}{|q|^2 - \chi_{0,\text{TF}}},$$

the Fourier transform of a short-range Yukawa potential

$$(\varepsilon_{\text{TF}}^{-1}V_{\text{def}})(x) = Q \frac{e^{-\sqrt{-\chi_{0,\text{TF}}}|x|}}{|x|}.$$

The Thomas-Fermi theory of screening beyond linear response was discussed in [17], and extended to the Thomas-Fermi-von Weiszäcker model in [4, 18].

The purpose of this paper is to extend the justification of Kerker preconditioning as well as the Thomas-Fermi theory of screening to the more realistic rHF model of defects.

Our main result is

Theorem 1.2. *Fix $W_{\text{per}} \in L^2_{\text{per}}$ and $\varepsilon_F \in \mathbb{R}$. There are $\alpha_0 > 0$ and neighborhoods \mathcal{V}_{def} and \mathcal{V} of 0 in $v_c H^{-2}$ and L^2 respectively such that, for all $V_{\text{def}} \in \mathcal{V}$, there is a unique solution $V(V_{\text{def}})$ of*

$$V = V_{\text{def}} + v_c G(V)$$

in \mathcal{V} . Furthermore, for $0 < \alpha \leq \alpha_0$, the iteration

$$V_{n+1} = V_n + \alpha \mathcal{K}(V_{\text{def}} + v_c G(V_n) - V_n).$$

with $V_0 \in \mathcal{V}$ converges to $V(V_{\text{def}})$ in L^2 .

We have the expansion

$$V(V_{\text{def}}) = \varepsilon^{-1} V_{\text{def}} + O(\|V_{\text{def}}\|_{v_c H^{-2}}^2)$$

in L^2 , where

$$\varepsilon^{-1} = (1 - v_c \chi_0)^{-1}$$

is continuous from $v_c H^{-2}$ to L^2 , and $\chi_0 = G'(0)$ is continuous from L^2 to itself.

When for instance $V_{\text{def}}(x) = \frac{Q}{|x|}$ for Q small enough (which belongs to $v_c H^{-2}$), this result states that the screened potential $V(V_{\text{def}})$ is in L^2 , and therefore decays faster than V_{def} . When the defect potential is the Coulomb potential generated by a localized charge density ρ , we expect from the analysis of the Thomas-Fermi model that $V(V_{\text{def}})$ will have the same decay properties as ρ (because $q \mapsto \frac{\varepsilon_{\text{TF}}^{-1}(q)}{|q|^2}$ is smooth). To quantify this, we need to define the weighted Sobolev spaces (see Section 2 for more details): for every $n \in \mathbb{R}, N \geq 0$,

$$L_N^2 = \left\{ f \in L^2, \int_{\mathbb{R}^3} (1 + |x|^2)^N |f(x)|^2 dx < \infty \right\}$$

and

$$H_N^n = \{f, (1 + |x|^2)^{\frac{N}{2}} f \in H^n\}.$$

We then have

Theorem 1.3. *Fix $W_{\text{per}} \in L_{\text{per}}^2$ and $\varepsilon_F \in \mathbb{R}$. There is a neighborhood $\widetilde{\mathcal{V}}_{\text{def}} \subset \mathcal{V}_{\text{def}}$ of zero in $v_c H_1^{-2}$ such that, if $V_{\text{def}} \in \widetilde{\mathcal{V}}_{\text{def}}$, and if $V_{\text{def}} \in v_c H_N^{-2}$, then $V(V_{\text{def}}) \in L_N^2$.*

Therefore, if $V_{\text{def}}(x) = \frac{Q}{|x|}$ for Q small enough, then $V(V_{\text{def}})$ decays faster than any polynomial.

To prove Theorem 1.2, we need to generalize the results of the Thomas-Fermi model to our setting. The first obstacle is the more complicated nature of the potential-to-density mapping G . This is handled by using a contour-integral formulation, which allows for the computation of response functions (derivatives of G). The second is the absence of translation invariance, and therefore of the simple decomposition of operators Fourier space. However, the periodicity of the underlying crystal allows the use of the Bloch transform, which replaces the Fourier transform used in the homogeneous case. We also need to establish the invertibility of the operator $\varepsilon \mathcal{K}$, which is done by studying the low-wavelength behavior of the independent-particle susceptibility operator χ_0 , and relating it to $F'_{\varepsilon_F}(W_{\text{per}})$. Finally, the improved decay estimates in Theorem 1.3 are obtained by considering the off-diagonal decay of the resolvent of the periodic Hamiltonian, a property related to the well-known locality of the density matrix [20, 2, 5].

Remark 1.4 (Exponential decay). *It follows from our estimates that the operator $\varepsilon^{-1} v_c$ representing the linear response of the screened potential to a defect charge density has an exponentially decaying kernel. Indeed, from the proof of Lemma 5.2 one can see that its fibers are analytic in a strip in the complex plane, and therefore $\varepsilon^{-1} v_c$ maps exponentially decaying charge densities to exponentially decaying potentials. The exponential decay rate depends in particular on the temperature. Proving this for the non-linear mapping $V(V_{\text{def}})$ requires the use of more involved functional spaces quantifying exponential decay, and we do not do it in this paper.*

Remark 1.5 (Zero temperature limit). *The results above are to be compared with those of [7] (see also [8] for the dynamical case). There, the authors study the linear response in the case of insulators at zero temperature. They obtain partial screening, whereby the total potential behaves at long range as a Coulombic potential whose effective charge is reduced by a constant factor*

(the dielectric constant of the material). The difference can be schematized as follows: in the case of insulators at zero temperature, the independent-particle susceptibility operator χ_0 behaves for low wavelengths as $|q|^2$, reflecting the lack of bulk movement of electrons. Accordingly, the dielectric operator $\varepsilon^{-1} = (1 - v_c \chi_0)^{-1}$ behaves as a constant. In the finite-temperature case, χ_0 behaves as a constant for low wavelengths, and therefore ε^{-1} behaves as $|q|^2$.

The discussion above in terms of wavelengths is complicated by the fact that these operators do not commute with all translations but only with those of the crystal lattice, and so are not diagonalized by the Fourier transform but by the Bloch transform. Because of the appearance of the inverse, the behavior of ε^{-1} for low wavelengths is not determined only by that of χ_0 for low wavelengths. This discrepancy is sometimes called “local field effects” in the physical literature. However, the conclusions above are qualitatively correct, although the proper treatment of these effects is more involved, as we will see.

This work is only concerned with the finite-temperature case. Physically, this has the effect of making every material metallic, in the sense that there are free electrons available to move towards the defect. Mathematically, this allows response functions to be derived straightforwardly from contour integrals. The case of the zero-temperature limit of metals remains open (although see [11] in the linear case). A particular challenge is that of the appearance of Friedel oscillations, which in the case of the free Fermi gas ($W_{\text{per}} = 0$) are linked with non-smoothness of the independent-particle susceptibility $\chi_0(q)$. In the periodic case, the shape of Friedel oscillations depends on the properties of the Fermi surface.

Remark 1.6 (Energy methods). *In this work, we are concerned with the convergence of fixed-point iterations, and screening in the small defect regime. Therefore, we use a fixed-point approach to the existence of solutions of the defect equations, and do not exploit the existence of an energy. This limits our range of applicability to small defects, and cannot ensure the uniqueness of solutions. It would be interesting to prove the existence of solutions outside of the perturbative regime through energy methods.*

The use of an energy sheds some light on the convergence of the damped fixed-point iteration, which decreases the (free) energy of the system for small enough damping parameter. Similarly, the non-positivity of the derivative of the potential-to-density mapping, which we obtained by direct computation, can also be seen through energy methods. For concreteness, we sketch this argument now in a periodic system at fixed Fermi level. Consider a periodic system of non-interacting electrons in a periodic potential W . Define the free energy (per unit cell) of a density matrix γ

$$E(\gamma, W) = \text{Tr}((-\Delta + W - \varepsilon_F)\gamma) + k_B T \text{Tr}(\gamma \log \gamma + (1 - \gamma) \log(1 - \gamma))$$

where Tr is the trace per unit cell (see Section 2). Then E is convex on a suitable subset of the convex set of periodic self-adjoint operators satisfying $0 \leq \gamma \leq 1$ and admits a unique minimizer $\gamma^*(W) = f_{\varepsilon_F}(-\Delta + W)$. The functional

$$I(W) = \inf_{\gamma} E(\gamma, W) = E(\gamma^*(W), W)$$

is concave, being the infimum of affine functionals. Its gradient is computed using an Hellmann-Feynman-type argument as

$$I'(W) = \frac{\partial E}{\partial W}(\gamma^*(W), W) = \gamma^*(W)(x, x) = F_{\varepsilon_F}(W)$$

and it follows that F'_{ε_F} , being the Hessian of a concave functional, is self-adjoint and non-positive.

Remark 1.7 (Kohn-Sham density functional theory). *We consider here the rHF model, which neglects any exchange-correlation effects. In the case of the Kohn-Sham model, the dielectric operator is*

$$\varepsilon^{-1} = (1 - (v_c + K_{\text{xc}})\chi_0)^{-1},$$

where K_{xc} is the derivative of the exchange-correlation potential with respect to the density. It is not a priori clear that the operator ε is invertible in this case, even for a finite system. This is related to the non-convexity of the model. The full investigation of this property, which can only hold locally close to a ground state, would be interesting future work.

The structure of the paper is as follows. We first introduce our notations in Section 2 and recall properties of the Bloch transform and of periodic operators. In Section 3 we state general theorems and prove some estimates on resolvents and densities of operators. Then we study the periodic rHF model in Section 4, establishing properties of the response operators and proving Theorem 1.1. We finally study the defect model in Section 5, culminating in the proof of Theorems 1.2 and 1.3.

2. NOTATIONS

Let \mathcal{R} be a periodic lattice in \mathbb{R}^3 , $\mathcal{R}^* = \{K \in \mathbb{R}^3 \mid \forall R \in \mathcal{R}, e^{iK \cdot R} = 1\}$ be its dual lattice, Γ be a unit cell of \mathcal{R} , and $\Gamma^* = \mathcal{B}$ be a unit cell of \mathcal{R}^* . By abuse of language we call \mathcal{B} the Brillouin zone. Both Γ and \mathcal{B} are considered to have the topology of a torus: this means that, for instance, a continuous function on Γ extends to a continuous and \mathcal{R} -periodic function on \mathbb{R}^3 .

We let $k_B T > 0$ be a fixed temperature, and set

$$f_{\varepsilon_F}(\varepsilon) = \frac{1}{1 + e^{\frac{\varepsilon - \varepsilon_F}{k_B T}}}$$

the Fermi-Dirac occupation function. We recall that f is decreasing on \mathbb{R} and analytic on $\mathbb{R} + i(\pi T, \pi T)$.

L^2 is the usual Lebesgue space on \mathbb{R}^3 , and $L^2_{\text{per}} \sim L^2(\Gamma)$ is the space of \mathcal{R} -periodic functions. For $s \in \mathbb{R}$, H^s is the Sobolev space on \mathbb{R}^3 and $H^s_{\text{per}} \sim H^s(\Gamma)$ the Sobolev space on the torus Γ , defined via Fourier transform and Fourier series respectively. All these spaces are Hilbert spaces with their usual inner product.

We normalize the Fourier series, transforms and Bloch transforms to consistently have unnormalized decompositions: for a function $u \in L^2_{\text{per}}$, we have

$$u(x) = \sum_{K \in \mathcal{R}^*} e^{iKx} c_K(u), \quad c_K(u) = \int_{\Gamma} e^{-iKx} u(x) dx$$

where $\int_{\Omega} = \frac{1}{|\Omega|} \int_{\Omega}$ is the normalized integral. For a function $w \in L^2$ we have

$$w(x) = \int_{\mathbb{R}^3} e^{iqx} \widehat{w}(q) dq, \quad \widehat{w}(q) = \frac{1}{(2\pi)^3} \int_{\mathbb{R}^3} e^{-iqx} w(x) dx$$

The Bloch transform for $w \in L^2$ is

$$w(x) = \int_{\mathcal{B}} e^{ikx} u_k(x) dk, \quad u_k(x) = \sum_{K \in \mathcal{R}^*} e^{iKx} \widehat{w}(k + K).$$

The map $k \mapsto u_k$ belongs to the space $L^2(\mathcal{B}, L^2_{\text{per}})$, by which we mean the space of functions $u_k : \mathbb{R}^3 \mapsto L^2_{\text{per}}$ that are locally L^2 and satisfy the pseudo-periodicity condition $u_{k+K}(x) = e^{-iKx} u_k(x)$ for all $K \in \mathcal{R}^*$. This space is equipped with the norm

$$\|u\|_{L^2(\mathcal{B}, L^2_{\text{per}})}^2 = \int_{\mathcal{B}} \|u_k\|_{L^2_{\text{per}}}^2.$$

The Bloch transform is, up to normalization, unitary from L^2 to $L^2(\mathcal{B}, L^2_{\text{per}})$.

Recall that $-i\partial_{x_i} w$ has Bloch transform $k \mapsto (-i\partial_{x_i} + k_i)u_k$, and that $x_i w$ has Bloch transform $k \mapsto i\partial_{k_i} u_k$. Let $\langle x \rangle = \sqrt{1 + |x|^2}$. For every $n, N \in \mathbb{R}$, let the weighted Sobolev spaces

$$H_N^n = \{f \in \mathcal{S}', \langle x \rangle^N f \in H^n\}$$

and

$$L_N^2 = H_N^0 = \{f \in L^2, \|\langle x \rangle^N f\|_{L^2} < \infty\}$$

with natural norms. The Fourier transform is bounded and invertible from H_N^n to H_n^N . The Bloch transform is similarly bounded and invertible from H_N^n to $H^N(\mathcal{B}, H_{\text{per}}^n)$, where $H^N(\mathcal{B}, H_{\text{per}}^n)$ is defined as above (see for instance [15]).

If A is a bounded operator on a Banach space, we call $\|A\|$ its norm, $\sigma(A)$ its spectrum and $r(A) = \lim_{n \rightarrow \infty} \|A^n\|^{1/n} = \sup\{|z|, z \in \sigma(A)\}$ its spectral radius.

We denote by \mathfrak{S}_p the space of Schatten-class operators on L^2 . The spaces \mathfrak{S}_p equipped with their norm $\|A\|_{\mathfrak{S}_p} = (\text{Tr}|A|^p)^{1/p}$ are Banach spaces (Hilbert space for $p = 2$). In particular, the cases $p = 1, 2, \infty$ correspond to trace-class, Hilbert-Schmidt and bounded operators respectively.

We say that a bounded operator A on $L^2(\mathbb{R}^3)$ is a periodic operator if it commutes with the translations of the lattice \mathcal{R} . As is well-known [21], such operators are decomposed by the Bloch transform, in the sense that there exists a family $\{A_k\}_{k \in \mathcal{B}}$ of bounded operators on L_{per}^2 such that, if $w = \int_{\mathcal{B}} e^{ikx} u_k(x) dk \in L^2$, then

$$(Aw)(x) = \int_{\mathcal{B}} e^{ikx} (A_k u_k)(x) dk.$$

We call the operators A_k the fibers of A . The smoothness of the fibers of operators reflect the off-diagonal properties of their kernel: if an operator A has fibers A_k that are smooth from \mathbb{R}^3 to bounded operators from H_{per}^n to H_{per}^m and if $w \in H_N^n$ for some $N \geq 0$, then $Aw \in H_N^m$.

If A_k are trace-class on L_{per}^2 almost everywhere and $\int_{\mathcal{B}} \text{Tr}|A_k| < \infty$, we define the trace per unit cell

$$\underline{\text{Tr}}A = \int_{\mathcal{B}} \text{Tr} A_k.$$

One can then define the Schatten classes of periodic operators

$$\mathfrak{S}_{p,\text{per}} = \{A \text{ periodic, } \underline{\text{Tr}}|A|^p < \infty\}$$

with associated norms. Note that this is distinct from (and larger than) the class of Schatten operators on L_{per}^2 .

If $A \in \mathfrak{S}_1$, then A has the singular value decomposition $A = \sum_{n \in \mathbb{N}} \lambda_n |\phi_n\rangle\langle\psi_n|$ with ϕ_n and ψ_n two orthonormal sets and $\sum_{n \in \mathbb{N}} |\lambda_n| < \infty$, and we define its density $A(x, x) \in L^1$ by

$$A(x, x) = \sum_{n \in \mathbb{N}} \lambda_n \phi_n(x) \overline{\psi_n(x)}.$$

Similarly, if A is locally trace class then $A(x, x) \in L_{\text{loc}}^1$, if A is a trace-class operator on L_{per}^2 then $A(x, x) \in L_{\text{per}}^1$ and if A is in $\mathfrak{S}_{1,\text{per}}$ then $A(x, x) \in L_{\text{per}}^1$, with

$$A(x, x) = \int_{\mathcal{B}} A_k(x, x) dk.$$

3. GENERAL RESULTS AND ESTIMATES

3.1. General results. We recall the following classical properties

Lemma 3.1. *Let X be a Banach space and A, B be bounded operators on X . Then $\sigma(AB) \setminus \{0\} = \sigma(BA) \setminus \{0\}$.*

Proof. Let $\lambda \notin \sigma(AB)$ and $\lambda \neq 0$. Then $(\lambda - BA)$ is invertible with inverse

$$(\lambda - BA)^{-1} = \lambda^{-1}(1 + B(\lambda - AB)^{-1}A)$$

and $\lambda \notin \sigma(BA)$. The proof follows by interchanging A and B . \square

Lemma 3.2. *Let X be a Banach space and A a bounded operator on X . Then for every $\varepsilon > 0$, there is a norm $\|\cdot\|_{\varepsilon}$ equivalent to $\|\cdot\|_X$ such that $\|A\|_{\varepsilon} \leq r(A) + \varepsilon$.*

Proof. See [13] for instance. □

We will make use of the following variant of the Banach fixed point theorem:

Theorem 3.3. *Let X, Y be two Banach spaces, U and V be two neighborhoods of $x^* \in X$ and $y^* \in Y$, and $T : U \times V \mapsto X$ be a continuously differentiable mapping such that $T(x^*, y^*) = x^*$, and*

$$r \left(\frac{\partial T}{\partial x}(x^*, y^*) \right) < 1.$$

Then there are neighborhoods $\tilde{U} \subset U$ and $\tilde{V} \subset V$ of x^ and y^* such that, for all $y \in \tilde{V}$, the iteration*

$$(10) \quad x_{n+1} = T(x_n, y)$$

with $x_0 \in U$ converges to a solution $x(y)$ of $T(x(y), y) = x(y)$ in \tilde{U} . This solution is unique in \tilde{U} . Furthermore, $x(y)$ is differentiable, and

$$x'(y) = \left(1 - \frac{\partial T}{\partial x}(x(y), y) \right)^{-1} \frac{\partial T}{\partial y}(x(y), y).$$

Proof. Applying Lemma 3.2 to $A = \frac{\partial T}{\partial x}(x^*, y^*)$ and using the continuous differentiability of T , we see that, for all $\varepsilon > 0$, there is an equivalent norm $\|\cdot\|_\varepsilon$ on X such that

$$\left\| \frac{\partial T}{\partial x}(x, y) \right\|_\varepsilon \leq r \left(\frac{\partial T}{\partial x}(x^*, y^*) \right) + \varepsilon + O(\|x - x^*\| + \|y - y^*\|)$$

It follows that, for ε small enough, there is a neighborhood $\tilde{U} \times \tilde{V}$ of (x^*, y^*) such that, for every $y \in \tilde{V}$, $T(\cdot, y)$ maps \tilde{U} to itself and is a contraction for the $\|\cdot\|_\varepsilon$ norm. The convergence of (10) (in the $\|\cdot\|_\varepsilon$ and therefore in the $\|\cdot\|$ norm), as well as the uniqueness of $x(y)$ follows from the Banach fixed-point theorem. The differentiability follows as in the proof of the implicit function theorem. □

Remark 3.4. *The implicit function theorem also shows the existence of $x(y)$ under weaker assumptions (that $1 - \frac{\partial T}{\partial x}$ is invertible). The main difference is that the implicit function theorem uses the Newton-like iteration $x_{n+1} = x_n + (1 - \frac{\partial T}{\partial x}(x^*, y^*))^{-1}(T(x_n, y) - x_n)$ instead of the simpler iteration (10). We use here this version because we are interested in the convergence of the fixed-point iteration.*

Recall that in general $r(\frac{\partial T}{\partial x}) < \|\frac{\partial T}{\partial x}\|$ for general non-normal operators, and therefore T is not necessarily a contraction.

3.2. Resolvent estimates. In the following, we want to prove that products of resolvents and potentials have certain trace properties, in order to define potentials-to-density mappings via contour integrals. The following equality, a building block of the general Kato-Seiler-Simon inequality [23], will be very useful:

Lemma 3.5 (Kato-Seiler-Simon equality). *For every $f \in L^2$, $g \in L^2$, $f(-i\nabla)g(x) \in \mathfrak{S}_2$ and*

$$\|f(-i\nabla)g(x)\|_{\mathfrak{S}_2} = (2\pi)^{-3/2} \|f\|_{L^2} \|g\|_{L^2}.$$

Similarly, for $f \in L^2$, $g \in L^2_{\text{per}}$,

$$\|f(-i\nabla)g(x)\|_{\mathfrak{S}_{2,\text{per}}} = (2\pi)^{-3/2} \|f\|_{L^2} \|g\|_{L^2_{\text{per}}}.$$

Proof. The proof of the first assertion is standard, see e.g. [23]: note that $f(-i\nabla)g(x)$ has integral kernel

$$(f(-i\nabla)g(x))(x, y) = \check{f}(x - y)g(y)$$

and therefore

$$\|f(-i\nabla)g(x)\|_{\mathfrak{S}_2}^2 = \int_{\mathbb{R}^6} |\check{f}(x - y)g(y)|^2 dx dy = (2\pi)^{-3} \|f\|_{L^2} \|g\|_{L^2}$$

For the second, we first note that, if $f \in \ell^2(\mathcal{R}^*)$ and $g \in L^2_{\text{per}}$, then $f(-i\nabla)g(x)$ is an operator on L^2_{per} . By writing its kernel (matrix in the basis of the $\frac{1}{\sqrt{|\Gamma|}}e^{iKx}$ for $K \in \mathcal{R}^*$), we get

$$\|f(-i\nabla)g(x)\|_{\mathfrak{S}_2(L^2_{\text{per}})} = \frac{1}{\sqrt{|\Gamma|}} \|f\|_{\ell^2(\mathcal{R}^*)} \|g\|_{L^2_{\text{per}}}$$

(see [12]). The result then follows by writing, for $f \in L^2, g \in L^2_{\text{per}}$,

$$\begin{aligned} \|f(-i\nabla)g(x)\|_{\mathfrak{S}_{2,\text{per}}}^2 &= \int_{\mathcal{B}} \|f(-i\nabla + k)g(x)\|_{\mathfrak{S}_2(L^2_{\text{per}})}^2 dk \\ &= \frac{1}{|\Gamma|} \|g\|_{L^2_{\text{per}}}^2 \int_{\mathcal{B}} \sum_{K \in \mathcal{R}^*} |f(k + K)|^2 dk = (2\pi)^{-3} \|g\|_{L^2_{\text{per}}}^2 \|f\|_{L^2}^2 \end{aligned}$$

□

In particular, since $f(q) = (1 + |q|^2)^{-1}$ is in L^2 , this implies that $(1 - \Delta)^{-1}V$ is bounded for $V \in L^2 + L^2_{\text{per}}$. This can be amplified to prove that both L^2 and L^2_{per} potentials are $-\Delta$ -bounded with relative bound zero, so that, for $V \in L^2 + L^2_{\text{per}}$, $-\Delta + V$ is self-adjoint on $L^2(\mathbb{R}^3)$ with domain $H^2(\mathbb{R}^3)$. In particular, the resolvent of $-\Delta + V$ is the resolvent of the Laplacian, modulo a bounded operator:

Lemma 3.6. *There is $C > 0$ such that, for all $V \in L^2 + L^2_{\text{per}}$, if $z \notin \sigma(-\Delta + V)$, then*

$$(11) \quad B_z = (z - H)^{-1}(1 - \Delta)$$

is bounded, with

$$\|B_z\| \leq C \left(1 + \frac{1 + |z| + \|V\|_{L^2 + L^2_{\text{per}}}^4}{d(z, \sigma(H))} \right).$$

Proof. In this proof and others in the sequel, C denotes a constant whose value might change from line to line.

The following argument is classical, see e.g. [3, Lemma 1]. The idea of the proof is that, if V is small, we can expand $(z - H)^{-1}(1 - \Delta) = \sum_{n \geq 0} ((z + \Delta)^{-1}V)^n (z + \Delta)^{-1}(1 - \Delta)$ and bound $(z + \Delta)^{-1}V$ by the Kato-Seiler-Simon equality. To extend this argument for arbitrary large sizes of V , we consider the shifted operator $H + ic$, where $c > 0$.

Let $c > 0$. For $V \in L^2$, we have that

$$\|(-\Delta - ic)^{-1}V\| \leq \|(-\Delta - ic)^{-1}V\|_{\mathfrak{S}_2} \leq \|V\|_{L^2} \|(|\xi|^2 - ic)^{-1}\|_{L^2} \leq c^{-1/4} \|V\|_{L^2} \|(|\xi|^2 - i)^{-1}\|_{L^2}$$

while similarly for $W \in L^2_{\text{per}}$ we have

$$\|(-\Delta - ic)^{-1}W\| \leq \|(-\Delta - ic)^{-1}W\|_{\mathfrak{S}_{2,\text{per}}} \leq \|W\|_{L^2_{\text{per}}} \|(|K|^2 - ic)^{-1}\|_{\ell^2} \leq c^{-1/4} \|W\|_{L^2_{\text{per}}} \|(|K|^2 - i)^{-1}\|_{\ell^2}$$

It follows that by taking $c = C(1 + |z| + \|V\|_{L^2 + L^2_{\text{per}}}^4)$ with C large enough, we get

$$(z - (H + ic))^{-1} = ((-\Delta - ic) + z - V)^{-1} = (1 + (-\Delta - ic)^{-1}(z - V))^{-1}(-\Delta - ic)^{-1}$$

and so $(z - (H + ic))^{-1}(1 - \Delta)$ is bounded uniformly in V and z . The result then follows from

$$\begin{aligned} B_z &= (z - H)^{-1}(z - (H + ic))(z - (H + ic))^{-1}(1 - \Delta) \\ \|B_z\| &\leq C \sup_{\lambda \in \mathbb{R}} \frac{|z - (\lambda + ic)|}{z - \lambda} \leq C \left(1 + \frac{c}{d(z, \sigma(H))} \right) \end{aligned}$$

□

3.3. Density of an operator. The following lemma gives a useful condition for an operator to have a density in L^2 , or for a periodic operator to have a density in L^2_{per} .

Lemma 3.7. *There is $C > 0$ such that, if A is an operator such that $A(1 - \Delta) \in \mathfrak{S}_2$, then $A(x, x) \in L^2$, with*

$$\|A(x, x)\|_{L^2} \leq C \|A(1 - \Delta)\|_{\mathfrak{S}_2} \|f\|_{L^2}$$

Similarly, if A_{per} is a periodic operator such that $A_{\text{per}}(1 - \Delta) \in \mathfrak{S}_{2, \text{per}}$, then $A_{\text{per}}(x, x) \in L^2_{\text{per}}$.

$$\|A(x, x)\|_{\mathfrak{S}_{1, \text{per}}} \leq C \|A_{\text{per}}(1 - \Delta)\|_{\mathfrak{S}_{2, \text{per}}}.$$

Proof. By the Kato-Seiler-Simon equality, for any function $f \in L^2$,

$$\|Af\|_{\mathfrak{S}_1} \leq \|A(1 - \Delta)\|_{\mathfrak{S}_2} \|(1 - \Delta)^{-1}f\|_{\mathfrak{S}_2} \leq C \|A(1 - \Delta)\|_{\mathfrak{S}_2} \|f\|_{L^2},$$

and similarly in the periodic case. \square

4. THE PERIODIC FINITE-TEMPERATURE RHF MODEL

Given a nuclear potential $W_{\text{nucl}} \in L^2_{\text{per}}$, we look for a solution of the equations

$$(12) \quad \begin{cases} W = W_{\text{nucl}} + v_{\text{per}} F_{\varepsilon_F}(W) \\ \int_{\Gamma} F_{\varepsilon_F}(W) = N_{\text{el}}. \end{cases}$$

Recall that the existence and uniqueness of solutions of this equation have been proved in [19]. Our goal for this section is Theorem 1.1, which states the local convergence of a fixed-point iteration.

For any $\rho \in L^2_{\text{per}}$, $v_{\text{per}}\rho$ was defined in (2) as the solution of the periodic Poisson equation with zero mean:

$$(v_{\text{per}}\rho)(x) = \sum_{K \in \mathcal{R}^*, K \neq 0} \frac{c_K(\rho)}{|K|^2} e^{iKx}.$$

It is a bounded non-negative self-adjoint operator on L^2_{per} . It is the pseudo-inverse of the negative Laplacian on L^2_{per} , in the sense that $-\Delta(v_{\text{per}}\rho) = \rho$ for all $\rho \in L^2$, and $v_{\text{per}}e = 0$, where the constant function e spans the kernel of $-\Delta$.

We first investigate the mapping F_{ε_F} and its derivative. The last property that $F'_{\varepsilon_F}(W) + \beta\Delta$ is positive for all $\beta > 0$ is recorded for future use in the case of defects.

Lemma 4.1. *For all $\varepsilon_F \in \mathbb{R}$, the map*

$$F_{\varepsilon_F}(W) = f_{\varepsilon_F}(-\Delta + W)(x, x)$$

is analytic from L^2_{per} to itself. For all $W \in L^2_{\text{per}}$, its differential $F'_{\varepsilon_F}(W)$ is self-adjoint and non-positive. Furthermore, for every $\beta > 0$, $F'_{\varepsilon_F}(W) + \beta\Delta$ is negative.

Proof. Step 1: $F_{\varepsilon_F} : L^2_{\text{per}} \mapsto L^2_{\text{per}}$. Let $W \in L^2_{\text{per}}$, and $H = -\Delta + W$. Recall that H is periodic, with fibers $H_k = (-i\nabla + k)^2 + W$. We label the eigenvectors and eigenvalues of H_k (a self-adjoint operator on L^2_{per} with compact resolvent) by

$$H_k u_{nk} = \varepsilon_{nk} u_{nk}$$

where the $(\varepsilon_{nk})_{n \in \mathbb{N}}$ are ordered by increasing order. We have

$$F_{\varepsilon_F}(W) = \int_{\mathcal{B}} \sum_{n \in \mathbb{N}} f_{\varepsilon_F}(\varepsilon_{nk}) |u_{nk}|^2 dk$$

By standard comparison arguments, there are $a \in \mathbb{R}, b > 0$ such that $\varepsilon_{nk} \geq a + bn^{2/3}$. By the Sobolev embedding $H^1_{\text{per}} \hookrightarrow L^4_{\text{per}}$, $|u_{nk}|^2$ is controlled in L^2_{per} by $\|u_{nk}\|_{H^1_{\text{per}}}^2 \leq C(1 + n^{2/3})$ for some $C > 0$, uniformly in $k \in \mathcal{B}$, and it follows from the exponential decay of f_{ε_F} that $F_{\varepsilon_F}(W) \in L^2_{\text{per}}$.

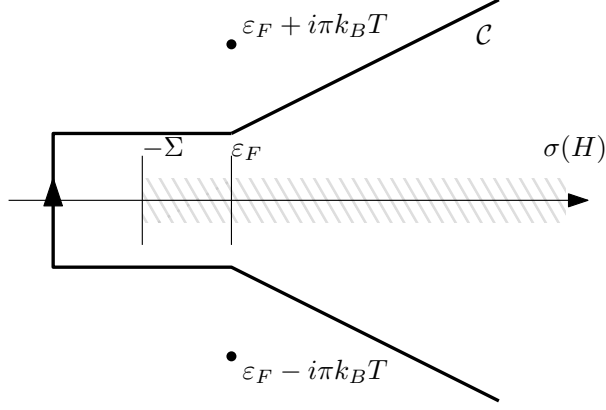

FIGURE 1. Contour \mathcal{C} used to differentiate the potential-to-density mapping. Note that this differs from standard rectangular contours because we need to ensure that $(z - H)^{-1}$ remains Hilbert-Schmidt uniformly in $z \in \mathcal{C}$.

Step 2: F_{ε_F} is analytic. Since potentials in L^2_{per} are infinitesimally Δ -bounded, there is $\Sigma > 0$ such that $\sigma(H) \subset [-\Sigma, +\infty)$ for all W with $\|W\|_{L^2_{\text{per}}} \leq R$. Let \mathcal{C} be the contour given by Figure 1. This contour encloses the spectrum of $\sigma(H)$, avoids the poles of the Fermi-Dirac function at $\varepsilon_F + i\pi k_B T + 2i\pi k_B T\mathbb{Z}$, and is asymptotic to $\text{Im}(z) = a \pm b \text{Re}(z)$ for large $z \in \mathcal{C}$, for some $a \in \mathbb{R}, b > 0$. The function f_{ε_F} is therefore analytic inside \mathcal{C} , decays exponentially when $|z| \rightarrow \infty$, and we have

$$f_{\varepsilon_F}(H) = \frac{1}{2\pi i} \int_{\mathcal{C}} f_{\varepsilon_F}(z)(z - H)^{-1} dz$$

as bounded operators². Let $R_z = (z - H)^{-1}$. Because $d(z, \sigma(H))$ increases at the same rate as $\text{Re}(z)$, it follows from Lemma 3.6 that $B_z = R_z(1 - \Delta)$ is bounded in operator norm, independently of $z \in \mathcal{C}$ (note that this would not be true for a rectangular contour). From the Kato-Seiler-Simon equality, there is therefore $C > 0$ such that, for all $z \in \mathcal{C}, \delta W \in L^2_{\text{per}}$,

$$\|R_z \delta W\|_{\mathfrak{S}_{2,\text{per}}} \leq \|B_z\| \|(1 - \Delta)^{-1} \delta W\|_{\mathfrak{S}_{2,\text{per}}} \leq C \|\delta W\|_{L^2_{\text{per}}}.$$

Therefore, for $\|\delta W\|_{L^2_{\text{per}}} \leq \frac{1}{2C}$, for all $z \in \mathcal{C}$, $(z - H - \delta W)$ is invertible, and

$$(z - H - \delta W)^{-1} = (1 - R_z \delta W)^{-1} R_z = \sum_{n \geq 0} (R_z \delta W)^n R_z.$$

We can expand $f_{\varepsilon_F}(H + \delta W)$ as bounded operators:

$$f_{\varepsilon_F}(H + \delta W) - f_{\varepsilon_F}(H) = \frac{1}{2\pi i} \int_{\mathcal{C}} f_{\varepsilon_F}(z) \sum_{n \geq 1} (R_z \delta W)^n R_z dz.$$

For all $n \geq 1$, we have that

$$\|(R_z \delta W)^n R_z (1 - \Delta)\|_{\mathfrak{S}_{2,\text{per}}} \leq \|B_z\| \|R_z \delta W\|_{\mathfrak{S}_{2,\text{per}}}^n \leq C^n \|\delta W\|_{L^2_{\text{per}}}^n.$$

It follows from the decay properties of f_{ε_F} on \mathcal{C} that

$$\int_{\mathcal{C}} \sum_{n \geq 1} f_{\varepsilon_F}(z) \|(R_z \delta W)^n R_z (1 - \Delta)\|_{\mathfrak{S}_{2,\text{per}}} < \infty,$$

and therefore that F_{ε_F} is analytic at W .

²Note that if other occupation functions are used, the contour may need to be modified. For instance, Gaussian smearing [5] decays exponentially only if $b < 1$. Our technique is less general than that of [19] based on the Helffer-Sjöstrand formula, which does not require any analyticity in f_{ε_F} .

Step 3: F'_{ε_F} is self-adjoint and non-positive. From the previous computations, we have

$$F'_{\varepsilon_F}(W) \cdot \delta W = \frac{1}{2\pi i} \int_{\mathcal{C}} f_{\varepsilon_F}(z) (R_z \delta W R_z)(x, x) dz.$$

with $(R_z \delta W R_z)(x, x) \in L^2_{\text{per}}$ uniformly in $z \in \mathcal{C}$.

For all $z \in \mathcal{C}$, $R_z \delta W R_z$ is periodic with fibers $(z - H_k)^{-1} W (z - H_k)^{-1}$. Inserting the spectral $(z - H_k)^{-1} = \sum_{n \in \mathbb{N}} (z - \varepsilon_{nk})^{-1} |u_{nk}\rangle \langle u_{nk}|$, we get, for all $\delta W_1, \delta W_2 \in L^2_{\text{per}}$,

$$\begin{aligned} & \langle \delta W_1, F'_{\varepsilon_F}(W) \cdot \delta W_2 \rangle \\ &= \frac{1}{2\pi i} \int_{\mathcal{C}} f_{\varepsilon_F}(z) \int_{\mathcal{B}} \sum_{n, m \in \mathbb{N}} \frac{1}{(z - \varepsilon_{nk})(z - \varepsilon_{mk})} \text{Tr} \left(\overline{\delta W_1} |u_{nk}\rangle \langle u_{nk}, \delta W_2 u_{mk}\rangle \langle u_{mk}| \right) dk dz. \\ &= \frac{1}{2\pi i} \int_{\mathcal{C}} f_{\varepsilon_F}(z) \int_{\mathcal{B}} \sum_{n, m \in \mathbb{N}} \frac{1}{(z - \varepsilon_{nk})(z - \varepsilon_{mk})} \langle \delta W_1 u_{mk}, u_{nk}\rangle \langle u_{nk}, \delta W_2 u_{mk}\rangle dk dz. \end{aligned}$$

The absolute convergence of this sum in L^2_{per} follows from the estimates above. For completeness, we give a more direct proof. Let $e_K(x) = \frac{e^{iKx}}{\sqrt{|\Gamma|}}$. The $(e_K)_{K \in \mathcal{R}^*}$ form a Hilbert basis of L^2_{per} , and we have the property $\langle e_K, \delta W e_{K'} \rangle = \frac{1}{\sqrt{|\Gamma|}} \langle e_{K-K'}, \delta W \rangle$ for all $\delta W \in L^2, K, K' \in \mathcal{R}^*$. It follows that

$$\begin{aligned} \sum_{n, m \in \mathbb{N}} \frac{|\langle u_{nk}, \delta W u_{mk}\rangle|^2}{|z - \varepsilon_{nk}|^2} &= \sum_{n, m \in \mathbb{N}, K, K' \in \mathcal{R}^*} \frac{|\langle u_{nk}, e_K\rangle \langle e_K, \delta W e_{K'}\rangle \langle e_{K'}, u_{mk}\rangle|^2}{|z - \varepsilon_{nk}|^2} \\ &= \frac{1}{|\Gamma|} \sum_{n \in \mathbb{N}, K, K' \in \mathcal{R}^*} \frac{|\langle u_{nk}, e_K\rangle \langle e_{K-K'}, \delta W \rangle|^2}{|z - \varepsilon_{nk}|^2} \\ &= \frac{\|\delta W\|_{L^2_{\text{per}}}^2}{|\Gamma|} \sum_{n \in \mathbb{N}, K \in \mathcal{R}^*} \frac{|\langle u_{nk}, e_K\rangle|^2}{|z - \varepsilon_{nk}|^2} \\ &= \frac{\|\delta W\|_{L^2_{\text{per}}}^2}{|\Gamma|} \sum_{n \in \mathbb{N}} \frac{1}{|z - \varepsilon_{nk}|^2} \end{aligned}$$

which is bounded uniformly in $k \in \mathcal{B}, z \in \mathcal{C}$. The result follows by a Cauchy-Schwarz inequality. Performing the contour integration, we obtain the following sum-over-states formula

$$\langle \delta W_1, F'_{\varepsilon_F}(W) \cdot \delta W_2 \rangle = \int_{k \in \mathcal{B}} \sum_{n, m \in \mathbb{N}} \frac{f_{nk} - f_{mk}}{\varepsilon_{nk} - \varepsilon_{mk}} \langle \delta W_1 u_{mk}, u_{nk}\rangle \langle u_{nk}, \delta W_2 u_{mk}\rangle dk$$

where $f_{nk} = f_{\varepsilon_F}(\varepsilon_{nk})$, and with the convention that

$$\frac{f_{\varepsilon_F}(\varepsilon) - f_{\varepsilon_F}(\varepsilon)}{\varepsilon - \varepsilon} = f'_{\varepsilon_F}(\varepsilon)$$

arising from the double pole $(z - \varepsilon_{mk})^{-2}$ when $\varepsilon_{nk} = \varepsilon_{mk}$. $F'_{\varepsilon_F}(W)$ is therefore self-adjoint and, since

$$\langle \delta W, F'_{\varepsilon_F}(W) \cdot \delta W \rangle = \int_{k \in \mathcal{B}} \sum_{n, m \in \mathbb{N}} \frac{f_{nk} - f_{mk}}{\varepsilon_{nk} - \varepsilon_{mk}} |\langle u_{nk}, \delta W u_{mk}\rangle|^2 dk$$

and f_{ε_F} is decreasing, it follows that $F'_{\varepsilon_F}(W)$ is non-positive.

Step 4: $F'_{\varepsilon_F}(W) + \beta \Delta$ is negative. Assume that $F'_{\varepsilon_F}(W) + \beta \Delta$ is not negative. This means that there exists a sequence W_n of potentials with $\|W_n\|_{L^2_{\text{per}}} = 1$ such that

$$\langle W_n, F'_{\varepsilon_F}(W) \cdot W_n \rangle - \beta \int_{\Gamma} |\nabla W_n|^2 \rightarrow 0.$$

Let e be the constant function in L^2_{per} . We have $\sum_{K \neq 0} |K|^2 |c_K(W_n)|^2 \rightarrow 0$, so that $P_e^\perp W_n \rightarrow 0$ in H^1 . Up to a subsequence, we can assume that $\langle e, W_n \rangle \rightarrow c$, with $c \in \mathbb{C}$. It follows from $W_n = P_e W_n + P_e^\perp W_n$ that $W_n \rightarrow ce$ in L^2 , and that $|c| = \frac{1}{\sqrt{|\Gamma|}}$. Then,

$$\begin{aligned} \langle W_n, F'_{\varepsilon_F}(W) \cdot W_n \rangle &\leq \int_{k \in \mathcal{B}} f'_{\varepsilon_F}(\varepsilon_{1k}) |\langle u_{1k}, W_n u_{1k} \rangle|^2 dk \\ &\rightarrow \frac{1}{\sqrt{|\Gamma|}} \int_{k \in \mathcal{B}} f'_{\varepsilon_F}(\varepsilon_{1k}) dk < 0. \end{aligned}$$

where we have used that $\| |u_{1k}|^2 \|_{L^2} \leq C \|u_{1k}\|_{H^1}^2$ is bounded uniformly in k . \square

4.1. Self-consistent Fermi level. We now solve the equation $\int_\Gamma F_{\varepsilon_F}(W) = N_{\text{el}}$ for ε_F .

Lemma 4.2. *For all $W \in L^2_{\text{per}}$ and $N_{\text{el}} > 0$, the equation $\int_\Gamma F_{\varepsilon_F}(W) = N_{\text{el}}$ has a unique solution $\varepsilon_F(W)$. The map*

$$F(W) = F_{\varepsilon_F(W)}(W)$$

is analytic from L^2_{per} to L^2_{per} . Its differential $F'(W)$ is self-adjoint and non-positive, and satisfies $F'(W) \cdot e = 0$ where e is the constant function.

Proof. Let

$$\mathcal{N}(\varepsilon_F, W) = \langle e, F_{\varepsilon_F}(W) \rangle = \int_{\mathcal{B}} \sum_{n \in \mathbb{N}} f_{\varepsilon_F}(\varepsilon_{nk}) dk$$

be the total number of electrons with Fermi level ε_F . Then, since $F_{\varepsilon_F}(W) = F(W - \varepsilon_F e)$, by the previous lemma \mathcal{N} is analytic on $\mathbb{R} \times L^2_{\text{per}}$, with

$$\begin{aligned} \frac{\partial \mathcal{N}}{\partial \varepsilon_F}(\varepsilon_F, W) &= -\langle e, F'_{\varepsilon_F}(W) \cdot e \rangle = - \int_{\mathcal{B}} \sum_{n \in \mathbb{N}} f'_{\varepsilon_F}(\varepsilon_{nk}) dk > 0 \\ \frac{\partial \mathcal{N}}{\partial W}(\varepsilon_F, W) \cdot \delta W &= \langle e, F'_{\varepsilon_F}(W) \cdot \delta W \rangle = \langle F'_{\varepsilon_F}(W) \cdot e, \delta W \rangle \end{aligned}$$

For all $W \in L^2_{\text{per}}$, $\mathcal{N}(\cdot, W)$ has limit 0 at $-\infty$ and $+\infty$ at $+\infty$, so that there is a unique solution $\varepsilon_F(W)$ of $\mathcal{N}(\varepsilon_F, W) = N_{\text{el}}$. From the implicit function theorem, we get that $\varepsilon_F(W)$ is analytic on L^2_{per} and

$$\varepsilon'_F(W) \cdot \delta W = \frac{1}{\langle e, F'_{\varepsilon_F}(W) \cdot e \rangle} \langle F'_{\varepsilon_F}(W) \cdot e, \delta W \rangle$$

and therefore

$$F'(W) \cdot \delta W = F'_{\varepsilon_F}(W) \cdot \delta W - \frac{1}{\langle e, F'_{\varepsilon_F}(W) \cdot e \rangle} \langle F'_{\varepsilon_F}(W) \cdot e, \delta W \rangle F'_{\varepsilon_F}(W) \cdot e$$

In particular, $F'(W) \cdot e = 0$ and $F'(W)$ is self-adjoint.

The expression above is of the form $F'(W) = A - \frac{1}{\langle e, Ae \rangle} |Ae\rangle \langle Ae|$, with $A = F'_{\varepsilon_F}(W)$ bounded, self-adjoint and non-positive on a Hilbert space \mathcal{H} and $e \in \mathcal{H}$. In particular, $F'(W)$ is self-adjoint, $F'(W) \cdot e = 0$, and we compute, for all $x \in \mathcal{H}$,

$$\left\langle x, \left(A - \frac{1}{\langle e, Ae \rangle} |Ae\rangle \langle Ae| \right) x \right\rangle = - \left(\| |A|^{1/2} x \|^2 - \frac{|\langle |A|^{1/2} x, |A|^{1/2} e \rangle|^2}{\| |A|^{1/2} e \|^2} \right) \leq 0$$

by the Cauchy-Schwartz inequality, from where it follows that $F'(W)$ is non-positive. \square

We now look for solutions $W \in L^2_{\text{per}}$ of the equation

$$W = W_{\text{nucl}} + v_{\text{per}} F(W).$$

We are ready for the

Proof of Theorem 1.1. Set

$$T_\alpha(W, W_{\text{nucl}}) = W + \alpha(W_{\text{nucl}} + v_{\text{per}}F(W) - W)$$

In particular, T_α is analytic from L_{per}^2 to itself. From Theorem 3.3, we only need to check that the spectral radius of the operator

$$J_\alpha = 1 + \alpha(v_{\text{per}}F'(W^*) - 1)$$

is smaller than 1 for α small enough. This is ensured by the fact that v_{per} and $F'(W^*)$ are bounded operators on L_{per}^2 and v_{per} is non-negative, so that, from Lemma 3.1,

$$\sigma(v_{\text{per}}F'(W^*)) \setminus \{0\} = \sigma(\sqrt{v_{\text{per}}}F'(W^*)\sqrt{v_{\text{per}}}) \setminus \{0\}$$

This last operator is a non-positive self-adjoint bounded operator on L_{per}^2 , hence the result. \square

5. THE DEFECT PROBLEM

In this section we fix $W_{\text{per}} \in L_{\text{per}}^2$ and $\varepsilon_F \in \mathbb{R}$. Let

$$H_{\text{per}} = -\Delta + W_{\text{per}}$$

be the background periodic Hamiltonian.

We first investigate the renormalized potential-to-density mapping.

Lemma 5.1. *There is a neighborhood \mathcal{V} of 0 in L^2 in which the map*

$$G(V) = (f_{\varepsilon_F}(H_{\text{per}} + V) - f_{\varepsilon_F}(H_{\text{per}}))(x, x)$$

is analytic from L_N^2 to L_N^2 for all $N \geq 0$.

Let $\chi_0 = G'(0)$. Then $V \mapsto G(V) - \chi_0 V$ maps $\mathcal{V} \cap L_N^2$ to L_{2N}^2 for all $N \geq 0$.

Proof. Step 1: the case $N = 0$. The proof of this step is similar to that of Lemma 4.1. We take a contour \mathcal{C} enclosing the spectrum of H_{per} with the same shape as in Figure 1, which encloses the spectrum of $H_{\text{per}} + V$ for $\|V\|_{L^2}$ small because L^2 potentials are infinitesimally Δ -bounded. From Lemma 3.6, there is $C > 0$ such that, for all $z \in \mathcal{C}$ and $V \in L^2$,

$$\|R_z V\|_{\mathfrak{S}_2} = \|R_z(1 - \Delta)(1 - \Delta)^{-1}V\|_{\mathfrak{S}_2} \leq C\|V\|_{L^2}.$$

with $R_z = (z - H_{\text{per}})^{-1}$. It follows that, for $\|V\|_{L^2} \leq \frac{1}{2C}$, $(1 - R_z V)$ is invertible, and we have

$$\begin{aligned} f_{\varepsilon_F}(H_{\text{per}} + V) - f_{\varepsilon_F}(H_{\text{per}}) &= \frac{1}{2\pi i} \int_{\mathcal{C}} f_{\varepsilon_F}(z) \left((z - (H_{\text{per}} + V))^{-1} - (z - H_{\text{per}})^{-1} \right) dz \\ (13) \qquad \qquad \qquad &= \frac{1}{2\pi i} \int_{\mathcal{C}} f_{\varepsilon_F}(z) \sum_{n \geq 1} (R_z V)^n R_z dz \end{aligned}$$

as bounded operators. From the estimate

$$\|(R_z V)^{n-1} R_z V R_z (1 - \Delta)\|_{\mathfrak{S}_2} \leq \|R_z(1 - \Delta)\| \|R_z V\|_{\mathfrak{S}_2}^n \leq C^n \|V\|_{L^2}^n$$

with C uniform in $z \in \mathcal{C}$ and the decay properties of f_{ε_F} , it follows that the expansion (13) converges absolutely. Therefore, $f_{\varepsilon_F}(H_{\text{per}} + V) - f_{\varepsilon_F}(H_{\text{per}})$ can be associated a density $G(V) \in L^2$, and G is analytic in a neighborhood of 0.

Step 2: Bloch structure of the expansion of the density at all orders. We first note that

$$H_{k+q} - H_k = 2(-i\nabla + k) \cdot q + |q|^2.$$

The bounded operator $R_z = (z - H)^{-1}$ on L^2 is periodic with fibers $R_{z,k} = (z - H_k)^{-1}$. Since $R_{z,k}(1 - \Delta)$ is bounded uniformly in $z \in \mathcal{C}$ and $k \in \mathcal{B}$,

$$\|R_{z,k}(2(-i\nabla + k) \cdot q + |q|^2)\| = \|R_{z,k}(1 - \Delta)(1 - \Delta)^{-1}(2(-i\nabla + k) \cdot q + |q|^2)\| \leq C(|q| + |q|^2).$$

For q small enough, we then have

$$R_{z,k+q} = \sum_{n \geq 0} \left(R_{z,k} (2(-i\nabla + k) \cdot q + |q|^2) \right)^n R_{z,k}$$

and, from the previous estimate, $R_{z,k}$ is analytic in the $\|\cdot(1-\Delta)\|_{\mathfrak{S}_{2,\text{per}}}$ topology, uniformly in $z \in \mathcal{C}$ and $k \in \mathcal{B}$.

For $z \in \mathcal{C}$, let

$$D_z^{(n)}(V) = ((R_z V)^n R_z)(x, x).$$

We first consider the first-order term $D_z^{(1)}$. Let $V = \int_{\mathcal{B}} e^{iqx} V_q(x) dq \in L^2$. Elementary computations show that if A is a periodic operator with fibers A_k , then $e^{-iqx} A e^{iqx}$ is a periodic operator with fibers A_{k+q} , and that $e^{iqx} A$ has density

$$(e^{iqx} A)(x, x) = e^{iqx} A(x, x) = e^{iqx} \int_{\mathcal{B}} A_k(x, x) dk.$$

Therefore,

$$\begin{aligned} D_z^{(1)}(V) &= \int_{\mathcal{B}} (e^{iqx} e^{-iqx} R_z e^{iqx} V_q R_z)(x, x) dq = \int_{\mathcal{B}} e^{iqx} \int_{\mathcal{B}} (R_{z,k+q} V_q R_{z,k})(x, x) dk dq \\ D_z^{(1)}(V)_q &= \int_{\mathcal{B}} (R_{z,k+q} V_q R_{z,k})(x, x) dk. \end{aligned}$$

Similarly, in the general case,

$$(14) \quad D_z^{(n)}(V)_q = \int_{q_1, \dots, q_{n-1} \in \mathcal{B}} \int_{k \in \mathcal{B}} (R_{z,k+q} V_{q-q_1} R_{z,k+q_1} V_{q_1-q_2} \cdots R_{z,k})(x, x) dk dq_1 \cdots dq_n$$

Step 3: the case $N > 0$. Since for $i = 1, 2, 3$

$$(15) \quad (x_i D_z^{(n)}(V))_q = i \partial_{q_i} D_z^{(n)}(V)_q$$

and $R_{z,k}$ is analytic for the $\|\cdot(1-\Delta)\|_{\mathfrak{S}_{2,\text{per}}}$ topology, uniformly in $z \in \mathcal{C}, k \in \mathcal{B}$, the repeated application of (15) to (14) yields a bound of the form

$$\|D_z^{(n)}(V)\|_{L_N^2} \leq C_N \|V\|_{L_N^2} C^{n-1} \|V\|_{L^2}^{n-1}$$

for all $N \geq 0$, with C independent on N , this bound being uniform in $z \in \mathcal{C}$.

It follows that, for $\|V\|_{L^2} \leq \frac{1}{2C}$, for all N , we have the absolutely convergent expansion

$$G(V) = \frac{1}{2\pi i} \int_{\mathcal{C}} f_{\varepsilon_F}(z) \sum_{n \geq 1} D_z^{(n)}(V) dz$$

in L_N^2 .

Step 4: $G(V) - \chi_0 V : L_N^2 \mapsto L_{2N}^2$. We have

$$G(V) - \chi_0 V = \frac{1}{2\pi i} \int_{\mathcal{C}} f_{\varepsilon_F}(z) \sum_{n \geq 2} D_z^{(n)}(V) dz.$$

Consider terms of the form

$$(16) \quad I = \int_{q_1, \dots, q_{n-1} \in \mathcal{B}} \int_{k \in \mathcal{B}} (R_{z,k+q}^{(1)} V_{q-q_1}^{(1)} R_{z,k+q_1}^{(2)} V_{q_1-q_2}^{(2)} R_{z,k+q_2} V_{q_2-q_3} \cdots R_{z,k})(x, x) dk dq_1 \cdots dq_n$$

where $R_{z,k}^{(1)}, R_{z,k}^{(2)}$ are $R_{z,k}$ or their derivatives, and $V_q^{(1)}, V_q^{(2)}$ are V_q or its derivatives. These terms have the form of a periodic convolution and their q derivatives can be expressed with respect to either $V^{(1)}$ or $V^{(2)}$. Indeed, $q_1 \mapsto V_{q-q_1}^{(1)} R_{z,k+q_1}^{(2)} V_{q_1-q_2}^{(2)}$ is \mathcal{R}^* -periodic. Performing the

change of variable $q'_1 = q - q_1$ and using the periodicity to integrate q'_1 over \mathcal{B} rather than $q - \mathcal{B}$, we can transfer the q dependence on $V^{(2)}$:

(17)

$$I = - \int_{q'_1, \dots, q_{n-1} \in \mathcal{B}} \int_{k \in \mathcal{B}} (R_{z, k+q}^{(1)} V_{q'_1}^{(1)} R_{z, k+q-q'_1}^{(2)} V_{q-q'_1-q_2}^{(2)} R_{z, k+q_2} V_{q_2-q_3} \cdots R_{z, k})(x, x) dk dq'_1 \cdots dq_n.$$

Let p_{2N} be a polynomial of degree $2N$. Applying (15) successively to $p_{2N}(x)(G(V) - \chi_0 V)$ involves terms of the form (16), which can be rewritten using (17) to contain at most N derivatives of $V_q^{(1)}$ and $V_q^{(2)}$ with respect to q . Using the analyticity of $k \mapsto R_{z, k}$, we obtain a bound of the form

$$\|D_z^{(n)}(V)\|_{L_{2N}^2} \leq C_N \|V\|_{L_N^2}^{n-2} \|V\|_{L^2}^{2-n}$$

where C is independent of N , the bound being uniform in $z \in \mathcal{C}$. The result follows. \square

Recall that the operator v_c is given by the convolution

$$(v_c \rho)(x) = \frac{1}{4\pi} \int_{\mathbb{R}^3} \frac{\rho(y)}{|x-y|} dy.$$

In Fourier space, this is a multiplication by $\frac{1}{|q|^2}$. This is an unbounded non-negative self-adjoint operator on L^2 . We denote its formal inverse by $v_c^{-1} = -\Delta$, also an unbounded non-negative self-adjoint operator on L^2 . v_c^{-1} does not have a spectral gap at zero, but $-\chi_0 + v_c^{-1}$ does:

Lemma 5.2. *Let $N \geq 0$. The operator $-\chi_0 + v_c^{-1}$ is self-adjoint and positive on L^2 , and its inverse is bounded from H_N^{-2} to L_N^2 . The operator $\varepsilon = 1 - v_c \chi_0$ is invertible in L_N^2 , with bounded inverse*

$$\varepsilon^{-1} = (1 - v_c \chi_0)^{-1} = (-\chi_0 + v_c^{-1})^{-1} v_c^{-1}.$$

The operator $\mathcal{K}\varepsilon$ is therefore bounded and invertible on L_N^2 .

Proof. We have, for $V \in L^2$ with Bloch transform V_q

$$\chi_0 V = \frac{1}{2\pi i} \int_{\mathcal{C}} f_{\varepsilon_F}(z) \int_{\mathcal{B}} \int_{\mathcal{B}} (R_{z, k+q} V_q R_{z, k})(x, x) dk dq dz$$

and therefore χ_0 is fibered, with fibers

$$(18) \quad \chi_{0, q} W = \frac{1}{2\pi i} \int_{\mathcal{C}} f_{\varepsilon_F}(z) \int_{\mathcal{B}} (R_{z, k+q} W R_{z, k})(x, x) dk dz$$

for $W \in L_{\text{per}}^2$. As in Lemma 4.1, inserting the decomposition $R_{z, k} = \sum_{n \in \mathbb{N}} (z - \varepsilon_{nk})^{-1} |u_{nk}\rangle \langle u_{nk}|$, we obtain the sum-over-states formula

$$\langle W_1, \chi_{0, q} W_2 \rangle = \int_{\mathcal{B}} \sum_{n, m \geq 0} \frac{f_{n, k+q} - f_{m, k}}{\varepsilon_{n, k+q} - \varepsilon_{m, k}} \langle W_1 u_{m, k}, u_{nk+q} \rangle \langle u_{nk+q}, W_2 u_{m, k} \rangle dk$$

converging absolutely, from where it follows that $\chi_{0, q}$ is self-adjoint and non-positive on L^2 for all q , and therefore that χ_0 is too.

It follows from the regularity of $R_{z, k}$ and (18) that $\chi_{0, k}$ is analytic as bounded operators in L_{per}^2 , with $\chi_{0, 0} = F'_{\varepsilon_F}(W_{\text{per}})$. The operator $v_c^{-1} = -\Delta$ has fibers $v_{c, k}^{-1} = (-i\nabla + k)^2$ positive except at $k = 0$. Using Lemma 4.1 with $\beta = 1/2$, it follows that

$$-\chi_{0, k} + \frac{1}{2} v_{c, k}^{-1} = -(\chi_{0, k} - F'_{\varepsilon_F}(W_{\text{per}})) - F'_{\varepsilon_F}(W_{\text{per}}) + \frac{1}{2} v_{c, k}^{-1}$$

is bounded away from zero for k small, and therefore for all k . Therefore, there is $c > 0$ such that

$$-\chi_0 + v_c^{-1} = -\chi_0 + \frac{1}{2} v_c^{-1} + \frac{1}{2} v_c^{-1} \geq c(1 - \Delta)$$

as quadratic forms, from where it follows that $(-\chi_0 + v_c^{-1})^{-1} \leq \frac{1}{c}(1 - \Delta)^{-1}$ as quadratic forms and then that, for all $V \in L^2$, $\|(-\chi_0 + v_c^{-1})^{-1}V\|_{L^2} \leq \frac{1}{c}\|(1 - \Delta)^{-1}V\|_{L^2}$. The operator $(-\chi_0 + v_c^{-1})^{-1}$ is therefore bounded from H^{-2} to L^2 .

Its fibers are $(\chi_{0,k} + v_{c,k}^{-1})^{-1}$ and, for q small enough,

$$(\chi_{0,k+q} + v_{c,k}^{-1})^{-1} = \sum_{n \geq 0} \left((\chi_{0,k} + v_{c,k}^{-1})^{-1} (\chi_{0,k+q} - \chi_{0,k})^n \right) (\chi_{0,k} + v_{c,k}^{-1})^{-1}$$

which shows that the family $(\chi_0 + v_c^{-1})_k^{-1}$ is analytic on \mathcal{B} as operators from H_{per}^{-2} to L_{per}^2 , and therefore that $(\chi_0 + v_c^{-1})^{-1}$ is bounded from H_N^{-2} to L_N^2 . It then follows that ε is invertible on L_N^2 , with inverse

$$\varepsilon^{-1} = (1 - v_c \chi_0)^{-1} = (-\chi_0 + v_c^{-1})^{-1} v_c^{-1}.$$

Finally, we have

$$(\mathcal{K}\varepsilon)^{-1} = (-\chi_0 + v_c^{-1})^{-1} v_c^{-1} \mathcal{K}^{-1} = (-\chi_0 + v_c^{-1})^{-1} (1 - \Delta),$$

hence the result. \square

We are now ready for the

Proof of Theorem 1.2. We proceed as in Theorem 1.1, and apply Theorem 3.3 to

$$T(V, V_{\text{def}}) = V + \alpha \mathcal{K}(V_{\text{def}} + v_c G(V) - V),$$

analytic in a neighborhood of 0 in $L^2 \times v_c H^{-2}$ to L^2 , with Jacobian at $(0, 0)$

$$J_\alpha = 1 - \alpha \mathcal{K} + \alpha \mathcal{K} v_c \chi_0 = 1 - \alpha \mathcal{K} \varepsilon.$$

Since $\mathcal{K} v_c = (1 - \Delta)^{-1}$ is bounded, self-adjoint and non-negative on L^2 , we have

$$\sigma(\mathcal{K} v_c \chi_0) \setminus \{0\} = \sigma(\sqrt{\mathcal{K} v_c \chi_0} \sqrt{\mathcal{K} v_c}) \setminus \{0\}.$$

It follows that by taking α_0 small enough, we can impose that $\sigma(J_\alpha) \subset (-1, 1]$. Since from Lemma 5.2 the operator $\mathcal{K} \varepsilon$ is invertible on L^2 , we even have that $\sigma(J_\alpha) \subset (-1, 1)$, hence the result. \square

Proof of Theorem 1.3. The proof is based on a bootstrap argument on the equation

$$(19) \quad V = \varepsilon^{-1}(V_{\text{def}} + v_c(G(V) - \chi_0 V))$$

satisfied by $V(V_{\text{def}})$.

For the base case $N = 1$, we prove that $V(V_{\text{def}}) \in L_1^2$ by applying Theorem 3.3 to

$$T(V, V_{\text{def}}) = \varepsilon^{-1}(V_{\text{def}} + v_c(G(V) - \chi_0 V)),$$

an analytic map from $L_1^2 \times v_c H_1^{-2}$ to L_1^2 with Jacobian 0 at $(0, 0)$. It follows from the uniqueness of $V(V_{\text{per}})$ that $V(V_{\text{per}}) \in L_1^2$.

We then use the fact that $T(\cdot, V_{\text{def}})$ maps L_1^2 to L_2^2 to conclude from (19) that $V(V_{\text{per}}) \in L_2^2$. Repeating this argument, we obtain that $V(V_{\text{per}}) \in L_N^2$. \square

ACKNOWLEDGMENTS

Stimulating discussions with Eric Cancès, Thierry Deusch and Domenico Monaco are gratefully acknowledged.

REFERENCES

- [1] S.L. Adler. Quantum theory of the dielectric constant in real solids. *Physical Review*, 126(2):413, 1962.
- [2] M. Benzi, P. Boito, and N. Razouk. Decay properties of spectral projectors with applications to electronic structure. *SIAM review*, 55(1):3–64, 2013.
- [3] É. Cancès, A. Deleurence, and M. Lewin. A new approach to the modeling of local defects in crystals: The reduced Hartree-Fock case. *Communications in Mathematical Physics*, 281(1):129–177, 2008.
- [4] É Cancès and V. Ehrlacher. Local defects are always neutral in the Thomas–Fermi–von Weiszäcker theory of crystals. *Archive for rational mechanics and analysis*, 202(3):933–973, 2011.
- [5] É Cancès, V. Ehrlacher, D. Gontier, A. Levitt, and D. Lombardi. Numerical quadrature in the Brillouin zone for periodic Schrodinger operators. *arXiv preprint arXiv:1805.07144*, 2018.
- [6] É Cancès and C. Le Bris. On the convergence of SCF algorithms for the Hartree-Fock equations. *ESAIM: Mathematical Modelling and Numerical Analysis*, 34(4):749–774, 2000.
- [7] É. Cancès and M. Lewin. The dielectric permittivity of crystals in the reduced Hartree–Fock approximation. *Archive for Rational Mechanics and Analysis*, 197(1):139–177, 2010.
- [8] É Cancès and G. Stoltz. A mathematical formulation of the random phase approximation for crystals. *Annales de l’Institut Henri Poincaré (C) Non Linear Analysis*, 29(6):887–925, 2012.
- [9] I. Catto, C. Le Bris, and P-L Lions. On the thermodynamic limit for Hartree–Fock type models. *Annales de l’Institut Henri Poincaré (C) Non Linear Analysis*, 18(6):687–760, 2001.
- [10] H. Chen, J. Lu, and C. Ortner. Thermodynamic limit of crystal defects with finite temperature tight binding. *Archive for Rational Mechanics and Analysis*, 230(2):701–733, 2018.
- [11] R. Frank, M. Lewin, E. Lieb, and R. Seiringer. A positive density analogue of the Lieb–Thirring inequality. *Duke Mathematical Journal*, 162(3):435–495, 2013.
- [12] D. Gontier and S. Lahbabi. Supercell calculations in the reduced Hartree–Fock model for crystals with local defects. *Applied Mathematics Research eXpress*, 2017(1):1–64, 2016.
- [13] R.B. Holmes. A formula for the spectral radius of an operator. *The American Mathematical Monthly*, 75(2):163–166, 1968.
- [14] G.P. Kerker. Efficient iteration scheme for self-consistent pseudopotential calculations. *Physical Review B*, 23(6):3082, 1981.
- [15] A. Lechleiter. The Floquet–Bloch transform and scattering from locally perturbed periodic surfaces. *Journal of Mathematical Analysis and Applications*, 446(1):605–627, 2017.
- [16] A. Levitt. Convergence of gradient-based algorithms for the Hartree-Fock equations. *ESAIM: Mathematical Modelling and Numerical Analysis*, 46(6):1321–1336, 2012.
- [17] E. Lieb and B. Simon. The Thomas-Fermi theory of atoms, molecules and solids. *Advances in Mathematics*, 23(1):22–116, 1977.
- [18] F. Nazar and C. Ortner. Locality of the Thomas–Fermi–von Weiszäcker Equations. *Archive for Rational Mechanics and Analysis*, 224(3):817–870, 2017.
- [19] F. Nier. A variational formulation of Schrödinger-Poisson systems in dimension $d \leq 3$. *Communications in partial differential equations*, 18(7-8):1125–1147, 1993.
- [20] E. Prodan, S.R. Garcia, and M. Putinar. Norm estimates of complex symmetric operators applied to quantum systems. *Journal of Physics A: Mathematical and General*, 39(2):389, 2005.
- [21] M. Reed and B. Simon. Analysis of operators, vol. IV of Methods of modern mathematical physics, 1978.
- [22] Y. Saad. *Iterative methods for sparse linear systems*, volume 82. SIAM, 2003.
- [23] B. Simon. *Trace ideals and their applications*. American Mathematical Soc., 2010.
- [24] J-P Solovej. Proof of the ionization conjecture in a reduced Hartree-Fock model. *Inventiones mathematicae*, 104(1):291–311, 1991.
- [25] H. Walker and P. Ni. Anderson acceleration for fixed-point iterations. *SIAM Journal on Numerical Analysis*, 49(4):1715–1735, 2011.
- [26] N. Wiser. Dielectric constant with local field effects included. *Physical Review*, 129(1):62, 1963.