



HAL
open science

Uniform a priori estimates for elliptic problems with impedance boundary conditions

Théophile Chaumont-Frelet, Serge Nicaise, Jérôme Tomezyk

► **To cite this version:**

Théophile Chaumont-Frelet, Serge Nicaise, Jérôme Tomezyk. Uniform a priori estimates for elliptic problems with impedance boundary conditions. *Communications on Pure and Applied Analysis*, 2020, 10.3934/cpaa.2020107 . hal-01887269

HAL Id: hal-01887269

<https://hal.science/hal-01887269v1>

Submitted on 3 Oct 2018

HAL is a multi-disciplinary open access archive for the deposit and dissemination of scientific research documents, whether they are published or not. The documents may come from teaching and research institutions in France or abroad, or from public or private research centers.

L'archive ouverte pluridisciplinaire **HAL**, est destinée au dépôt et à la diffusion de documents scientifiques de niveau recherche, publiés ou non, émanant des établissements d'enseignement et de recherche français ou étrangers, des laboratoires publics ou privés.

UNIFORM A PRIORI ESTIMATES FOR ELLIPTIC PROBLEMS WITH IMPEDANCE BOUNDARY CONDITIONS

T. CHAUMONT-FRELET, S. NICAISE, AND J. TOMEZYK

ABSTRACT. We derive stability estimates in H^2 for elliptic problems with impedance boundary conditions that are uniform with respect to the impedance coefficient. Such estimates are of importance to establish sharp error estimates for finite element discretizations of contact impedance and high-frequency Helmholtz problems. Though stability in H^2 is easily obtained by employing a “bootstrap” argument and well-established result for the corresponding Neumann problem, this strategy leads to a stability constant that increases with the impedance coefficient. Here, we propose alternative proofs to derive sharp and uniform stability constants for domains that are convex or smooth.

1. INTRODUCTION

In this paper, we consider the following elliptic problem with impedance boundary conditions in a bounded domain Ω of \mathbb{R}^n , $n \in \{2, 3\}$:

$$(1.1) \quad \begin{cases} -\nabla \cdot (A \nabla u) = f & \text{in } \Omega, \\ A \nabla u \cdot \mathbf{n} + \xi u = 0 & \text{on } \Gamma_{\text{Diss}}, \\ u = 0 & \text{on } \Gamma_{\text{Dir}}, \end{cases}$$

where $f : \Omega \rightarrow \mathbb{C}$ is a given source term, and Γ_{Dir} and Γ_{Diss} are two disjoint open subsets of the boundary $\Gamma := \partial\Omega$ of Ω such that $\overline{\Gamma_{\text{Dir}}} \cup \overline{\Gamma_{\text{Diss}}} = \partial\Omega$. In addition, Γ_{Diss} is supposed to be non-empty, the matrix-valued function A is supposed to be symmetric with real coefficients, smooth enough ($C^{0,1}(\Omega, \mathbb{R}^{n \times n})$) and positive definite, i.e.,

$$X^\top A(\mathbf{x})X \geq \alpha_0 |X|^2, \forall X \in \mathbb{R}^n, \mathbf{x} \in \bar{\Omega},$$

and finally $\xi \in W^{1,\infty}(\Gamma_{\text{Diss}})$ is a complex valued function (that for instance plays the role of the angular frequency or the contact impedance according to the context) such that

$$(1.2) \quad \text{Re } \xi \geq 0 \text{ on } \Gamma_{\text{Diss}},$$

$$(1.3) \quad \text{Im } \xi \geq 0 \text{ on } \Gamma_{\text{Diss}} \text{ or } \text{Im } \xi \leq 0 \text{ on } \Gamma_{\text{Diss}},$$

$$(1.4) \quad |\xi| \geq c_b \text{ on } \Gamma_{\text{Diss}},$$

and finally

$$(1.5) \quad \frac{|\nabla_T \xi|}{|\xi|} \leq c_\# \text{ on } \Gamma_{\text{Diss}},$$

2010 *Mathematics Subject Classification.* Primary 35J05; Secondary 35B30.

Key words and phrases. Impedance boundary conditions; Uniform estimates.

for some two positive constants c_b and c_\sharp .

Such a problem occur in different applications like complete electrode models [7, 10, 11, 14], singularly perturbed radiation problem [6, 16], embedding of a quantum mechanically described structures into a macroscopic flow [12].

In addition, problem (1.1) with $A = I_n$ and a purely imaginary complex number $\xi = i\omega$, namely

$$(1.6) \quad \begin{cases} -\Delta u = f & \text{in } \Omega, \\ \nabla u \cdot \mathbf{n} - \frac{i\omega}{\mathcal{V}}u = 0 & \text{on } \Gamma_{\text{Diss}}, \\ u = 0 & \text{on } \Gamma_{\text{Dir}}, \end{cases}$$

was introduced in [8] (with $\mathcal{V} = 1$) in order to derive pre-asymptotic error estimates for finite element discretizations of the standard Helmholtz problem

$$\begin{cases} -\frac{\omega^2}{\mathcal{V}^2}u - \Delta u = f & \text{in } \Omega, \\ \nabla u \cdot \mathbf{n} - \frac{i\omega}{\mathcal{V}}u = 0 & \text{on } \Gamma_{\text{Diss}}, \\ u = 0 & \text{on } \Gamma_{\text{Dir}}. \end{cases}$$

In this case a uniform H^2 estimate (in ω) is needed and is formulated as an assumption in [8, Lemma 4.3]. This proof technique has been subsequently employed in later works [3, 5, 17, 18], but without a rigorous proof for the aforementioned estimate.

As a result, one of our motivations is to show that indeed such a uniform estimate is valid under realistic geometrical assumptions and for space dependent parameters \mathcal{V} . In this case, the (real-valued) function \mathcal{V} corresponds to the wavespeed in the domain. For the sake of simplicity, we focus on the case where $\mathcal{V} \in C^1(\overline{\Omega})$. Such a model is employed in [15] for instance.

In most applications related to Helmholtz equation, the boundary Γ_{Dir} is imposed, and represents an obstacle or the basis of a cavity. On the other hand, the boundary Γ_{Diss} is artificially designed to approximate the Sommerfeld condition. For complete electrode models, Γ_{Dir} is empty and ξ is different from zero on the electrodes.

We finish this section with some notations used in the remainder of the paper. For a bounded domain D , the usual norm and semi-norm of $H^s(D)$ ($s \geq 0$) are denoted by $\|\cdot\|_{s,D}$ and $|\cdot|_{s,D}$, respectively. Furthermore, the notation $A \lesssim B$ (resp. $A \gtrsim B$) means the existence of a positive constant C_1 (resp. C_2), which is independent of A , B and ξ (but might depend on Ω , c_b and c_\sharp), such that $A \leq C_1 B$ (resp. $A \geq C_2 B$). The notation $A \sim B$ means that $A \lesssim B$ and $A \gtrsim B$ hold simultaneously.

2. THE WEAK FORMULATION

Classically, assuming that $f \in L^2(\Omega)$, we recast (1.1) into the variational problem that consists in looking for $u \in H_{\Gamma_{\text{Dir}}}^1(\Omega)$ solution to

$$(2.1) \quad B(u, v) = (f, v), \quad \forall v \in H_{\Gamma_{\text{Dir}}}^1(\Omega),$$

where

$$B(u, v) = \langle \xi u, v \rangle_{\Gamma_{\text{Diss}}} + (A \nabla u, \nabla v),$$

and

$$H_{\Gamma_{\text{Dir}}}^1(\Omega) = \{v \in H^1(\Omega) : \gamma_0 v = 0 \text{ on } \Gamma_{\text{Dir}}\},$$

γ_0 being the trace operator from $H^1(\Omega)$ to $H^{\frac{1}{2}}(\partial\Omega)$.

Under the previous assumption, the sesquilinear form B is coercive on $H_{\Gamma_{\text{Dir}}}^1(\Omega)$ in the sense that

$$(2.2) \quad |B(v, v)| \gtrsim \|v\|_{1,\Omega}^2 + \|\xi^{\frac{1}{2}} v\|_{\Gamma_{\text{Diss}}}^2, \forall v \in H_{\Gamma_{\text{Dir}}}^1(\Omega).$$

Indeed writing $\xi = \sigma + i\omega$, for $v \in H_{\Gamma_{\text{Dir}}}^1(\Omega)$, due to (1.2) and (1.3), we have

$$|B(v, v)|^2 = \left(\int_{\Omega} A \nabla v \cdot \nabla v \, dx + \|\sigma^{\frac{1}{2}} v\|_{\Gamma_{\text{Diss}}}^2 \right)^2 + \|\omega^{\frac{1}{2}} v\|_{\Gamma_{\text{Diss}}}^4.$$

We then deduce that

$$\begin{aligned} |B(v, v)|^2 &\geq \left(\int_{\Omega} A \nabla v \cdot \nabla v \, dx \right)^2 + \|\sigma^{\frac{1}{2}} v\|_{\Gamma_{\text{Diss}}}^4 + \|\omega^{\frac{1}{2}} v\|_{\Gamma_{\text{Diss}}}^4 \\ &\gtrsim \left(\int_{\Omega} A \nabla v \cdot \nabla v \, dx \right)^2 + \|\xi^{\frac{1}{2}} v\|_{\Gamma_{\text{Diss}}}^4 \\ &\gtrsim |v|_{1,\Omega}^4 + \|\xi^{\frac{1}{2}} v\|_{\Gamma_{\text{Diss}}}^4. \end{aligned}$$

Since we have supposed that $|\xi| \geq c_b$ and that Γ_{Diss} is non-empty, we conclude that (2.2) holds with the following Poincaré inequality (see for instance Theorem 3.3 of [1] with $\varphi(v) = (1/|\Gamma_{\text{Diss}}|) \int_{\Gamma_{\text{Diss}}} v(x) \, d\sigma(x)$, for all $v \in H^1(\Omega)$, see also [13, Theorem 1]):

$$\|v\|_{0,\Omega} \lesssim |v|_{1,\Omega} + \|v\|_{\Gamma_{\text{Diss}}}.$$

Consequently by a variant of Lax-Milgram lemma (see [2, Theorem 2.1]), problem (2.1) has a unique solution $u \in H_{\Gamma_{\text{Dir}}}^1(\Omega)$ that satisfies

$$(2.3) \quad \|u\|_{1,\Omega} + \|\xi^{1/2} u\|_{\Gamma_{\text{Diss}}} \lesssim \|f\|.$$

The aim of our work is to find sufficient conditions that guarantee the H^2 regularity of the solution $u \in H_{\Gamma_{\text{Dir}}}^1(\Omega)$ of (2.1) with

$$(2.4) \quad \|u\|_{2,\Omega} \lesssim \|f\|.$$

where we recall that here and below the constant is independent of ξ for $|\xi|$ large enough.

We finally mention that deriving (2.4) is not trivial, as the standard “bootstrap” argument fails. Looking at the boundary condition on Γ_{Diss} as a non-homogeneous Neumann boundary condition

$$A \nabla u \cdot \mathbf{n} = -\xi u \text{ on } \Gamma_{\text{Diss}},$$

standard shift theorem yields the $H^2(\Omega)$ regularity of u , under some regularity assumptions on Γ_{Diss} and Γ_{Dir} since ξu belongs to $H^{1/2}(\Gamma_{\text{Diss}})$. With such an approach we obtain the estimate

$$\|u\|_{2,\Omega} \lesssim \|f\| + \|\xi u\|_{\frac{1}{2},\Gamma_{\text{Diss}}},$$

and using (2.3) we conclude that

$$\|u\|_{2,\Omega} \lesssim (1 + \max_{\Gamma_{\text{Diss}}} |\xi|^{\frac{1}{2}}) \|f\|.$$

As a result, we obtain an estimate like (2.4) but with a constant depending on ξ .

3. THE CONVEX CASE

In this section we focus on the case of convex domains. Here, we make the additional assumptions that $\Gamma_{\text{Dir}} = \emptyset$, that A is a constant matrix and that ξ is constant. Though these hypothesis seem rather restrictive, we will employ a localization argument in Section 5, and show that they are only required in in some neighborhood of the non-smooth parts of Γ_{Diss} (e.g. edges and corners). We start by making the assumption that $A = I_n$ is the identity matrix. We will get back to the general case by a change of coordinates argument. In the remaining of this section, we employ the notation $\xi = \sigma + i\omega$, with $\sigma, \omega \in \mathbb{R}$ for the (unique) value taken by the function ξ .

Theorem 3.1. *Assume that Ω is a convex domain with a C^2 boundary, that $A = I_n$ that $\Gamma_{\text{Dir}} = \emptyset$ and that ξ is constant. Then the solution $u \in H_{\Gamma_{\text{Dir}}}^1(\Omega)$ to (2.1) belongs to $H^2(\Omega)$ and satisfies (2.4), more precisely*

$$(3.1) \quad |u|_{2,\Omega} \leq \|f\|.$$

Proof. $u \in H^1(\Omega)$ can be seen as the solution of the inhomogeneous Neumann problem

$$\begin{cases} -\Delta u = f & \text{in } \Omega, \\ \nabla u \cdot \mathbf{n} = -\xi u & \text{on } \Gamma, \end{cases}$$

where Γ is the boundary of Ω . Then, by Theorem 2.4.2.7 of [9], u belongs to $H^2(\Omega)$ and hence ∇u belongs to $H^1(\Omega)^n$. Consequently we can apply Theorem 3.1.1.1 of [9] to the real (resp. imaginary) part \mathbf{V} (resp. \mathbf{W}) of ∇u (in other words, writing $u = X + iY$, with X and Y real-valued, we have $\mathbf{V} = \nabla X$ and $\mathbf{W} = \nabla Y$) to get

$$\begin{aligned} \int_{\Omega} (|\Delta X|^2 + |\Delta Y|^2) dx - (|X|_{2,\Omega}^2 + |Y|_{2,\Omega}^2) &= -2 \int_{\Gamma} (\mathbf{V}_T \cdot \nabla_T V_n + \mathbf{W}_T \cdot \nabla_T W_n) d\sigma \\ &\quad - \int_{\Gamma} \mathcal{B}(\mathbf{V}_T; \mathbf{V}_T) + \mathcal{B}(\mathbf{W}_T; \mathbf{W}_T) + (\text{tr } \mathcal{B})(V_n^2 + W_n^2) d\sigma, \end{aligned}$$

where \mathcal{B} is the second fundamental quadratic form of Γ and $\text{tr } \mathcal{B}$ is its trace (see [9, p. 133-134] for more details). $V_n = \mathbf{V} \cdot \mathbf{n}$ is the normal component of \mathbf{V} , $\mathbf{V}_T = \mathbf{V} - (V_n) \mathbf{n}$ is its tangential component and similar notations hold for \mathbf{W} . Due to the convexity of Ω , \mathcal{B} is non positive (see [9, p. 141]), and therefore the second term of this right-hand side is non negative. Therefore the previous identity implies that

$$\int_{\Omega} (|\Delta X|^2 + |\Delta Y|^2) dx - (|X|_{2,\Omega}^2 + |Y|_{2,\Omega}^2) \geq -2 \int_{\Gamma} (\mathbf{V}_T \cdot \nabla_T V_n + \mathbf{W}_T \cdot \nabla_T W_n) d\sigma.$$

But recalling that $\xi = \sigma + i\omega$, the boundary condition is equivalent to

$$V_n = -\sigma X + \omega Y, \quad W_n = -\omega X - \sigma Y \text{ on } \Gamma,$$

and thus, we have

$$\nabla_T V_n = -\sigma \nabla_T X + \omega \nabla_T Y, \quad \nabla_T W_n = -\omega \nabla_T X - \sigma \nabla_T Y.$$

Recalling that $\mathbf{V}_T = \nabla_T X$ and $\mathbf{W}_T = \nabla_T Y$, we may write

$$\begin{aligned} \int_{\Gamma} (\mathbf{V}_T \cdot \nabla_T V_n + \mathbf{W}_T \cdot \nabla_T W_n) d\sigma &= \int_{\Gamma} \omega (\nabla_T X \cdot \nabla_T Y - \nabla_T Y \cdot \nabla_T X) d\sigma \\ &\quad - \int_{\Gamma} \sigma (|\nabla_T X|^2 + |\nabla_T Y|^2) d\sigma \\ &= - \int_{\Gamma} \sigma (|\nabla_T X|^2 + |\nabla_T Y|^2) d\sigma \\ &\leq 0. \end{aligned}$$

This shows that

$$\int_{\Omega} (|\Delta X|^2 + |\Delta Y|^2) dx - (|X|_{2,\Omega}^2 + |Y|_{2,\Omega}^2) \geq 0,$$

and proves (3.1). \square

In Theorem 3.1 we established (2.4) for smooth convex domains with an explicit constant that is independent of the domain. In Theorem 3.2, we extend this result to general convex domains. Following [9], the key idea is to regularize the boundary of the domain and employ the uniform estimate of Theorem 3.1.

Theorem 3.2. *Assume that Ω is a convex domain, that $A = I_n$, that $\Gamma_{\text{Dir}} = \emptyset$ and that ξ is constant. Then the solution $u \in H_{\Gamma_{\text{Dir}}}^1(\Omega)$ to (2.1) belongs to $H^2(\Omega)$ and satisfies (2.4).*

Proof. As in [9, p. 157], we approach Ω by a sequence of bounded and convex domains $\Omega_m, m \in \mathbb{N}$, with a C^2 boundary such that $\Omega \subset \Omega_m$ for all $m \in \mathbb{N}$, and $d(\Gamma_m, \Gamma) \rightarrow 0$ as $m \rightarrow \infty$, where Γ_m is the boundary of Ω_m .

Then for all $m \in \mathbb{N}$, we consider $u_m \in H^2(\Omega_m)$ solution to

$$(3.2) \quad \begin{cases} -\Delta u_m = \tilde{f} & \text{in } \Omega_m, \\ \nabla u_m \cdot \mathbf{n} + \xi u_m = 0 & \text{on } \Gamma_m, \end{cases}$$

where \tilde{f} is the extension of f by zero outside Ω . Theorem 3.1 yields

$$(3.3) \quad |u_m|_{2,\Omega_m} \leq \|\tilde{f}\|_{\Omega_m} = \|f\|.$$

We first check that

$$(3.4) \quad \|v\|_{1,\Omega_m}^2 \lesssim |v|_{1,\Omega_m}^2 + \int_{\Gamma_m} |v|^2 d\sigma \quad \forall v \in H^1(\Omega_m),$$

where here and below in the proof, the constant is independent of ξ but also of m . For that purpose, using Lemma 3.2.3.2 of [9] and its notation, in local coordinates (z^k, y_n^k) in the hypercube $V_k = V'_k \times (-a_n^k, a_n^k)$, $k = 1, \dots, K$ (common to all Ω_m), we may write

$$v(z^k, y_n^k) = v(z^k, \varphi_m^k(z^k)) + \int_{\varphi_m^k(z^k)}^{y_n^k} \partial_n v(z^k, s) ds,$$

for any $v \in C^\infty(\bar{\Omega}_m)$. Note that, here and below, $\partial_n = \frac{\partial}{\partial y_n^k}$ is the partial derivative with respect to y_n^k , the dependency on k is omitted for shortness. Taking the square of this identity and using Cauchy-Schwarz's inequality, we get

$$|v(z^k, y_n^k)|^2 \lesssim |v(z^k, \varphi_m^k(z^k))|^2 + \int_{-a_n^k}^{\varphi_m^k(z^k)} |\partial_n v(z^k, s)|^2 ds.$$

Integrating this result in $y_n^k \in (-a_n^k, \varphi_m^k(z^k))$ and in $z^k \in V'_k$, one gets

$$\|v\|_{0, \Omega_m \cap V_k}^2 \lesssim \|v\|_{0, \Gamma_m \cap V_k}^2 + |v|_{1, \Omega_m \cap V_k}^2,$$

where the hidden constant is independent of m . Summing up this estimate on k , and using a density argument, we arrive at

$$(3.5) \quad \|v\|_{0, O_m} \lesssim \|v\|_{0, \Gamma_m} + |v|_{1, \Omega_m} \quad \forall v \in H^1(\Omega_m),$$

where O_m is a neighborhood of Γ_m defined by $O_m = \cup_{k=1}^K (\Omega_m \cap V_k)$. Hence defining $O = \cup_{k=1}^K (\Omega \cap V_k)$, we deduce that $O \subset O_m$.

By the compact embedding of $H^1(\Omega)$ into $L^2(\Omega)$ and the use of a contradiction argument, one easily shows that

$$\|w\|_{0, \Omega} \lesssim \|w\|_{0, O} + |w|_{1, \Omega} \quad \forall w \in H^1(\Omega).$$

Since any element $v \in H^1(\Omega_m)$ can be seen as an element of $H^1(\Omega)$, applying this estimate to v and (3.5) and the fact that $O \subset O_m$ to estimate this right-hand side, we deduce that

$$(3.6) \quad \|v\|_{0, \Omega} \lesssim \|v\|_{0, \Gamma_m} + |v|_{1, \Omega_m} \quad \forall v \in H^1(\Omega_m).$$

As for $v \in H^1(\Omega_m)$, we clearly have

$$\|v\|_{0, \Omega_m} \leq \|v\|_{0, \Omega} + \|v\|_{0, O_m},$$

by (3.5) and (3.6), we conclude that

$$\|v\|_{0, \Omega_m} \lesssim \|v\|_{0, \Gamma_m} + |v|_{1, \Omega_m},$$

and consequently (3.4) holds.

If we come back to (3.2), using its variational formulation, (3.3) and (3.4) one gets

$$(3.7) \quad \|u_m\|_{2, \Omega_m} \lesssim \|f\|_{0, \Omega} \quad \forall m \in \mathbb{N}.$$

Again as $\Omega \subset \Omega_m$, this estimate implies in particular that

$$\|u_m\|_{2, \Omega} \lesssim \|f\|_{0, \Omega} \quad \forall m \in \mathbb{N}.$$

Hence owing to the compact embedding of $H^2(\Omega)$ into $H^s(\Omega)$, for all $s < 2$, we deduce that there exists $u \in H^2(\Omega)$ such that, up to a subsequence still denoted by $(u_m)_m$ for shortness, we have

$$(3.8) \quad u_m \rightharpoonup u \text{ weakly in } H^2(\Omega), \text{ as } m \rightarrow \infty,$$

$$(3.9) \quad u_m \rightarrow u \text{ strongly in } H^s(\Omega), \text{ as } m \rightarrow \infty, \forall s < 2,$$

and

$$(3.10) \quad \|u\|_{2, \Omega} \lesssim \|f\|_{0, \Omega}.$$

It remains to show that u is the unique solution to (2.1). For that purpose, we fix an arbitrary element $v \in C^\infty(\bar{\Omega})$. As Ω has a Lipschitz boundary (see [9, Corollary 1.2.3.3]), there exists an extension operator E from $H^1(\Omega)$ into $H^1(\mathbb{R}^n)$ that is a linear, continuous and such that $Ev = v$ in Ω . Furthermore by [9, p. 23], Ev belongs to $H^k(\mathbb{R}^n)$, for all $k \in \mathbb{N}$, hence in particular it is C^1 .

Let us first show that

$$(3.11) \quad \int_{\Omega_m} \nabla u_m \cdot \nabla(Ev) \, dx \rightarrow \int_{\Omega} \nabla u \cdot \nabla v \, dx,$$

as $m \rightarrow \infty$. We may write

$$\begin{aligned} \left| \int_{\Omega_m} \nabla u_m \cdot \nabla(Ev) \, dx - \int_{\Omega} \nabla u \cdot \nabla v \, dx \right| &= \left| \int_{\Omega} \nabla(u_m - u) \cdot \nabla v \, dx + \int_{\Omega_m \setminus \Omega} \nabla u_m \cdot \nabla(Ev) \, dx \right| \\ &\leq \|u_m - u\|_{1,\Omega} \|v\|_{1,\Omega} + |u_m|_{1,\Omega_m} |Ev|_{1,\Omega_m \setminus \Omega}. \end{aligned}$$

By (3.9), the first term of this right-hand side tends to zero as m goes to infinity, while by (3.7), we have

$$|u_m|_{1,\Omega_m} |Ev|_{1,\Omega_m \setminus \Omega} \lesssim \|f\|_{0,\Omega} |Ev|_{1,\Omega_m \setminus \Omega}.$$

As the measure of $\Omega_m \setminus \Omega$ tends to zero and $Ev \in C^1$, this right-hand side tends to zero as m goes to infinity, which leads to (3.11).

Let us secondly show that

$$(3.12) \quad \int_{\Gamma_m} u_m Ev \, d\sigma_m \rightarrow \int_{\Gamma} uv \, d\sigma,$$

as $m \rightarrow \infty$. We can fix cut-off functions $\theta_k \in \mathcal{D}(\mathbb{R}^n)$, $k = 1, \dots, K$ such that the support of θ_k is included into V_k and

$$\sum_{k=1}^K \theta_k = 1 \text{ on } \Gamma \cup \Gamma_m,$$

for m large enough, see [9, p. 162]. Consequently, for m large enough, we may write

$$(3.13) \quad \begin{aligned} \int_{\Gamma_m} u_m Ev \, d\sigma_m &= \sum_{k=1}^K \int_{\Gamma_m} u_m \theta_k Ev \, d\sigma_m \\ &= \sum_{k=1}^K \int_{V'_k} u_m(z, \varphi_m^k(z)) Ev(z, \varphi_m^k(z)) \theta_k(z, \varphi_m^k(z)) \sqrt{1 + |\nabla \varphi_m^k(z)|^2} \, dz. \end{aligned}$$

As u_m belongs to $H^2(\Omega_m)$, it is continuous in $\bar{\Omega}_m$, and we may write

$$u_m(z, \varphi_m^k(z)) - u_m(z, \varphi^k(z)) = \int_{\varphi^k(z)}^{\varphi_m^k(z)} \partial_n u_m(z, s) \, ds,$$

which yields the splitting

$$u_m(z, \varphi_m^k(z)) = u(z, \varphi^k(z)) + r_{m,1}(z) + r_{m,2}(z),$$

where the remainders are defined by

$$\begin{aligned} r_{m,1}(z) &= u_m(z, \varphi^k(z)) - u(z, \varphi^k(z)), \\ r_{m,2}(z) &= \int_{\varphi^k(z)}^{\varphi_m^k(z)} \partial_n u_m(z, s) ds. \end{aligned}$$

Similarly we can split up $Ev(z, \varphi_m^k(z))$ into

$$Ev(z, \varphi_m^k(z)) = v(z, \varphi^k(z)) + s_m(z),$$

where

$$s_m(z) = \int_{\varphi^k(z)}^{\varphi_m^k(z)} \partial_n Ev(z, s) ds.$$

All together we can split up

$$\begin{aligned} u_m(z, \varphi_m^k(z))Ev(z, \varphi_m^k(z)) &= u(z, \varphi^k(z))v(z, \varphi^k(z)) + u(z, \varphi^k(z))s_m(z) \\ &+ r_{m,1}(z)v(z, \varphi^k(z)) + r_{m,1}(z)s_m(z) \\ &+ r_{m,2}(z)v(z, \varphi^k(z)) + r_{m,2}(z)s_m(z), \\ &= X + R_{m,1} + R_{m,2} + R_{m,3}, \end{aligned}$$

where

$$\begin{aligned} X &= u(z, \varphi^k(z))v(z, \varphi^k(z)) \\ R_{m,1} &= u(z, \varphi^k(z))s_m(z) \\ R_{m,2} &= r_{m,1}(z)[v(z, \varphi^k(z)) + s_m(z)] \\ R_{m,3} &= r_{m,2}(z)[v(z, \varphi^k(z)) + s_m(z)], \end{aligned}$$

These terms are now analyzed separately.

1. For X , as

$$X\theta_k(z, \varphi_m^k(z))\sqrt{1 + |\nabla\varphi_m^k(z)|^2} \rightarrow X\theta_k(z, \varphi^k(z))\sqrt{1 + |\nabla\varphi^k(z)|^2} \text{ a.e. in } V'_k,$$

$\theta_k(z, \varphi_m^k(z))\sqrt{1 + |\nabla\varphi_m^k(z)|^2}$ is uniformly bounded (in z and in m) and uv is integrable in Γ , by Lebesgue's convergence theorem we deduce that

$$\begin{aligned} (3.14) \quad &\int_{V'_k} u(z, \varphi^k(z))v(z, \varphi^k(z))\theta_k(z, \varphi_m^k(z))\sqrt{1 + |\nabla\varphi_m^k(z)|^2} dz \\ &\rightarrow \int_{V'_k} u(z, \varphi^k(z))v(z, \varphi^k(z))\theta_k(z, \varphi^k(z))\sqrt{1 + |\nabla\varphi^k(z)|^2} dz \end{aligned}$$

as $m \rightarrow \infty$.

2. The first reminder $R_{m,1}$ is managed as follows, recalling that θ_k is bounded and that

$|\nabla\varphi_m^k(z)|$ is uniformly bounded:

$$\begin{aligned} I_{m,1} &:= \left| \int_{V'_k} R_{m,1}\theta_k(z, \varphi_m^k(z))\sqrt{1 + |\nabla\varphi_m^k(z)|^2} dz \right| \\ &\lesssim \left| \int_{V'_k} |u(z, \varphi^k(z))| |s_m(z)| dz \right| \lesssim \|u\|_{\infty, \Omega} \|s_m\|_{V'_k}. \end{aligned}$$

This leads to

$$(3.15) \quad I_{m,1} \rightarrow 0$$

as $m \rightarrow \infty$, if we can prove that

$$(3.16) \quad \|s_m\|_{V'_k} \rightarrow 0,$$

as $m \rightarrow \infty$. But, by Cauchy-Schwarz's inequality we have

$$\begin{aligned} \|s_m\|_{V'_k}^2 &\leq \int_{V'_k} |\varphi^k(z) - \varphi_m^k(z)|^2 \left(\int_{\varphi^k(z)}^{\varphi_m^k(z)} |\partial_n Ev(z, s)|^2 ds \right) dz \\ &\leq \|\varphi^k - \varphi_m^k\|_{\infty, V'_k} |Ev|_{1, V_k \cap \Omega_m}^2 \\ &\lesssim \|\varphi^k - \varphi_m^k\|_{\infty, V'_k} \|v\|_{1, \Omega}^2. \end{aligned}$$

This leads to (3.16) as φ_m^k converges uniformly to φ^k in V'_k (see again Lemma 3.2.3.2 of [9]).

3. The second reminder is easily estimated by

$$I_{m,2} := \left| \int_{V'_k} R_{m,2}\theta_k(z, \varphi_m^k(z))\sqrt{1 + |\nabla\varphi_m^k(z)|^2} dz \right| \lesssim \|u_m - u\|_{\infty, \Omega} (\|s_m\|_{0, V'_k} + \|v\|_{0, \Gamma}),$$

and we conclude that

$$(3.17) \quad I_{m,2} \rightarrow 0$$

as $m \rightarrow \infty$, owing to (3.9) and the Sobolev embedding theorem.

4. For the last reminder, we notice as before that

$$\|r_{m,2}\|_{V'_k}^2 \leq \|\varphi^k - \varphi_m^k\|_{\infty, V'_k} |u_m|_{1, V_k \cap \Omega_m}^2$$

and by (3.7) and (3.9) we deduce that

$$(3.18) \quad \|r_{m,2}\|_{V'_k} \rightarrow 0$$

as $m \rightarrow \infty$. Consequently by Cauchy-Schwarz's inequality one obtain

$$\begin{aligned} I_{m,3} &:= \left| \int_{V'_k} r_{m,2}(z)(v(z, \varphi^k(z)) + s_m(z))\theta_k(z, \varphi_m^k(z))\sqrt{1 + |\nabla\varphi_m^k(z)|^2} dz \right| \\ &\lesssim \|r_{m,2}\|_{V'_k} (\|v\|_{\Gamma} + \|s_m\|_{V'_k}), \end{aligned}$$

and (3.18) and (3.16) lead to

$$(3.19) \quad I_{m,3} \rightarrow 0$$

as $m \rightarrow \infty$.

In summary using the properties (3.14) to (3.19) into the identity (3.13), we arrive at

$$\int_{\Gamma_m} u_m Ev d\sigma_m \rightarrow \sum_{k=1}^K \int_{V'_k} u(z, \varphi^k(z)) v(z, \varphi_m^k(z)) \theta_k(z, \varphi^k(z)) \sqrt{1 + |\nabla \varphi^k(z)|^2} dz,$$

which is exactly (3.12).

In conclusion, starting from the variational formulation of (3.2) with the test-function Ev :

$$\int_{\Omega_m} \nabla u \cdot \nabla (Ev) dx + \xi \int_{\Gamma_m} u_m Ev d\sigma_m = \int_{\Omega} f v dx,$$

passing to the limit in m and using (3.11)-(3.12), one obtains

$$\int_{\Omega} \nabla u \cdot \nabla v dx + \xi \int_{\Gamma} uv d\sigma = \int_{\Omega} f v dx.$$

Since this holds for all $v \in C^\infty(\bar{\Omega})$, by density this identity remains valid for all $v \in H^1(\Omega)$ and consequently u is the unique solution of (2.1). The estimate (3.10) ends the proof. \square

Corollary 3.3. *Assume that Ω is convex, that $\Gamma_{\text{Dir}} = \emptyset$ and that A and ξ are constant. Then the solution $u \in H_{\Gamma_{\text{Dir}}}^1(\Omega)$ to (2.1) belongs to $H^2(\Omega)$ and satisfies (2.4).*

Proof. Let us consider a matrix $T \in \mathbb{R}^{n \times n}$ such that

$$T^\top AT = I_n,$$

then by the change of variables $\hat{x} = T^\top x$, and the change of unknown $\hat{u}(\hat{x}) = u(x)$, we transform problem (2.1) into a similar one in $\hat{\Omega}$ with $A = I_n$ and $\widehat{\Gamma_{\text{Dir}}} = \emptyset$. Since a linear mapping preserves the convexity, $\hat{\Omega}$ is convex. Hence we conclude by applying Theorem 3.2 to \hat{u} and using the transformation back. \square

4. THE SMOOTH CASE

In this section we show that Theorem 3.1 remains valid if the convexity assumption is replaced by the assumption that the boundary is of class $C^{1,1}$, but with no control of the constant in (3.1). Our proof is based on an adaptation of the so-called method of tangential differential quotients of Nirenberg (see [9] for instance). Let us start with two technical results, namely local H^2 -regularity results: the first one concerns the case when Γ_{Diss} is flat. Let $U = V \cap \mathbb{R}_+^n$, where V is open domain of \mathbb{R}^n . To simplify notation, we set

$$H_c^1(U) = \{u \in H^1(U) \mid \exists W \text{ a neighborhood of } \partial V \setminus \{x_n = 0\} \text{ such that } u = 0 \text{ in } W\},$$

$$H_+^1(U) = \{u \in H^1(U) \mid \text{such that } u = 0 \text{ on } \partial V \setminus \{x_n = 0\}\},$$

$$\Gamma_U = \partial V \cap \{x_n = 0\}.$$

Lemma 4.1. *Assume that $u \in H_c^1(U)$ satisfies*

$$\begin{cases} -\nabla \cdot (A\nabla u) = f & \text{in } U, \\ A\nabla u \cdot \mathbf{n} + \xi du = 0 & \text{on } \Gamma_U, \end{cases}$$

where $A \in C^{0,1}(\bar{U}; \mathbb{R}^{n \times n})$ is uniformly positive definite in \bar{U} , $d \in C^1(\Gamma_U; \mathbb{R})$ is a strictly positive function and $f \in L^2(U)$. Then u belongs to $H^2(U)$ and satisfies

$$\|u\|_{2,U} \lesssim \|f\|_U + \|u\|_{1,U} + \|\xi|^{1/2}u\|_{\Gamma_U}.$$

Proof. Let us first notice that the regularity $u \in H^2(U)$ follows immediately from standard shift property since ξdu belongs to $H^{\frac{1}{2}}(\Gamma_U)$. Now, we introduce the ‘‘differential quotients’’ that we employ in the proof. Let $(e_j)_{j=1}^n$ denote the canonical basis of \mathbb{R}^n . For $h \in \mathbb{R}^*$ and $i \in \{1, \dots, n-1\}$ we introduce the translation operator $\tau_{j,h}$ defined by $(\tau_{j,h}\phi)(x) = \phi(x + he_j)$ for a scalar or vectorial function ϕ . In addition, we define the differential quotient $D_{j,h}$ as

$$D_{j,h}\phi = \frac{1}{|h|} (\tau_{j,h}\phi - \phi).$$

The key properties of $D_{j,h}$ can be found, for instance, in [4, Section 9.6].

Since $u \in H_c^1(U)$, we see that if $|h|$ is small enough, $\tau_{j,h}u \in H_c^1(U)$, and therefore, the function $v = D_{j,-h}D_{j,h}u \in H_0^1(U)$.

We recall that the variational formulation of (4.1) is

$$\int_U A\nabla u \cdot \nabla \bar{w} dx + \int_{\Gamma_U} \xi du \bar{w} d\sigma = \int_U f \bar{w} \quad \forall w \in H_+^1(U).$$

We select $w = v$ as a test function. Noticing that the adjoint operator of $D_{j,h}$ is $D_{j,-h}$, we obtain

$$(4.1) \quad \int_U D_{j,h}(A\nabla u) \cdot \nabla D_{j,h}\bar{u} dx + \int_{\Gamma_U} D_{j,h}(\xi du) \overline{D_{j,h}u} d\sigma = \int_U f D_{j,-h}D_{j,h}\bar{u} dx.$$

Since for two functions ψ and ϕ , the discrete Leibniz rule $D_{j,h}(\psi\phi) = (D_{j,h}\psi)(\tau_{j,h}\phi) + \psi(D_{j,h}\phi)$ holds, we get

$$\begin{aligned} \int_U D_{j,h}(A\nabla u) \cdot \nabla D_{j,h}\bar{u} dx &= \int_U ((D_{j,h}A)(\tau_{j,h}\nabla u)) \cdot \nabla D_{j,h}\bar{u} dx + \int_U |A^{\frac{1}{2}}\nabla D_{j,h}u|^2 dx, \\ \int_{\Gamma_U} D_{j,h}(\xi du) \overline{D_{j,h}u} d\sigma &= \int_{\Gamma_U} D_{j,h}(\xi d)(\tau_{j,h}u) \overline{D_{j,h}u} d\sigma + \int_{\Gamma_U} \xi d |D_{j,h}u|^2 d\sigma. \end{aligned}$$

Therefore the previous identity may be transformed into

$$(4.2) \quad \int_U |A^{\frac{1}{2}}\nabla(D_{j,h}u)|^2 dx + \int_{\Gamma_U} \xi d |D_{j,h}u|^2 d\sigma = \int_U f D_{j,-h}D_{j,h}\bar{u} dx - \int_U ((D_{j,h}A)(\tau_{j,h}\nabla u)) \cdot \nabla D_{j,h}\bar{u} dx - \int_{\Gamma_U} D_{j,h}(\xi d)(\tau_{j,h}u) \overline{D_{j,h}u} d\sigma.$$

Lemma 2.2.2.2 of [9] shows that $\|D_{j,h}\phi\|_U \leq \|D_j\phi\|_U$ for all $\phi \in H_c^1(U)$, where here and afterward, we use the notation

$$D_j = \frac{\partial}{\partial \mathbf{x}_j},$$

therefore, up to a subsequence $D_{j,h}\phi$ converges strongly to $D_j\phi$ in $L^2(U)$. Since we already know that u belongs to $H^2(U)$, this argument yields that $D_{j,h}u$ converges strongly to D_ju in $L^2(U)$, and that $D_{j,h}\nabla u$ converges strongly to $D_j\nabla u$ in $L^2(U)^n$ (up to a subsequence). Hence, in the identity (4.2), taking the limit when h tends to 0 (up to a subsequence), we have

$$(4.3) \quad \int_U |A^{\frac{1}{2}}\nabla D_ju|^2 dx + \int_{\Gamma_U} \xi d|D_ju|^2 d\sigma = \int_U f D_j^2 \bar{u} dx \\ - \int_U (D_j A)\nabla u \cdot \nabla D_j \bar{u} dx - \int_{\Gamma_U} D_j(\xi d)u \overline{D_j u} d\sigma.$$

Thus, taking the real part of (4.3), we have

$$(4.4) \quad \int_U |A^{\frac{1}{2}}\nabla D_ju|^2 dx + \int_{\Gamma_U} \sigma d|D_ju|^2 d\sigma \lesssim \|f\|_U \|D_j^2 u\|_U + \|D_j A \nabla u\|_U \|D_j \nabla u\|_U \\ + \operatorname{Re} \left(\int_{\Gamma_U} (\xi D_j d + d D_j \xi) u \overline{D_j u} d\sigma \right) \\ \lesssim (\|f\|_U + \|u\|_{1,U}) \|\nabla D_j u\|_U + \|\xi^{1/2} u\|_{\Gamma_U} \|\xi^{1/2} D_j u\|_{\Gamma_U} \\ + \operatorname{Re} \left(\int_{\Gamma_U} d \frac{D_j(\xi)}{\xi} \xi u \overline{D_j u} d\sigma \right) \\ \lesssim (\|f\|_U + \|u\|_{1,U}) \|\nabla D_j u\|_U + \|\xi^{1/2} u\|_{\Gamma_U} \|\xi^{1/2} D_j u\|_{\Gamma_U},$$

where we have used (1.5). On the other hand, by taking the imaginary part of (4.3), in the same way as (4.4), we have

$$(4.5) \quad \omega \int_{\Gamma_U} d|D_ju|^2 d\sigma \lesssim (\|f\|_U + \|u\|_{1,U}) \|\nabla D_j u\|_U + \|\xi^{1/2} u\|_{\Gamma_U} \|\xi^{1/2} D_j u\|_{\Gamma_U}.$$

Recalling that A is positive definite, that $d \geq d_0 > 0$ and that $|\xi| \simeq \sigma + |\omega|$, it follows from (4.4) and (4.5) that

$$\|D_j \nabla u\|_U^2 + d_0 \|\xi^{1/2} D_j u\|_{\Gamma_U}^2 \lesssim \int_U |A^{\frac{1}{2}}\nabla D_ju|^2 dx + \int_{\Gamma_U} (\sigma + |\omega|) d|D_ju|^2 d\sigma \\ \lesssim \int_U |A^{\frac{1}{2}}\nabla D_ju|^2 dx + \int_{\Gamma_U} \sigma d|D_ju|^2 d\sigma + \left| \int_{\Gamma_U} \omega d|D_ju|^2 d\sigma \right| \\ \lesssim (\|f\|_U + \|u\|_{1,U}) \|\nabla D_j u\|_U + \|\xi^{1/2} u\|_{\Gamma_U} \|\xi^{1/2} D_j u\|_{\Gamma_U}.$$

By Young's inequality we deduce that for all $\epsilon > 0$,

$$\begin{aligned} \|D_j \nabla u\|_U^2 + d_0 \|\xi^{1/2} D_j u\|_{\Gamma_U}^2 &\leq C \left(\|f\|_U + \|u\|_{1,U} \right) \|\nabla D_j u\|_U \\ &\quad + \frac{C\epsilon}{2} \|\xi^{1/2} D_j u\|_{\Gamma_U}^2 + \frac{C}{2\epsilon} \|\xi^{1/2} u\|_{\Gamma_U}^2, \end{aligned}$$

for some $C > 0$ (independent of $\epsilon > 0$). Choosing $\epsilon > 0$ small enough so that $d_0 - \frac{C\epsilon}{2} \geq 0$, we have

$$\begin{aligned} \|D_j \nabla u\|_U^2 &\leq \|D_j \nabla u\|_U^2 + \left(d_0 - \frac{C\epsilon}{2}\right) \|\xi^{1/2} D_j u\|_{\Gamma_U}^2 \\ &\lesssim \left(\|f\|_U + \|u\|_{1,U} \right) \|\nabla D_j u\|_U + \|\xi^{1/2} u\|_{\Gamma_U}^2. \end{aligned}$$

Again by Young's inequality, we arrive at

$$\|D_j \nabla u\|_U \lesssim \|f\|_U + \|u\|_{1,U} + \|\xi^{1/2} u\|_{\Gamma_U},$$

which we may rewrite as

$$\left\| \frac{\partial^2 u}{\partial x_j \partial x_k} \right\|_U \lesssim \|f\|_U + \|u\|_{1,U} + \|\xi^{1/2} u\|_{\Gamma_U},$$

for $(j, k) \in \{1, \dots, n\}^2 \setminus \{(n, n)\}$. Thus, it remains to show that

$$\frac{\partial^2 u}{\partial x_n^2} \in L^2(U),$$

with a similar estimate. To do so, we observe that since $-\nabla \cdot (A \nabla u) = f$, we have

$$-\frac{\partial}{\partial x_n} \left(A_{nn} \frac{\partial u}{\partial x_n} \right) = f + \sum_{(j,k) \neq (n,n)} \frac{\partial}{\partial x_j} \left(A_{jk} \frac{\partial u}{\partial x_k} \right) \in L^2(U).$$

Indeed, the right-hand-side only contains already estimated derivatives of u . We conclude the proof since

$$\frac{\partial^2 u}{\partial x_n^2} = \frac{1}{A_{nn}} \left(\frac{\partial}{\partial x_n} \left(A_{nn} \frac{\partial u}{\partial x_n} \right) - \frac{\partial A_{nn}}{\partial x_n} \frac{\partial u}{\partial x_n} \right) \in L^2(\Omega).$$

□

In the next lemma, we employ a change of coordinates to analyze the case of a $C^{1,1}$ boundary Γ_{Diss} .

Corollary 4.2. *Let Ω be an open domain of \mathbb{R}^n with a $C^{1,1}$ boundary. For $x \in \partial\Omega$ and $R > 0$ small enough, we consider $V = \Omega \cap B(x, R)$ and $\Gamma_V = \partial\Omega \cap B(x, R)$ as well as the space*

$$H_c^1(V) = \{v \in H^1(V) \mid u = 0 \text{ on a neighborhood of } \partial V \setminus \Gamma_V\}.$$

Assume that $u \in H_c^1(V)$ satisfies

$$\begin{cases} -\nabla \cdot (A \nabla u) = f & \text{in } V, \\ A \nabla u \cdot \mathbf{n} + \xi u = 0 & \text{on } \Gamma_V, \end{cases}$$

where $A \in C^{0,1}(\bar{V}, \mathbb{R}^{n \times n})$ is symmetric positive definite, and $f \in L^2(\Omega)$. Then

$$\|u\|_{2,V} \lesssim \|f\|_V + \|u\|_{1,V} + \|\xi\|^{1/2} \|u\|_{\Gamma_V}.$$

Proof. For R small enough, there exists a $C^{1,1}$ diffeomorphism Φ from an open set V_2 of \mathbb{R}^n onto $B(x, R)$, such that

$$\Phi^{-1}(\Omega \cap \Phi(V_2)) = \Phi^{-1}(V) = U = \mathbb{R}_+^n \cap V_2.$$

Following [9, §2.2.2], $u^\# = u \circ \Phi^{-1}$ satisfies

$$\begin{cases} -\nabla \cdot (A^\# \nabla u^\#) = f^\# & \text{in } U, \\ A^\# \nabla u^\# \cdot \mathbf{n} + \xi^\# d^\# u^\# = 0 & \text{on } \Gamma_U, \end{cases}$$

with $d^\#$ a strictly positive $C^{1,1}$ function, $A^\#$ positive definite in \bar{U} , and $\xi^\# = \xi \circ \Phi^{-1}$. Hence, we can apply the previous lemma to this system and use a transformation back to conclude. \square

Theorem 4.3. *If Ω is a bounded domain with a $C^{1,1}$ boundary such that $\overline{\Gamma_{\text{Dir}}} \cap \overline{\Gamma_{\text{Diss}}} = \emptyset$, then the solution $u \in H_{\Gamma_{\text{Dir}}}^1(\Omega)$ of (2.1) belongs to $H^2(\Omega)$ and satisfies (2.4).*

Proof. We take an open covering of $\Omega = \cup_{1 \leq i \leq N} V_i$ with $V_i = B(x_i, R_i) \cap \Omega$ such that either $B(x_i, R_i) \subset \Omega$ or $x_i \in \partial\Omega$. We take a partition of unity $(\eta_i)_{1 \leq i \leq N}$ related to this covering, i. e., $\eta_i \in \mathcal{D}(V_i)$, for all $1 \leq i \leq N$ and $\sum_{i=1}^N \eta_i = 1$ on $\bar{\Omega}$. So, for all $1 \leq i \leq N$, we may write

$$\begin{aligned} B(u, \eta_i v) &= \int_{\Omega} A \nabla u \cdot \nabla (\eta_i \bar{v}) dx + \int_{\partial\Omega} \xi u \eta_i \bar{v} d\sigma \\ &= \int_{\Omega} A \nabla u \cdot ((\nabla \eta_i) \bar{v} + (\nabla \bar{v}) \eta_i) dx + \int_{\partial\Omega} \xi \eta_i u \bar{v} d\sigma \\ &= \int_{\Omega} A \nabla (\eta_i u) \cdot \nabla \bar{v} + (\nabla \eta_i \cdot A \nabla u) \bar{v} - u (A \nabla \eta_i \cdot \nabla \bar{v}) dx + \int_{\partial\Omega} \xi \eta_i u \bar{v} d\sigma. \end{aligned}$$

Moreover, Green's formula yields

$$\begin{aligned} \int_{\Omega} u (A \nabla \eta_i \cdot \nabla \bar{v}) dx &= - \int_{\Omega} \nabla \cdot (u A \nabla \eta_i) \bar{v} dx + \int_{\partial\Omega} A \nabla \eta_i \cdot \mathbf{n} u \bar{v} d\sigma \\ &= \int_{\Omega} \nabla \cdot (u A \nabla \eta_i) \bar{v} dx + \int_{\Gamma_{V_i}} (A \nabla \eta_i \cdot \mathbf{n}) u \bar{v} d\sigma, \end{aligned}$$

where we recall that $\Gamma_{V_i} = B(x_i, R_i) \cap \partial\Omega$. Hence, setting on Γ_{V_i} , $g = (A \nabla \eta_i \cdot \mathbf{n}) u$, we deduce that

$$B(\eta_i u, v) = \langle \eta_i f + \nabla \cdot (u A \nabla \eta_i) + \nabla \eta_i \cdot A \nabla u, v \rangle_{V_i} + \langle g, v \rangle_{\Gamma_{V_i}}.$$

Now, we remark that there exists $\tilde{u}_i \in H_c^1(V_i) \cap H^2(V_i)$ such that

$$(4.6) \quad \tilde{u}_i = 0, \quad A \nabla \tilde{u}_i \cdot \mathbf{n} = (A \nabla \eta_i \cdot \mathbf{n}) u \quad \text{on } \Gamma_{V_i},$$

with

$$(4.7) \quad \|\tilde{u}_i\|_{2,V_i} \lesssim \|u\|_{1,V_i}.$$

Indeed as $\frac{1}{n^\top An} \in C^{1,1}(\partial\Omega)$, this last problem is equivalent to

$$\tilde{u}_i = 0, \partial_n \tilde{u}_i = \frac{g}{n^\top An} \text{ on } \Gamma_{V_i}.$$

Now fix a larger domain \tilde{V}_i than V_i with a $C^{1,1}$ boundary that contains Γ_{V_i} . Furthermore let \tilde{g} be the extension of g by zero outside the support of g , Then Theorem 1.5.1.2 of [9] ensures the existence of a function $v_i \in H_0^1(\tilde{V}_i) \cap H^2(\tilde{V}_i)$ such that

$$A\nabla v_i \cdot n = \tilde{g} \quad \text{on } \partial\tilde{V}_i,$$

with

$$\|v_i\|_{2,\tilde{V}_i} \lesssim \left\| \frac{\tilde{g}}{n^\top An} \right\|_{\frac{1}{2},\partial\tilde{V}_i} \lesssim \|g\|_{\frac{1}{2},\Gamma_{V_i}} \lesssim \|u\|_{1,V_i}.$$

Then, we fix a cut-off function ψ_i such that $\psi_i = 1$ on the support of g and that is zero in a neighbourhood of $\partial V_i \setminus \Gamma_{V_i}$. We readily check that

$$\tilde{u}_i = \psi_i v_i,$$

satisfies the requested properties.

By Green's formula, we see that

$$\begin{aligned} \int_{V_i} A\nabla \tilde{u}_i \cdot \nabla \bar{v} dx &= \int_{V_i} -\nabla \cdot (A\nabla \tilde{u}_i) \bar{v} dx + \int_{\partial V_i} A\nabla \tilde{u}_i \cdot n \bar{v} d\sigma \\ &= \int_{V_i} -\nabla \cdot (A\nabla \tilde{u}_i) \bar{v} dx + \int_{\Gamma_{V_i}} g \bar{v} d\sigma. \end{aligned}$$

Then, by defining $u_i = \eta_i u - \tilde{u}_i$, we notice that $u_i \in H_+^1(V_i)$ verifies for all $v \in H^1(\Omega)$

$$\begin{aligned} B_{V_i}(u_i, v) &= B_{V_i}(\eta_i u, v) - B_{V_i}(\tilde{u}_i, v) \\ &= \langle \eta_i f, v \rangle_{V_i} + \langle \nabla \eta_i \nabla u, v \rangle_{V_i} + \langle \nabla \cdot (u \nabla \eta_i), v \rangle_{V_i} \\ &\quad + \int_{V_i} \nabla \cdot (A\nabla \tilde{u}_i) \bar{v} dx - \int_{\Gamma_{V_i}} g \bar{v} d\sigma + \int_{\Gamma_{V_i}} g \bar{v} d\sigma \\ &= \langle f_i, v \rangle_{V_i}, \end{aligned}$$

with

$$B_{V_i}(u, v) = \int_{V_i} A\nabla u \cdot \nabla \bar{v} dx + \int_{\Gamma_{V_i}} \xi u \bar{v} d\sigma,$$

$f_i = \eta_i f + \nabla \cdot (u \nabla \eta_i) + \nabla \eta_i \nabla u + \nabla \cdot (A\nabla \tilde{u}_i)$ and

$$(4.8) \quad \|f_i\|_{V_i} \lesssim \|f\|_{V_i} + \|u\|_{1,V_i}.$$

Now, we can apply Corollary 4.2 if $x_i \in \Gamma_{\text{Diss}}$ or Lemma 2.2.2.1 of [9] if $x_i \in \Gamma_{\text{Dir}} \cup \Omega$, to obtain

$$\begin{aligned} |u_i|_{2,V_i} &\lesssim \|f_i\|_{V_i} + \|u_i\|_{1,V_i} + \||\xi|^{1/2}u_i\|_{\Gamma_{V_i}} \\ &\lesssim \|f\|_{V_i} + \|u\|_{1,V_i} + \|\tilde{u}_i\|_{2,V_i} + \||\xi|^{1/2}u\|_{\Gamma_{V_i}} \\ &\lesssim \|f\|_{V_i} + \|u\|_{1,V_i} + \||\xi|^{1/2}u\|_{\Gamma_{V_i}}, \end{aligned}$$

and

$$|\eta_i u|_{2,V_i} \lesssim |u_i|_{2,V_i} + \|\tilde{u}_i\|_{2,V_i} \lesssim \|f\|_{V_i} + \|u\|_{1,V_i} + \||\xi|^{1/2}u\|_{\Gamma_{V_i}}.$$

This estimate and the triangle inequality lead to

$$\begin{aligned} |u|_{2,\Omega} &\leq \sum_{i=1}^N |u_i|_{2,\Omega} \\ &\lesssim \sum_{i=1}^N \left(\|f\|_{V_i} + \|u\|_{1,V_i} + \||\xi|^{1/2}u\|_{\Gamma_{V_i}} \right) \\ &\lesssim \|f\|_{\Omega} + \|u\|_{1,\Omega} + \||\xi|^{1/2}u\|_{\Gamma_{\text{Diss}}}, \end{aligned}$$

and we conclude with the help of (2.3). \square

5. THE GENERAL CASE

We now consider the general case where the boundary of Ω is not necessarily convex or globally $C^{1,1}$ or when Γ_{Dir} is empty or not. For the sake of simplicity, we focus on the case $A = I_n$, but similar results can be deduced for variable coefficients using the ideas developed below.

In this section, we also assume that Γ_{Dir} and Γ_{Diss} are piecewise $C^{1,1}$.

We also introduce two additional assumptions on Γ_{Diss} and Γ_{Dir} . The first additional assumption concerns some geometrical restrictions along the points where mixed boundary conditions are imposed.

Assumption 1. Γ_{Diss} is flat in a neighbourhood of each connected component of $\overline{\Gamma_{\text{Dir}}} \cap \overline{\Gamma_{\text{Diss}}}$. Furthermore for all $x \in \overline{\Gamma_{\text{Dir}}} \cap \overline{\Gamma_{\text{Diss}}}$, there exists $\varepsilon_x > 0$ small enough and a $C^{1,1}$ diffeomorphism Φ_x from a neighborhood N_x of 0 onto $B(x, \varepsilon_x)$ of x such that $\widehat{\Gamma_{\text{Dir}}} = \Phi_x^{-1}(\Gamma_{\text{Dir}} \cap \overline{B(x, \varepsilon_x)})$ and $\widehat{\Gamma_{\text{Diss}}} = \Phi_x^{-1}(\Gamma_{\text{Diss}} \cap \overline{B(x, \varepsilon_x)})$ are flat and the angle along $\widehat{\Gamma_{\text{Dir}}} \cap \widehat{\Gamma_{\text{Diss}}}$ is $\frac{\pi}{2}$. We then set $W_x = \Phi_x^{-1}(B(x, \varepsilon_x) \cap \Omega)$ that coincides with a hypercube near 0.

For the other points (recalling that Γ_{Diss} and Γ_{Dir} are open in \mathbb{R}^{n-1}), we require the next geometrical constraints.

Assumption 2. For all $x \in \Gamma_{\text{Diss}} \cup \Gamma_{\text{Dir}}$, there exists $\varepsilon_x > 0$ small enough such that either the boundary of $B(x, \varepsilon_x) \cap \Omega$ is convex or the boundary of Ω is $C^{1,1}$ near $B(x, \varepsilon_x) \cap \Gamma$. Furthermore in dimension 3, if $x \in \Gamma_{\text{Diss}}$ and if $B(x, \varepsilon_x) \cap \Omega$ is only convex, we assume that $B(x, \varepsilon_x) \cap \Gamma_{\text{Diss}}$ is piecewise flat.

Without loss of generality, in this last assumption we can always assume that $\bar{B}(x, \varepsilon_x) \cap \overline{\Gamma_{\text{Dir}}} = \emptyset$ if $x \in \Gamma_{\text{Diss}}$ (resp. $\bar{B}(x, \varepsilon) \cap \overline{\Gamma_{\text{Diss}}} = \emptyset$ if $x \in \Gamma_{\text{Dir}}$).

Under these assumptions, we have as before the

Theorem 5.1. *If Ω is a bounded domain such that Assumptions 1 and 2 hold and if ξ is constant on $B(x, \varepsilon_x)$ for all $x \in \Gamma_{\text{Diss}}$ such that $B(x, \varepsilon_x) \cap \Omega$ is only convex. Then the solution $u \in H_{\Gamma_{\text{Dir}}}^1(\Omega)$ of (2.1) with $A = I_n$ belongs to $H^2(\Omega)$ and satisfies (2.4).*

Proof. We start by fixing an adequate finite covering of the boundary of Ω . First for all $x \in \Gamma$, we fix ε_x from Assumptions 1 and 2. This yields an open covering $\cup_{x \in \Gamma} (B(x, \varepsilon_x) \cap \Gamma)$ of Γ . Hence we can extract a finite covering

$$\cup_{i=1}^J (B(x_i, \varepsilon_i) \cap \Gamma)$$

of Γ with $\varepsilon_i = \varepsilon_{x_i}$. Now we can fix a partition of unity $(\eta_i)_{i=1}^N$ such that the support of η_i is included into $B(x_i, \varepsilon_i)$ and

$$\sum_{i=1}^N \eta_i = 1 \text{ on } W,$$

where W is a neighborhood of Γ . Without loss of generality, we can assume that $\eta_i = 1$ in a neighborhood of x_i and that η_i is radial, namely

$$\eta_i(x) = \eta_i(|x - x_i|), \forall x \in B(x_i, \varepsilon_i).$$

For all $i = 1, \dots, N$, we look at $\eta_i u$ as the solution to the following problem (compare with (1.1))

$$\left\{ \begin{array}{ll} -\Delta(\eta_i u) = f_i & \text{in } V_i := B(x_i, \varepsilon_i) \cap \Omega, \\ \nabla(\eta_i u) \cdot \mathbf{n} + \xi(\eta_i u) = u \nabla \eta_i \cdot \mathbf{n} & \text{on } \partial V_i \setminus \overline{\Gamma_{\text{Dir}}}, \\ u = 0 & \text{on } \Gamma_{\text{Dir}} \cap \partial V_i, \end{array} \right.$$

where

$$f_i := \eta_i f + 2 \nabla \eta_i \cdot \nabla u + u \Delta \eta_i,$$

that belongs to $L^2(V_i)$ with

$$\|f_i\|_{V_i} \lesssim \|f\|,$$

owing to (2.3).

We distinguish four different cases:

1. if $x_i \in \Gamma_{\text{Diss}}$ and $B(x_i, \varepsilon_i) \cap \Gamma_{\text{Diss}}$ is $C^{1,1}$, then we can apply Theorem 4.3 (see its proof) to deduce that $\eta_i u$ belongs to $H^2(\Omega)$ with

$$(5.1) \quad \|\eta_i u\|_{2, V_i} \lesssim \|f_i\|_{V_i} \lesssim \|f\|.$$

2. if $x_i \in \Gamma_{\text{Diss}}$ and $B(x_i, \varepsilon_i) \cap \Gamma_{\text{Diss}}$ is only convex but is piecewise flat, then we can apply Theorem 3.2 because

$$(5.2) \quad \nabla \eta_i \cdot \mathbf{n} = 0 \text{ on } \Gamma_{\text{Diss}} \cap \bar{B}(x_i, \varepsilon_i).$$

In such a case, we still conclude that $\eta_i u$ belongs to $H^2(\Omega)$ and satisfies (5.1).

On the contrary if $B(x_i, \varepsilon_i) \cap \Gamma_{\text{Diss}}$ is only piecewise $C^{1,1}$ (which is allowed only in dimension 2 and is of interest when x_i is a corner), we cannot directly apply

- Theorem 3.2 to $\eta_i u$ because it does not satisfy the homogeneous absorbing boundary condition. But in view of the proof of Theorem 4.3, it suffices to find a lifting $\tilde{u}_i \in H_c^1(V_i) \cap H^2(V_i)$ satisfying (4.6) (with $A = I_n$) and (4.7). But in this case, we can use Theorem 1.5.2.8 of [9], because $(\nabla \eta_i \cdot \mathbf{n})u$ is zero near x_i . With the help of this lifting, we can apply Theorem 3.2 to $\eta_i u - \tilde{u}_i$ and conclude as in the first item.
3. if $x_i \in \Gamma_{\text{Dir}}$, then, as $\eta_i u$ belongs to $H_0^1(B(x_i, \varepsilon) \cap \Omega)$, by Theorem 2.2.2.3 or Theorem 3.2.1.2 of [9], we conclude that $\eta_i u$ belongs to $H^2(\Omega)$ and satisfies (5.1).
 4. if $x_i \in \overline{\Gamma_{\text{Dir}}} \cap \overline{\Gamma_{\text{Diss}}}$, then we first perform a change of variables

$$x = \Phi_i(\hat{x}),$$

with $\hat{x} \in N_{x_i}$ that transforms problem (2.1) in V_i into a similar problem in W_{x_i} but with an operator with variable coefficients. Denote by $\hat{u}_i(\hat{x}) = \eta_i(x)u(x)$. Since the angle along $\overline{\Gamma_{\text{Dir}}} \cap \overline{\Gamma_{\text{Diss}}}$ is $\frac{\pi}{2}$, we then perform an odd reflexion of \hat{u}_i in W_{x_i} with respect to $\overline{\Gamma_{\text{Dir}}}$. Up to some rotations, we can assume that $\overline{\Gamma_{\text{Dir}}}$ is perpendicular to the \hat{x}_n -axis and that W_{x_i} is included into the half-plane $\hat{x}_n > 0$. Then we denote by

$$R_i = \{(\hat{x}', \hat{x}_n) \in \mathbb{R}^n : (\hat{x}', |\hat{x}_n|) \in W_{x_i}\},$$

and define $O(\hat{u}_i)$ on R_i as follows:

$$O(\hat{u}_i)(\hat{x}', \hat{x}_n) = \begin{cases} \hat{u}_i(\hat{x}', \hat{x}_n) & \text{if } (\hat{x}', \hat{x}_n) \in W_{x_i}, \\ -\hat{u}_i(\hat{x}', -\hat{x}_n) & \text{if } (\hat{x}', -\hat{x}_n) \in W_{x_i}. \end{cases}$$

As usual, $O(\hat{u}_i)$ belongs to $H^1(R_i)$ and is solution of problem (2.1) in R_i with an operator with variable coefficients (but in $C^{0,1}$), a dissipative boundary condition on its whole boundary and a datum $O(\hat{f}_i)$. As R_i is smooth near 0, by Theorem 4.3 we deduce that $O(\hat{u}_i)$ belongs to $H^2(R_i)$ with

$$\|O(\hat{u}_i)\|_{2, R_i} \lesssim \|O(\hat{f}_i)\|_{W_i} = 2\|\hat{f}_i\|_{W_{x_i}} \lesssim \|f_i\|_{V_i} \lesssim \|f\|.$$

Restricting ourselves to W_{x_i} , we get

$$\|\hat{u}_i\|_{2, W_{x_i}} \lesssim \|f\|.$$

Performing the transformation back, we deduce that $\eta_i u$ belongs to $H^2(V_i)$ and satisfies (5.1).

All together, we have shown that in all cases, $\eta_i u$ belongs to $H^2(\Omega)$ and satisfies (5.1). Consequently u belongs to $H^2(W)$ for one neighborhood W of Γ and summing (5.1) on i , one has

$$(5.3) \quad \|u\|_{2, W} \lesssim \|f\|.$$

For the regularity in the interior of Ω , we fix a cut-off function $\psi \in \mathcal{D}(\Omega)$ such that

$$\psi = 1 \text{ on } \Omega \setminus W.$$

Then ψu can be seen as the solution of the Dirichlet problem in a smooth domain S included into Ω , its boundary being supposed to be included into the set where $\psi = 0$ with

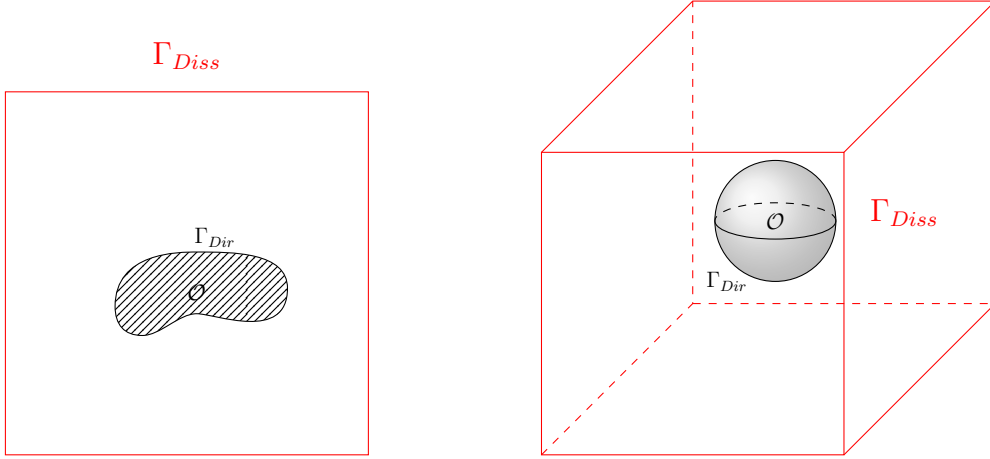

FIGURE 1. Examples of domains with an obstacle satisfying Assumptions 1 and 2 with Γ_{Diss} convex

a datum equal to

$$\psi f + 2\nabla\psi \cdot \nabla u + u\Delta\psi.$$

Hence ψu belongs to $H^2(S)$ with

$$\|\psi u\|_{2,S} \lesssim \|\psi f + 2\nabla\psi \cdot \nabla u + u\Delta\psi\|,$$

and consequently by (2.3)

$$(5.4) \quad \|\psi u\|_{2,S} \lesssim \|f\|.$$

We conclude with estimates (5.3) and (5.4). \square

Assumptions 1 and 2 are satisfied in a number of applications, as illustrated by Figures 1, 2 and 3. The first case depicted in Figure 1 (resp. 2) corresponds to the diffraction by an obstacle \mathcal{O} with a $C^{1,1}$ boundary Γ_{Dir} where the artificial boundary Γ_{Diss} is the boundary of a parallelepiped (resp. a ball) R such that $\overline{\mathcal{O}} \subset R$. Hence the domain Ω of interest is $R \setminus \mathcal{O}$, with the above choice of Γ_{Dir} and Γ_{Diss} . Since in this case they are disjoint, Assumption 1 is irrelevant, while Assumption 2 is automatically satisfied. The second example illustrated by Figure 3 concerns cavities builded up as follows: take a bounded domain D of \mathbb{R}^n with a $C^{1,1}$ boundary or being convex and fix a hyperplane Π for which $D \cap \Pi$ is not empty. If H is one of the half space induced by Π , the domain Ω is defined as $D \cap H$, $\Gamma_{Dir} = \partial D \cap H$ and $\Gamma_{Diss} = \Pi \cap D$. By the regularity assumption made on ∂D , Assumption 2 holds. In order to guarantee Assumption 1 we need that that the boundary of D is $C^{1,1}$ along the edge $\Pi \cap \partial D = \overline{\Gamma_{Diss}} \cap \overline{\Gamma_{Dir}}$ and that for all $x \in \Pi \cap \partial D$, the interior angle between Π and the hyperplane tangent to ∂D at x is less or equal to $\frac{\pi}{2}$. The verification of the Assumption 1 is made in the next Lemma.

Lemma 5.2. *For the family of cavities described here above, Assumption 1 holds.*

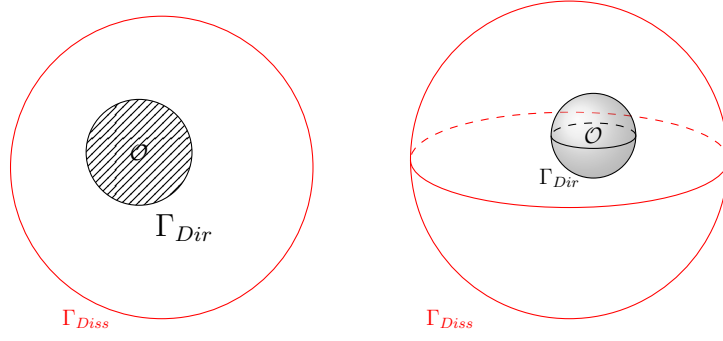

FIGURE 2. Examples of domains with an obstacle satisfying Assumptions 1 and 2 with Γ_{Diss} smooth

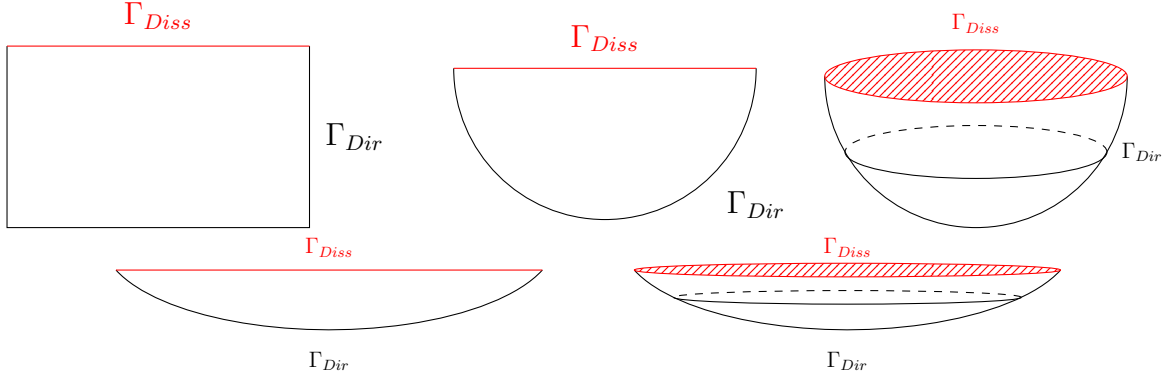

FIGURE 3. Examples of cavities satisfying Assumptions 1 and 2

Proof. We start with the two-dimensional case, i.e., $n = 2$. Fix one point $x \in \overline{\Gamma_{Diss}} \cap \overline{\Gamma_{Dir}}$, then by assumption there exist a neighborhood V of x and a local orthogonal coordinates system (y_1, y_2) such that V is a rectangle in this system, i.e.,

$$V = \prod_{j=1}^2 (-a_j, a_j),$$

with $a_j > 0$. Furthermore there exists a $C^{1,1}$ mapping $\varphi : (-a_1, a_1) \rightarrow \mathbb{R}$ such that

$$\begin{aligned} V \cap D &= \{(y_1, y_2) \in V; y_2 < \varphi(y_1), y_1 \in (-a_1, a_1)\}, \\ V \cap \partial D &= \{(y_1, y_2) \in V; y_2 = \varphi(y_1), y_1 \in (-a_1, a_1)\}. \end{aligned}$$

Furthermore, we can assume that the line Π is the line $y_1 = 0$ and by our assumption we then have

$$D \cap \Pi \cap V \subset \{(y_1, y_2) \in \mathbb{R}^2 : y_1 > 0\}.$$

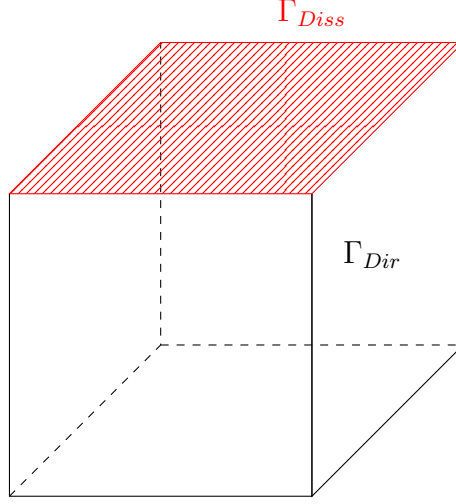

FIGURE 4. Exceptional cavity satisfying Theorem 5.1

Hence the change of variables

$$\begin{cases} \hat{y}_1 = y_1, \\ \hat{y}_2 = y_2 - \varphi(y_1), \end{cases}$$

allows to map the line $y_1 = 0$ into the line $\hat{y}_1 = 0$ and to flatten the curved boundary ∂D into the line $\hat{y}_2 = 0$. Furthermore the domain $D \cap \Pi \cap V$ will be mapped into W_x that coincides with the quarter plane $\hat{y}_1 > 0, \hat{y}_2 < 0$ near $(0, 0)$. As φ is $C^{1,1}$, this change of variables implies that the mapping

$$\Psi : (y_1, y_2) \rightarrow (y_1, y_2 - \varphi(y_1)),$$

is $C^{1,1}$ and invertible because

$$\det J_\Psi(y) = 1.$$

Hence its inverse Φ is a $C^{1,1}$ diffeomorphism, which proves that Assumption 1 holds.

The proof is fully similar in dimension 3. In that case, for $x \in \overline{\Gamma_{\text{Diss}}} \cap \overline{\Gamma_{\text{Dir}}}$, we can assume that there exists a local orthogonal coordinates system (y_1, y_2, y_3) such that ∂D is described near x by the curve $y_3 = \varphi(y_1, y_2)$ with a $C^{1,1}$ mapping φ , and $\Pi \equiv y_1 = 0$. Hence the change of variables

$$\begin{cases} \hat{y}_1 = y_1, \\ \hat{y}_2 = y_2, \\ \hat{y}_3 = y_3 - \varphi(y_1, y_2), \end{cases}$$

allows to map the plane $y_1 = 0$ into the plane $\hat{y}_1 = 0$ and to flatten the curved boundary ∂D into the plane $\hat{y}_3 = 0$. The remainder of the proof being the same as in dimension 2, we skip it. \square

The cavity illustrated in Fig. 4 is not covered by our general framework, while Theorem 5.1 remains valid in this case since at each corner belonging $\Gamma_{\text{Dir}} \cap \overline{\Gamma_{\text{Diss}}}$, two successive odd reflexions along the Dirichlet faces allow to apply Theorem 4.3.

REFERENCES

- [1] G. Alessandrini, A. Morassi, and E. Rosset. The linear constraints in Poincaré and Korn type inequalities. *Forum Math.*, 20(3):557–569, 2008.
- [2] I. Babuška. Error-bounds for finite element method. *Numer. Math.*, 16:322–333, 1970/1971.
- [3] H. Barucq, T. Chaumont-Frelet, and C. Gout. Stability analysis of heterogeneous Helmholtz problems and finite element solution based on propagation media approximation. *Math. Comp.*, 86(307):2129–2157, 2017.
- [4] H. Brezis. *Functional analysis Sobolev spaces and partial differential equations*. Springer, 2011.
- [5] T. Chaumont-Frelet and S. Nicaise. High-frequency behaviour of corner singularities in Helmholtz problems. Accepted for publication in M2AN: Math. Model. Numer. Anal., 2018.
- [6] M. Costabel and M. Dauge. A singularly perturbed mixed boundary value problem. *Comm. Partial Differential Equations*, 21(11-12):1919–1949, 1996.
- [7] J. Dardé and S. Staboulis. Electrode modelling: the effect of contact impedance. *ESAIM Math. Model. Numer. Anal.*, 50(2):415–431, 2016.
- [8] X. Feng and H. Wu. hp-discontinuous Galerkin methods for the Helmholtz equation with large wave number. *Mathematics of Computation*, 80:1997–2024, 2011.
- [9] P. Grisvard. *Elliptic problems in nonsmooth domains*, volume 24 of *Monographs and Studies in Mathematics*. Pitman, Boston–London–Melbourne, 1985.
- [10] N. Hyvönen. Complete electrode model of electrical impedance tomography: approximation properties and characterization of inclusions. *SIAM J. Appl. Math.*, 64(3):902–931, 2004.
- [11] N. Hyvönen and L. Mustonen. Smoothed complete electrode model. *SIAM J. Appl. Math.*, 77(6):2250–2271, 2017.
- [12] H.-C. Kaiser, H. Neidhardt, and J. Rehberg. Macroscopic current induced boundary conditions for Schrödinger-type operators. *Integral Equations Operator Theory*, 45(1):39–63, 2003.
- [13] N. G. Meyers. Integral inequalities of Poincaré and Wirtinger type. *Arch. Rational Mech. Anal.*, 68(2):113–120, 1978.
- [14] E. Somersalo, M. Cheney, and D. Isaacson. Existence and uniqueness for electrode models for electric current computed tomography. *SIAM J. Appl. Math.*, 52(4):1023–1040, 1992.
- [15] R. Tezaur, I. Kalashnikova, and C. Farhat. The discontinuous enrichment method for medium-frequency Helmholtz problems with a spatially variable wavenumber. *Comput. Methods Appl. Mech. Engrg.*, 268:126–140, 2013.
- [16] W. L. Wendland, E. Stephan, and G. C. Hsiao. On the integral equation method for the plane mixed boundary value problem of the Laplacian. *Math. Methods Appl. Sci.*, 1(3):265–321, 1979.
- [17] H. Wu. Pre-asymptotic error analysis of cip-fem and fem for the helmholtz equation with high wave number. part i: linear version. *IMA J. Numer. Anal.*, 34:1266–1288, 2014.
- [18] L. Zhu and H. Wu. Pre-asymptotic error analysis of cip-fem and fem for the helmholtz equation with high wave number. part ii: hp version. *SIAM J. Numer. Anal.*, 51(3):1828–1852, 2013.

T. CHAUMONT-FRELET, CERMICS, ÉCOLE DES PONTS PARISTECH, CHAMPS SUR MARNE, FRANCE
E-mail address: `theophile.chaumont@enpc.fr`

S. NICAISE, UNIV. VALENCIENNES, EA 4015 - LAMAV - FR CNRS 2956, F-59313 VALENCIENNES,
FRANCE
E-mail address: `Serge.Nicaise@uphf.fr`

J. TOMEZYK, UNIV. VALENCIENNES, EA 4015 - LAMAV - FR CNRS 2956, F-59313 VALENCI-
ENNES, FRANCE
E-mail address: `Jerome.Tomezyk@uphf.fr`