



HAL
open science

Fusion of Model-based and Data-based Fault Diagnosis Approaches

Amel Slimani, Pauline Ribot, Elodie Chanthery, N Rachedi

► **To cite this version:**

Amel Slimani, Pauline Ribot, Elodie Chanthery, N Rachedi. Fusion of Model-based and Data-based Fault Diagnosis Approaches. 10th IFAC Symposium on Fault Detection, Supervision and Safety for Technical Processes, SAFEPROCESS 2018, Aug 2018, Varsovie, Poland. hal-01882327

HAL Id: hal-01882327

<https://hal.science/hal-01882327v1>

Submitted on 26 Sep 2018

HAL is a multi-disciplinary open access archive for the deposit and dissemination of scientific research documents, whether they are published or not. The documents may come from teaching and research institutions in France or abroad, or from public or private research centers.

L'archive ouverte pluridisciplinaire **HAL**, est destinée au dépôt et à la diffusion de documents scientifiques de niveau recherche, publiés ou non, émanant des établissements d'enseignement et de recherche français ou étrangers, des laboratoires publics ou privés.

Fusion of Model-based and Data-based Fault Diagnosis Approaches

A. Slimani^{*,**} P. Ribot^{*} E. Chanthery^{*} N. Rachedi^{**}

^{*} LAAS-CNRS, Université de Toulouse, CNRS, INSA, UPS, Toulouse, France (e-mail: [echanthe, pribot]@laas.fr)

^{**} Altran, France (e-mail: nedjemi.rachedi@altran.com)

Abstract: This paper presents a generic approach that combines model-based and data-based methods for fault detection and diagnosis. A proposed generic representation framework is used to express the different diagnosis results and to merge them without taking into account neither their internal characteristics, nor the nature of their outputs. Within this framework, the generic approach is performed in two steps. The first step consists in operating several diagnosis methods using the system measurements. The second step deals with the fusion of various methods results. This diagnosis approach is evaluated and tested on an anti-lock braking system. Simulations show that methods combination and results fusion make our diagnosis approach more efficient.

Keywords: Model-based diagnosis, data-based diagnosis, parallel combination, fusion strategy.

1. INTRODUCTION

With the technology development, modern industrial systems have become very complex. They are subjected to very high stress which can lead to faults and failures occurrence. At the same time, maintenance and safety requirements are essential and have become economical and technical challenges for companies. Therefore, it is crucial to develop modern methods able to detect and isolate faults in these systems. To answer this issue, different approaches have been developed by both of the automatic control and the artificial intelligence communities.

Depending on the available knowledge on the system, it is possible to distinguish two main types of fault diagnosis methods: model-based and data-based approaches. The model-based approaches use a mathematical representation based on the system physical laws. These methods are very efficient if the system model is sufficiently accurate. However a model is often hard to obtain. On the other hand, data-driven methods are useful when the system model is not available. They rely on the use of the accessible sensors' data. Each approach has its own advantages and drawbacks. Moreover, the satisfaction of all the industrial requirements in terms of performances is always difficult to obtain when using distinctly the conventional methods. Recent researches mention that the combination of several methods may potentially derive benefits from each approach and overcome their eventual limitations [Tidriri et al. (2016), Ghosh et al. (2011)].

In this work, in the same logic, we aim at strengthening diagnosis methods, while overcoming the shortcomings by an original combination approach resulting on more reliable diagnosis results. The main contribution of the article is to propose a generic approach of combination, whatever the type of the used diagnosis methods (data-based or model-based).

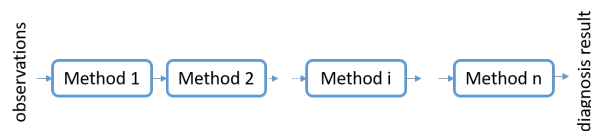

Fig. 1. Serial combination

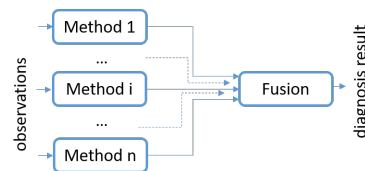

Fig. 2. Parallel combination

This paper is organized as follows. Section 2 introduces related work on diagnosis results fusion. Section 3 proposes a generic method for the fusion of heterogeneous diagnosis results. Section 4 presents the case study and the results we obtained. Section 5 concludes the article and presents some perspectives.

2. RELATED WORK

To enhance diagnosis performances, a considerable number of research studies have addressed the track of the conventional approaches combination.

In a serial combination topology (Fig.1), n diagnosis methods are put one after the other in series, so that each method takes as input the output provided by its upstream method. The methods succession increases the global efficiency through the confirmation of each result. Thus, this combination improves the decision-making by reducing the ambiguity and increasing diagnosis accuracy. However, in this architecture the first method must have good performances, since the consequences of its bad results will be propagated all along the chain. In addition,

the serial combination requires some *a priori* knowledge of the methods and compatibility of methods' inputs and outputs is mandatory. The serial combination is used, either for data-based diagnosis methods, in order to improve the classification accuracy, or for model-based diagnosis methods to make the residual evaluation more reliable by reducing the false alarm rate. Ghosh et al. (2011) propose a serial combination in order to improve neural network classification accuracy by using a linear model based on the Kalman filter as a post processing step. The Kalman filter transforms the predicted outputs of the neural network into values closer to the desired outputs. This simple combination reduces the error of the neural network and improves classification performances.

In the parallel combination topology (Fig.2), n diagnosis methods operate independently and solve the diagnosis problem in their own way; then a fusion is made between the outputs of the different diagnosis methods in order to make the final decision. This architecture is efficient in terms of reliability: if one of the diagnosis methods is reliable, and if the fusion strategy is well proceeded, the final diagnosis result is reliable. Moreover, a diagnosis result is always available, even if one of the used methods result is missing. Moreover, in terms of computation time, all methods connected in series have to be activated for a final result. Concerning the parallel combination topology, in case of time's lack, a set of methods could be discarded momentarily. In the literature, few works address the diagnosis problem where model-based and data-based approaches are combined. The greater part of them is focused on multi-classifier systems (MCS) which are a parallel combination of only data-based methods, like in Tidiri et al. (2016). Woźniak et al. (2014) present an up-to-date survey on MCS. The article also discusses fusion methods for decision making and provides a spectrum of the applications that are currently under development.

The diagnosis fusion is the process of integrating the results obtained from several diagnosis methods in order to make the final decision more precise and more reliable than the separated diagnosis results.

Several fusion strategies have been proposed in the literature. We can cite simple majority vote, weighted majority vote, the Bayesian approach, the fuzzy approach or the Dempster-Shafer approach. Ghosh et al. (2011) give an interesting review of these methods. The fusion is often applied when dealing with data-based approaches. The common point of all these methods is that for a given observation, they take as input the class chosen by each classifier, or the assigned probability (or else degree of belief) to each class by each classifier. Our work aims at applying indifferently these solutions to model-based and data-based diagnosis methods. So, we need to define a generic representation that can be used for the fusion of heterogeneous diagnosis results.

3. A GENERIC METHOD FOR MODEL-BASED AND DATA-BASED DIAGNOSIS APPROACHES FUSION

3.1 Overview

The proposed fusion architecture has to merge the outputs of different diagnosis methods without taking into account

neither their internal characteristics, nor their algorithms execution, nor the nature of their outputs. This architecture intends to be generic and applicable to any diagnosis problem. It is defined by a parallel combination topology, as shown in Fig. 3.

A fusion block connected in series has to merge the heterogeneous diagnosis results δ_i obtained by the different methods for the observation x to supply the final diagnosis decision $\Delta(x)$. This final diagnosis decision contains the most likely operating mode m_* for the system. The fusion block transforms the diagnosis results δ_i into generic representations Δ_i which are then combined through a fusion strategy.

3.2 Criteria for selecting diagnosis methods

Diagnosis methods are combined to take advantage of each of them in order to improve diagnosis efficiency. Two criteria are used to define the best combination of diagnosis methods: complementarity and performance.

Complementarity Diagnosis methods are said to be complementary if the information they provide are of different natures. The complementarity helps to overcome some method limits and may improve the diagnosis efficiency and reliability. For example, complementarity in data-based methods can be obtained by using different training datasets for the different methods. However, this is only suitable for data-based methods for which a small difference in the datasets can lead to significant changes in diagnosis performance [Ghosh et al. (2011)]. Alternatively, complementarity can be achieved by using methods from different research domains (model-based, data-based, hybrid methods). In this case, each method performs independently and solves the diagnosis problem. This last type of combination will be studied in this paper.

Performance Selecting diagnosis methods with the highest performance is not necessarily the best solution to achieve a correct final diagnosis decision. However, it is necessary to ensure that the diagnosis results provided by the different methods will not be degraded by using a fusion strategy. The confusion matrix is a theoretical tool used to evaluate the performance of classification methods. It is obtained by comparing the observed data with the reference data for each method [Ghosh et al. (2011); Kuncheva (2002)]. The confusion matrix \mathcal{CM}^i for the i^{th} classifier is:

$$\mathcal{CM}^i = \begin{bmatrix} N_{00}^i & N_{01}^i & \cdots & N_{0q}^i \\ N_{10}^i & N_{11}^i & \cdots & N_{1q}^i \\ \vdots & \vdots & \cdots & \vdots \\ N_{q0}^i & N_{q1}^i & \cdots & N_{qq}^i \end{bmatrix} \quad i = 1, 2, \dots, n \quad (1)$$

where N_{jk}^i is the number of input samples from class j that are assigned to class k by the i^{th} method. It is possible to extend this result and to obtain a confusion matrix for model-based methods by generating a set of simulations for each operating mode.

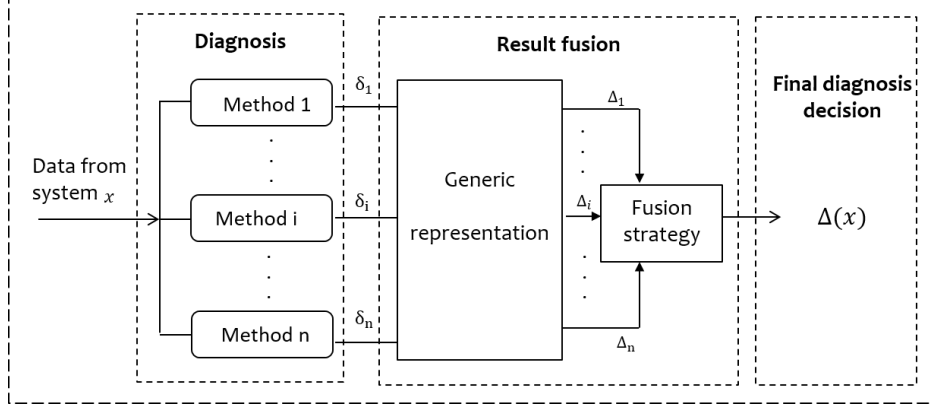

Fig. 3. Fusion architecture for diagnosis methods

3.3 Generic representation for diagnosis results

The combination of diagnosis methods requires a generic representation in order to express in the same frame of reference the heterogeneous results of diagnosis and to make the fusion task possible. Each method gives a result δ_i for each new observation x on the system. These results δ_i , for $i = 1 \dots n$, are heterogeneous, i.e. of different nature (signal, class, rank, ...). The purpose of this paper is to express these different data in a generic representation, so that they can be merged to produce a final diagnosis decision $\Delta(x)$ as shown in Fig. 4.

Let $\Delta_i \in \mathbb{R}^{q+1}$ be the generic representation of diagnosis results. Δ_i represents a vector whose coefficients are associated with the possible operating modes $\mathcal{M} = \{m_0, m_1, \dots, m_q\}$ of the system such that:

$$\Delta_i = \begin{bmatrix} \delta_{i0} \\ \vdots \\ \delta_{ik} \\ \vdots \\ \delta_{iq} \end{bmatrix} \in \mathbb{R}^{q+1}; \quad \begin{matrix} i = 1, \dots, n \\ k = 0, \dots, q \end{matrix} \quad \begin{cases} 0 \leq \delta_{ik} \leq 1 \\ \sum_{k=0}^q \delta_{ik} = 1. \end{cases} \quad (2)$$

Data-based diagnosis results representation Data-based diagnosis methods, like classification methods, compute for an element x a membership degree between 0 and 1 to each class C_k , for $k = 0, \dots, q$, representing a possible operating mode for the system [Bloch (1996)]. Let $D(x)$ be the membership vector of an element x containing all membership degrees associated to operating modes:

$$D(x) = [d^0 \dots d^k \dots d^q]^T \quad (3)$$

where d_k is the membership degree to the k^{th} class.

Most of classifiers perform an exclusive classification [Ghosh et al. (2011)], so $D(x)$ is represented by a binary vector with dimension equal to the number of classes, in which the value 1 indicates the class proposed by the classifier. This type of provided result is already in the generic form.

Some other classifiers compute rank-order results, which reflect the order of preference of the classifier provided propositions [Parker (2001)]:

$$Rank(x) = [rk^1 \dots rk^k \dots rk^q]^T \quad (4)$$

where rk^k is the rank assigned to the k^{th} class. The class placed in the first rank is the most admissible for the observation x and the class of the last rank is the least admissible. Some examples of ranked classifiers can be found in Provost and Fawcett (2001). The transformation of this type of result into the generic representation consists in building a binary vector with dimension equal to the number of classes, in which the value 1 indicates the label of the first class of ranks list:

$$j = \arg \max(rk^k) \quad (5)$$

$$\delta_{ik} = \begin{cases} 1 & \text{if } k = j \\ 0 & \text{otherwise} \end{cases} \quad (6)$$

where δ_{ik} is the coefficient of diagnosis result Δ_i , which is associated to the k^{th} operating mode and computed by the i^{th} diagnosis method.

Model-based diagnosis results representation Continuous model-based diagnosis methods are based on the principle of residual generation [Gertler (1998)]. These residuals are signals built from the model continuous equations where only measurable variables are involved. They are equal to zero when the system is fault-free in nominal mode, and they are equal to a non-zero value when some faults are present in the system. Fault detection is performed by monitoring the residual values. For fault isolation, the fault signature matrix is required to distinguish the effects of the different anticipated faults on the set of residuals [Gertler (1998)].

	f_0	f_1	f_2	...	f_q
r_0	0	0	1	...	1
r_1	0	1	1	...	0
\vdots					
r_p	0	1	0	...	1

Table 1. Example of a fault signature matrix

A fault signature matrix is illustrated in Table 1, where $\mathcal{F} = \{f_0, f_1, \dots, f_q\}$ is the set of anticipated faults in the system and $\mathcal{R} = [r_0, r_1, \dots, r_p]^T$ is the set of residuals generated from a continuous model-based diagnosis method. Let S_{f_k} be the signature of a given fault f_k , the set of fault signatures S_{f_i} , for $i = 0, \dots, q$ is represented by the columns of the fault signature matrix. Under the simple fault assumption (only one fault can occur on the system), a fault f_k can be directly associated to an operating mode

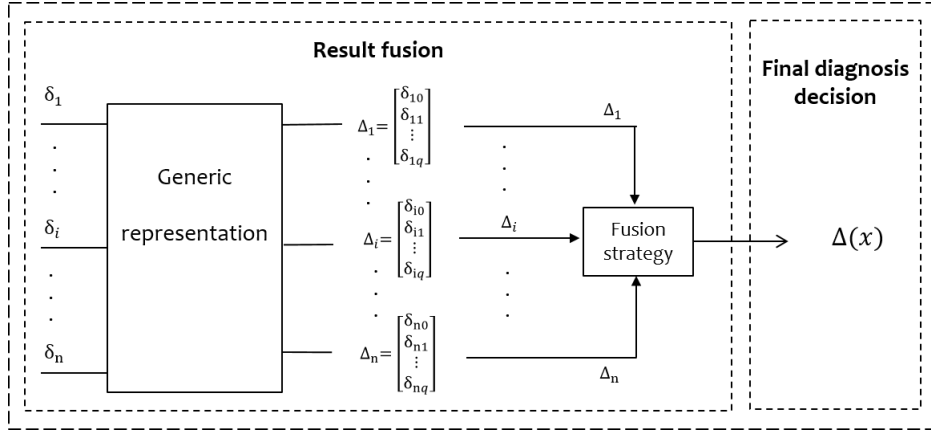

Fig. 4. Transformation of heterogeneous diagnosis results into a generic representation

m_k , for $k = 0, \dots, q$. In this case, when the residual values are equal to the fault signature S_{f_k} , it means the system may be in mode m_k .

If each fault signature is different from the others in the fault signature matrix, the system is diagnosable (all faults are detectable and isolable). If the system is known to be in operating mode m_j from residual values S_{f_j} in the fault signature matrix, the generic representation is:

$$\delta_{ik} = \begin{cases} 1 & \text{if } k = j \\ 0 & \text{else} \end{cases} \quad (7)$$

where k corresponds to the k^{th} line associated to the mode m_k of diagnosis results Δ_i obtained by the i^{th} diagnosis method.

If the system is non-diagnosable, the membership degrees in the generic representation may be equally distributed for each possible operating mode. Let $S_f = \{S_{f_k}\}$ be the set of fault signatures that are compatible with the residual values. Each S_{f_k} in S_f represents one possible operating mode m_k in the generic representation:

$$\delta_{ik} = \begin{cases} \frac{1}{\|S_f\|} & \text{for } k \text{ s.t. } S_{f_k} \in S_f \\ 0 & \text{else} \end{cases} \quad (8)$$

where $\|S_f\|$ is the cardinal of the set S_f .

3.4 Criteria for adopting a fusion strategy

In the case of health management, when some actions have to be decided in order to maintain or reconfigure the system, an ambiguous diagnosis result is difficult to interpret for undertaking the necessary actions. Probabilized information in diagnosis results make the decision-making more efficient even if only the most likely diagnosis hypothesis is considered: the fusion strategy is chosen in order to deal with probabilized information.

This probabilized information in diagnosis results may depend on a priori knowledge on the system and on performances of the combined methods. Some methods can be preferred to the others according to the available models, data or monitoring capabilities. The fusion strategy has to be able to weight method results with respects to these criteria. For safety reasons, some operating modes related to the presence of critical faults can be also conserved even if a low probability is computed. More details about the

criteria used to select a fusion strategy can be found in Ghosh et al. (2011).

4. DEMONSTRATION ON A CASE STUDY

4.1 The ABS system

An anti-lock braking system (ABS) is an active safety system that allows the wheels of vehicle (automobile, train, aircraft) to maintain tractive contact with the road surface according to driver inputs while braking, preventing the wheels from locking up and avoiding uncontrolled skidding. Fig. 5 illustrates a descriptive diagram of the ABS. The system consists of a speed sensor for each wheel, an electronic computer and a hydraulic system for regulating the braking pressure.

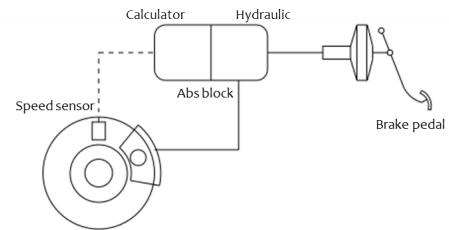

Fig. 5. Synoptic diagram of an anti-lock braking system (ABS)

The ABS model used in this work was initially proposed by Luo et al. (2010), where details on the model are available. This model considers the wheel speed and vehicle speed as measured variables and the force applied to the brake pedal as the input. One sensor fault and three parametric faults are considered. As explained in Luo et al. (2010), other components faults, such as those in the hydraulic valve and the calculator, are not considered because they are easily detectable by the current diagnostic troubleshooting codes. The wheel-speed-sensor fault (f_1) is modeled with two fault-severity cases: greater than 2% but less than 5% reduction in the nominal wheel speed ($f_{1.1}$), and greater than 5% reduction in the nominal wheel speed ($f_{1.2}$). The three considered parametric faults (f_2, f_3 and f_4) are changes in three parameters of the model: R_w , K_f and J_w . R_w appears in the vehicle model and is the radius of the wheel. It is used to model the tractive force

between the tire and the road surface, and the tractive torque between the wheel and the road surface. Two faults are considered for R_w : greater than 2% but less than 20% ($f_{2.1}$) decrease in R_w , and greater than 20% decrease in R_w ($f_{2.2}$). K_f represents the torque gain. It is used as the gain of the transfer function between the brake torque and the brake pressure. J_w is the rotating inertia of the wheel and is used in the vehicle model in the dynamic equation of the wheel speed. Variations between $\pm 2\%$ to $\pm 10\%$ of K_f and J_w parameters are considered as faults.

The list of considered faults considered in the ABS are summarized in Table 2.

Speed sensor	$f_{1.1}$	Sensor fault	(2% to 5% decrease)
	$f_{1.2}$	Sensor fault	(more than 5% decrease)
Wheel radius	$f_{2.1}$	R_w Fault	(2% to 20% decrease)
	$f_{2.2}$	R_w Fault	(more than 20% decrease)
Torque gain	f_3	K_f Fault	($\pm 2\%$ to $\pm 10\%$)
Wheel inertia	f_4	J_w Fault	($\pm 2\%$ to $\pm 10\%$)

Table 2. Considered fault list

We denote f_0 as the normal operating mode. We suppose that only simple faults occur on the system, so there exist 7 operating modes (m_0, \dots, m_6) for the ABS system, simply denoted $f_0, f_{1.1}, f_{1.2}, f_{2.1}, f_{2.2}, f_3$ and f_4 for the clarity of the paper.

4.2 Instantiation of the fusion architecture

Fig. 6 shows our instantiation of the proposed fusion architecture. This solution has been implemented and tested on the ABS system.

Diagnosis Methods Two model-based methods are used in parallel to generate four residuals. The design of these residuals is based on the work of Luo et al. (2010). The parity equations are used for the linear part of the system while the observer deals with the nonlinear part. Since faults $f_{1.1}$ and $f_{1.2}$ (resp. $f_{2.1}$ and $f_{2.2}$) can be isolated depending on the value of the residuals, a set of threshold tests is put in series to improve fault isolation. The result of this “parallel then series” combination of model-based methods is called δ_1 .

Two data-based methods are also used in parallel. Artificial Neural Networks (ANN) are chosen because they are particularly efficient when designing fault diagnosis schemes [Cruz and Wishart (2006)]. The architecture of the Neural Network consists in an input layer with two neurons (number of measured signals), a hidden layer with five neurons, and an output layer with seven neurons (number of operating modes). The tangent sigmoid function was used as the transfer function both from the input layer to the hidden layer and from the hidden layer to the output layer. The Neural Network was trained using the Levenberg–Marquardt back-propagation algorithm in the “Neural Network Toolbox” of Matlab. The result of the ANN method is called δ_2 .

Support Vector Machines (SVM) are used to detect and to isolate faults directly from the two measured variables of the system. The SVMs are known to be binary classifiers,

while the ABS case study has seven operating modes. In order to solve this problem, several approaches have been proposed to extend the binary SVMs to the case of multi-classification. A generalization of these approaches was proposed in 1995 under the name ECOC (error-correcting output codes) [Dietterich and Bakiri (1995)]. The two most popular approaches are called “one versus all” and “one versus one” [Hsu and Lin (2002)]. The “one versus one” approach was preferred for this study, because its training time is shorter compared to the “one against all” approach [Hsu and Lin (2002)]. This method is implemented with the “Statistics and Machine Learning Toolbox” of Matlab. The result of the SVM method is called δ_3 .

Fusion Strategy Based on the criteria proposed in section 3.4, a Bayesian fusion strategy is used within the fusion architecture. The main interest of the Bayesian approach or more generally of the probabilistic approaches comes from the fact that they rely on a solid mathematical basis tested by numerous studies for many years.

Bayesian fusion strategy is a probabilistic method for fusing information from different sensors, based on Bayes theory. It is very popular in image fusion [Stathaki (2011)] but is also used for solving conflicts among multiple diagnosis methods [Ghosh et al. (2011)]. The idea is to estimate the *a posteriori* probability of attributing an observation x to an operating mode from the *a priori* knowledge of diagnosis performance of each individual method. The Bayes rule is used to calculate the *a posteriori* probability. The final decisions are then made based on the estimated value of the *a posteriori* probabilities. This strategy is usually applied to classification methods and we generalize it to heterogeneous diagnosis methods.

We denote by m_k^i the fact that the i^{th} diagnosis method decides that x belongs to the operating mode m_k . At the end of the diagnosis method, each method decides that x belongs to one operating mode m_*^i , where $*$ = $\text{argmax}_k(\delta_{ik})$ for $k = 0, \dots, q$. For the clarity of the following, we also simplify the notation $x \in m_k$ by m_k .

The Bayesian fusion algorithm used in this work consist of the following steps.

Step 1: Computation of *a priori* probabilities of operating modes.

This step consists in calculating the *a priori* probability that the i^{th} diagnosis method assigns the observation x to the operating mode m_k while the true operating mode is m_j . These probabilities are directly computed based on the confusion matrix of each method. For $k = 0, \dots, q$:

$$P(m_k^i|m_j) = \frac{N_{kj}^i}{\sum_{j=0}^q N_{kj}^i}, \quad i = 1, \dots, n. \quad (9)$$

Step 2: Decision fusion.

This step consists in computing the *a posteriori* probability $P(m_k|m_*^1, \dots, m_*^n)$ of each operating mode from the decision of each diagnosis method, using the Bayes rule, while $P(m_k)$ is the k -th fault occurrence probability. For $k = 0, \dots, q$:

$$P(m_k|m_*^1, \dots, m_*^n) = \frac{P(m_k)P(m_*^1, \dots, m_*^n|m_k)}{\sum_{j=0}^q P(m_j)P(m_*^1, \dots, m_*^n|m_j)} \quad (10)$$

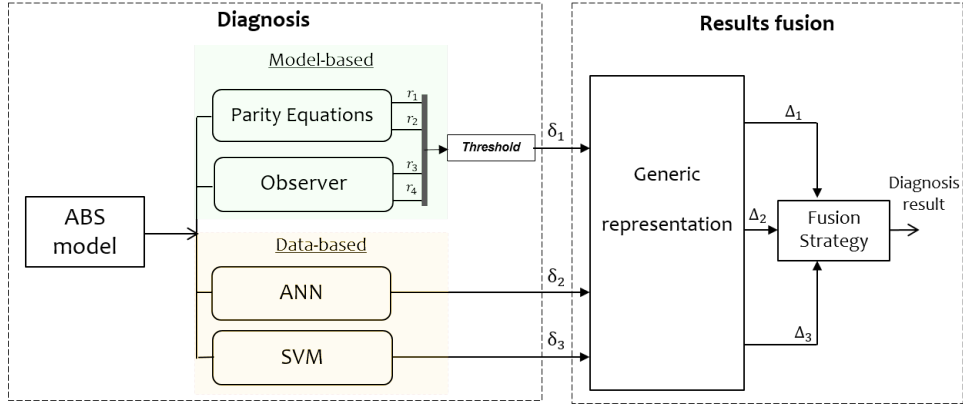

Fig. 6. Descriptive diagram of the combination framework.

where $P(m_k)$ is the probability for the system to be in operating mode m_k .

We can assume that the diagnosis methods to be combined are independent:

$$P(m_*^1, \dots, m_*^n | m_j) = \prod_{i=1}^n P(m_*^i | m_j). \quad (11)$$

So Equation 10 is simplified:

$$P(m_k | m_*^1, \dots, m_*^n) = \frac{P(m_k) \prod_{i=1}^n P(m_*^i | m_k)}{\sum_{j=0}^q P(m_j) \prod_{i=1}^n P(m_*^i | m_j)} \quad (12)$$

Step 3: Decision rule.

Finally the operating mode with the maximum *a posteriori* probability is considered to be the operating mode of the system:

$$\Delta(x) = \arg \max_{k=0, \dots, q} [P(m_k | m_*^1, \dots, m_*^n)]. \quad (13)$$

In case of non-diagnosable faults where each fault has the same weight, the diagnosis remains ambiguous and a set of operating modes can be returned. In this case, Equation 13 is adapted and the operating modes with the maximum *a posteriori* probability are considered to be the operating modes of the system.

4.3 Results

The four diagnosis methods were implemented on Matlab and tested on the ABS system. The training data were generated from model simulation by introducing the different faults in the system model and the confusion matrices are obtained¹.

Table 3 gives the ABS fault signature matrix obtained from model-based diagnosis methods (parity space and observer). It can be seen that all the faults are detectable, except f_4 , which is not detected due to the low magnitude of the fault. One naive solution could be the reduction of the threshold levels, but it could lead to an increase in the probability of false alarms. $f_{1.1}$ and $f_{1.2}$ (respectively $f_{2.1}$ and $f_{2.2}$) are not isolable as they have the same fault signature. Obviously these faults differ only on the magnitude of parameters variation. f_3 and f_4 are isolable. Thresholds (in series) are selected such that the false alarm

¹ available on <https://homepages.laas.fr/echanthe/papers/ABSfusion.htm>

rate is acceptable and that $f_{1.1}$ and $f_{1.2}$ (respectively $f_{2.1}$ and $f_{2.2}$) become isolable.

	f_0	$f_{1.1}$	$f_{1.2}$	$f_{2.1}$	$f_{2.2}$	f_3	f_4
r_1	0	1	1	1	1	0	0
r_2	0	0	0	0	0	1	0
r_3	0	1	1	0	0	0	0
r_4	0	0	0	1	1	0	0

Table 3. ABS fault signature matrix obtained from model-based diagnosis methods.

Both data-based methods (SVM/ANN) do not detect the sensor faults $f_{1.1}$ and $f_{1.2}$, because the effect of these faults does not appear for a long time in the measured outputs. Indeed, the controller compensates the effect of the sensor's faults as soon as they appear, to maintain the reference input. Therefore, there is not enough data illustrating these faults to efficiently train the data-based methods. Both methods isolate the other faults.

Table 4 shows a summary of the fault detection and isolation results by each diagnosis method (model-based diagnosis with thresholds, ANN and SVM methods).

	f_0	$f_{1.1}$	$f_{1.2}$	$f_{2.1}$	$f_{2.2}$	f_3	f_4
MBD + threshold	✓	✓	✓	✓	✓	✓	No
SVM	✓	No	No	✓	✓	✓	✓
ANN	✓	No	No	✓	✓	✓	✓

Table 4. Fault detection/isolation with data-based diagnosis methods.

Fusion To illustrate the fusion procedure, the case of the sensor fault $f_{1.1}$ is studied. This fault is detected and isolated using the model-based method but it is not detectable by the two data-based methods. The model-based approaches and the thresholds in series detect and isolate the fault, so that $\delta_1 = [f_{1.1}]$. The generic representation of this result is $\Delta_1 = [0 \ 1 \ 0 \ 0 \ 0 \ 0 \ 0]^T$ and $m_*^1 = f_{1.1}$. The second method (ANN) diagnoses the normal operating mode: $\delta_2 = \Delta_2 = [0.9072 \ 0.0072 \ 0.016 \ 0.032 \ -0.0004 \ 0.0165 \ 0.0206]^T$, and $m_*^2 = f_0$. The third method (SVM) also diagnoses the normal operating mode: $\delta_3 = \Delta_3 = [1 \ 0 \ 0 \ 0 \ 0 \ 0]^T$ and $m_*^3 = f_0$.

In order to take a decision, the Bayesian fusion strategy is applied to the generic outputs of the three methods. It consists in estimating the *a posteriori* probability of each operating modes.

Faults	$\Delta_{MBD+threshold}$	Δ_{ANN}	Δ_{SVM}	Final decision
f_0	$[1\ 0\ 0\ 0\ 0\ 0\ 0]^T$	$[0.85\ 0.05\ 0.02\ 0.01\ 0.01\ 0.02\ 0.05]^T$	$[1\ 0\ 0\ 0\ 0\ 0\ 0]^T$	Normal Operating f_0
$f_{1.1}$	$[0\ 1\ 0\ 0\ 0\ 0\ 0]^T$	$[0.9\ 0.01\ 0.01\ 0.03\ 0.00\ 0.01\ 0.02]^T$	$[1\ 0\ 0\ 0\ 0\ 0\ 0]^T$	Operating mode $f_{1.1}$
$f_{1.2}$	$[0\ 0\ 1\ 0\ 0\ 0\ 0]^T$	$[0.56\ 0.12\ 0.16\ 0.16\ 0.00\ 0.024\ 0.04]^T$	$[1\ 0\ 0\ 0\ 0\ 0\ 0]^T$	Operating mode $f_{1.2}$
$f_{2.1}$	$[0\ 0\ 0\ 1\ 0\ 0\ 0]^T$	$[0.0\ 0.01\ 0.03\ 0.9\ 0.0\ 0.02\ 0.02]^T$	$[0\ 0\ 0\ 1\ 0\ 0\ 0]^T$	Operating mode $f_{2.1}$
$f_{2.2}$	$[0\ 0\ 0\ 0\ 1\ 0\ 0]^T$	$[0.01\ 0.02\ 0.03\ 0.0\ 0.93\ 0.0\ 0.0]^T$	$[0\ 0\ 0\ 0\ 1\ 0\ 0]^T$	Operating mode $f_{2.2}$
f_3	$[0\ 0\ 0\ 0\ 0\ 1\ 0]^T$	$[0.0\ 0.0\ 0.0\ 0.0\ 0.0\ 0.96\ 0.03]^T$	$[0\ 0\ 0\ 0\ 0\ 1\ 0]^T$	Operating mode f_3
f_4	$[1\ 0\ 0\ 0\ 0\ 0\ 0]^T$	$[0.01\ 0.02\ 0.02\ 0.0\ 0.0\ 0.02\ 0.92]^T$	$[0\ 0\ 0\ 0\ 0\ 0\ 1]^T$	Operating mode f_4

Table 5. Diagnosis results before and after the fusion.

The *a posteriori* probability $P(f_{1.1}|m_*^1, m_*^2, m_*^3)$ is estimated using the Bayes rule:

$$P(f_{1.1}|m_*^1, m_*^2, m_*^3) = \frac{P(f_{1.1}) \prod_{i=1}^3 P(m_*^i|f_{1.1})}{\sum_{k=1}^7 P(m_k) \prod_{k=1}^3 P(m_*^i|m_k)} \quad (14)$$

where $P(m_k)$ is the probability for the system to be in operating mode m_k , which is assumed to be the same for all the operating modes, then $P(m_k) = 1/7$, for $k = 1 \dots 7$. The *a posteriori* probability obtained in this case is $P(f_{1.1}|m_*^1, m_*^2, m_*^3) = 0.778$. Following the same reasoning, $P(f_0|m_*^1, m_*^2, m_*^3) = 0.1111$.

Comparing all the *a posteriori* probabilities and following the decision rule (Equation 13), the final diagnosis decision is $\Delta(x) = f_{1.1}$.

Table 5 presents the diagnosis results of the different methods alone and the final diagnosis after the fusion. In the case where two methods provide wrong results and the third one has a correct result (case of $f_{1.1}$ and $f_{1.2}$) the final diagnosis decision is correct. This can be explained by the fact that the fusion calculations are implicitly based on the performance of the three methods. These results show the effectiveness of the proposed instantiation of the fusion architecture. It is able to detect and isolate all the faults, which is not the case considering each method separately.

5. CONCLUSION AND FUTURE WORK

This article proposes a generic method for the fusion of model-based and data-based diagnosis approaches. It combines results of one model-based method with two data-based methods (SVM and ANN). Its application on an ABS demonstrates the superiority of the combination of heterogeneous diagnosis methods and shows that the Bayesian strategy is efficient and easy to implement.

For future work, the proposed method will be tested on other case studies in order to validate its robustness to various data.

The criteria for selecting a fusion strategy have to be studied in more details to consider the generic combination framework in a global scheme of health management. A reconfiguration task and a prognosis task could be taken in account. The fusion strategy has to be able to weight method results with respects to these criteria. For safety reasons, some operating modes related to the presence of critical faults can be also conserved even if a low probability is computed.

It could be interesting to implement this generic fusion architecture in an open environment in order to give the opportunity to other researchers to test different

combinations of diagnosis methods and to propose their own strategies.

REFERENCES

- Bloch, I. (1996). Information combination operators for data fusion: a comparative review with classification. *IEEE Transactions on Systems, Man, and Cybernetics-Part A: Systems and Humans*, 26(1), 52–67.
- Cruz, J.A. and Wishart, D.S. (2006). Applications of machine learning in cancer prediction and prognosis. *Cancer informatics*, 2, 59.
- Dietterich, T.G. and Bakiri, G. (1995). Solving multiclass learning problems via error-correcting output codes. *Journal of artificial intelligence research*, 2, 263–286.
- Gertler, J. (1998). *Fault Detection and Diagnosis in Engineering Systems*. Marcel Dekker.
- Ghosh, K., Ng, Y.S., and Srinivasan, R. (2011). Evaluation of decision fusion strategies for effective collaboration among heterogeneous fault diagnostic methods. *Computers & chemical engineering*, 35(2), 342–355.
- Hsu, C.W. and Lin, C.J. (2002). A comparison of methods for multiclass support vector machines. *IEEE transactions on Neural Networks*, 13(2), 415–425.
- Kuncheva, L.I. (2002). Switching between selection and fusion in combining classifiers: An experiment. *IEEE Transactions on Systems, Man, and Cybernetics, Part B (Cybernetics)*, 32(2), 146–156.
- Luo, J., Namburu, M., Pattipati, K.R., Qiao, L., and Chigusa, S. (2010). Integrated model-based and data-driven diagnosis of automotive antilock braking systems. *IEEE Transactions on Systems, Man, and Cybernetics-Part A: Systems and Humans*, 40(2), 321–336.
- Parker, J. (2001). Rank and response combination from confusion matrix data. *Information fusion*, 2(2), 113–120.
- Provost, F. and Fawcett, T. (2001). Robust classification for imprecise environments. *Machine learning*, 42(3), 203–231.
- Stathaki, T. (2011). *Image fusion: algorithms and applications*. Academic Press.
- Tidriri, K., Chatti, N., Verron, S., and Tiplica, T. (2016). Bridging data-driven and model-based approaches for process fault diagnosis and health monitoring: A review of researches and future challenges. *Annual Reviews in Control*, 42, 63–81.
- Woźniak, M., Graña, M., and Corchado, E. (2014). A survey of multiple classifier systems as hybrid systems. *Information Fusion*, 16, 3–17.