



HAL
open science

Decentralized Diagnosis via Structural Analysis and Integer Programming

C G Pérez-Zuñiga, Elodie Chanthery, Louise Travé-Massuyès, Javier Sotomayor, Christian Artigues

► **To cite this version:**

C G Pérez-Zuñiga, Elodie Chanthery, Louise Travé-Massuyès, Javier Sotomayor, Christian Artigues. Decentralized Diagnosis via Structural Analysis and Integer Programming. 10th IFAC Symposium on Fault Detection, Supervision and Safety for Technical Processes, SAFEPROCESS 2018, Aug 2018, Varsovie, Poland. 7p. hal-01882324

HAL Id: hal-01882324

<https://hal.science/hal-01882324v1>

Submitted on 26 Sep 2018

HAL is a multi-disciplinary open access archive for the deposit and dissemination of scientific research documents, whether they are published or not. The documents may come from teaching and research institutions in France or abroad, or from public or private research centers.

L'archive ouverte pluridisciplinaire **HAL**, est destinée au dépôt et à la diffusion de documents scientifiques de niveau recherche, publiés ou non, émanant des établissements d'enseignement et de recherche français ou étrangers, des laboratoires publics ou privés.

Decentralized Diagnosis via Structural Analysis and Integer Programming

C. G. Pérez-Zuñiga^{*,**} E. Chanthery^{*} L. Travé-Massuyès^{*}
J. Sotomayor^{**} C. Artigues^{*}

^{*} LAAS-CNRS, Université de Toulouse, CNRS, INSA, Toulouse, France (e-mail: cgperez, elodie.chanthery, louise, artigues@laas.fr).

^{**} Engineering Department, Pontifical Catholic University of Peru, PUCP (e-mail: gustavo.perez, jsotom@pucp.edu.pe)

Abstract: Centralized fault diagnosis architectures are sometimes prohibitive for large-scale interconnected systems such as distribution systems, telecommunication networks, water distribution networks, fluid power systems. This paper presents a decentralized fault diagnosis method for continuous systems that only requires the knowledge of local models and limited knowledge of their neighboring subsystems. The notion of Fault-Driven Minimal Structurally Overdetermined (FMSO) set is used as the corner stone of the design of residual generators for the design of decentralized fault diagnosis for systems that have constraints of confidentiality, distance or limited access to some information. Binary integer linear programming (BILP) is used to optimize the choice of FMSO sets in each local subsystem.

Keywords: Model Based Diagnosis, Structural Analysis, Decentralized Systems.

1. INTRODUCTION

Two of the main tasks of fault diagnosis are fault detection and fault isolation. Fault detection consists in deciding if a fault has occurred in the system or not. If a fault has occurred, fault isolation consists in identifying the component responsible of the fault (Zaytoon and Sayed-Mouchaweh (2012)). Centralized fault diagnosis architectures are sometimes prohibitive for large-scale interconnected systems such as distribution systems, telecommunication networks, water distribution networks, fluid power systems. Actually this type of systems require sensing, processing and transmission of a large number of measured variables from various parts of the system. Some centralized approaches aim at selecting the tests that are currently needed. FlexDx, proposed by Krysander et al. (2010b), is one of these. However, centralized architectures can be very expensive and lack robustness for such large-scale interconnected systems. Thereby, decentralized control of interconnected systems has been deeply analyzed in the literature (Siljak (2011); Wang et al. (2017)) while decentralized fault diagnosis is being dealt only recently.

A decentralized diagnosis architecture is often interesting from a design point of view. It means that the design and development of diagnosers can be associated with the subsystems design and development, meeting the traditional organization in which the nominal functions are developed in parallel and then integrated together. Such approach has the advantage to consider diagnosis from the early stages of design, meaning that diagnosis requirements are better accounted for.

Researchers have developed several decentralized or distributed diagnosis schemes in the past, mostly in the discrete event framework (Debouk et al. (2000); Pencolé and

Cordier (2005); Wang et al. (2007); Cordier and Grastien (2007)). Pencolé and Cordier (2005) present a method to provide efficient online diagnosis to detect and isolate faults in large discrete event systems. This approach uses a decentralized model of the system and does not require a global model computation. Wang et al. (2007) propose a hierarchical framework for discrete event systems using architectures where local sites can issue several types of diagnosis decisions about the presence or absence of each fault including some conditional decisions. Cordier and Grastien (2007) present a decentralized computation of the diagnosis to avoid the state-explosion problem that appears when dealing with large systems. This decentralized representation relies on two independence properties: state and transition-independence, which are important to get a tractable representation of diagnosis in the context of both decentralized and incremental approaches.

Decentralized diagnosis methods for continuous systems have been proposed only recently. Zhang (2010) presents a decentralized fault detection scheme for continuous systems where a fault detection estimator is designed for each local subsystem by using local measurements and some communicated information directly from interconnected subsystems. However this approach is limited to a specific class of large-scale nonlinear systems such as nonlinear uncertain systems under certain assumptions. In Ferdowsi et al. (2012), a decentralized fault diagnosis and prognosis (FDP) methodology is proposed for large-scale systems by using local fault detectors (LFD) or observers for each subsystem based on the measured local states of the subsystem alone for nonlinear continuous-time systems. The disadvantage of this approach is that it requires upper bounds on modeling uncertainties and interconnection

functions to be known in nominal operating conditions to construct detection thresholds.

The diagnoser architecture developed in this paper is composed of optimally selected local diagnosers which work with local models of their subsystems. Diagnosis ambiguity among local diagnosers is resolved by a supervisory diagnoser at a higher level. This architecture is a natural match to the systems engineering process which proceeds with a functional decomposition of a system into subsystems. The architecture is hierarchically scalable, and implements diagnosis based on Analytical Redundancy Relations (ARRs). The approach to ARR generation and implementation adopted in the architecture is presented.

This work resumes the work of Chantry et al. (2016) and it must be considered as a direct continuation. In a similar way, the level of diagnosability deployed can be dynamically changed depending upon fault management requirements. This feature is known as *isolation on request* (Chantry et al. (2016)). The algorithm also inherits the property that was demonstrated in Chantry et al. (2016) that assesses that decentralized diagnosis with ARRs has equivalent diagnosability properties as a centralized diagnoser. Nevertheless, the proposed algorithm gains efficiency over the algorithm of Chantry et al. (2016) by taking benefit of the concept of FMSO set introduced in Pérez et al. (2016). As emphasized in Pérez et al. (2016), FMSO sets are preferred to Minimal Test Equation Supports (MTES) (Krysander et al. (2010a)) because even if MTES are a better solution to develop more powerful tests, they are not suited for minimizing the information shared by subsystems and the number of tests. It aims at optimizing the number of tests implemented for each subsystem while still guarantying maximal diagnosability, which is achieved by solving an optimization BILP (Binary Integer Linear Programming) problem for every subsystem (Sierksma and Zwols (2015); Vanderbei (2001)).

This paper is structured as follows: in section 2, some well known concepts of the structural approach are summarized and the notion of Fault-Driven Minimal Structurally Overdetermined (FMSO) set is presented. Section 3 presents some notions for decentralized fault diagnosis and different types of decentralized FMSO sets are introduced. Section 4 explains how to design the proposed decentralized diagnoser using a BILP problem formulation for local FMSO sets selection. The attitude determination and control system (ADCS) of a low earth orbit (LEO) satellite is then used to illustrate the application of the approach in section 5. Finally, a conclusion ends the paper.

2. BACKGROUND THEORY

Structural analysis allows to obtain structural models that are very useful for the design of model based diagnosis (MBD) systems. The main assumption is that each system component is described by one or several constraints, thereby, violation of at least one constraint indicates that the system component is faulty.

Let the system description consist of a set of n_e equations involving a set of variables partitioned into a set Z of n_Z known (or measured) variables and a set X of n_X unknown (or unmeasured) variables. We refer to the vector of known

variables as z and the vector of unknown variables as x . The system may be impacted by the presence of n_f faults that appear as parameters in the equations. The set of faults is denoted by F and we refer to the vector of faults as \mathbf{f} .

Definition 1. (System). A system, denoted $\Sigma(z, x, \mathbf{f})$ or Σ for short, is any set of equations relating z , x and \mathbf{f} . The equations $e_k(z, x) \subseteq \Sigma(z, x, \mathbf{f})$, $k = 1, \dots, n_e$, are assumed to be differential or algebraic in z and x .

Consider the illustrative example shown in Table 1 for which the system $\Sigma(z, x, \mathbf{f})$ is composed of six equations e_1 to e_6 relating the known variables $Z = \{z_1, z_2\}$, the unknown variables $X = \{x_1, x_2, x_3, x_4, x_5\}$ and the set of system faults $F = \{f_1, f_2, f_3\}$ besides a,b,c are constant parameters.

Relation	Expression
e_1	$\dot{x}_3 = e^{x_3} - a$
e_2	$x_3^2 = b\dot{x}_4 + f_1$
e_3	$z_1 = x_4$
e_4	$z_2 = x_1 + b^2 + x_4$
e_5	$\dot{x}_1 = e^{x_2} + x_5$
e_6	$\dot{x}_3 = x_4 + c + f_2$

Table 1. Differential illustrative example.

The *structural model* of the system $\Sigma(z, x, \mathbf{f})$, also denoted with some abuse by $\Sigma(z, x, \mathbf{f})$ or Σ in the following, can be obtained abstracting the functional relations. This abstraction leads to a bipartite graph $G(\Sigma \cup X \cup Z, \mathcal{A})$, or equivalently to $G(\Sigma \cup X, \mathcal{A})$, where $\mathcal{A} \subseteq A$ and \mathcal{A} is a set of edges such that $a(i, j) \in \mathcal{A}$ iff variable x_i is involved in equation e_j .

A bipartite graph with vertices partitioned into the sets Σ and X and edges \mathcal{A} is written $G = (\Sigma \cup X, \mathcal{A})$. The bipartite graph associated with the illustrative example is shown in Figure 1.

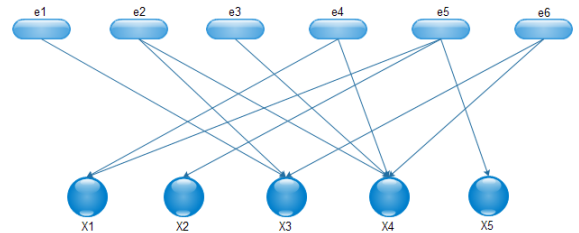

Fig. 1. The bipartite graph for the illustrative example.

2.1 Analytical Redundancy Relations

The main concept for residual generation in the case of continuous variable systems is analytical redundancy. Analytical redundancy relations (ARR) are equations that are deduced from an analytical model and only involve measured variables.

Definition 2. (ARR for $\Sigma(z, x, \mathbf{f})$). Let $\Sigma(z, x, \mathbf{f})$ be a system. Then, a relation $arr(z, \dot{z}, \ddot{z}, \dots) = 0$ is an Analytical Redundancy Relation (ARR) for $\Sigma(z, x, \mathbf{f})$ if for each z consistent with $\Sigma(z, x, \mathbf{f})$ the relation is fulfilled.

Definition 3. (Residual Generator for $\Sigma(z, x, \mathbf{f})$). A system taking a subset of the variables z as input, and generating a scalar signal arr , named *residual*, as output, is a residual

generator for the model $\Sigma(z, x, \mathbf{f})$ if, for all z consistent with $\Sigma(z, x, \mathbf{f})$, it holds that $\lim_{t \rightarrow \infty} arr(t) = 0$.

ARRs can be used to check if the measured variables z are consistent with the system model and as the basis of residual generators used for diagnosis purposes. Each ARR is sensitive to a set of faults and indicates that at least one of these faults has occurred if the corresponding residual is different from zero.

Several methods for computing sets with structural redundancy in $G(\Sigma \cup X, \mathcal{A})$ are based on the Dulmage-Mendelsohn (DM) canonical decomposition (Murota, 2000; Dulmage and Mendelsohn, 1958). It results in a partition of the system model Σ into three parts: the *structurally overdetermined* (SO) part Σ^+ with more equations than unknown variables; the *structurally just determined* part Σ^0 , and the *structurally underdetermined* part Σ^- with more unknown variables than equations (Blanke et al., 2006).

Definition 4. (Structural redundancy). The structural redundancy $\rho_{\Sigma'}$ of a set of equations $\Sigma' \subseteq \Sigma$ is defined as the difference between the number of equations and the number of unknown variables.

Definition 5. (PSO and MSO sets). A set of equations Σ is proper structurally overdetermined (PSO) if $\Sigma = \Sigma^+$ and minimally structurally overdetermined (MSO) if no proper subset of Σ is overdetermined (Krysander et al. (2010a)).

Definition 6. (Fault support). The fault support $F_{\Sigma'}$ of a set of equations $\Sigma' \subseteq \Sigma$ is defined as the set of faults that are involved in the equations of Σ' .

Since PSO and MSO sets have more equations than variables, they can be used to generate ARRs and residuals. MSO sets are of special interest since they are just overdetermined, i.e. they have structural redundancy 1. However, not all MSO sets are interesting to construct residual generators, in particular those that are not impacted by faults. Hence it is desirable to consider a fault-focused concept.

A Fault-Driven Minimal Structurally Overdetermined (FMSO) set can be defined as an MSO set of $\Sigma(z, x, \mathbf{f})$ whose fault support is not empty.

Let us define $Z_\varphi \subseteq Z$, $X_\varphi \subseteq X$, and $F_\varphi \subseteq F$ as the set of known variables, unknown variables involved in the FMSO set φ , and its fault support, respectively. We then have the following formal definition.

Definition 7. (FMSO set). A subset of equations $\varphi \subseteq \Sigma(z, x, \mathbf{f})$ is an FMSO set of $\Sigma(z, x, \mathbf{f})$ if (1) $F_\varphi \neq \emptyset$ and $\rho_\varphi = 1$ that means $|\varphi| = |X_\varphi| + 1$, (2) no proper subset of φ is overdetermined.

We also define the concept of *Clear Minimal Structurally Overdetermined* (CMSO) set as an MSO set of $\Sigma(z, x, \mathbf{f})$ whose fault support is empty.

Definition 8. (CMSO set). A subset of equations $\psi \subseteq \Sigma(z, x, \mathbf{f})$ is a CMSO set of $\Sigma(z, x, \mathbf{f})$ if (1) $F_\psi = \emptyset$ and $\rho_\psi = 1$ that means $|\psi| = |X_\psi| + 1$, (2) no proper subset of ψ is overdetermined.

3. DECENTRALIZED DIAGNOSIS

3.1 Notions for Decentralized Fault Diagnosis

A decentralized diagnosis architecture assumes a decomposition of the process in subsystems, each with its corresponding local diagnoser. The diagnostic task is coordinated by a supervisory diagnoser to ensure the consistency between local diagnosers. The supervisory levels may be more than one, depending on how the subsystems are recursively grouped together, hence forming a supervisory hierarchy of embedded subsystems. In this work, one hypothesis is that the decomposition in subsystems is guided by functional constraints. The system is decomposed into subsystems that implement primary functions and are then encapsulated to achieve higher level functions. The subsystems at each level can hence be seen as aggregations of subsystems of the directly lower level. An illustration of such hierarchy is given in Figure 2. The diagnosis system is decomposed into different local diagnosers which refer to the subsystems of the complete system. The local diagnosers process local measurements independently one from the others.

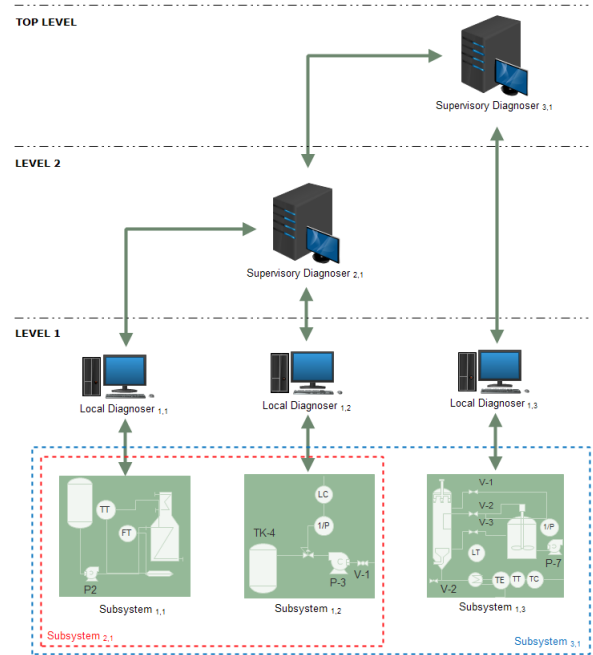

Fig. 2. Illustration of a decentralized diagnosis architecture.

In the following, the global level refers to no decentralization and, without loss of generality, we consider two hierarchical levels, the so-called local level and hierarchical level.

Let us consider the system Σ and define the following:

Definition 9. (Global FMSO set). A global FMSO set is an FMSO set of $\Sigma(z, x, \mathbf{f})$. The set of global FMSO sets is denoted by Φ .

Now, let us define the concepts of *detectable fault*, and *isolable fault* using the concept of FMSO set.

Definition 10. (Detectable fault). A fault $f \in F$ is detectable in the system $\Sigma(z, x, \mathbf{f})$ if there is an FMSO set $\varphi \in \Phi$ such that $f \in F_\varphi$.

The concept of isolation is based on determining the set of faults that can be isolated from a given fault.

Definition 11. (Isolable fault). Given two detectable faults f and f' of F , $f \neq f'$, f is isolable from f' if there exists an FMSO set $\varphi \in \Phi$ such that $f \in F_\varphi$ and $f' \notin F_\varphi$.

A decomposition of the system Σ into several subsystems $\Sigma_{j,i}$ is defined as a hierarchical organization of its equations on several levels as shown in Figure 3. $\Sigma_{j,i}$ represents the i^{th} subsystem at level j , with $j = 1, \dots, m$ and $i = 1, \dots, n_j$. The equations contained in the set $\Pi_{j,i}$ are equations that are only available at the j^{th} level, because of specific constraints, e.g. confidentiality, distance or difficult access, and they are therefore not available at the lower levels. Figure 3 illustrates the decentralized diagnosis architecture, each square with a dotted line corresponding to a subsystem.

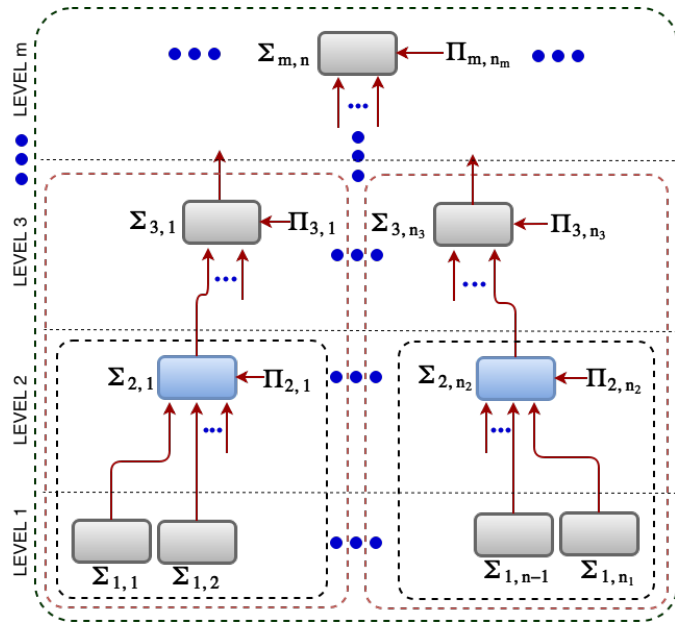

Fig. 3. Decentralized diagnosis architecture proposed.

Without loss of generality, this decomposition leads to subsystems denoted $\Sigma_{j,i}(z_{j,i}, x_{j,i}, \mathbf{f}_{j,i})$, with $j = 1, \dots, m$ and $i = 1, \dots, n_j$, where $z_{j,i}$ is the vector of known variables in $\Sigma_{j,i}$, $x_{j,i}$ the vector of unknown variables in $\Sigma_{j,i}$ and $\mathbf{f}_{j,i}$ refers to the vector of faults in $\Sigma_{j,i}$. The set of unknown variables $X_{j,i}$, known variables $Z_{j,i}$, and faults $F_{j,i}$ of $\Sigma_{j,i}$, are defined as the variables of X , Z , and F respectively, that are involved in the subsystem $\Sigma_{j,i}$.

Definition 12. (Local variables). The set of local variables of subsystem $\Sigma_{j,i}$, denoted $X_{j,i}^l$, is defined as the subset of variables of $X_{j,i}$ that are only involved in the subsystem $\Sigma_{j,i}$:

$$X_{j,i}^l = X_{j,i} \setminus \left(\bigcup_{\substack{k=1, \dots, m \\ l=1, \dots, n_k}} (X_{j,i} \cap X_{k,l}) \right) \text{ with } (k, l) \neq (j, i) \quad (1)$$

Definition 13. (Shared Variables). The set of shared variables of subsystem $\Sigma_{j,i}$, denoted as $X_{j,i}^s$, is defined as:

$$X_{j,i}^s = X_{j,i} \setminus X_{j,i}^l \quad (2)$$

The set of shared variables of the whole system Σ is denoted by X^s . It includes the set of variables involved at least in two subsystems.

3.2 Decentralized FMSO Sets

This section is based on the concept of Fault-Driven Minimal Structurally Overdetermined (FMSO) set proposed in the previous section and defines special types of FMSO sets to decentralized diagnostic design.

Definition 14. (Local FMSO set). φ is a local FMSO set of $\Sigma_{j,i}(z_{j,i}, x_{j,i}, \mathbf{f}_{j,i})$ if φ is an FMSO set of $\Sigma(z, x, \mathbf{f})$ and if $\varphi \subseteq \Sigma_{j,i}$, $X_\varphi \subseteq X_{j,i}$ and $Z_\varphi \subseteq Z_{j,i}^l$. The set of local FMSO sets of $\Sigma_{j,i}$ is denoted by $\Phi_{j,i}^l$. The set of all local FMSO sets is denoted by $\Phi^l = \bigcup_{\substack{j=1, \dots, m \\ i=1, \dots, n_j}} \Phi_{j,i}^l$.

Obviously, a local FMSO set for any subsystem $\Sigma_{j,i}$ is also an FMSO set of Σ , hence a global FMSO set.

We now define *shared FMSO sets* for a subsystem $\Sigma_{j,i}$ by considering shared variables as known variables and computing FMSO sets. FMSO sets including equations with shared variables are called *shared FMSO sets*.

Definition 15. (Shared FMSO set). φ is a shared FMSO set of subsystem $\Sigma_{j,i}(z_{j,i}, x_{j,i}, \mathbf{f}_{j,i})$ if φ is an FMSO set of $\tilde{\Sigma}_{j,i}(\tilde{z}_{j,i}, \tilde{x}_{j,i}, \tilde{\mathbf{f}}_{j,i})$, where $\tilde{z}_{j,i}$ is the vector of variables in $\tilde{Z}_{j,i} = Z_{j,i} \cup X_{j,i}^s$, $\tilde{x}_{j,i}$ is the vector of variables in $\tilde{X}_{j,i} = X_{j,i}^l$, and $\tilde{\mathbf{f}}_{j,i} = \mathbf{f}_{j,i}$. The set of shared FMSO sets for $\Sigma_{j,i}$ is denoted by $\Phi_{j,i}^s$. The set of all shared FMSO sets is denoted by $\Phi^s = \bigcup_{\substack{j=1, \dots, m \\ i=1, \dots, n_j}} \Phi_{j,i}^s$.

From the above definition, a shared FMSO set φ for subsystem $\Sigma_{j,i}(z_{j,i}, x_{j,i}, \mathbf{f}_{j,i})$ is such that $\varphi \subseteq \Sigma_{j,i}$, $X_\varphi \subseteq X_{j,i}^l$, $Z_\varphi \cap X_{j,i}^s \neq \emptyset$, and $Z_\varphi \subseteq (Z_{j,i} \cup X_{j,i}^s)$.

Definitions 14 and 15 can also be applied to CMSO sets to define *local CMSO sets* $\Psi_{j,i}^l$ and *shared CMSO sets* $\Psi_{j,i}^s$. The set of all shared CMSO sets is denoted by Ψ^s .

Definition 16. (Local CMSO set). ψ is a local CMSO set of $\Sigma_{j,i}(z_{j,i}, x_{j,i}, \mathbf{f}_{j,i})$ if ψ is an CMSO set of $\Sigma(z, x, \mathbf{f})$ and if $\psi \subseteq \Sigma_{j,i}$, $X_\psi \subseteq X_{j,i}$ and $Z_\psi \subseteq Z_{j,i}^l$. The set of local CMSO sets of $\Sigma_{j,i}$ is denoted by $\Psi_{j,i}^l$. The set of all local CMSO sets is denoted by $\Psi^l = \bigcup_{\substack{j=1, \dots, m \\ i=1, \dots, n_j}} \Psi_{j,i}^l$.

Definition 17. (Shared CMSO set). ψ is a shared CMSO set of subsystem $\Sigma_{j,i}(z_{j,i}, x_{j,i}, \mathbf{f}_{j,i})$ if ψ is an CMSO set of $\tilde{\Sigma}_{j,i}(\tilde{z}_{j,i}, \tilde{x}_{j,i}, \tilde{\mathbf{f}}_{j,i})$, where $\tilde{z}_{j,i}$ is the vector of variables in $\tilde{Z}_{j,i} = Z_{j,i} \cup X_{j,i}^s$, $\tilde{x}_{j,i}$ is the vector of variables in $\tilde{X}_{j,i} = X_{j,i}^l$, and $\tilde{\mathbf{f}}_{j,i} = \mathbf{f}_{j,i}$. The set of shared CMSO sets for $\Sigma_{j,i}$ is denoted by $\Psi_{j,i}^s$. The set of all shared CMSO sets is denoted by $\Psi^s = \bigcup_{\substack{j=1, \dots, m \\ i=1, \dots, n_j}} \Psi_{j,i}^s$.

4. OPERATIONAL PROCEDURE FOR DECENTRALIZED DIAGNOSIS

The decentralized diagnoser architecture developed in this section, illustrated by Figure 3, is composed of hierar-

Algorithm 1. Decentralized Diagnoser Design.

Given : $\Sigma_{j,i}(z_{j,i}, x_{j,i}, \mathbf{f}_{j,i})$, $j = 1, \dots, m$, $i = 1, \dots, n_j$

- 1: $n_0 = 1$, $E_{0,1} = \emptyset$; ▷ Init part
- 2: **for** $j \leftarrow 1$ to m **do** ▷ Main part
- 3: $\Delta_{j,i} \leftarrow$ Compute subsystems corresponding to level $j - 1$ that have links to subsystem i at level j ;
- 4: **for** $i \leftarrow 1$ to n_j **do**
- 5: $\Pi_{j,i} \leftarrow$ Load additional equations for $\Sigma_{j,i}$;
- 6: $\Sigma_{j,i} = \Pi_{j,i} \cup (\bigcup_{i \in \Delta_{j,i}} E_{j-1,i})$;
- 7: $\Phi_{j,i}^l \leftarrow$ Compute local FMSO sets of $\Sigma_{j,i}$;
- 8: Execute an optimal selection of computed FMSO sets by solving a BILP problem as presented in Subsection 4.2
- 9: Compute ARR for $\Sigma_{j,i}$ from selected FMSO sets
- 10: $ARR_{j,i} \leftarrow$ Compute analytical residual generators of $\Sigma_{j,i}$;
- 11: **if** there is any fault $f \in F_{j,i}$ not detectable or not isolable with the ARRs computed so far **then**
- 12: $\Phi_{j,i}^s \leftarrow$ Compute shared FMSO sets of $\Sigma_{j,i}$;
- 13: $\Psi_{j,i}^s \leftarrow$ Compute shared CMSO sets of $\Sigma_{j,i}$;
- 14: $E_{j,i} = \{e \in \Sigma / e \in \Phi_{j,i}^s \cup \Psi_{j,i}^s\}$;
- 15: **end if**
- 16: **end for**
- 17: **end for**

Result : Near-optimal distribution of ARRs on the hierarchy of subsystems that guarantee maximal fault isolability.

chically ordered diagnosers based on ARRs which are generated from the FMSO sets obtained for each system at each level. Diagnosis ambiguity among diagnosers of the same level, if any, is resolved by the diagnosers at higher levels. This architecture is a natural match to the systems engineering design process which proceeds with a functional decomposition of the system into subsystems that implement primary functions and are then encapsulated to achieve higher level functions. This architecture is hierarchically scalable.

4.1 An Algorithm for Decentralized Diagnoser Design

The diagnoser design is done *offline* and is implemented along the steps of algorithm 1. These steps are performed for each subsystem $\Sigma_{j,i}$ $i = 1, \dots, n_j$ at each level $j = 1, \dots, m$, with a nested loop. For the first level, the subsystems are formed according to functional, geographical or privacy constraints. If the faults are not detectable or isolable at this level, aggregated subsystems are developed at level two and so on until the diagnosability objective is achieved.

At line 1, n_0 and $E_{0,1}$ are initial conditions for a virtual level 0 that allows us apply the recursive operations for the following levels.

The diagnosis hierarchy is constrained by the possible inter-level communication, which is defined by a set of bipartite graphs.

Definition 18. (Inter-level communication). The inter-level communication is represented by a set of $m - 1$ bipartite graphs $S_{j-1}^j(\mathbb{N}_{j-1}^j, \mathbb{L}_{j-1}^j)$, $j = 2, \dots, m$. $S_{j-1}^j(\mathbb{N}_{j-1}^j, \mathbb{L}_{j-1}^j)$ is a bipartite graph such that $\mathbb{N}_{j-1}^j = \mathbb{N}_{j-1} \cup \mathbb{N}_j$, where:

- $\mathbb{N}_{j-1} = \{n_{j-1,i}, i = 1, \dots, n_{j-1}\}$ is a set of nodes corresponding to the subsystems $\Sigma_{j-1,i}, i = 1, \dots, n_{j-1}$, of level $j - 1$,
- $\mathbb{N}_j = \{n_{j,i}, i = 1, \dots, n_j\}$ is a set of nodes corresponding to the subsystems $\Sigma_{j,i}, i = 1, \dots, n_j$, of level j ,
- $\mathbb{L}_{j-1}^j = \{l_{\nu,\xi}, \nu = 1, \dots, n_{j-1}, \xi = 1, \dots, n_j\}$ is a set of edges such that the edge $l_{\nu,\xi}$ between node $n_\nu \in \mathbb{N}_{j-1}$ and $n_\xi \in \mathbb{N}_j$ exists if communication is possible between subsystem $\Sigma_{j-1,\nu}$ at level $j - 1$ and subsystem $\Sigma_{j,\xi}$ at level j .

In Algorithm 1, the inter-level communication is taken into account by $\Delta_{j,i}$ (line 3), where $\Delta_{j,i} = \{\Sigma_{j-1,\nu} / l_{\nu,i}$ exists in $S_{j-1}^j(\mathbb{N}_{j-1}^j, \mathbb{L}_{j-1}^j)\}$, for $j = 2, \dots, m$, and $\Delta_{1,i} = \emptyset$. In other words, for $j = 2, \dots, m$ representing the level, $\Delta_{j,i}$ contains all subsystems of level $j - 1$ that have connection with subsystem $\Sigma_{j,i}$, i.e. subsystem i at level j .

Line 3 is a **for** instruction on the levels from 1 to m . At line 4, the set $\Delta_{j,i}$ is determined as defined above.

Then a loop is started that covers all subsystems from $i = 1$ to $i = n_j$ of level j (lines 4 to 16). The equations contained in the set $\Pi_{j,i}$ in Algorithm 1 (line 5) are additional equations that are only available at level j for forming subsystem $\Sigma_{j,i}$. The restriction on these equations may originate from different constraint types, e.g. confidentiality, distance and difficult access and they are not therefore available at level $j - 1$. $\Pi_{j,i}$ is loaded at line 5 and the new subsystem $\Sigma_{j,i}$ is formed at line 6 from the additional equations $\Pi_{j,i}$ and union of equations $E_{j-1,i}$ coming from the shared FMSO and CMSO sets of the connected subsystems (those in $\Delta_{j,i}$) of the previous level.

Local¹ FMSO sets for $\Sigma_{j,i}$ are computed at line 7 in Algorithm 1, then an optimal selection is made by solving the binary integer linear programming (BILP) problem presented in Subsection 4.2 (line 8). With selected FMSO sets, the set of ARRs for subsystem $\Sigma_{j,i}$ is computed at line 9. Shared FMSO and CMSO sets of subsystem $\Sigma_{j,i}$ are computed at lines 12 and 13 only if the faults of the "children" subsystems of the previous level are not isolable at this level (line 11). The equations included in shared FMSO and CMSO sets, denoted $E_{j,i}$ (line 14), are to be sent to the next level. The output of Algorithm 1 is a near-optimal distribution of FMSO sets and associated ARRs that guarantee to isolate all the isolable faults of the system.

Property 1. Algorithm 1 computes recursively, by developing the necessary levels, the set of optimal analytical residual generators that guarantee to isolate all the faults.

Proof 1. The proof of Property 1 relies on the results of Chantry et al. (2016), more particularly Proposition 1.

The diagnoser runs online as a hierarchical residual generator bank based on the local FMSO sets generated for each subsystem at each level. A standard fault signature matrix is used to identify the faults. Let us notice that the computations start with the residuals of the first level and they are carried out at the higher level only if all the

¹ Note that "local" refers to a given subsystem as defined in Definition 14 but this subsystem may be at any level of the hierarchy.

faults are not isolable at the current level. This is the idea of *isolation on request* (Chanthery et al. (2016)).

4.2 Problem Formulation of Local FSMO sets Selection

Within the set of local FMSO sets computed, we derive an integrated approach to determine a minimal set of FMSO sets that guarantee maximum isolability for subsystem $\Sigma_{j,i}$. The isolability degree is defined as the number of pairs of faults that are isolable.

Let Z_{φ_i} be a boolean variable that shows whether a FSMO set φ_i is selected or not. Given $f_{\varphi_i k l}$ as a boolean variable that indicates if the fault f_k is isolable from the fault f_l by using the FSMO set φ_i and let e_{kl} be a boolean variable that indicates if the two faults f_k and f_l are isolable.

The objective is to maximize the isolability minimizing the number of local FMSO sets $\Phi_{j,i}^l$. α is the weighting between the maximization of the isolability and the minimization of the number of chosen FMSO sets. The BILP model is the following:

$$\max(\alpha \sum_{(f_k, f_l) \in F_{j,i}} e_{kl} - (\alpha - 1) \sum_{\varphi_i \in \Phi_{j,i}^l} Z_{\varphi_i}) \quad (3)$$

Subject to:

$$\sum_{\varphi_i \in \Phi_{j,i}^l} f_{\varphi_i k l} Z_{\varphi_i} \geq e_{kl} \quad (4)$$

$$Z_{\varphi_i} \in \{0, 1\} \text{ for } \varphi_i \in \Phi_{j,i}^l, \quad (k, l) \in F_{j,i}, \quad \alpha \in [0, 1] \quad (5)$$

Equation (3) is the objective function of the BILP problem for selecting local FMSO sets. The constraint (4) is used to guarantee the maximum possible isolation for subsystem $\Sigma_{j,i}$, while (5) limits the solution space of the problem.

5. CASE STUDY: DECENTRALIZED DIAGNOSIS FOR AN ADCS OF A SATELLITE LEO

Low Earth orbit (LEO) satellites have geocentric orbits ranging in altitude from 180 km - 2000 km. This section presents the application of the decentralized fault diagnosis method on the Attitude Determination and Control System (ADCS) of a Low Earth Orbit satellite. This work is an improvement of the work presented in Chanthery et al. (2016) and Pérez et al. (2015).

The ADCS is composed by two subsystems: the attitude determination subsystem (ADS) and the attitude control subsystem (ACS).

The attitude determination subsystem (ADS) is composed of sensors which sense the rate and angular position of the satellite. An attitude estimate is achieved using a sensor fusion for rate and vector sensors (Pirmoradi et al. (2009)), which is provided as input to the attitude control subsystem (ACS). The ACS is composed of the control signal calculation and the actuators which provide the stabilizing and/or control torque to the satellite. The satellite under study is assumed to be a three-axis stabilized satellite in orbit around the earth. Here, reaction

wheels and magnetorquers are considered as actuators (Niemann (2003)).

The structure of the ADCS is abstracted as a set of constraints on a set of variables. Related information of such modelling can be founded in (Zuliana and Renuganth (2010); Pirmoradi et al. (2009)). Most constraints are composed of three behavioral relations corresponding to three axes. From the set of variables of the system, the sensed quantities form the set of observed variables with all the rest assumed to be unobserved. The general procedure for the diagnoser design starts with assuming a small set of observed quantities, and can be optionally expanded to fulfill diagnosis and isolation capability specifications.

The global model $\Sigma(z, x, \mathbf{f})$ for this system is composed of 42 equations e_1 to e_{42} that relate the set of known variables Z , the set of unknown variables X and the set of system faults F (Chanthery et al. (2016); Pérez et al. (2015)).

The natural decomposition of the ADCS system is an attitude control subsystem (ACS) as $\Sigma_{1,1}$ and an attitude determination subsystem (ADS) as $\Sigma_{1,2}$ as illustrated in Figure 4.

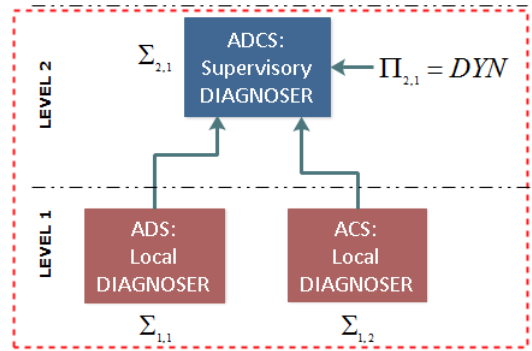

Fig. 4. Architecture of the decentralized diagnoser designed for the ADCS system.

The equations representing the dynamics of the satellite (DYN) denoted $\Pi_{2,1}$ are considered as additional equations that are only available at level 2 for forming subsystem $\Sigma_{2,1}$. The restriction on the (DYN) equations may originate from different constraint types, e.g. confidentiality, distance and difficult access and they not therefore available at level 1. The model decomposition of the ADCS system into subsystems $\Sigma_{1,1}$ and $\Sigma_{1,2}$ is given in Table 2.

Additional equations referring to the subsystem $\Sigma_{2,1}$ are the following :

$$\Pi_{1,1} = \Pi_{1,2} = \{\emptyset\} \quad (6)$$

$$\Pi_{2,1} = \{e_{25}, e_{26}, e_{27}\} \quad (7)$$

The hierarchical decomposition of this system is shown in Figure 4, where in level 1, the 2 subsystems $\Sigma_{1,1}$ and $\Sigma_{1,2}$ are composed 21 equations each one, in level 2 the necessary information with additional 3 equations in $\Pi_{2,1}$ is grouped in subsystem $\Sigma_{2,1}$.

5.1 Global FMSO Sets Computation

As a reference, the global FMSO sets are computed for the whole ADCS system considered globally in order to determine maximal fault isolation.

$$ACS = \Sigma_{1,1} = \begin{cases} \Sigma_{1,1} = \{e_1, e_2, e_3, e_4, e_5, e_6, e_7, \dots, e_{18}\} \\ F_{1,1} = \{f_{rw_x}, f_{rw_y}, f_{rw_z}\} \\ X_{1,1} = \{T_x, T_y, T_z, RW_{am_x}, RW_{am_y}, RW_{am_z}, \\ dRW_{am_x}, dRW_{am_y}, dRW_{am_z}, \\ RW_{\omega_x}, RW_{\omega_y}, RW_{\omega_z}\} \\ Z_{1,1} = \{\phi_{ref}, \theta_{ref}, \psi_{ref}, T_{cx}, T_{cy}, T_{cz}, W_{\omega_{xs}}, \\ W_{\omega_{ys}}, W_{\omega_{zs}}\} \end{cases}$$

$$ADS = \Sigma_{1,2} = \begin{cases} \Sigma_{1,2} = \{e_{22}, e_{23}, e_{24}, e_{25}, e_{26}, e_{27}, e_{38} \dots e_{42}\} \\ F_{1,2} = \{f_{vs_x}, f_{vs_y}, f_{vs_z}, f_{rs_x}, f_{rs_y}, f_{rs_z}\} \\ X_{1,2} = \{T_x, T_y, T_z, RW_{am_x}, RW_{am_y}, RW_{am_z}, \\ \psi_{est}, \theta_{est}, \phi_{est}, \psi_{est}, \theta_{est}, \phi_{est}, \psi, \\ \theta, \phi, \psi, \theta, \phi, \psi_{est1}, \theta_{est1}, \phi_{est1}, \psi_{est1}, \\ \theta_{est1}, \phi_{est1}, \psi_{est2}, \theta_{est2}, \phi_{est2}, \psi_{est2}, \\ \theta_{est2}, \phi_{est2}, \psi_{est3}, \theta_{est3}, \phi_{est3}, \\ \psi_{est3}, \theta_{est3}, \phi_{est3}\} \\ Z_{1,2} = \{\psi_s, \theta_s, \phi_s, \psi_s, \theta_s, \phi_s\} \end{cases}$$

Table 2. Model decomposition of the ADCS system into subsystems. $\Sigma_{1,i}$ ($i = 1, 2$).

ADCS system Global Diagnoser	
Max fault isolability	$[f_{vs_x}], [f_{vs_y}], [f_{vs_z}],$
FMSO sets	$[f_{rs_x}], [f_{rs_y}], [f_{rs_z}], [f_{rw_x}], [f_{rw_y}], [f_{rw_z}]$ 2448 FMSO sets

Table 3. FMSO sets for the Global System.

According to the results of Table 3, it can be seen that all faults can be detected and isolated with a centralized diagnoser for the ADCS system with 2448 FMSO sets.

5.2 Decentralized Diagnoser Design

Now, the Algorithm 1 for the decentralized diagnoser design is applied. This algorithm computes two levels ($j = 1, 2$) to achieve the diagnosticability objective, with two subsystems ($i = 1, 2$) for the first level and one subsystem ($i = 1$), for the second level. The design is explained in the following steps:

0.- As a previous step, with the information of Table 2, it is possible to determine the vector of shared variables for $\Sigma_{1,1}$ and $\Sigma_{1,2}$ as:

$$X_{1,1}^s = X_{1,2}^s = \{T_x, T_y, T_z, \psi_{est}, \theta_{est}, \phi_{est}, RW_{am_x}, RW_{am_y}, RW_{am_z}\}, \quad (8)$$

This vector is used to compute the *shared FMSO sets*.

1.- First, *local FMSO sets* are calculated for the subsystem $\Sigma_{1,1}$ of level 1. In $\Sigma_{1,1}$, 3 local FMSO sets are found.

Then, the BILP optimization program selects 2 FMSO sets (between 3 possible sets) that guarantee full diagnosability for the 3 faults: f_{rw_x} , f_{rw_y} and f_{rw_z} with no additional information. Those results are shown in Table 4.

$\Sigma_{1,1}$	
Max fault isolability	$[f_{rw_x}], [f_{rw_y}], [f_{rw_z}]$
Local FMSO sets selected	$\Phi_{1,1}^l = \{\varphi_{11}, \varphi_{12}\}$ $\varphi_{11} = \{e_6, e_9, e_{12}, e_{15}\}$ $\varphi_{12} = \{e_5, e_8, e_{11}, e_{14}\}$

Table 4. Subsystem $\Sigma_{1,1}$: selected local FMSO sets.

2.- No *Local FMSO sets* are found for subsystem $\Sigma_{1,2}$ of level 1. $\Phi_{1,2}^l = \emptyset$

The set of local FMSO sets for $\Sigma_{1,2}$ is empty. Hence, with no additional information, no fault can be diagnosed at level 1 for this subsystem. The conclusion is the following at this stage: if f_{rw_x} , f_{rw_y} or f_{rw_z} occurs, it is detected and isolated at level 1, with no need of further investigation. The 6 remaining faults require to consider the upper level: they are detected at level 1, but need additional information available at a higher level to be isolated.

3.- For subsystems $\Sigma_{1,1}$ and $\Sigma_{1,2}$, shared variables are now assumed to be known and *shared FMSO sets* and *shared CMSO sets* are computed. Results are given in Tables 5 and 6.

$\Sigma_{1,1}$	
Max fault isolability	$[f_{rw_x}], [f_{rw_y}], [f_{rw_z}]$
Shared FMSO sets	$\Phi_{1,1}^s = \{\varphi_4, \varphi_5, \varphi_6, \varphi_7, \varphi_8, \varphi_9\}$ $\varphi_4 = \{e_6, e_{18}\}, \varphi_5 = \{e_5, e_{17}\}$ $\varphi_6 = \{e_5, e_8\}, \varphi_7 = \{e_4, e_{16}\}$ $\varphi_8 = \{e_4, e_7\}, \varphi_9 = \{e_6, e_9\}$
Shared CMSO sets	$\Psi_{1,1}^s = \{\psi_1, \psi_2, \psi_3, \dots, \psi_9\}$ $\psi_1 = \{e_1\}, \psi_2 = \{e_2\}, \psi_3 = \{e_3\}$ $\psi_4 = \{e_6, e_{17}\}, \psi_5 = \{e_8, e_{17}\}$ $\psi_6 = \{e_9, e_{18}\}, \psi_7 = \{e_{10}, e_{13}\}$ $\psi_8 = \{e_{11}, e_{14}\}, \psi_9 = \{e_{12}, e_{15}\}$

Table 5. Subsystem $\Sigma_{1,1}$: $\Phi_{1,1}^s, \Psi_{1,1}^s$.

$\Sigma_{1,2}$	
Max fault isolability	$[f_{vs_x}], [f_{vs_y}], [f_{vs_z}]$
Shared FMSO sets	$\Phi_{1,2}^s = \{\varphi_{10}, \varphi_{11}, \varphi_{12} \dots, \varphi_{20}\}$ $\varphi_{10} = \{e_{21}, e_{22}, e_{23}, e_{24}, e_{28}, e_{29}, e_{30}\}$...
Shared CMSO sets	$\varphi_{20} = \{e_{19}, e_{20}, e_{21}, e_{22}, e_{28}\}$ $\Psi_{1,2}^s = \{\emptyset\}$

Table 6. Subsystem $\Sigma_{1,2}$: $\Phi_{1,2}^s, \Psi_{1,2}^s$.

4.- Then, according to Algorithm 1, at level 2, the subsystem $\Sigma_{2,1}$ is built because all the faults are not yet isolable: this is the idea of *isolation on request*.

For this purpose, shared FMSO and CMSO sets of the children systems of level 1 are considered together with the additional equations of $\Pi_{2,1}$ to form $\Sigma_{2,1}$ as shown in Equation 9.

$$\Sigma_{2,1} = \{e_1, e_2, \dots, e_{24}, e_{28}, e_{29}, e_{30}\} \cup \{e_{25}, e_{26}, e_{27}\} \quad (9)$$

Local FMSO sets are calculated for the subsystem $\Sigma_{2,1}$ at level 2. With the information received, 2448 local FMSO sets are calculated at this stage. Then, the BILP optimization program selects 3 FMSO sets that guarantee isolation of the 6 remaining faults: $[f_{vs_x}], [f_{vs_y}], [f_{vs_z}], [f_{rs_x}], [f_{rs_y}]$ and $[f_{rs_z}]$ as given in Table 7²

² The number of FMSOs computed at this level is the same as the number of FMSOs calculated with the centralized approach because in this case study, full isolation requires to aggregate all the subsystems. This is not a problem because these computations are performed offline. Only 3 of these FMSO are then selected to be implemented online.

	$\Sigma_{2,1}$
Max fault isolability	$[f_{rs_x}], [f_{rs_y}], [f_{rs_z}], [f_{vs_x}], [f_{vs_y}], [f_{vs_z}]$
Local FMSO sets selected	$\Phi_{2,1}^L = \{\varphi_{211}, \varphi_{212}, \varphi_{213}\}$ $\varphi_{211} = \{e_{24}, e_{27}, e_{30}\}$ $\varphi_{212} = \{e_{23}, e_{26}, e_{29}\}$ $\varphi_{213} = \{e_3, e_4, e_5, e_9\}$

Table 7. Subsystem $\Sigma_{2,1}$: selected local FMSO sets.

5.- Based on the results obtained using Algorithm 1, 2 local ARRs for subsystem $\Sigma_{1,1}$ are enough to isolate f_{rw_z} , f_{rw_y} and f_{rw_x} . Then, the 3 ARRs computed from the local FMSO sets selected of $\Sigma_{2,1}$ can complete the isolation for the faults of the ADS $f_{vs_x}, f_{vs_y}, f_{vs_z}, f_{rs_x}, f_{rs_y}$ and f_{rs_z} , as shown in Table 8.

	Faults								
	f_{rw_z}	f_{rw_y}	f_{rw_x}	f_{vs_x}	f_{vs_y}	f_{vs_z}	f_{rs_x}	f_{rs_y}	f_{rs_z}
$arr_1 \in ARR_{1,1}$	X								
$arr_2 \in ARR_{1,1}$		X							
$arr_4 \in ARR_{2,1}$						X			X
$arr_5 \in ARR_{2,1}$				X			X		
$arr_6 \in ARR_{2,1}$			X	X					X

Table 8. detection capability for ARRs issued from the decentralized diagnoser for the ADCS system.

6. CONCLUSION

This paper proposes a design algorithm for decentralized fault diagnosers for systems that have constraints of confidentiality, distance or limited access to some information. The algorithm uses the notion of inter-level communication and optimal selection using a BILP program for each subsystem at each level. The algorithm computes recursively, by developing the just-needed levels, all the analytical residual generators that guaranty to isolate all the faults. Despite the fact that this algorithm does not guarantee that the number of FMSO sets selected are a global minimum, it guarantees maximal fault isolability considering information restrictions at each level. The decentralized diagnoser design has been tested for a real case study of Low Earth Satellite. The advantage of the decentralized architectures comes with the possibility of developing the local diagnosers following the traditional function by function design organization, the fact that the subsystem models do not need to be exposed and the isolation on request property.

7. ACKNOWLEDGMENTS

We want to thank Asma Gasmi for the implementation of the BILP program. This work was funded by the Dirección de Gestión de la Investigación at the PUCP, Lima-Perú through grant DGI-2015-3-0024/195.

REFERENCES

Blanke, M., Kinnaert, M., Lunze, J., and Staroswiecki, M. (2006). *Diagnosis and Fault-Tolerant Control*. Springer-Verlag Berlin Heidelberg.

Chanthery, E., Travé-Massuyès, L., and Indra, S. (2016). Fault isolation on request based on decentralized residual generation. *IEEE Trans. on Sys., Man, and Cybernetics: Systems*, vol. 46(5).

Cordier, M.O. and Grastien, A. (2007). Exploiting independence in a decentralised and incremental approach of diagnosis. In *20th International Joint Conference on Artificial Intelligence*, pp. 292-297.

Debouk, R., Lafortune, S., and Teneketzis, D. (2000). Coordinated decentralized protocols for failure diagnosis of discrete event systems. *Discrete Event Dynamic Systems*, vol. 10(1), pp. 33-86.

Ferdowsi, H., Raja, D., and Jagannathan, S. (2012). A decentralized fault detection and prediction scheme for nonlinear interconnected continuous-time systems. *WCCI 2012 IEEE World Congress on Computational Intelligence*, pp. 1-7.

Krysander, M., Aslund, J., and Frisk, E. (2010a). A structural algorithm for finding testable sub-models and multiple fault isolability analysis. In *21st International Workshop on the Principles of Diagnosis*.

Krysander, M., Heintz, F., Roll, J., and Frisk, E. (2010b). FlexDx: A reconfigurable diagnosis framework. *Engineering applications of artificial intelligence*, 23(8), 1303-1313.

Niemann, T.L.M.B.H. (2003). Structural analysis-a case study of the romer satellite. *Proc. Fault Detect. Supervision Safety Tech. Processes Symp. (SAFEPROCESS) vol. 36(5)*, pp. 185-190.

Pencolé, Y. and Cordier, M.O. (2005). A formal framework for the decentralised diagnosis of large scale discrete event systems and its application to telecommunication networks. *Artificial Intel.*, vol. 164(1-2) pp. 121-170.

Pérez, C.G., Chanthery, E., Travé-Massuyès, L., and Sotomayor, J. (2016). Fault driven minimal structurally overdetermined set in a distributed context. *27th International Workshop on Principles of Diagnosis DX2016*.

Pérez, C.G., Travé-Massuyès, L., Chanthery, E., and Sotomayor, J. (2015). Decentralized diagnosis in a spacecraft attitude determination and control system. *Journal of Physics: Conf Series*, vol. 659(1) pp. 1-12.

Pirmoradi, F., Sassani, F., and de Silva, C. (2009). Fault detection and diagnosis in a spacecraft attitude determination system. *Acta Astronaut.*, vol. 65 pp. 710-729.

Sierksma, G. and Zwols, Y. (2015). *Linear and Integer Optimization: Theory and Practice, Third Edition*. CRC Press.

Siljak, D.D. (2011). *Decentralized Control of Complex Systems*. Dover Publications.

Vanderbei, R.J. (2001). *Linear Programming: Foundations and Extensions*. Springer US.

Wang, H., Liu, W., Qiu, J., and Liu, P.X. (2017). Adaptive fuzzy decentralized control for a class of strong interconnected nonlinear systems with unmodeled dynamics. *IEEE Trans. on Fuzzy Systems*, vol. PP(99), pp. 1-1.

Wang, Y., Yoo, T., and Lafortune, S. (2007). Diagnosis of discrete event systems using decentralized architectures. *Discrete Event Dynamic Sys.*, vol. 17(2), pp. 233-263.

Zaytoon, J. and Sayed-Mouchaweh, M. (2012). Discussion on fault diagnosis methods of discrete event systems. *IFAC Proceedings Volumes*, 45(29), 9-12.

Zhang, X. (2010). Decentralized fault detection for a class of large-scale nonlinear uncertain systems. In *American Control Conference*, pp. 5650-5655.

Zuliana, I. and Renuganth, V. (2010). A study of reaction wheel configurations for a 3-axis satellite attitude control. *Adv. Space Res.* vol. 45(6), pp. 750-759.