



**HAL**  
open science

## **Bond graph/Digraph matching procedure and symbolic determination of state space descriptor systems**

Julien Lagnier, Wilfrid Marquis-Favre, Daniel Thomasset, Didier Remond

### ► **To cite this version:**

Julien Lagnier, Wilfrid Marquis-Favre, Daniel Thomasset, Didier Remond. Bond graph/Digraph matching procedure and symbolic determination of state space descriptor systems. ICBGM, Jul 2018, Bordeaux, France. hal-01870111

**HAL Id: hal-01870111**

**<https://hal.science/hal-01870111v1>**

Submitted on 6 May 2019

**HAL** is a multi-disciplinary open access archive for the deposit and dissemination of scientific research documents, whether they are published or not. The documents may come from teaching and research institutions in France or abroad, or from public or private research centers.

L'archive ouverte pluridisciplinaire **HAL**, est destinée au dépôt et à la diffusion de documents scientifiques de niveau recherche, publiés ou non, émanant des établissements d'enseignement et de recherche français ou étrangers, des laboratoires publics ou privés.

# Bond graph/Digraph matching procedure and symbolic determination of state space descriptor systems

Julien Lagnier  
Engineer, PhD

Siemens PLM Software  
La Cite International  
84 quai Charles de Gaulle  
Lyon, 69006, France  
[julien.lagnier@siemens.com](mailto:julien.lagnier@siemens.com)

Daniel Thomasset  
Professor

Université de Lyon  
Laboratoire Ampère, INSA-Lyon  
20 Avenue Albert Einstein  
Villeurbanne, 69621, France  
[daniel.thomasset@insa-lyon.fr](mailto:daniel.thomasset@insa-lyon.fr)

Wilfrid Marquis-Favre  
Professor

Université de Lyon  
Laboratoire Ampère, INSA-Lyon  
20 Avenue Albert Einstein  
Villeurbanne, 69621, France  
[wilfrid.marquis-favre@insa-lyon.fr](mailto:wilfrid.marquis-favre@insa-lyon.fr)

Didier Rémond  
Professor

Université de Lyon  
LaMCoS, INSA-Lyon  
20 Avenue des Sciences  
Villeurbanne, 69621, France  
[didier.remond@insa-lyon.fr](mailto:didier.remond@insa-lyon.fr)

**Abstract** In the context of structural analysis of descriptor systems (*i.e.*  $\mathbf{E}\dot{\mathbf{x}}(t) = \mathbf{Ax}(t) + \mathbf{Bu}(t)$ , with  $\mathbf{E}$  *singular*, also called *singular systems*, *generalized state space systems*, or *differential-algebraic systems* [1, 2, 3]), this paper proposes an extension of existing procedures to determine the state-space descriptor form from the bond graph model, relaxing simplified assumptions. Using this state-space representation, we also propose to build the exact corresponding digraph of a (bi)causal bond graph. This correspondence is used to rigorously adapt, by means of the digraph tool, the graphical computation of the characteristic polynomial  $\det(s\mathbf{E} - \mathbf{A})$  or the determinant of the *Rosenbrock* matrix  $\det(\mathbf{P}(s))$  directly from the bond graph model (*not presented in this paper*).

**Key words** Structural Analysis, Descriptor Systems, Bicausal Bond Graph, Causal Cycles and Causal Paths, Digraph.

---

ICBGM'2018 (SummerSim 18),  
July 9-12, Bordeaux, France

©2018 Society for Modeling & Simulation International (SCS)

## 1 Introduction

This paper is concerned with the structural analysis of bond graph models, aiming at extending the existing framework on state-space determination, and proposing a procedure that builds the exact corresponding directed-graph (*i.e.* digraph) of a (bi)causal bond graph. This extends the symbolic determination of state space representation procedures on LTI *regular systems* [4, 5, 6, 7, 8] to the class of LTI *descriptor systems* with regular matrix pencil. From the algebraic point of view, such a system can be described by:

$$\Sigma_d : \begin{cases} \mathbf{E}\dot{\mathbf{x}}(t) &= \mathbf{Ax}(t) + \mathbf{Bu}(t) \\ \mathbf{y}(t) &= \mathbf{Cx}(t) + \mathbf{Du}(t) \end{cases} \quad (1)$$

where  $\mathbf{x}(t) \in \mathbb{R}^n$  is the descriptor state vector,  $\mathbf{u}(t) \in \mathbb{R}^m$  the input vector,  $\mathbf{y}(t) \in \mathbb{R}^p$  the output vector and  $\mathbf{E}, \mathbf{A} \in \mathbb{R}^{n \times n}$ ,  $\mathbf{B} \in \mathbb{R}^{n \times m}$ ,  $\mathbf{C} \in \mathbb{R}^{p \times n}$ ,  $\mathbf{D} \in \mathbb{R}^{p \times m}$ , with a regular matrix pencil  $(s\mathbf{E} - \mathbf{A})$ , that is  $\det(s\mathbf{E} - \mathbf{A}) \neq 0$ , and  $s$  the LAPLACE variable.

Descriptor systems have been widely studied in the literature [1, 2, 3] to answer to mechatronic modeling

requirements for representing algebraic constraint equations that may occur in electrical networks [2, 3] or mechanical systems [9], leading to Differential-Algebraic Equations (DAE) with singular matrix  $\mathbf{E}$  in (1). Descriptor systems are also called *singular system*, *generalized state space systems* or *differential algebraic systems* [3]. Structural analysis on linear descriptor systems has been theoretically formalized on digraphs [10], on matroids [11] and on bond graphs [12, 13].

The class of systems targeted in this paper is the one represented by causal or bicausal bond graph models, without necessary integral preferred causality assignment, potentially with zero-order causal paths (*ZCP*) of type *1ZCP*, *2ZCP*, *3ZCP*, *4ZCP* in the classification of [14, 15], and  $\mathbb{R}$  and/or  $\mathbb{I}/\mathbb{C}$  fields. For obvious reasons the only assumption enabling the proposed procedure to be applied is the respect of global causality constraints which guaranty a solvable junction structure (and excludes for instance *ZCP* of class 5). The regularity of the matrix pencil in (1) will be discussed and proven for this class of bond graph models.

The matching proposed in this paper is used to generalize graphical procedures on bond graph from the ones on digraph [4, 5, 13, 16, 17]. In fact, using the digraph and the related frameworks on *regular* [18, 19] and *descriptor* systems [10], this matching enables the characteristic polynomial  $\det(s\mathbf{E} - \mathbf{A})$  or, in the case of square systems ( $m = p$ ), the determinant of the *Rosenbrock* matrix <sup>1</sup>  $\det(\mathbf{P}(s))$  directly from the bond graph model to be determined [21]. These determinants are used for instance to graphically determine the *structure at infinity* of the system [22] or to identify the presence of impulsive modes on power or energy variables [21].

The present paper is organized as follows. Section 2 brings some background on the *junction structure matrix* and proposes some extensions to account for any power-variable of the system. Section 3 proposes to extend the symbolic determination of the state space linear descriptor system from a (bi)causal bond graph model, highlighting an important result about the regularity of its pencil  $s\mathbf{E} - \mathbf{A}$ . Section 4 presents the graphical procedure to obtain a digraph model that exactly matches to the bond graph model, and gives an illustrative example. The conclusion outlines some targeted applications and suggests some directions for future works.

<sup>1</sup> The *Rosenbrock* matrix (also named *system matrix*)  $\mathbf{P}(s) \in \mathbb{R}^{(n+m) \times (n+m)}$  of  $\Sigma_d$  (1) is defined by  $\mathbf{P}(s) = \begin{pmatrix} s\mathbf{E} - \mathbf{A} & \mathbf{B} \\ -\mathbf{C} & \mathbf{D} \end{pmatrix}$  [20]

## 2 Junction Structure Matrix

### 2.1 Original form

The physical and energetical characteristics of the bond graph representation are described in this paper with the *junction structure matrix* approach, originally introduced by ROSENBERG [23, 24]. This approach enables a global consideration of the junction structure of the model and its causal implications on storage elements, dissipative elements, sources and sensors. It suits to the graphical approach of the structural analysis on bond graph. Also it is used in the present paper to determine the state-space equations for the class of bond graph models previously introduced.

From a condensed representation of the junction structure (Figure 1), the storage elements, the dissipation elements, the sources, the sensors, and the *significant* vectors of the causal form, ROSENBERG has established the expression of the outputs of the junction structure in terms of the inputs. This leads to a state-space representation, *regular* (2) or *singular* (1), depending on the topology of the system and the level of equation substitution that could be achieved [23].

$$\Sigma : \begin{cases} \dot{\mathbf{x}}(t) &= \mathbf{A}\mathbf{x}(t) + \mathbf{B}\mathbf{u}(t) \\ \mathbf{y}(t) &= \mathbf{C}\mathbf{x}(t) + \mathbf{D}\mathbf{u}(t) \end{cases} \quad (2)$$

where  $\mathbf{x}(t) \in \mathbb{R}^n$  is the regular state vector,  $\mathbf{u}(t) \in \mathbb{R}^m$  the input vector, and  $\mathbf{y}(t) \in \mathbb{R}^p$  the output vector.

In Figure 1b condensed representation  $\mathbf{x}_I$  and  $\mathbf{x}_D$  are the vectors of energy variables for the storage elements respectively in integral and derivative causality,  $\mathbf{z}_I$  and  $\mathbf{z}_D$ , the associated vectors of co-energy variables, and,  $\mathbf{D}_{in}$  and  $\mathbf{D}_{out}$ , the vector of power variables respectively ingoing and outgoing the dissipative elements. The constitutive laws of the *I*, *C* and *R* fields can be expressed in terms of these vectors:

- with the assumption that the laws are explicit, the storage field can be characterized by

$$\begin{pmatrix} \mathbf{z}_I \\ \mathbf{x}_D \end{pmatrix} = \Phi_S(\mathbf{x}_I, \mathbf{z}_D) \quad (3)$$

Considering, in the present paper, mixed causality with linear laws leads to the following simplification [12]:

$$\begin{pmatrix} \mathbf{z}_I \\ \mathbf{x}_D \end{pmatrix} = \begin{pmatrix} \mathbf{S}_i & \mathbf{S}_{id} \\ \mathbf{S}_{di} & \mathbf{S}_d^{-1} \end{pmatrix} \begin{pmatrix} \mathbf{x}_I \\ \mathbf{z}_D \end{pmatrix} \quad (4)$$

where  $\begin{pmatrix} \mathbf{S}_i & \mathbf{S}_{id} \\ \mathbf{S}_{di} & \mathbf{S}_d^{-1} \end{pmatrix}$  is invertible.

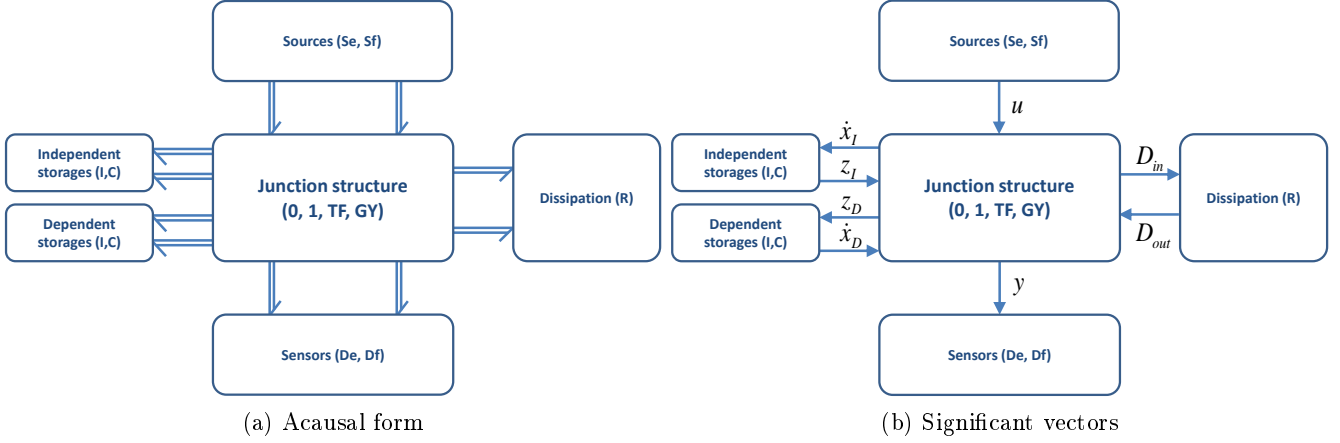

Figure 1: Condensed representation of multiport systems [23]

- the resistive field can be characterized by

$$\mathbf{D}_{out} = \Phi_L(\mathbf{D}_{in}) \quad (5)$$

that can be simplified in the linear case as:

$$\mathbf{D}_{out} = \mathbf{L} \cdot \mathbf{D}_{in} \quad (6)$$

With the assumption that there is no zero-order causal path of class 5 (5ZCP) [14, 15] leading to non solvable junction structure [12] and with explicit constitutive laws, the following linear relation can be written between the outputs  $(\dot{\mathbf{x}}_I^T, \mathbf{z}_D^T, \mathbf{D}_{in}^T)$  of the junction structure and its inputs  $(\mathbf{z}_I^T, \dot{\mathbf{x}}_D^T, \mathbf{D}_{out}^T, \mathbf{u}^T)$ :

$$\begin{pmatrix} \dot{\mathbf{x}}_I \\ \mathbf{z}_D \\ \mathbf{D}_{in} \end{pmatrix} = \begin{pmatrix} \mathbf{S}_{11} & \mathbf{S}_{12} & \mathbf{S}_{13} & \mathbf{S}_{15} \\ \mathbf{S}_{21} & \mathbf{S}_{22} & \mathbf{S}_{23} & \mathbf{S}_{25} \\ \mathbf{S}_{31} & \mathbf{S}_{32} & \mathbf{S}_{33} & \mathbf{S}_{35} \end{pmatrix} \begin{pmatrix} \mathbf{z}_I \\ \dot{\mathbf{x}}_D \\ \mathbf{D}_{out} \\ \mathbf{u} \end{pmatrix} \quad (7)$$

The system (7) includes the underlying condition that the internal causal loops of the junction structure (4ZCP) [14, 15], if exist, are solved. With a more general view, this condition corresponds, on one hand, to the fact that the global KIRCHHOFF constraints on cycles and co-cycles of the junction structure are respected [25], and on the other hand that the *basis order variable of junction structures* is also respected [26]. With the constitutive laws (4) and (6), the equation (7) can be developed under several forms, *e.g. generalized state-space form* [23], *standard implicit form* [12], or *descriptor state-space form* [12, 27, 28, 29], the later one being of interest in this paper.

## 2.2 Extended form

In this section, we propose to extend the output vector of the junction structure with any power variable of the system. The main motivation of this extension is the important simplification of the bond graph inspection, by "breaking" causal loops when extracting the descriptor state-space form from (7).

The related *extended significant vector* is exposed in Figure 2, highlighting the variables  $\mathbf{x}_\lambda$ , that could be components of  $\mathbf{D}_{in}$  and/or  $\mathbf{D}_{out}$  for instance, or any other power variables on a bond in the junction structure. With

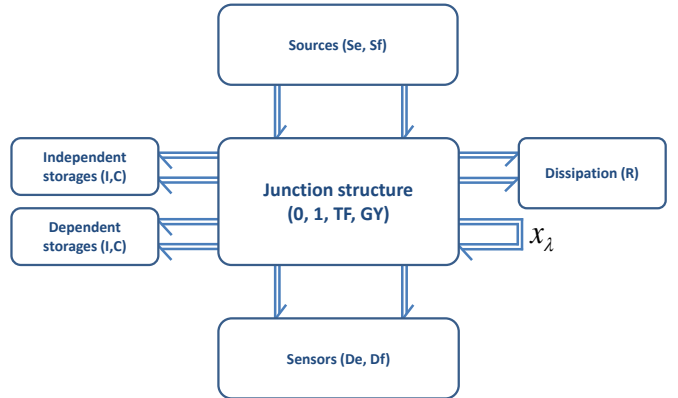

Figure 2: Condensed representation of multiport systems, considering additional power variables of the junction structure

these new variables, the equation (7) becomes :

$$\begin{pmatrix} \dot{\mathbf{x}}_I \\ \mathbf{z}_D \\ \mathbf{D}_{in} \\ \mathbf{x}_\lambda \end{pmatrix} = \begin{pmatrix} \mathbf{S}_{11} & \mathbf{S}_{12} & \mathbf{S}_{13} & \mathbf{S}_{14} & \mathbf{S}_{15} \\ \mathbf{S}_{21} & \mathbf{S}_{22} & \mathbf{S}_{23} & \mathbf{S}_{24} & \mathbf{S}_{25} \\ \mathbf{S}_{31} & \mathbf{S}_{32} & \mathbf{S}_{33} & \mathbf{S}_{34} & \mathbf{S}_{35} \\ \mathbf{S}_{41} & \mathbf{S}_{42} & \mathbf{S}_{43} & \mathbf{S}_{44} & \mathbf{S}_{45} \end{pmatrix} \begin{pmatrix} \mathbf{z}_I \\ \dot{\mathbf{x}}_D \\ \mathbf{D}_{out} \\ \mathbf{x}_\lambda \\ \mathbf{u} \end{pmatrix}$$

$$\mathbf{y} = (\mathbf{S}_{51} \quad \mathbf{S}_{52} \quad \mathbf{S}_{53} \quad \mathbf{S}_{54} \quad \mathbf{S}_{55}) \begin{pmatrix} \mathbf{z}_I \\ \dot{\mathbf{x}}_D \\ \mathbf{D}_{out} \\ \mathbf{x}_\lambda \\ \mathbf{u} \end{pmatrix} \quad (8)$$

One could note that the sub-matrices from (8) are generally not the same as the ones of (7). Furthermore, the differences arise from the non-resolution *a priori* of some causal loops - the ones involving the variables from  $\mathbf{x}_\lambda$  in (8) - which could be 2ZCP, 3ZCP and/or 4ZCP [14, 15], whereas these loops are necessarily solved in (7).

### 3 Symbolic determination of the descriptor state space form

In this section, we propose a LTI descriptor state space form (1) symbolically determined from the bond graph model, using the linear storage field (4) and linear dissipation field (6) laws, together with the extended consideration on input and output relations from the junction structure proposed in (8).

The constitutive laws of dissipation fields (6) enable the outputs from the resistive elements  $D_{out}$  with respect to the other inputs of the junction structure to be expressed,

$$\mathbf{D}_{out} = (\mathbf{I} - \mathbf{L} \mathbf{S}_{33})^{-1} \begin{bmatrix} \mathbf{L} \mathbf{S}_{31} \mathbf{z}_I \\ + \mathbf{L} \mathbf{S}_{32} \dot{\mathbf{x}}_D \\ + \mathbf{L} \mathbf{S}_{34} \mathbf{x}_\lambda \\ + \mathbf{L} \mathbf{S}_{35} \mathbf{u} \end{bmatrix} \quad (9)$$

assuming that the 2ZCP and 3ZCP involving the resistive elements  $R$  are solvable, to insure the invertibility of the matrix  $(\mathbf{I} - \mathbf{L} \mathbf{S}_{33})$ . Then, introducing (9) in (8), we obtain:

$$\begin{pmatrix} \dot{\mathbf{x}}_I \\ \mathbf{z}_D \\ \mathbf{x}_\lambda \end{pmatrix} = \begin{pmatrix} \mathbf{S}_{II} & \mathbf{S}_{ID} & \mathbf{S}_{I\lambda} & \mathbf{S}_{IU} \\ \mathbf{S}_{DI} & \mathbf{S}_{DD} & \mathbf{S}_{D\lambda} & \mathbf{S}_{DU} \\ \mathbf{S}_{\lambda I} & \mathbf{S}_{\lambda D} & \mathbf{S}_{\lambda\lambda} & \mathbf{S}_{\lambda U} \end{pmatrix} \begin{pmatrix} \mathbf{z}_I \\ \dot{\mathbf{x}}_D \\ \mathbf{x}_\lambda \\ \mathbf{u} \end{pmatrix}$$

$$\mathbf{y} = (\mathbf{S}_{YI} \quad \mathbf{S}_{YD} \quad \mathbf{S}_{Y\lambda} \quad \mathbf{S}_{YU}) \begin{pmatrix} \mathbf{z}_I \\ \dot{\mathbf{x}}_D \\ \mathbf{x}_\lambda \\ \mathbf{u} \end{pmatrix} \quad (10)$$

with,

$$\begin{aligned} \mathbf{S}_{II} &= \mathbf{S}_{11} + \mathbf{S}_{13}(\mathbf{I} - \mathbf{L}\mathbf{S}_{33})^{-1}\mathbf{L}\mathbf{S}_{31} \\ \mathbf{S}_{ID} &= \mathbf{S}_{12} + \mathbf{S}_{13}(\mathbf{I} - \mathbf{L}\mathbf{S}_{33})^{-1}\mathbf{L}\mathbf{S}_{32} \\ \mathbf{S}_{I\lambda} &= \mathbf{S}_{14} + \mathbf{S}_{13}(\mathbf{I} - \mathbf{L}\mathbf{S}_{33})^{-1}\mathbf{L}\mathbf{S}_{34} \\ \mathbf{S}_{DI} &= \mathbf{S}_{21} + \mathbf{S}_{23}(\mathbf{I} - \mathbf{L}\mathbf{S}_{33})^{-1}\mathbf{L}\mathbf{S}_{31} \\ \mathbf{S}_{DD} &= \mathbf{S}_{22} + \mathbf{S}_{23}(\mathbf{I} - \mathbf{L}\mathbf{S}_{33})^{-1}\mathbf{L}\mathbf{S}_{32} \\ \mathbf{S}_{D\lambda} &= \mathbf{S}_{24} + \mathbf{S}_{23}(\mathbf{I} - \mathbf{L}\mathbf{S}_{33})^{-1}\mathbf{L}\mathbf{S}_{34} \\ \mathbf{S}_{\lambda I} &= \mathbf{S}_{41} + \mathbf{S}_{43}(\mathbf{I} - \mathbf{L}\mathbf{S}_{33})^{-1}\mathbf{L}\mathbf{S}_{31} \\ \mathbf{S}_{\lambda D} &= \mathbf{S}_{42} + \mathbf{S}_{43}(\mathbf{I} - \mathbf{L}\mathbf{S}_{33})^{-1}\mathbf{L}\mathbf{S}_{32} \\ \mathbf{S}_{\lambda\lambda} &= \mathbf{S}_{44} + \mathbf{S}_{43}(\mathbf{I} - \mathbf{L}\mathbf{S}_{33})^{-1}\mathbf{L}\mathbf{S}_{34} \\ \mathbf{S}_{IU} &= \mathbf{S}_{15} + \mathbf{S}_{13}(\mathbf{I} - \mathbf{L}\mathbf{S}_{33})^{-1}\mathbf{L}\mathbf{S}_{35} \\ \mathbf{S}_{DU} &= \mathbf{S}_{25} + \mathbf{S}_{23}(\mathbf{I} - \mathbf{L}\mathbf{S}_{33})^{-1}\mathbf{L}\mathbf{S}_{35} \\ \mathbf{S}_{\lambda U} &= \mathbf{S}_{45} + \mathbf{S}_{43}(\mathbf{I} - \mathbf{L}\mathbf{S}_{33})^{-1}\mathbf{L}\mathbf{S}_{35} \end{aligned} \quad (11)$$

$$\begin{aligned} \mathbf{S}_{YI} &= \mathbf{S}_{51} + \mathbf{S}_{53}(\mathbf{I} - \mathbf{L}\mathbf{S}_{33})^{-1}\mathbf{L}\mathbf{S}_{31} \\ \mathbf{S}_{YD} &= \mathbf{S}_{52} + \mathbf{S}_{53}(\mathbf{I} - \mathbf{L}\mathbf{S}_{33})^{-1}\mathbf{L}\mathbf{S}_{32} \\ \mathbf{S}_{Y\lambda} &= \mathbf{S}_{54} + \mathbf{S}_{53}(\mathbf{I} - \mathbf{L}\mathbf{S}_{33})^{-1}\mathbf{L}\mathbf{S}_{34} \\ \mathbf{S}_{YU} &= \mathbf{S}_{55} + \mathbf{S}_{53}(\mathbf{I} - \mathbf{L}\mathbf{S}_{33})^{-1}\mathbf{L}\mathbf{S}_{35} \end{aligned}$$

Using the constitutive laws of storage fields (4), the equation (10) can be re-written in terms of energy variables  $\mathbf{x}_I$  and  $\mathbf{x}_D$ , power variables  $\mathbf{x}_\lambda$ , and in term of the output vector  $\mathbf{y}$ . In a first step, the variable  $\mathbf{z}_D$  are expressed as,

$$\mathbf{z}_D = (\mathbf{I} - \mathbf{S}_{DI}\mathbf{S}_{id})^{-1} \begin{bmatrix} \mathbf{S}_{DI}\mathbf{S}_i\mathbf{x}_I \\ + \mathbf{S}_{DD}\dot{\mathbf{x}}_D \\ + \mathbf{S}_{D\lambda}\mathbf{x}_\lambda \\ + \mathbf{S}_{DU}\mathbf{u} \end{bmatrix} \quad (12)$$

Then, using (12), the equation (10) can be put on the LTI descriptor state space form (1) as follows:

$$\begin{pmatrix} \mathbf{I}_I & \mathbf{E}_{ID} & \mathbf{0} \\ \mathbf{0} & \mathbf{E}_D & \mathbf{0} \\ \mathbf{0} & \mathbf{E}_{\lambda D} & \mathbf{0} \end{pmatrix} \begin{pmatrix} \dot{\mathbf{x}}_I \\ \dot{\mathbf{x}}_D \\ \dot{\mathbf{x}}_\lambda \end{pmatrix} =$$

$$\begin{pmatrix} \mathbf{A}_I & \mathbf{0} & \mathbf{A}_{I\lambda} \\ \mathbf{A}_{DI} & \mathbf{I}_D & \mathbf{A}_{D\lambda} \\ \mathbf{A}_{\lambda I} & \mathbf{0} & \mathbf{I}_\lambda + \mathbf{A}_\lambda \end{pmatrix} \begin{pmatrix} \mathbf{x}_I \\ \mathbf{x}_D \\ \mathbf{x}_\lambda \end{pmatrix} + \begin{pmatrix} \mathbf{B}_I \\ \mathbf{B}_D \\ \mathbf{B}_\lambda \end{pmatrix} \mathbf{u}$$

$$\mathbf{y} = \left( \mathbf{C}_I \quad \mathbf{C}_D \frac{d(\cdot)}{dt} \quad \mathbf{C}_\lambda \right) \begin{pmatrix} \mathbf{x}_I \\ \mathbf{x}_D \\ \mathbf{x}_\lambda \end{pmatrix} + (\mathbf{D}) \mathbf{u} \quad (13)$$

with  $\mathbf{H}_D = (\mathbf{I} - \mathbf{S}_{DI}\mathbf{S}_{id})^{-1}$ , and

$$\begin{aligned}
\mathbf{E}_{ID} &= -[\mathbf{S}_{ID} + \mathbf{S}_{II}\mathbf{S}_{id}\mathbf{H}_D\mathbf{S}_{DD}] \\
\mathbf{E}_D &= [\mathbf{S}_d^{-1}\mathbf{H}_D\mathbf{S}_{DD}] \\
\mathbf{E}_{\lambda D} &= [\mathbf{S}_{\lambda D} + \mathbf{S}_{\lambda I}\mathbf{S}_{id}\mathbf{H}_D\mathbf{S}_{DD}] \\
\mathbf{A}_I &= [\mathbf{S}_{II}\mathbf{S}_i + \mathbf{S}_{II}\mathbf{S}_{id}\mathbf{H}_D\mathbf{S}_{DI}\mathbf{S}_i] \\
\mathbf{A}_{I\lambda} &= [\mathbf{S}_{I\lambda} + \mathbf{S}_{II}\mathbf{S}_{id}\mathbf{H}_D\mathbf{S}_{D\lambda}] \\
\mathbf{A}_{DI} &= -[\mathbf{S}_{di} + \mathbf{S}_d^{-1}\mathbf{H}_D\mathbf{S}_{DI}\mathbf{S}_i] \\
\mathbf{A}_{D\lambda} &= -[\mathbf{S}_d^{-1}\mathbf{H}_D\mathbf{S}_{D\lambda}] \\
\mathbf{A}_{\lambda I} &= -[\mathbf{S}_{\lambda I}\mathbf{S}_i + \mathbf{S}_{\lambda I}\mathbf{S}_{id}\mathbf{H}_D\mathbf{S}_{DI}\mathbf{S}_i] \\
\mathbf{A}_\lambda &= -[\mathbf{S}_{\lambda\lambda} + \mathbf{S}_{\lambda I}\mathbf{S}_{id}\mathbf{H}_D\mathbf{S}_{D\lambda}] \\
\mathbf{B}_I &= [\mathbf{S}_{IU} + \mathbf{S}_{II}\mathbf{S}_{id}\mathbf{H}_D\mathbf{S}_{DU}] \\
\mathbf{B}_D &= -[\mathbf{S}_d^{-1}\mathbf{H}_D\mathbf{S}_{DU}] \\
\mathbf{B}_\lambda &= -[\mathbf{S}_{\lambda U} + \mathbf{S}_{\lambda I}\mathbf{S}_{id}\mathbf{H}_D\mathbf{S}_{DU}] \\
\mathbf{C}_I &= [\mathbf{S}_{YI}\mathbf{S}_i + \mathbf{S}_{YI}\mathbf{S}_{id}\mathbf{H}_D\mathbf{S}_{DI}\mathbf{S}_i] \\
\mathbf{C}_D &= [\mathbf{S}_{YD} + \mathbf{S}_{YI}\mathbf{S}_{id}\mathbf{H}_D\mathbf{S}_{DD}] \\
\mathbf{C}_\lambda &= [\mathbf{S}_{Y\lambda} + \mathbf{S}_{YI}\mathbf{S}_{id}\mathbf{H}_D\mathbf{S}_{D\lambda}] \\
\mathbf{D} &= [\mathbf{S}_{YU} + \mathbf{S}_{YI}\mathbf{S}_{id}\mathbf{H}_D\mathbf{S}_{DU}]
\end{aligned} \tag{14}$$

The LTI state-space form (13) is thus generic to any causal or bicausal bond graph model with linear constitutive laws, where the only assumption is that the junction structure is solvable. The bond graph model can have fields (of type  $I$ ,  $C$ ,  $IC$  and/or  $R$ ), zero-order causal paths of type  $1ZCP$ ,  $2ZCP$ ,  $3ZCP$ ,  $4ZCP$  [14, 15], and integral, derivative or mixed preferred causality assignment. An important result is that the pencil  $(\mathbf{E}, \mathbf{A})$  of (13) is regular, as we structurally have  $\det(s\mathbf{E} - \mathbf{A}) \neq 0$  in (13). This justifies the restriction of the algebraic framework to this class of systems in this paper (equation (1)), and also ensures the existence and the unicity of a solution [2]. It can be underlined that the form (13) is consistent with the several simplified forms previously mentioned [7, 12, 13, 17, 28, 29, 30], and thus proposes a generic and common framework to these simplified cases.

The form (13) will be used in section 4 to develop the procedure to build the matching digraph of a bond graph model (proposition 1).

## 4 Bond graph/Digraph matching

In the present paper, the directed-graph (digraph) characterization of square matrices is understood as the Cauchy-Coates representation [10, 18, 19]<sup>2</sup>. In the sequel, considering the digraph representation of the ma-

<sup>2</sup>The definitions of the several digraph notions used in this section can be found in [10].

trix pencil  $s\mathbf{E} - \mathbf{A}$  of (13), an edge between two vertices related to the matrix  $\mathbf{E}$  (resp.  $\mathbf{A}$ ) is called an **E-edge** (resp. **A-edge**). By extension, considering the complete digraph of the system (13), an edge with (resp. without) a LAPLACE operator is called an **E-edge** (resp. **A-edge**).

### 4.1 Generic digraph construction from a bond graph model

#### 4.1.1 Procedure

**Proposition 1.** *Considering the (bi)causal bond graph model representation of LTI descriptor system (13), the matching digraph - represented in Figure 3 - is obtained from the following steps:*

1. Each energy variable related to a storage element with integral causality, each energy variable related to a storage element with derivative causality, each power variable chosen in the state vector, each input variable related to a flow or effort source and each output variable related to a flow or effort sensor is respectively represented by a state vertex  $x_{I_i}$ ,  $x_{D_i}$  and  $x_{\lambda_i}$ , input vertex  $u_i$  and output vertex  $y_i$  on the digraph.
2. Submatrix  $\mathbf{I}_I$ : for each state vertex  $x_{I_i}$  of the digraph is associated a unitary cycle of type **E-edge**, with a unitary weight.
3. Submatrix  $\mathbf{E}_{ID}$ : on the bond graph, each causal path between the derivative of an energy variable  $x_{D_i}$  and the derivative of an energy variable  $x_{I_j}$  is represented on the digraph by an **E-edge** between the state vertex  $x_{D_i}$  and the state vertex  $x_{I_j}$ , with a weight  $\mathbf{e}_{ID_{ji}}$  equal to the opposite of the static gain of the causal path.
4. Submatrix  $\mathbf{E}_D$ : each causal path between the derivative of an energy variable  $x_{D_i}$  and an energy variable  $x_{D_j}$  is represented on the digraph by an **E-edge** between the state vertex  $x_{D_i}$  and the state vertex  $x_{D_j}$ , with a weight  $\mathbf{e}_{D_{ji}}$  equal to the static gain of the causal path.
5. Submatrix  $\mathbf{E}_{\lambda D}$ : each causal path between the derivative of an energy variable  $x_{D_i}$  and a power variable  $x_{\lambda_j}$  is represented on the digraph by an **E-edge** between the state vertex  $x_{D_i}$  and the state vertex  $x_{\lambda_j}$ , with a weight  $\mathbf{e}_{\lambda D_{ji}}$  equal to the static gain of the causal path.
6. Submatrix  $\mathbf{A}_I$ : each causal path between an energy variable  $x_{I_i}$  and the derivative of an energy variable

$x_{I_j}$  is represented on the digraph by an **A-edge** between the state vertex  $x_{I_i}$  and the state vertex  $x_{I_j}$ , with a weight  $\mathbf{a}_{I_j i}$  equal to the static gain of the causal path.

7. Submatrix  $\mathbf{A}_{I\lambda}$ : each causal path between a power variable  $x_{\lambda_i}$  and the derivative of an energy variable  $x_{I_j}$  is represented on the digraph by an **A-edge** between the state vertex  $x_{\lambda_i}$  and the state vertex  $x_{I_j}$ , with a weight  $\mathbf{a}_{I\lambda_j i}$  equal to the static gain of the causal path.
8. Submatrix  $\mathbf{A}_{DI}$ : each causal path between an energy variable  $x_{I_i}$  and an energy variable  $x_{D_j}$  is represented on the digraph by an **A-edge** between the state vertex  $x_{I_i}$  and the state vertex  $x_{D_j}$ , with a weight  $\mathbf{a}_{DI_j i}$  equal to the opposite of the static gain of the causal path.
9. Submatrix  $\mathbf{I}_D$ : to each state vertex  $x_{D_i}$  of the digraph is associated a unitary cycle of type **A-edge**, with a unitary weight.
10. Submatrix  $\mathbf{A}_{D\lambda}$ : each causal path between a power variable  $x_{\lambda_i}$  and the derivative of an energy variable  $x_{D_j}$  is represented on the digraph by an **A-edge** between the state vertex  $x_{\lambda_i}$  and the state vertex  $x_{D_j}$ , with a weight  $\mathbf{a}_{D\lambda_j i}$  equal to the opposite of the static gain of the causal path.
11. Submatrix  $\mathbf{A}_{\lambda I}$ : each causal path between an energy variable  $x_{I_i}$  and a power variable  $x_{\lambda_j}$  is represented on the digraph by an **A-edge** between the state vertex  $x_{I_i}$  and the state vertex  $x_{\lambda_j}$ , with a weight  $\mathbf{a}_{\lambda I_j i}$  equal to the opposite of the static gain of the causal path.
12. Submatrix  $\mathbf{I}_\lambda$ : to each state vertex  $x_{\lambda_i}$  of the digraph is associated a unitary cycle of type **A-edge**, with a unitary weight.
13. Submatrix  $\mathbf{A}_\lambda$ : each causal path between a power variable  $x_{\lambda_i}$  and a power variable  $x_{\lambda_j}$  is represented on the digraph by an **A-edge** between the state vertex  $x_{\lambda_i}$  and the state vertex  $x_{\lambda_j}$ , with a weight  $\mathbf{a}_{\lambda_j i}$  equal to the opposite of the static gain of the causal path.

The rules 1 to 13 stand for the construction of the digraph corresponding to the pencil  $\mathbf{sE} - \mathbf{A}$ , which enables the graphical determination of the characteristic polynomial of the descriptor system (13), proposed in [10]. In order to compute the determinant of the Rosenbrock matrix  $\mathbf{P}(s)$ , the digraph has to be completed with the following steps 14 to 21:

14. Submatrix  $\mathbf{B}_I$ : each causal path between an input variable  $u_i$  and the derivative of an energy variable  $x_{I_j}$  is represented on the digraph by an **A-edge** between the input vertex  $u_i$  and the state vertex  $x_{I_j}$ , with a weight  $\mathbf{b}_{I_j i}$  equal to the static gain of the causal path.
15. Submatrix  $\mathbf{B}_D$ : each causal path between an input variable  $u_i$  and an energy variable  $x_{D_j}$  is represented on the digraph by an **A-edge** between the input vertex  $u_i$  and the state vertex  $x_{D_j}$ , with a weight  $\mathbf{b}_{D_j i}$  equal to the opposite of the static gain of the causal path.
16. Submatrix  $\mathbf{B}_\lambda$ : each causal path between an input variable  $u_i$  and a power variable  $x_{\lambda_j}$  is represented on the digraph by an **A-edge** between the input vertex  $u_i$  and the state vertex  $x_{\lambda_j}$ , with a weight  $\mathbf{b}_{\lambda_j i}$  equal to the opposite of the static gain of the causal path.
17. Submatrix  $\mathbf{C}_I$ : each causal path between an energy variable  $x_{I_i}$  and an output variable  $y_j$  is represented on the digraph by an **A-edge** between the state vertex  $x_{I_i}$  and the output vertex  $y_j$ , with a weight  $\mathbf{C}_{I_j i}$  equal to the static gain of the causal path.
18. Submatrix  $\mathbf{C}_D$ : each causal path between the derivative of an energy variable  $x_{D_i}$  and an output variable  $y_j$  is represented on the digraph by an **E-edge** between the state vertex  $x_{D_i}$  and the output vertex  $y_j$ , with a weight  $\mathbf{c}_{D_j i}$  equal to the static gain of the causal path.
19. Submatrix  $\mathbf{C}_\lambda$ : each causal path between a power variable  $x_{\lambda_i}$  and an output variable  $y_j$  is represented on the digraph by an **A-edge** between the state vertex  $x_{\lambda_i}$  and the output vertex  $y_j$ , with a weight  $\mathbf{c}_{\lambda_j i}$  equal to the static gain of the causal path.
20. Submatrix  $\mathbf{D}$ : each causal path between an input variable  $u_i$  and an output variable  $y_j$  is represented on the digraph by an **A-edge** between the input vertex  $u_i$  and the output vertex  $y_j$ , with a weight  $\mathbf{d}_{j i}$  equal to the static gain of the causal path.

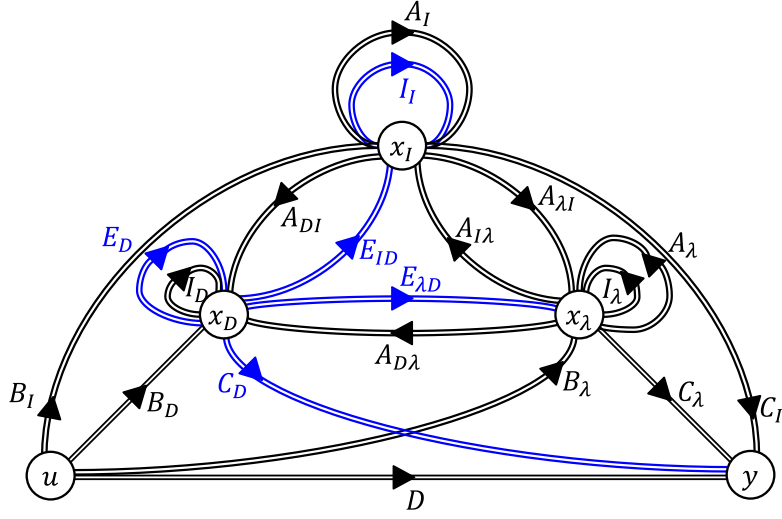

Figure 3: Generic digraph matching to a bond graph model by applying proposition 1

On the digraph representation of Figure 3 obtained from proposition 1, the following remarks can be highlighted:

- the edges of type  $E$  are:
  - either loops on the energy variable  $x_{I_i}$  vertices,
  - or the edges out-going from the energy variable  $x_{D_i}$  vertices,
- the edge of type  $A$  are all the other edges.

#### 4.1.2 Example

We consider the model of Figure 4, specifying a flow source and an effort sensor. According to (13), the state-space representation is given in (15).

$$\begin{bmatrix} 1 & 0 & 1 \\ 0 & 1 & -1 \\ 0 & 0 & 0 \end{bmatrix} \begin{bmatrix} \dot{p}_{I_1} \\ \dot{p}_{I_2} \\ \dot{p}_D \end{bmatrix} = \begin{bmatrix} 0 & 0 & 0 \\ 0 & 0 & 0 \\ -\frac{I_d}{I_1} & \frac{I_d}{I_2} & 1 \end{bmatrix} \begin{bmatrix} p_{I_1} \\ p_{I_2} \\ p_D \end{bmatrix} + \begin{bmatrix} 0 \\ 0 \\ -I_d \end{bmatrix} u$$

$$y = \begin{bmatrix} 0 & 0 & \frac{d(\cdot)}{dt} \end{bmatrix} \begin{bmatrix} p_{I_1} \\ p_{I_2} \\ p_D \end{bmatrix} + [0] u \quad (15)$$

The corresponding digraph obtained with proposition 1 is given in Figure 5.

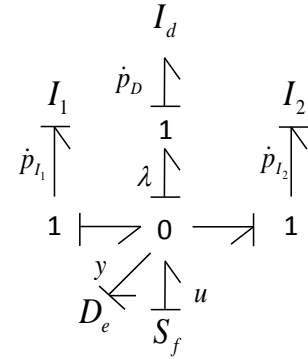

Figure 4: Bond graph example with energy storage element in derivative causality

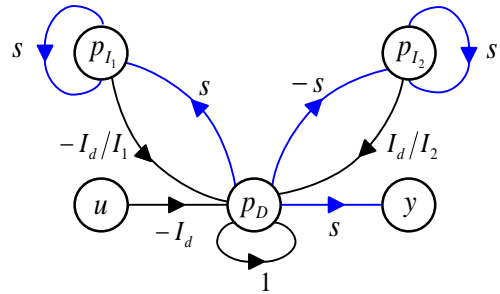

Figure 5: Corresponding digraph model of Figure 4 model from proposition 1



If we augment the state vector in (15) with the power variable  $\lambda$  specified in Figure 4 and according to (13), the equation system can be written as (16), equivalent to (15).

$$\begin{bmatrix} 1 & 0 & 0 & 0 \\ 0 & 1 & 0 & 0 \\ 0 & 0 & 0 & 0 \\ 0 & 0 & 1 & 0 \end{bmatrix} \begin{bmatrix} \dot{p}_{I_1} \\ \dot{p}_{I_2} \\ \dot{p}_D \\ \dot{\lambda} \end{bmatrix} = \begin{bmatrix} 0 & 0 & 0 & -1 \\ 0 & 0 & 0 & 1 \\ -\frac{I_d}{I_1} & \frac{I_d}{I_2} & 1 & 0 \\ 0 & 0 & 0 & 1 \end{bmatrix} \begin{bmatrix} p_{I_1} \\ p_{I_2} \\ p_D \\ \lambda \end{bmatrix} + \begin{bmatrix} 0 \\ 0 \\ -I_d \\ 0 \end{bmatrix} u$$

$$y = [0 \ 0 \ 0 \ 1] \begin{bmatrix} p_{I_1} \\ p_{I_2} \\ p_D \\ \lambda \end{bmatrix} + [0] u \quad (16)$$

The corresponding digraph obtained with proposition 1 is given in Figure 6.

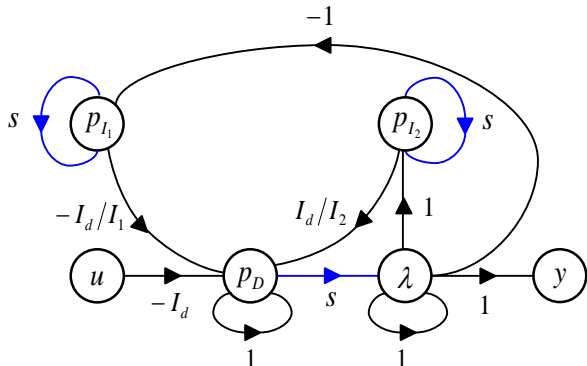

Figure 6: Corresponding digraph model of Figure 4 bond graph with the additional state variable  $\lambda$

**Remark :** for the sake of clarity, Figure 6 digraph shows the  $E$ -edges with the LAPLACE operator in their respective weights, to clearly highlight these edges.

#### 4.1.3 Consideration of zero-order causal cycles

The digraph corresponding to a bond graph model requires the determination of the static gains of the causal paths, which potentially can be generalized<sup>3</sup>, depending

<sup>3</sup>*i.e.* in the sequence of the constitutive variables of the path, some variables (flow or effort) can appear more than once [16].

on the state variables chosen in (13) (*i.e.* with or without power variables  $\mathbf{x}_\lambda$  in addition of the energy variables  $\mathbf{x}_I$  and  $\mathbf{x}_D$ ). First, the presence of all the energy variables (*i.e.* dependant and independant) in the state vector means that all 1ZCP and 3ZCP involving  $I$  and/or  $C$  elements are not solved *a priori*, and are "cut" by the fact of having to explicitly express one of the variables belonging to each of these causal loops. Secondly, the absence of power variables  $\mathbf{x}_\lambda$  in the state vector requires to solve all the "other ZCP", *i.e.* 2ZCP, 3ZCP involving only  $R$  elements, and also 4ZCP. The case of 2ZCP and 3ZCP involving only  $R$  elements is detailed in [31, 32], noticing that structurally in (9),

$$(\mathbf{I} - \mathbf{L}\mathbf{S}_{33})^{-1} = \sum_{l=0}^{\infty} (\mathbf{L}\mathbf{S}_{33})^l \quad (17)$$

This corresponds to a causal loop that is browsed an infinite number of times, without modification of its order. It is also worth noticing that the form (17) leads to the solvability condition of ROSENBERG & ANDRY [33], to ensure the convergence of the series.

The important idea of augmenting the state vector with power variables is the potential gain of simplicity when inspecting the bond graph by reducing the number of zero-order causal cycles to be considered to build the state-space formulation (13) as well as the corresponding digraph (proposition 1).

## 4.2 Digraph/bond matching between digraph cycles and bond graph cycles

By definition and construction with the proposition 1, an edge on the digraph corresponds on the bond graph to a causal path between two given variables of the state vector (or their derivatives with respect to time), without any other chosen state variable occurring in this path. Given the fact that a digraph *path* is an oriented sequence of edges such that the initial vertex of each succeeding edge is the final vertex of the preceding edge [10], the corresponding notion in bond graph is a causal path going through the different variables associated with the vertices involved in the digraph oriented path. A digraph *cycle* is a specific oriented *closed path* in which the initial vertex and the final vertex are the same and in which no vertex is reached more than once, except the initial-final vertex. In bond graph, *considering the variables of the state vector*, the digraph cycle corresponds to a *causal cycle* in which a variable associated with a digraph vertex is reached only once. This correspondence is illustrated in Figure 7 on example page 7 from corresponding digraph of Figure 5.

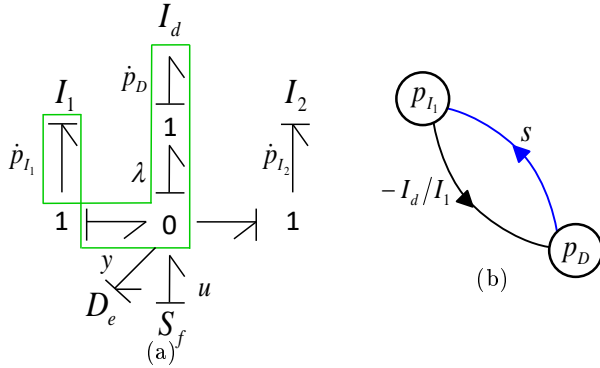

Figure 7: Correspondence between the bond graph cycles (a) and the digraph cycles (b) on page 7 example

## 5 Conclusion

For the class of LTI descriptor systems (1), we have proposed in this paper an extension of the junction structure matrix (section 2.2), adding any power variable of interest, and leading to the proposition of an extended symbolic determination of the descriptor state space system from a (bi)causal bond graph without preferred causality assignment, with potentially zero-order causal paths of type 1ZCP, 2ZCP, 3ZCP, 4ZCP, and R and/or I/C fields (section 3). An important result on the regularity of the matrix pencil  $(s\mathbf{E} - \mathbf{A})$  for this class of system has been highlighted. A bond graph/digraph matching has then been proposed (section 4), with a dedicated digraph construction procedure (proposition 1). This work could be seen as the core material to adapt the existing digraph procedure [10, 19] for the graphical determination of determinants on the bond graph model [22]. Before, this requires a completion of the bond graph/digraph matching introduced in section 4.2 by introducing, first, the notion of supplemented digraph, involving feedback edges from each output to each input [19]. Previous considerations on cycles correspondence can naturally be generalized to the input variables  $u_i$  and output variables  $y_i$  of the system (*i.e.* on one hand, the related vertex in the digraph, and on the other hand, source and sensor elements in the bond graph). The digraph/bond graph matching can then be established between the supplemented digraph *cycles* involving the input and output vertices, and the input/output causal *paths* on the corresponding bond graph, and then completed by the correspondance of *cycle family* on the supplemented digraph and *bond graph family* as defined in [21].

## References

- [1] H. H. Rosenbrock, “Structural properties of linear dynamical systems,” *International Journal of Control*, vol. 20, no. 2, pp. 191–202, 1974.
- [2] G. Verghese, B. Levy, and T. Kailath, “A generalized state-space for singular systems,” *IEEE Transactions on Automatic Control*, vol. 26, pp. 811–831, Aug 1981.
- [3] L. Dai, *Singular Control Systems*. Secaucus, NJ, USA: Springer-Verlag New York, Inc., 1989. 301 pages.
- [4] A. Rahmani, *Etude structurelle des systèmes linéaires par l’approche Bond Graph*. PhD thesis, Université Lille 1, 1993.
- [5] A. Rahmani, C. Sueur, and G. Dauphin-Tanguy, “Approche des bond graphs pour l’analyse structurelle des systèmes linéaires,” *Linear Algebra and its Applications*, vol. 259, no. 0, pp. 101 – 131, 1997.
- [6] R. Fotsu Ngwompo, *Contribution au dimensionnement des systèmes sur des critères dynamiques et énergétiques: approche par bond graph*. PhD thesis, Institut National des Sciences Appliquées (Lyon), 1997.
- [7] A. Rahmani and G. Dauphin-Tanguy, “Symbolic determination of state matrices from bond graph model with derivative causality,” in *IEEE SMC IMACS Multiconference Computation Engineering in System Application*, vol. 1, (Hammamet, Tunisie), pp. 272–277, 1998.
- [8] G. Dauphin-Tanguy, *Les bond graphs*. IC2: Série Systèmes automatisés, Hermes Science Publications, 2000. 383 pages.
- [9] K. Murota, *Systems Analysis by Graphs and Matroids*. Springer-Verlag Berlin Heidelberg, 1987. 284 pages.
- [10] K. J. Reinschke, “Graph-theoretic approach to symbolic analysis of linear descriptor systems,” *Linear Algebra and its Applications*, vol. 197 198, pp. 217 – 244, 1994.
- [11] K. Murota and J. van der Woude, “Structure at infinity of structured descriptor systems and its applications,” *SIAM Journal on Control and Optimization*, vol. 29, no. 4, pp. 878–894, 1991.

- [12] J. Buisson and H. Cormerais, "Descriptor systems for the knowledge modelling and simulation of hybrid physical systems," in *JESA Journal européen des systèmes automatisés*, vol. 32, pp. 1047–1072, march 1998.
- [13] A. Mouhri, A. Rahmani, and G. Dauphin-Tanguy, "Symbolic determination of generalized state equation for singular system modelled by bond graph," *CSCC'99 Proceedings*, pp. 2811–2816, 1999.
- [14] J. van Dijk and P. Breedveld, "Simulation of system models containing zero-order causal paths : I. classification of zero-order causal paths," *Journal of the Franklin Institute*, vol. 328, no. 5-6, pp. 959 – 979, 1991.
- [15] J. van Dijk, *On the role of bond graph causality in modelling mechatronic systems*. PhD thesis, Twente University, Netherlands, 1994.
- [16] A. Jardin, *Contribution à une méthodologie de dimensionnement des systèmes mécatroniques : analyse structurelle et couplage à l'optimisation dynamique*. PhD thesis, Institut National des Sciences Appliquées (Lyon, France), Jan. 2010.
- [17] M. El Feki, *Analyse et synthèse de tolérance pour la conception et le dimensionnement des systèmes mécatroniques*. PhD thesis, Ecole Centrale de Lyon (France), July 2011.
- [18] A. L. Cauchy, *Mémoire sur les fonctions qui ne peuvent obtenir que deux valeurs égales et de signes contraires par suite des transpositions opérées entre les variables qu'elles renferment: lu à l'Institut le 30 Novembre 1812*. Ecole polytechnique (France), 1812.
- [19] K. J. Reinschke, *Multivariable control : a graph-theoretic approach*. Lecture notes in control and information sciences, Berlin, New York: Springer-Verlag, 1988. 236 pages.
- [20] H. H. Rosenbrock, *State-space and multivariable theory*. London: Nelson, 1970.
- [21] J. Lagnier, *Structural analysis of descriptor systems for modeling and design of mechatronic systems*. PhD thesis, Université de Lyon, June 2017.
- [22] J. Lagnier, D. Eberard, M. Di Loreto, D. Rémond, and W. Marquis-Favre, "Definition of essential order on descriptor systems and its bond graph determination," in *Proceedings of the International Conference On Bond Graph Modeling and Simulation (ICBGM 2016)* (J. J. Granda and D. C. Karnopp, eds.), (Montreal, Canada), pp. 133–141, Society for Modeling & Simulation International (SCS), July 24-27 2016.
- [23] R. C. Rosenberg, "State-space formulation for bond graph models of multiport systems," *Journal of Dynamic Systems, Measurement, and Control*, vol. 93, pp. 35–40, Mar. 1971.
- [24] H. M. Paynter, "Discussion: "state-space formulation for bond graph models of multiport systems" (Rosenberg, r. c., 1971, asme j. dyn. syst., meas., control, 93, pp. 35-40)," *Journal of Dynamic Systems, Measurement, and Control*, vol. 93, pp. 123–124, June 1971.
- [25] C. Bidard, *Graphes de liaison torsoriels pour la modélisation et l'analyse cinéstatiques des mécanismes*. PhD thesis, Université Lyon 1, 1994.
- [26] R. C. Rosenberg and B. Moultrie, "Basis order for bond graph junction structures," *IEEE Transactions on Circuits and Systems*, vol. CAS-27, pp. 909–920, October 1980.
- [27] W. Minten, B. D. Moor, and J. Vandewalle, "State equations of nonlinear dynamic systems," in *International Conference on Bond Graph Modeling, ICBGM'95, Proceeding of the 1995 Western Simulation Multiconference*, January 15-18 1995.
- [28] A. Mouhri, *Etude structurelle des systèmes généralisés par l'approche bond graph*. PhD thesis, Université Lille 1, 2000. Th. : productique.
- [29] A. Rahmani and G. Dauphin-Tanguy, "Structural analysis of switching systems modelled by bond graph," *Mathematical and Computer Modelling of Dynamical Systems*, vol. 12, no. 2-3, pp. 235–247, 2006.
- [30] J. Buisson and H. Cormerais, "Modeling hybrid systems with bond-graph using an implicit formulation," *The Bond Graph Digest*, vol. 1, 1997.
- [31] B. M. Maschke, "A transformation from bond-graphs to system-graphs," *Proceedings ASME Winter Annual Meeting*, vol. Vol.8, pp. pp.23–32, 1988.
- [32] B. M. Maschke, *Contribution à une approche par bond-graph de l'étude et la conception de lois de commande de robots contenant des segments flexibles*. PhD thesis, Université Paris 11, 1990.
- [33] R. Rosenberg and A. Andry, "Solvability of bond graph junction structures with loops," *IEEE Transactions on Circuits and Systems*, vol. 26, pp. 130–137, Feb 1979.