



HAL
open science

INES: an innovative and flexible system for in-flight radiation measurements in the presence of ablation

Gilles Bailet, Alexis Bourgoing, Thierry Magin, Christophe O. Laux

► To cite this version:

Gilles Bailet, Alexis Bourgoing, Thierry Magin, Christophe O. Laux. INES: an innovative and flexible system for in-flight radiation measurements in the presence of ablation. IPPW2017, Jun 2017, La Hague, Netherlands. hal-01866560

HAL Id: hal-01866560

<https://hal.science/hal-01866560>

Submitted on 4 Apr 2019

HAL is a multi-disciplinary open access archive for the deposit and dissemination of scientific research documents, whether they are published or not. The documents may come from teaching and research institutions in France or abroad, or from public or private research centers.

L'archive ouverte pluridisciplinaire **HAL**, est destinée au dépôt et à la diffusion de documents scientifiques de niveau recherche, publiés ou non, émanant des établissements d'enseignement et de recherche français ou étrangers, des laboratoires publics ou privés.



Distributed under a Creative Commons Attribution - NonCommercial 4.0 International License

Abstract

EM2C has developed an emission spectrometer payload (INES) able to perform measurements in the harsh environment of reentry. It will permit to determine quantities of interest such as species concentration and temperatures both from shock layer and the boundary layer where ablation products are present. INES is the first passive, flexible and efficient instrument able to perform such measurement. To promote it to the scientific community, two patents have been registered at the European Patent Office for the INES design on Q1 of 2017.

The poster exposes the work performed in this aspect, the payload is embarked within a Reentry CubeSat named QARMAN (Qubesat for Atmospheric Research and Measurement on Ablation) developed by the von Karman Institute (VKI). It is a flight opportunity representative of LEO returns (low energy reentry: $7.8 \text{ km}\cdot\text{s}^{-1}$ at 120km of altitude). Some missions elements are given in Movie 1 and Figure 1.

Radiation Measurement in the presence of an ablation Product

The reentry phase is a tremendous challenge for engineers as it imposes high surface temperatures on the vehicle (1500-3000K) and large mechanical constrains (8+Gs for Low Earth Orbit return, LEO), all resulting from the different phenomena linked with the transfer of kinetic energy to thermal energy. Radiation is one of the least understood phenomena of reentry and flight data are scarce.

The radiative component of the heat flux is representing 20 to 50% of the total heatflux [BAILET,2014] for the ambitious reentry mission profiles (lunar return, Mars, Venus, Titan, Gas Giants and Ice Giants). An uncertainty of 1% on the flowfield temperature gives about 20% uncertainties on the radiative heat flux. From the importance of the radiative fraction of the heat flux and the associated uncertainty, the need of an efficient radiation measurement payload is needed to ensure minimal design margins and thus optimal payload mass.

In the presence of an ablative/sublimating Thermal Protection System (TPS), gas (phenols, CN, CO...) and dust (charring, soot...) are ejected within the boundary layer and interact with the flow field contributing to the total radiative flux received by the reentry vehicle. The flow field is also carrying along the dust and gases allowing deposits and condensates on different part of the spacecraft.

As illustrated in Figure 2 and 3, traditional approaches are either ineffective (pyrolysis and dust condensates within the optical path) or highly intrusive/complex to integrate.

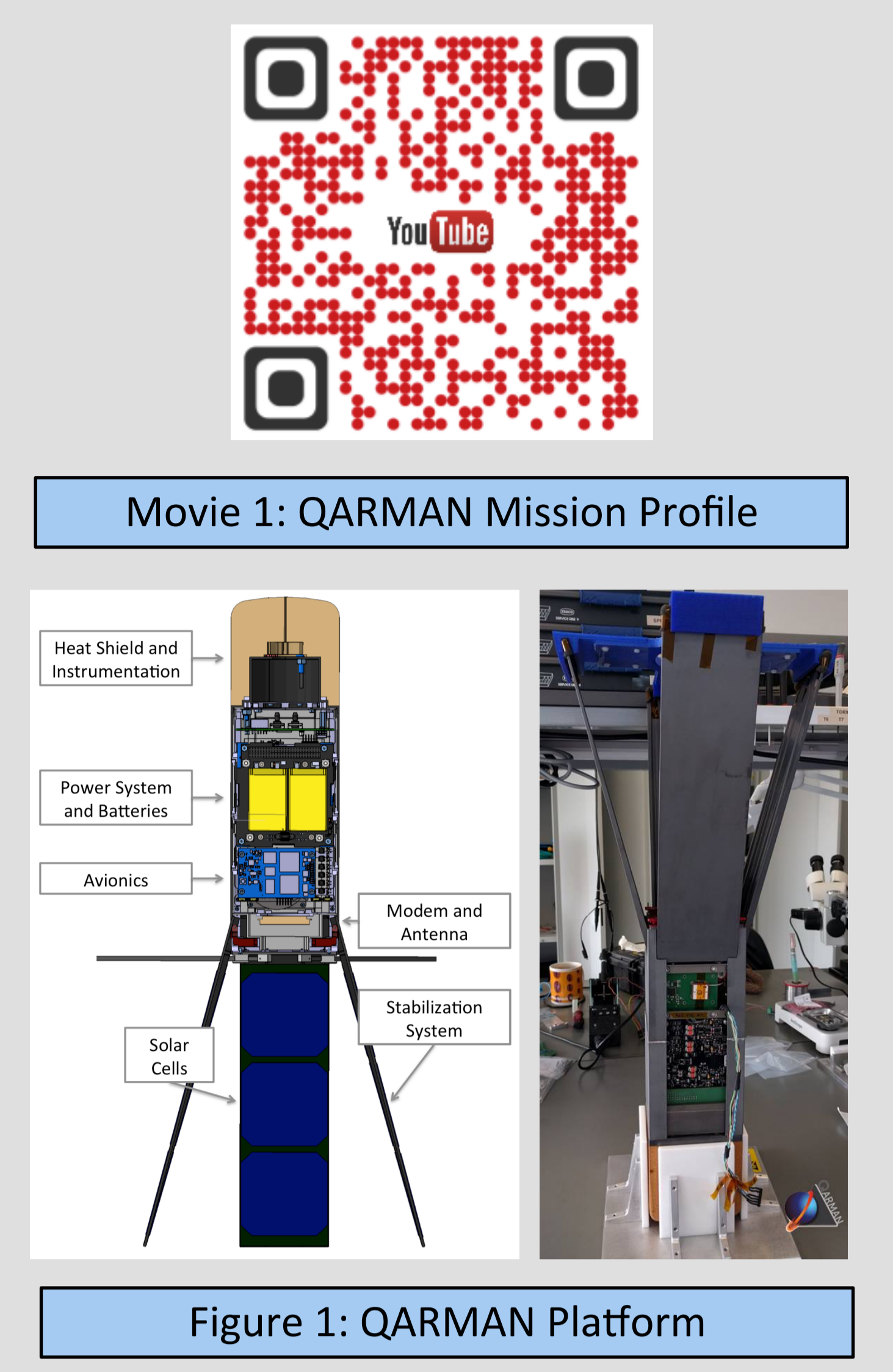

Movie 1: QARMAN Mission Profile

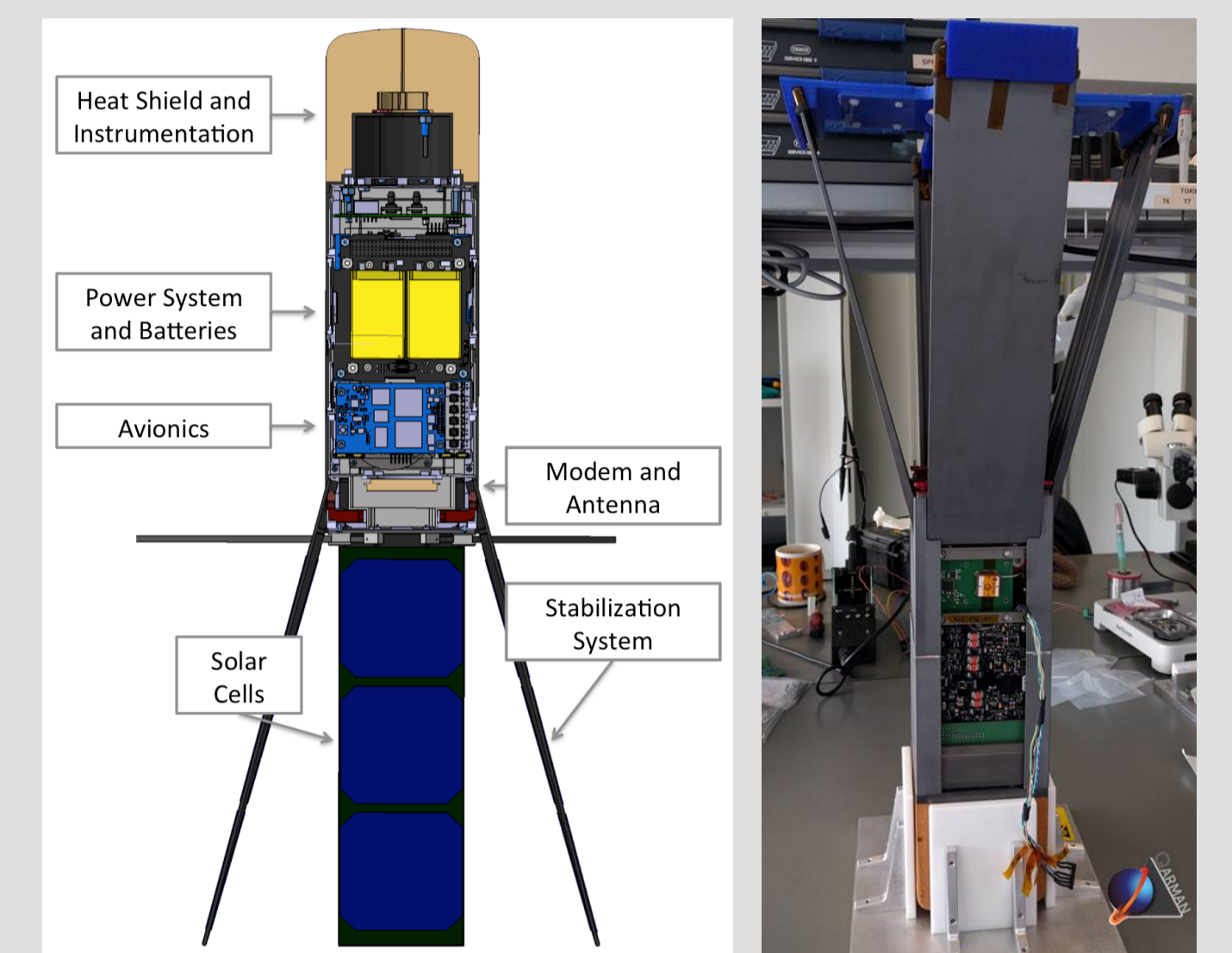

Figure 1: QARMAN Platform

Traditional Approaches (inefficient or Intrusive)

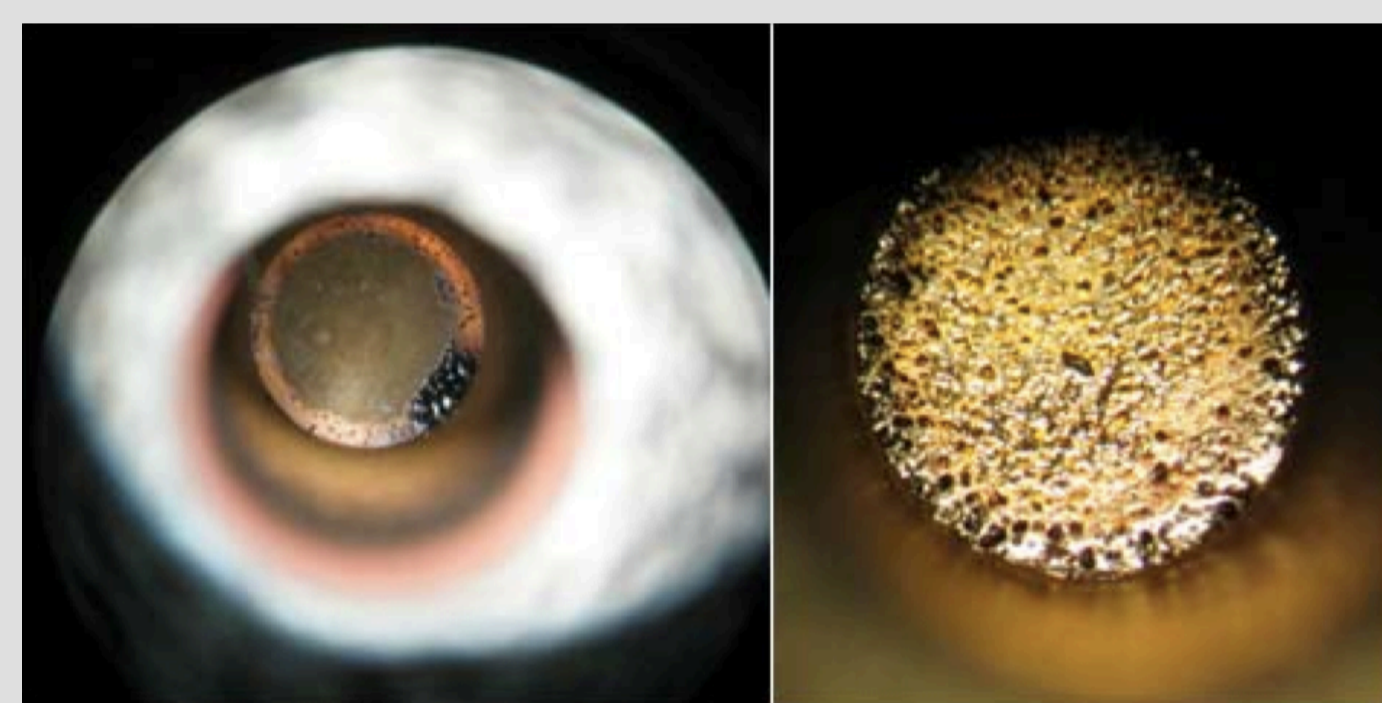

Figure 2: Standard modern passive Approach to perform radiation measurements in the presence of ablative products (Left: before test; Right: after 25s of testing time) [Preci, 2011]

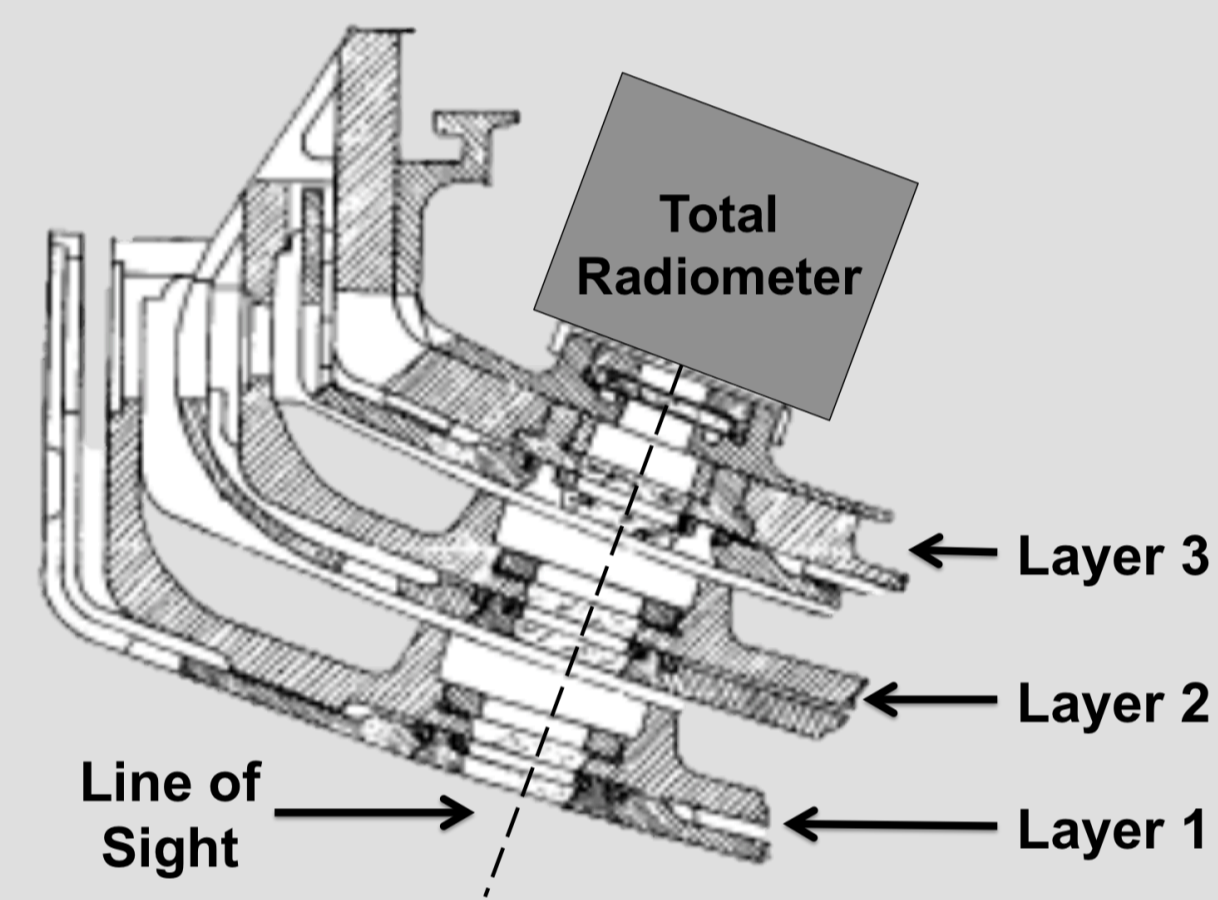

Figure 3: TPS stack for radiation measurement at each layer's ejection (FIRE program) [Cauchon, 1967]

INES Payload (Efficient, Non-intrusive and Highly Flexible)

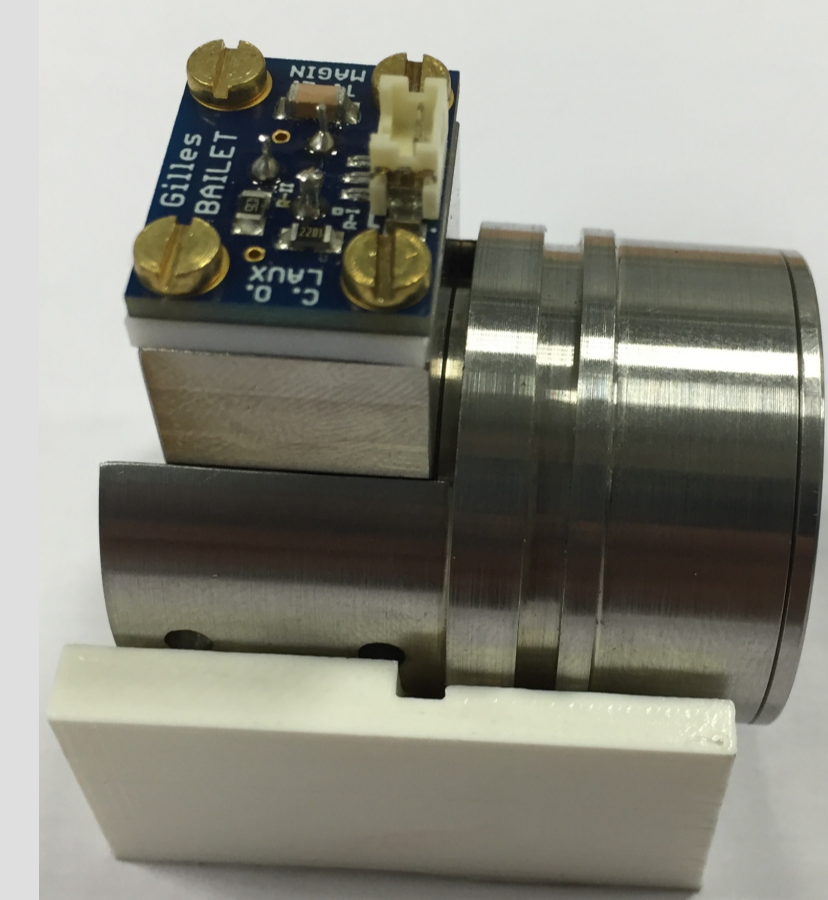

Figure 4: Total radiative flux configuration 150 g (Radiation + Recession/Swelling)

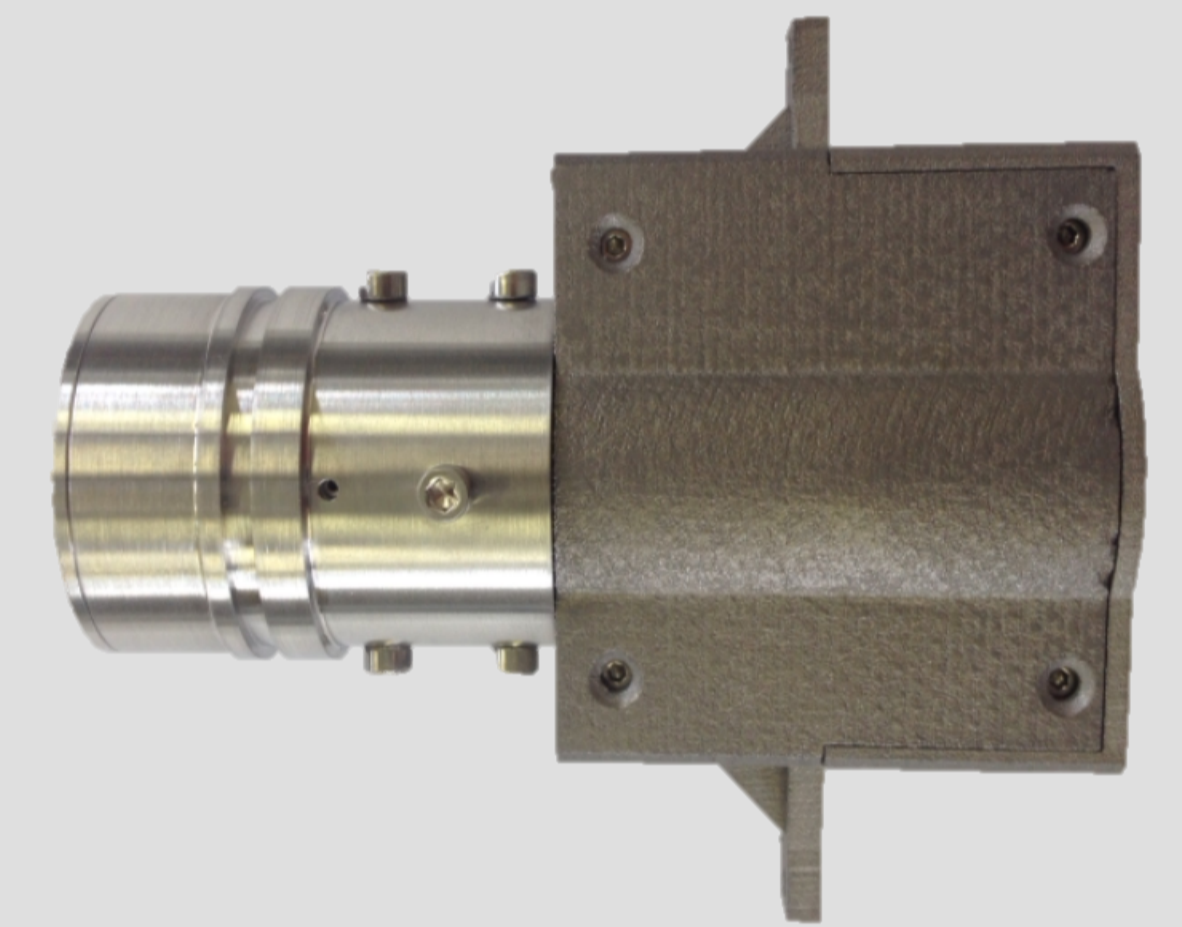

Figure 5: Emission spectrometer configuration 350 g (Radiation + Recession/Swelling)

A Flexible and High-Performance Payload for all Reentry Missions

Several test campaigns have been organized at EM2C and VKI ground test facilities (high enthalpy inductively coupling plasma torches) allowing for successful testing of INES on a wide range of reentry conditions: sub-orbital reentry with sublimated PTFE TPS material (Figure 6), lunar return type reentry (Figure 7), Mars type entry with a CO_2 test gas (Figure 8) and ISS return type reentry (Figure 9).

For the whole range of testing, the INES payload effectively measured radiation without being impacted by the pollution of the tested ablative/sublimating TPS (Cork P50, PTFE, ASTERM, Graphite). The duration of the tests (plasma exposure) were limited only by the TPS sample thickness and the rate of ablation/sublimation. The test conditions were chosen as the peak heat flux conditions of each associated reentry mission profile. In this aspect, the total heat load of each test was between one and two order of magnitude superior to the one of the associated reentry mission profile.

An example of the total radiative flux measured during the test dedicated to the ISS return type reentry conditions ($Q_{\text{dot}} = 3 \text{ MW}/\text{m}^2$, $P_{\text{stat}} = 100 \text{ mbar}$, $Q = 900 \text{ MJ}/\text{m}^2$ and Cork P50 ablative material) is shown in Figure 9. As observed, the measured radiation intensity is stable over a period of 5 minutes corresponding to the total recession of a 3 cm thick Cork P50 sample without any .

The different qualification tests have shown INES as a high performance payload suited for a wide range of missions from low earth orbit return to Mars entry and Lunar return. To go further, a new facility has to be used to cover the mission profiles of interest such as Gas and Ice Giants.

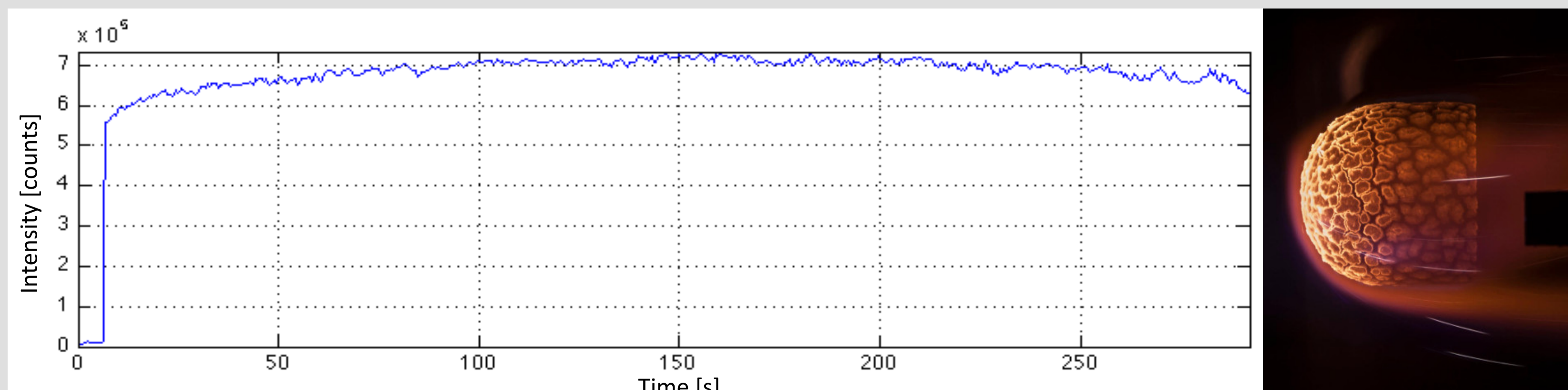

Figure 9: Radiative flux during the INES Qualification test where no effect of ablation products is observed (Test gas: Air; $Q_{\text{dot}} = 3 \text{ MW}/\text{m}^2$; $P_{\text{stat}} = 100 \text{ mbar}$; Cork P50 ablative material)

Figure 6:

Low ballistic coefficient test conditions

- Test gas: Air
- $Q_{\text{dot}} = 300 \text{ kW}/\text{m}^2$
- $P_{\text{stat}} = 40 \text{ mbar}$

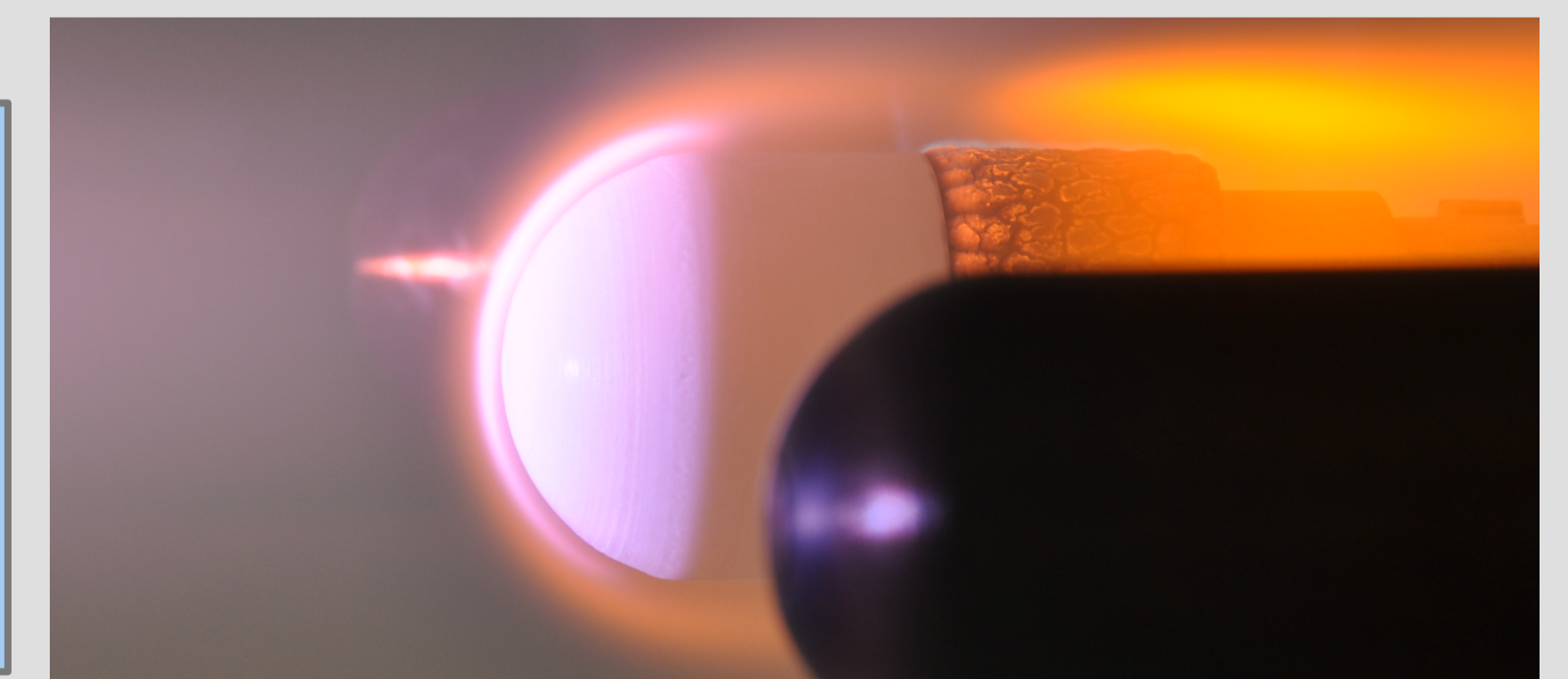

Figure 7:

High Energy Reentry test conditions

- Test gas: Air
- $Q_{\text{dot}} = 8-10 \text{ MW}/\text{m}^2$
- $P_{\text{stat}} \approx 800 \text{ mbar}$

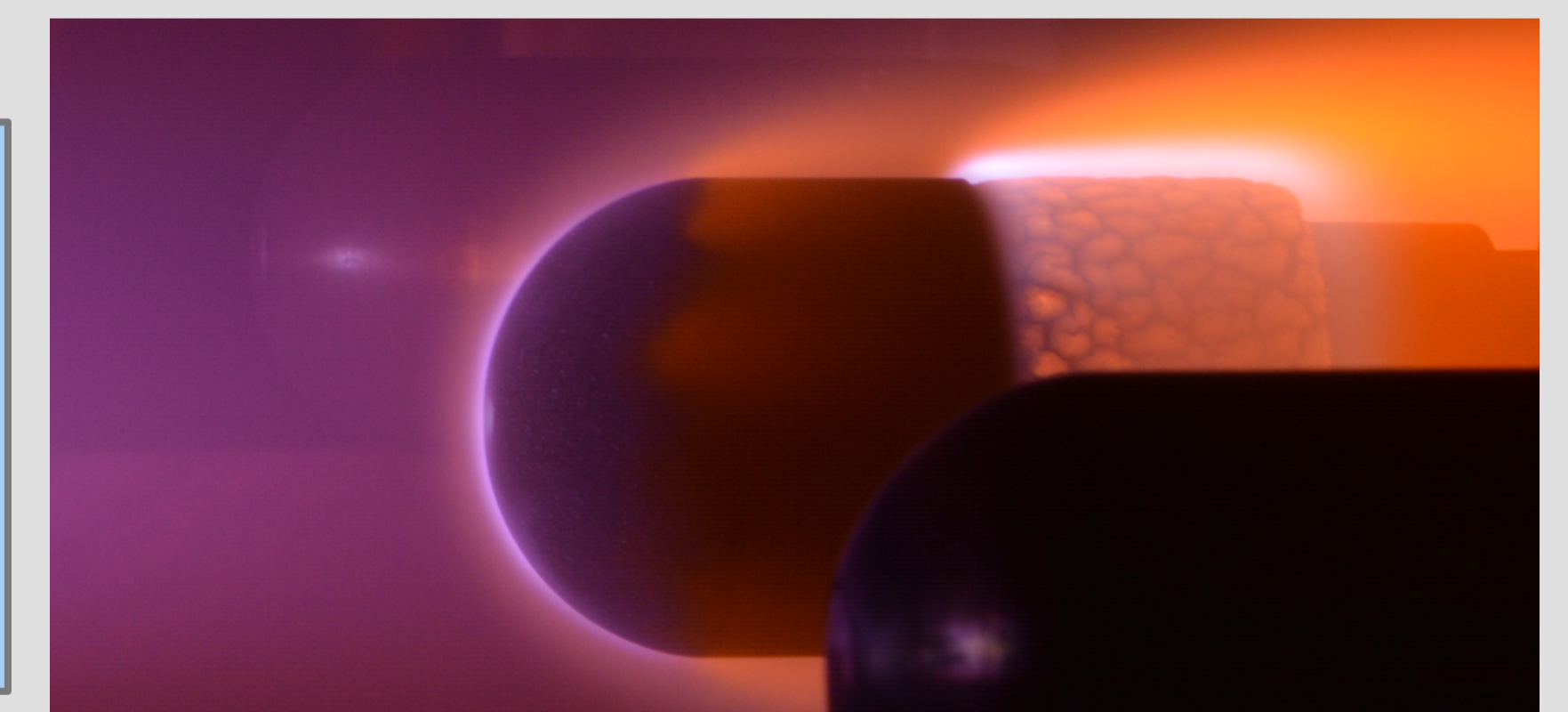
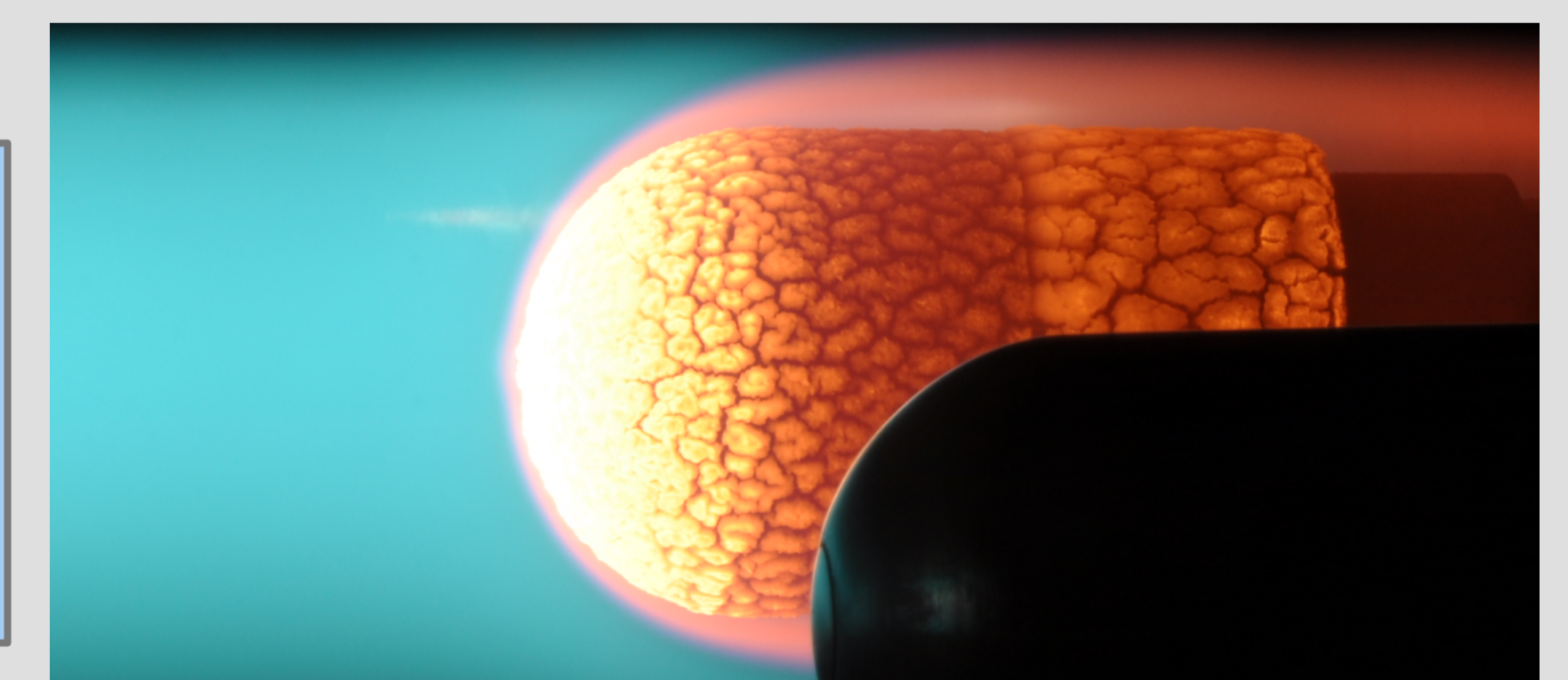

Figure 8:

Mars Entry test conditions

- Test gas: CO_2
- $Q_{\text{dot}} = 2,6 \text{ MW}/\text{m}^2$
- $P_{\text{stat}} = 100 \text{ mbar}$



References

- [BAILET,2014] G. Bailet, et Al. (2014), Re-Entry Platform for Radiation Studies. 6th International Workshop on Radiation of High Temperature Gases in Atmospheric Entry, St Andrews, UK.
- [Preci, 2011] Preci, et Al. (2011), Development of a Combined Sensor System for Atmospheric Entry Missions, 7th European Symposium on Aerothermodynamics for Space Vehicles.
- [Cauchon, 1967] Cauchon, D.L, Radiative Heating Results from the FIRE II Flight Experiment at a Re-entry Velocity of 11.4 Kilometers per Second, TM X-1402, NASA, 1967.

Acknowledgments

The research leading to these results has received funding and support from AIRBUS Safran Launchers through the ANRT's CIFRE program. The authors would like to thank the other QARMAN Team members, as well as Sean Mc Guire, David Charalampous, Jean-Marc Bouilly, Franck Delattre, Coumar Oudea, Pascal Collin and the IPPW committee for accepting this poster and providing th student fellowship.