



**HAL**  
open science

## Structural & Spectroscopic Study of InAs/InP Quantum Dots for Dual-Frequency Laser Engineering

Gaëlle Brévalle, Mathieu Perrin, Cyril Paranthoen, Christophe Levallois, Yoan Léger, Hervé Folliot, Mehdi Alouini

► **To cite this version:**

Gaëlle Brévalle, Mathieu Perrin, Cyril Paranthoen, Christophe Levallois, Yoan Léger, et al.. Structural & Spectroscopic Study of InAs/InP Quantum Dots for Dual-Frequency Laser Engineering. 16<sup>e</sup> Journées Nano, Micro et Optoélectronique (JNMO 2018), Jun 2018, Agay, France. hal-01859165

**HAL Id: hal-01859165**

**<https://hal.science/hal-01859165v1>**

Submitted on 17 Oct 2018

**HAL** is a multi-disciplinary open access archive for the deposit and dissemination of scientific research documents, whether they are published or not. The documents may come from teaching and research institutions in France or abroad, or from public or private research centers.

L'archive ouverte pluridisciplinaire **HAL**, est destinée au dépôt et à la diffusion de documents scientifiques de niveau recherche, publiés ou non, émanant des établissements d'enseignement et de recherche français ou étrangers, des laboratoires publics ou privés.

# Structural & Spectroscopic Study of InAs/InP Quantum Dots for Dual-Frequency Laser Engineering

G. Brévalle<sup>1</sup>, M. Perrin<sup>1</sup>, C. Paranthoën<sup>1</sup>, C. Levallois<sup>1</sup>, Y. Léger<sup>1</sup>, H. Folliot<sup>1</sup>, M. Alouini<sup>1</sup>  
<sup>1</sup>Univ Rennes, INSA Rennes, CNRS, Institut FOTON – UMR 6082, F-35000 Rennes, France  
 gaelle.brevalle@insa-rennes.fr

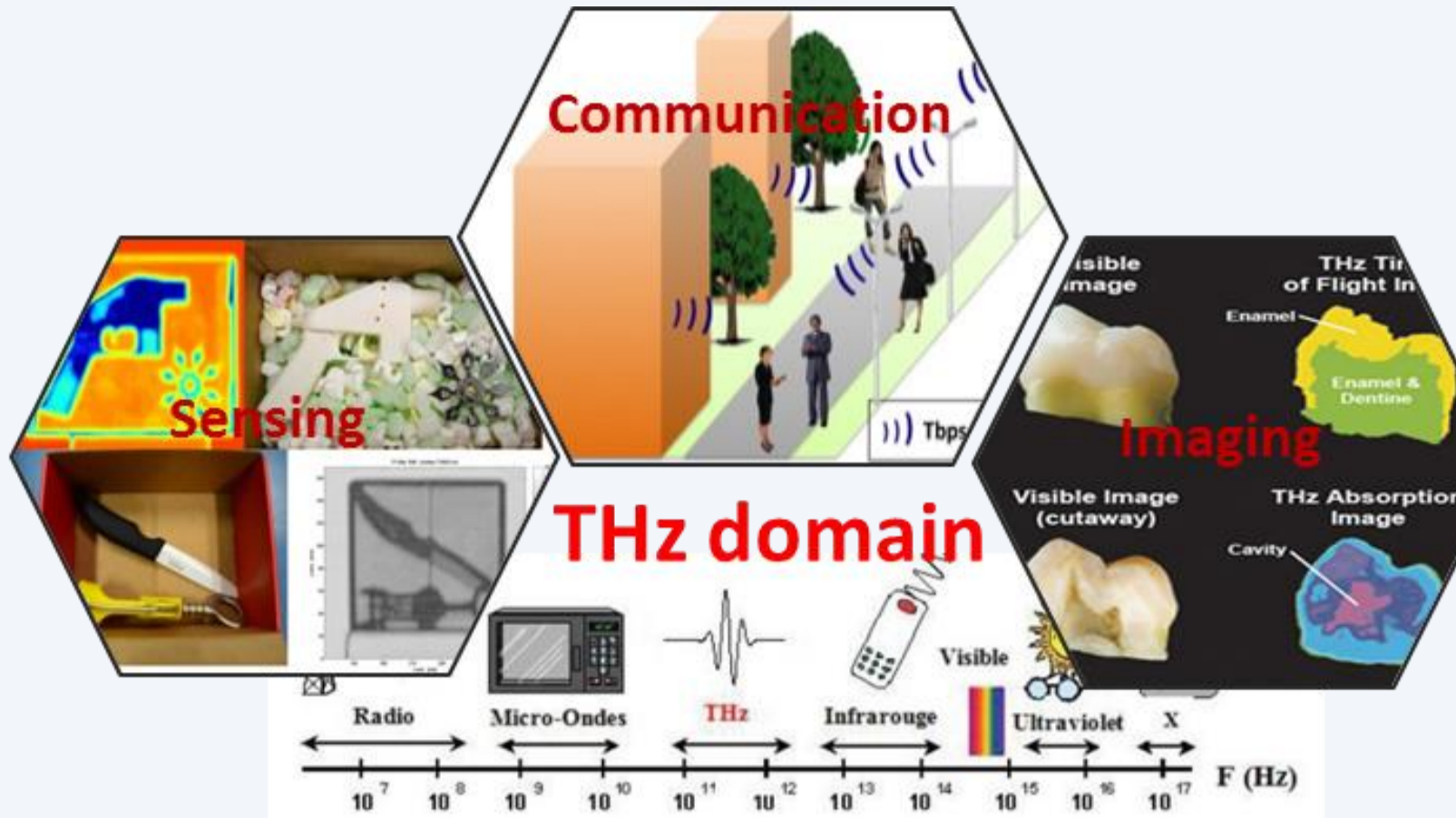

**THz domain**

Why VECSEL ?

- Low intensity and phase noise
- Dual-wavelength regime possible

Why QDs ?

- Weak coupling (inhomogeneous medium)
- Possible electrical injection

### Introduction

**Problem**  
Few efficient compact tunable room temperature THz sources available

Wavelength beating from a Coherent dual wavelength Quantum Dots (QDs) based Vertical External Cavity Surface Emitting Laser (VECSEL)

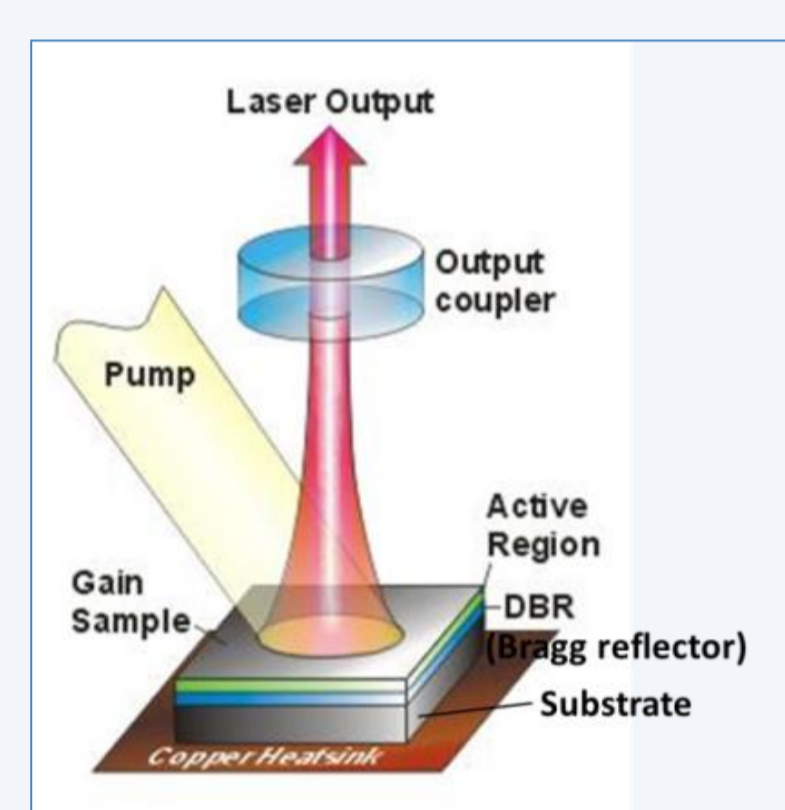

### Requirements for the QDs

InAs/InP QDs  
Molecular Beam Epitaxy Growth parameters:

- AsH<sub>3</sub> Flow
- Quantity of deposited InAs

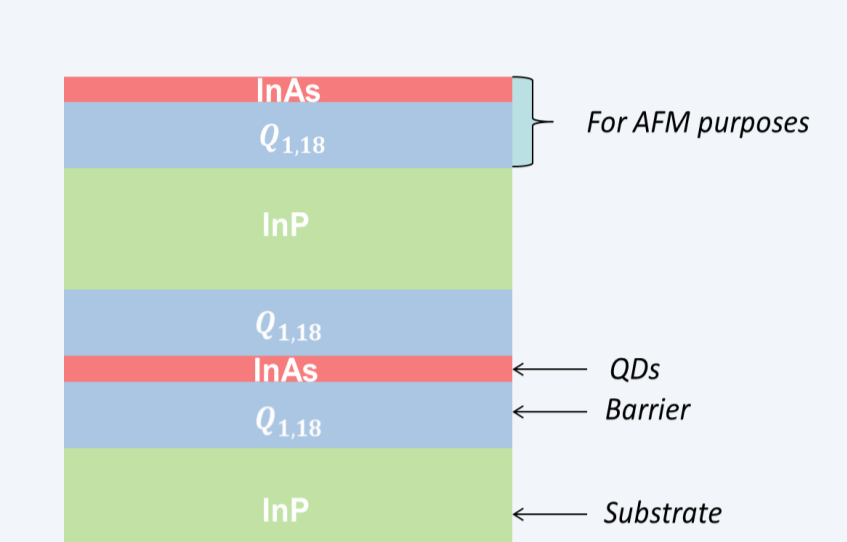

**Telecom wavelength**

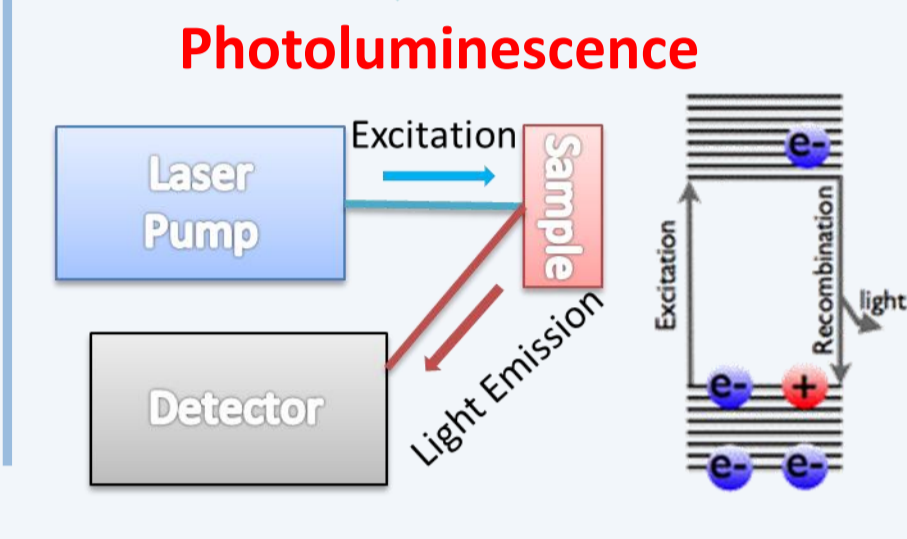

Photoluminescence

**Weak Coupling**

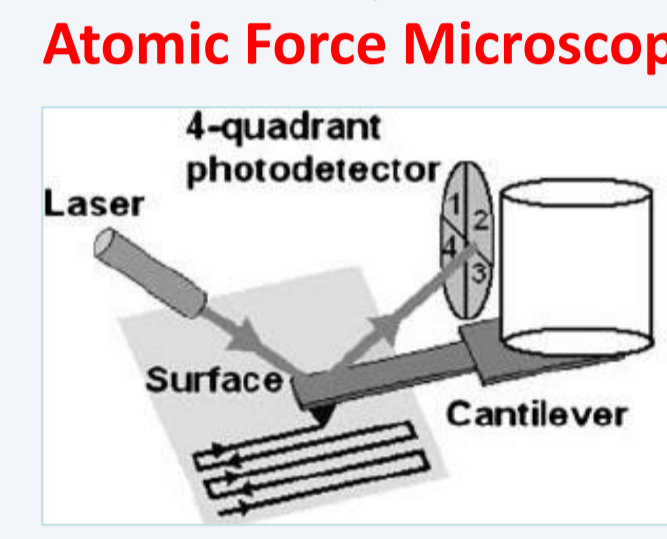

Atomic Force Microscopy

**Homogeneous linewidth**

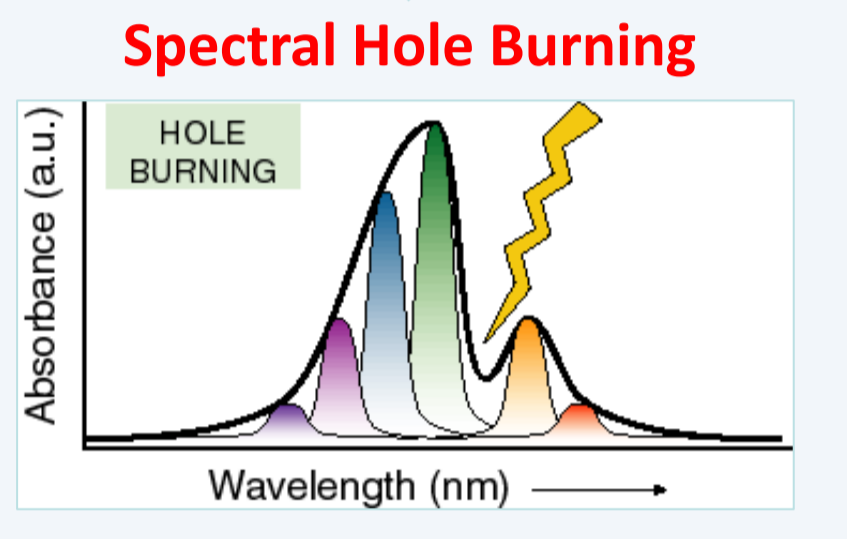

Spectral Hole Burning

### Tuning of the QDs density - AFM

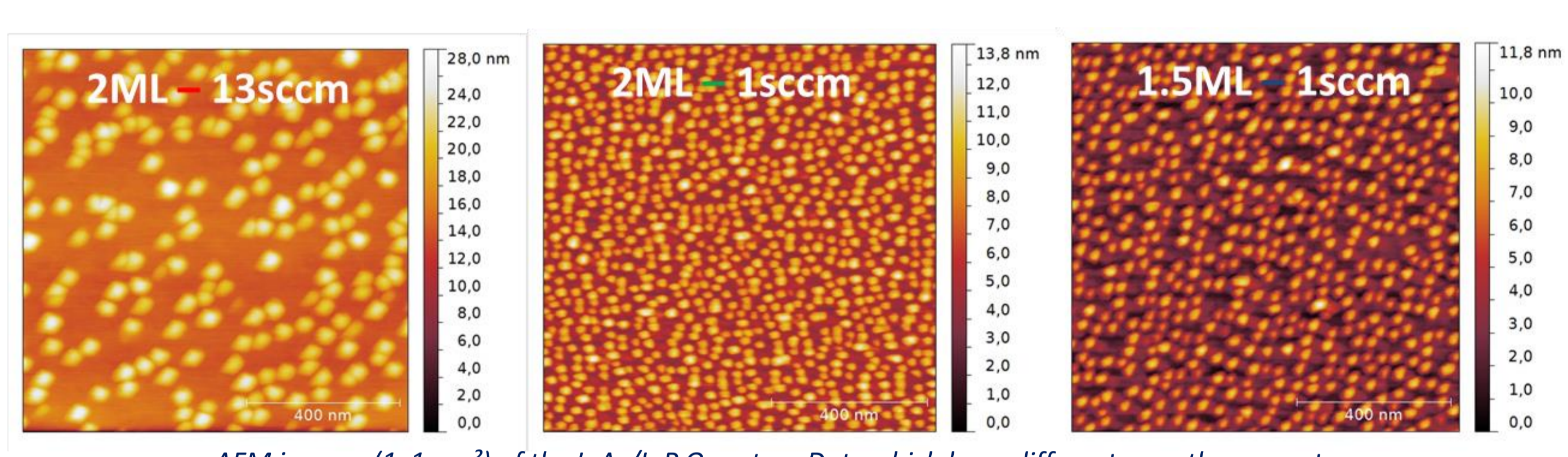

AFM images (1x1 μm<sup>2</sup>) of the InAs/InP Quantum Dots which have different growth parameters

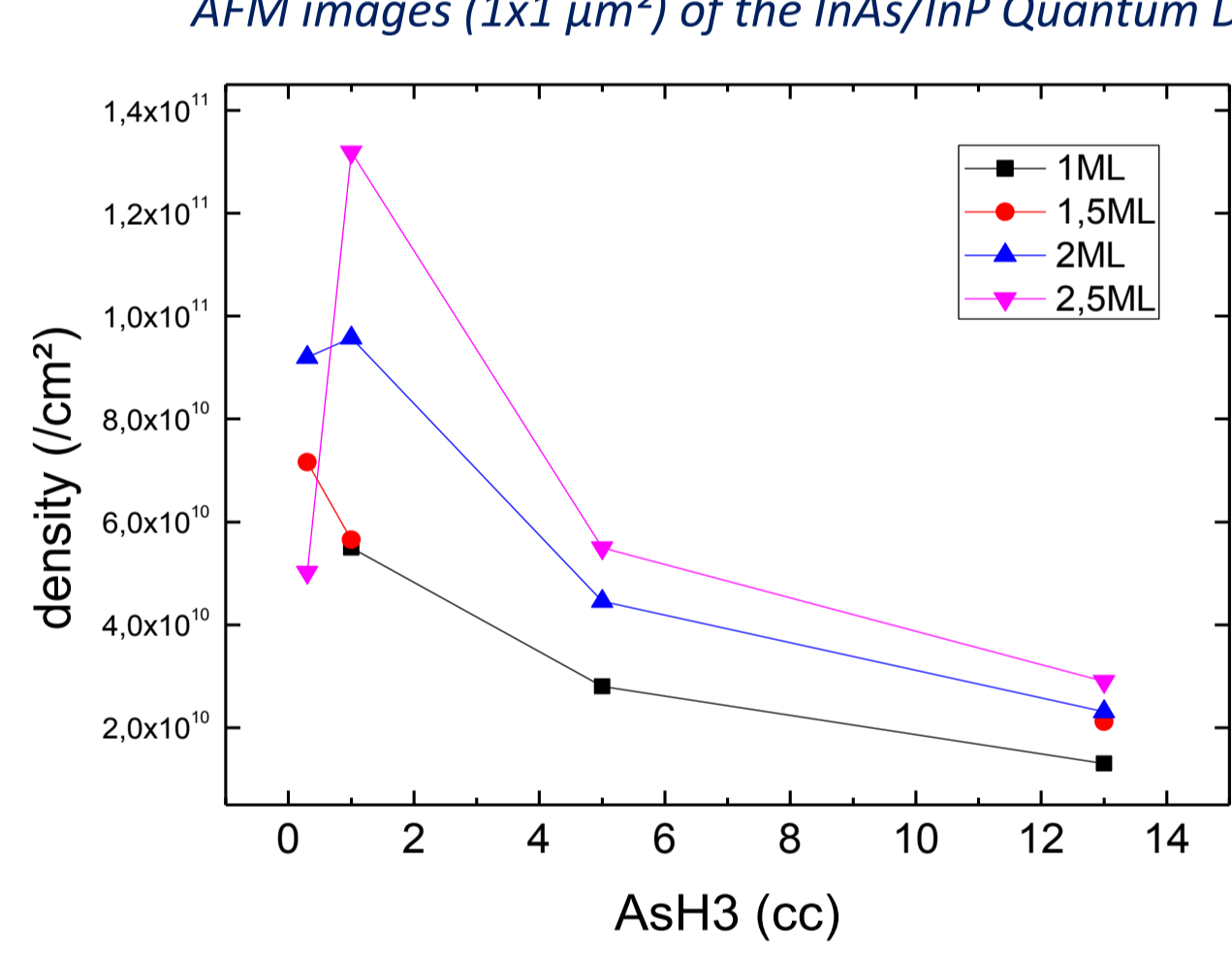

QDs density as a function of AsH<sub>3</sub> Flow

When the AsH<sub>3</sub> Flow increases, the QDs get bigger and the density greatly decreases (x10)

### QDs size and emission wavelength

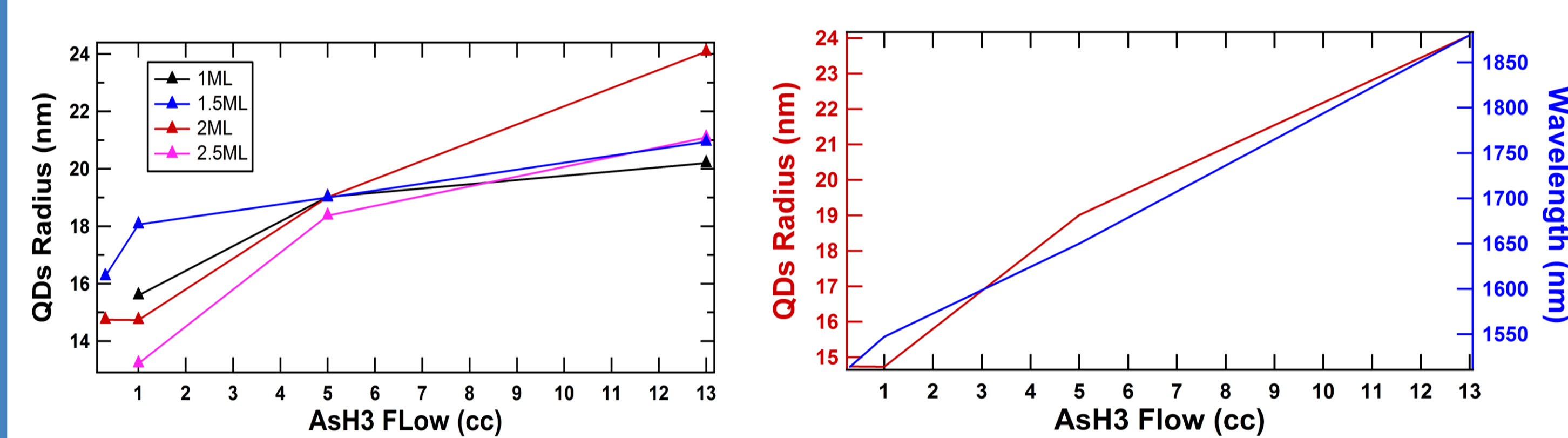

The radius of the QDs is bigger for higher flow

For 2ML: QDs radius and wavelength as a function of As Flow  
Bigger QDs → Higher emission wavelength

QDs = self-assembled nanostructure → impossible to control the size and consequently the wavelength

### Control of the wavelength – Double Cap

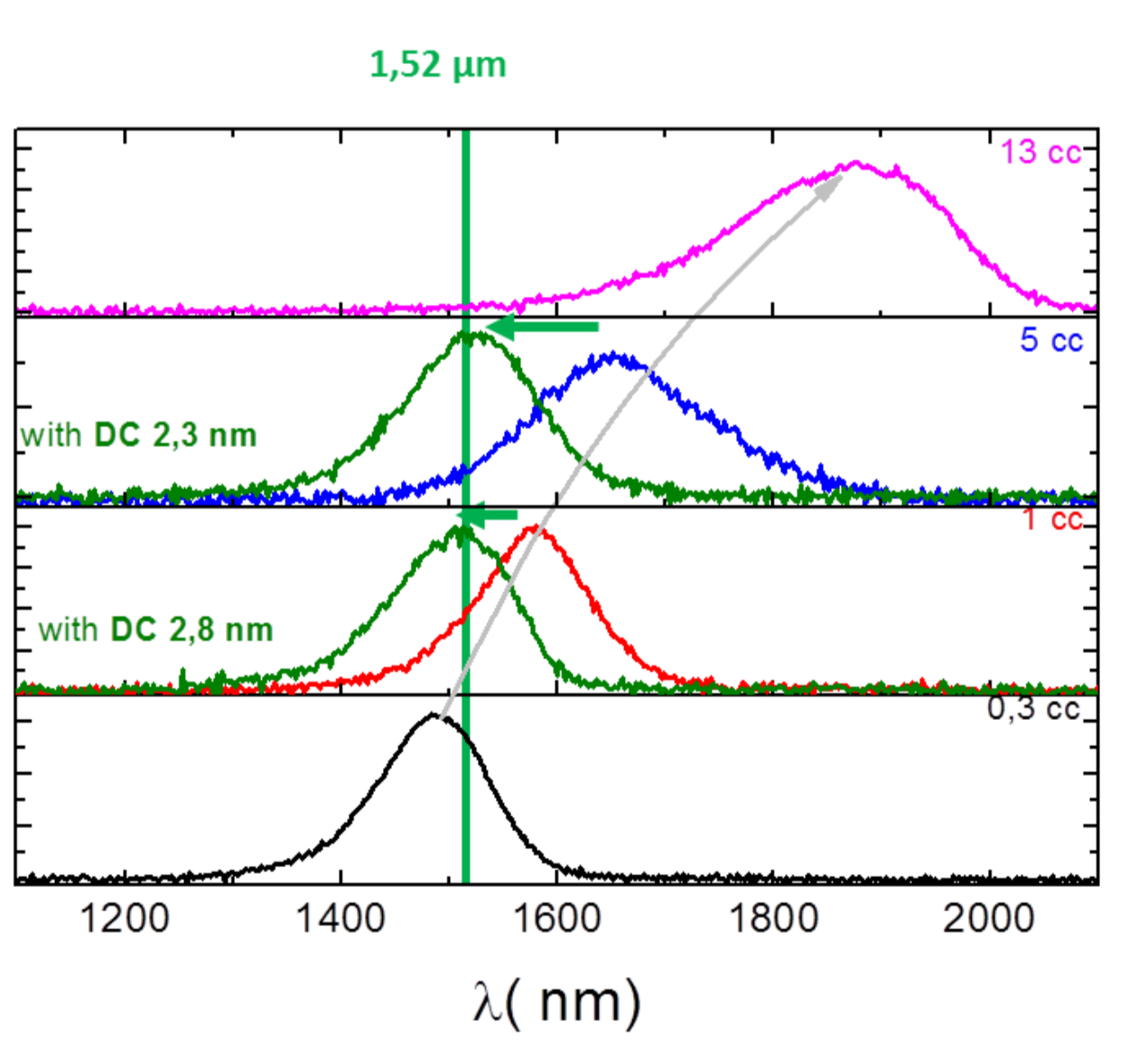

Emission Wavelength for different AsH<sub>3</sub> flow

QDs Wavelength: Tendency with growth parameters but impossibility to control it by only the growth

**Double cap process**

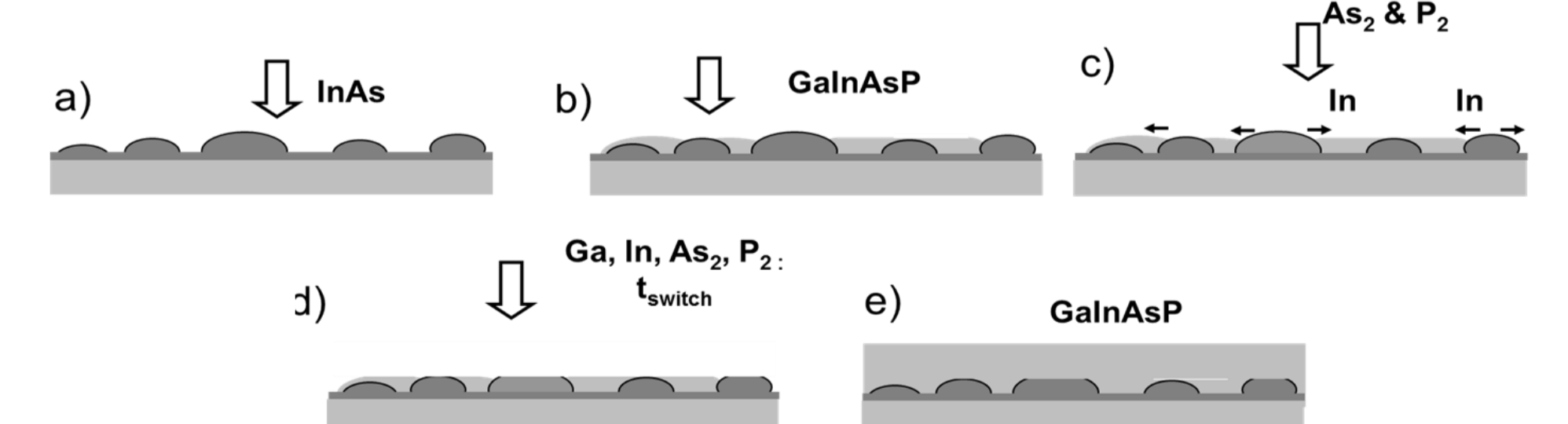

Schematic of the Double cap process

### Spectral Hole Burning Experimental Setup

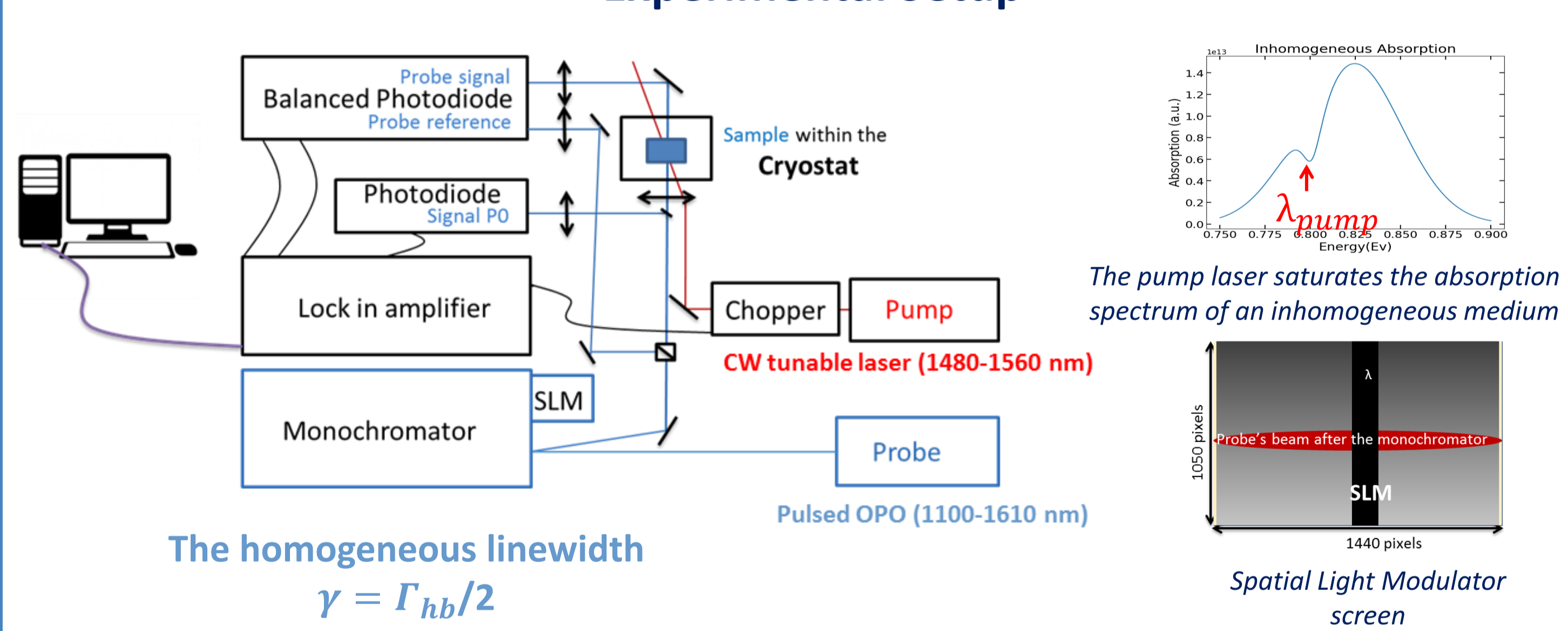

The homogeneous linewidth  $\gamma = \Gamma_{hb}/2$

### Preliminary Results (on QWs)

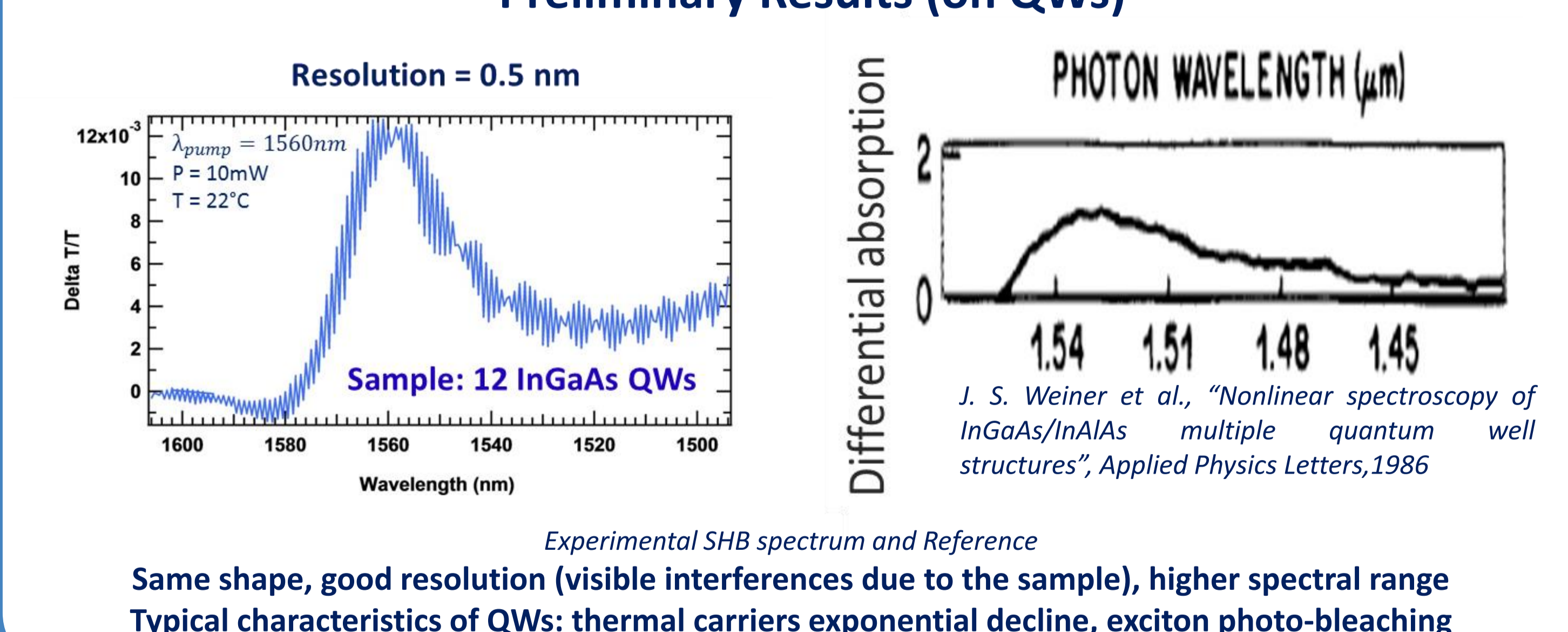

Resolution = 0.5 nm

Sample: 12 InGaAs QWs

Experimental SHB spectrum and Reference

Same shape, good resolution (visible interferences due to the sample), higher spectral range

Typical characteristics of QWs: thermal carriers exponential decline, exciton photo-bleaching

### Conclusion

- QDs density (and coupling) mainly controlled by the As flow: changed from 10<sup>11</sup> down to 10<sup>10</sup> cm<sup>-2</sup>, with a strong effect on the wavelength emission: from 1500 nm to 1945 nm
- Independent control of the density and wavelength (double cap)
- SHB experimental setup ready with good resolution (<0.5nm) and high spectral range (500 nm)
- Results on QWs correspond well with the bibliography

### Perspectives

- Achievement of SHB in order to get the homogeneous linewidth broadening as a function of QDs density, temperature, input power
- Optimisation of QDs density to get the weaker coupling
- VECSEL characterisation